

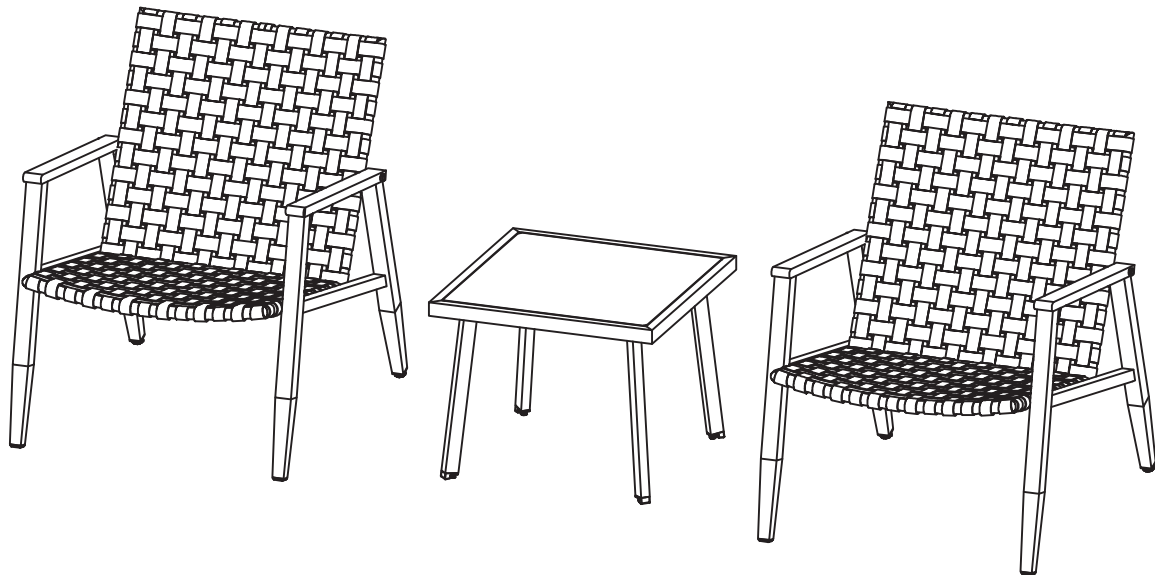

Wicker Seating Set
Assembly & Care instructions
Model number: RS24067-B3











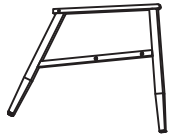

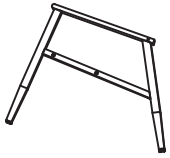

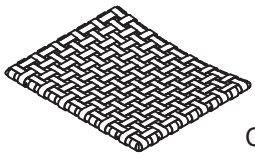
Warning

1. Pls confirm all parts correct before assemble.
2. Do not tighten fastening fully until assembly is completed.
3. **DO NOT USE POWER TOOLS.** Power tools can overtighten screws and strip threads.
4. Please read & retain this manual for future reference .
5. Maximum Load: Chair 350lbs & Table 110lbs.

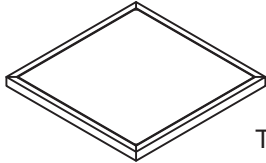
If you have any questions, feel free to contact us info@comlax-intl.com

PARTS LIST

CODE	PARTS	QTY.	CODE	PARTS	QTY.
A	 Armrest-L	2pcs	G	 M6x15	12pcs
B	 Armrest-R	2pcs	H	 M6x40	12pcs
C	 Chair back	2pcs	I	 M6x55	4pcs
D	 Chair seat	2pcs	J	 Washer Ø6*14	28pcs
E	 Table top	1pcs	K	 Allen Key	1pcs
F	 Table leg	4pcs	L	 Bolt Cap (M6)	28pcs

ATTENTION: Do not fully tighten until assembly is complete!

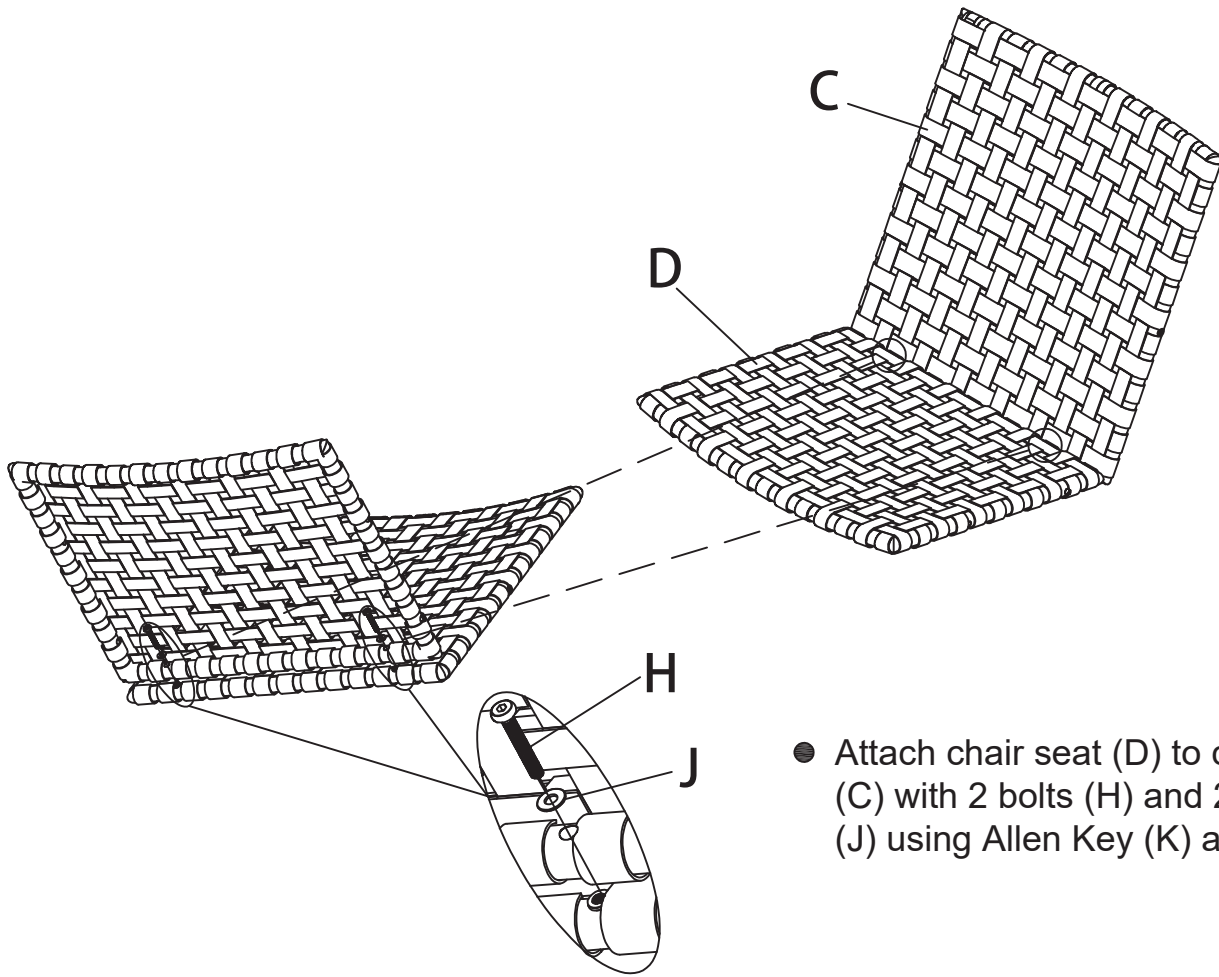

- Attach chair seat (D) to chair back (C) with 2 bolts (H) and 2 washers (J) using Allen Key (K) as shown.

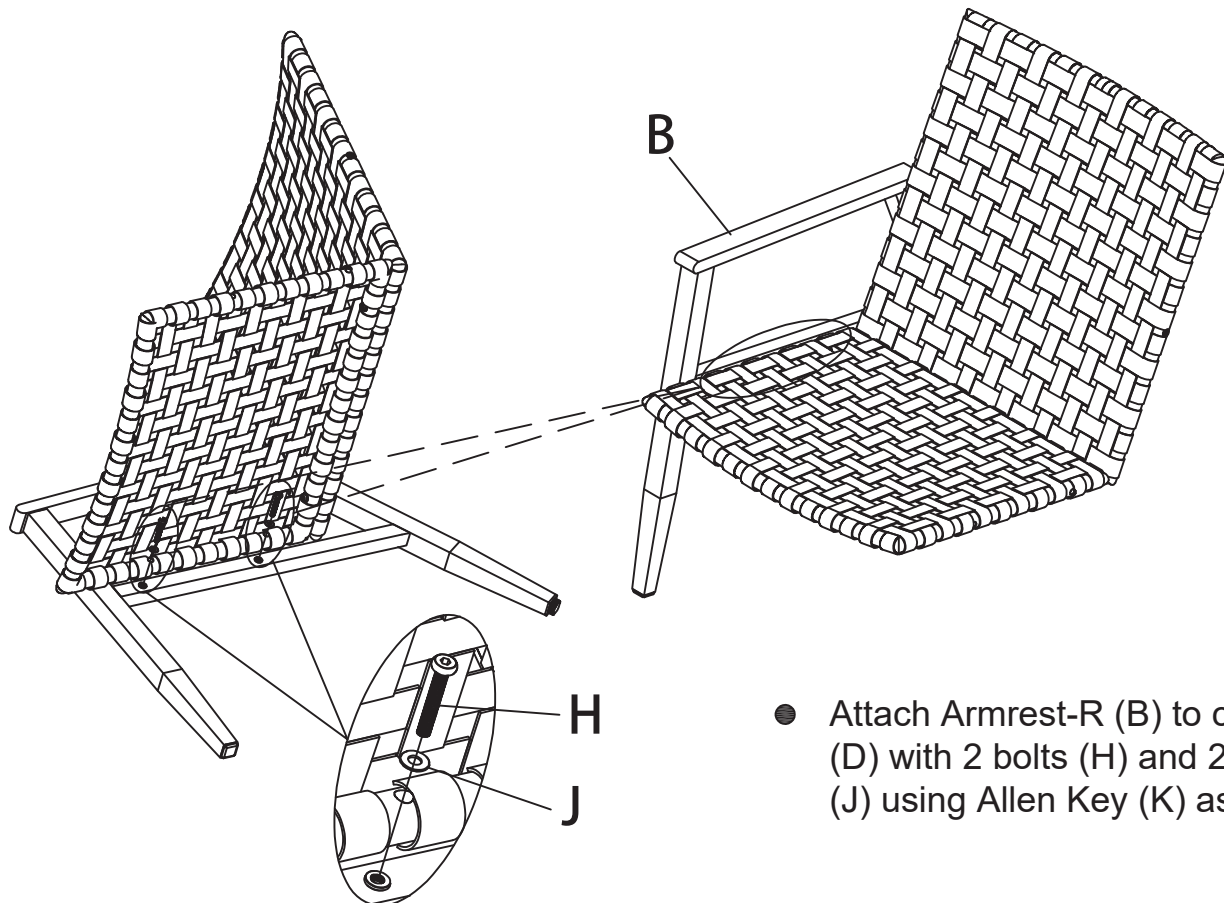

- Attach Armrest-R (B) to chair seat (D) with 2 bolts (H) and 2 washers (J) using Allen Key (K) as shown.

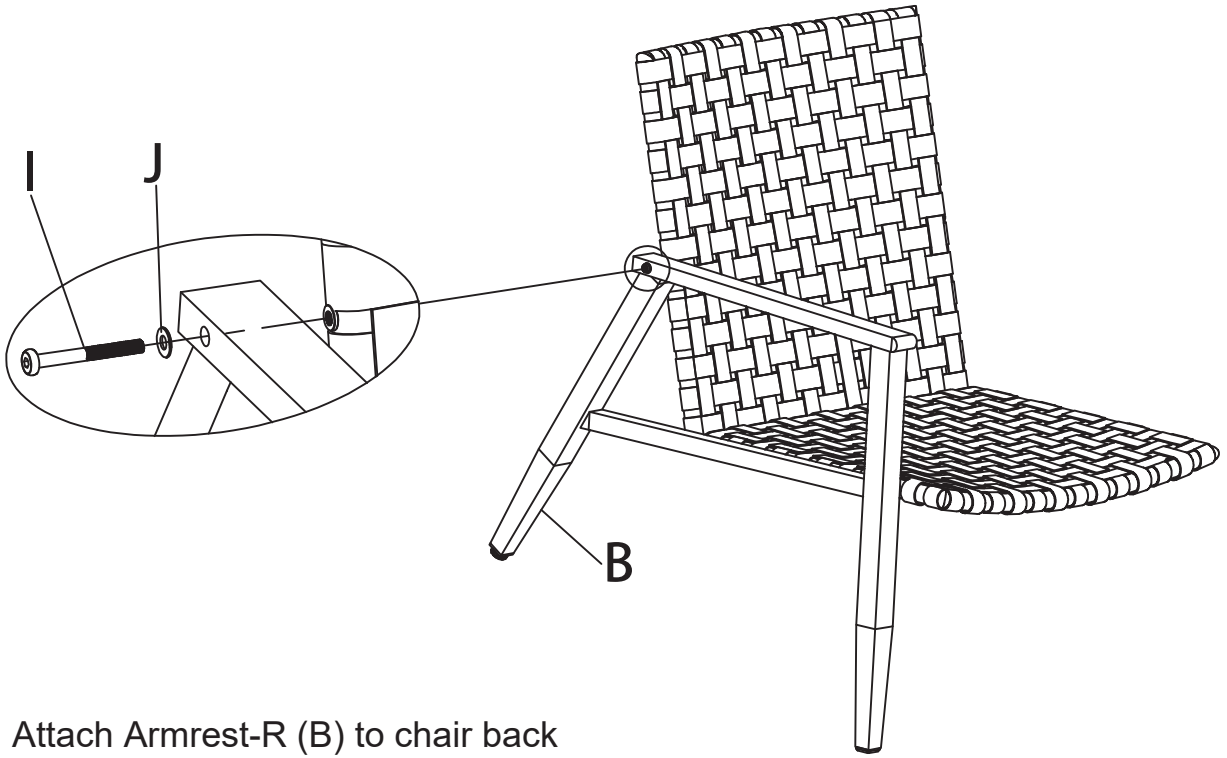

- Attach Armrest-R (B) to chair back (C) with 1 bolts (I) and 1 washers (J) using Allen Key (K) as shown.

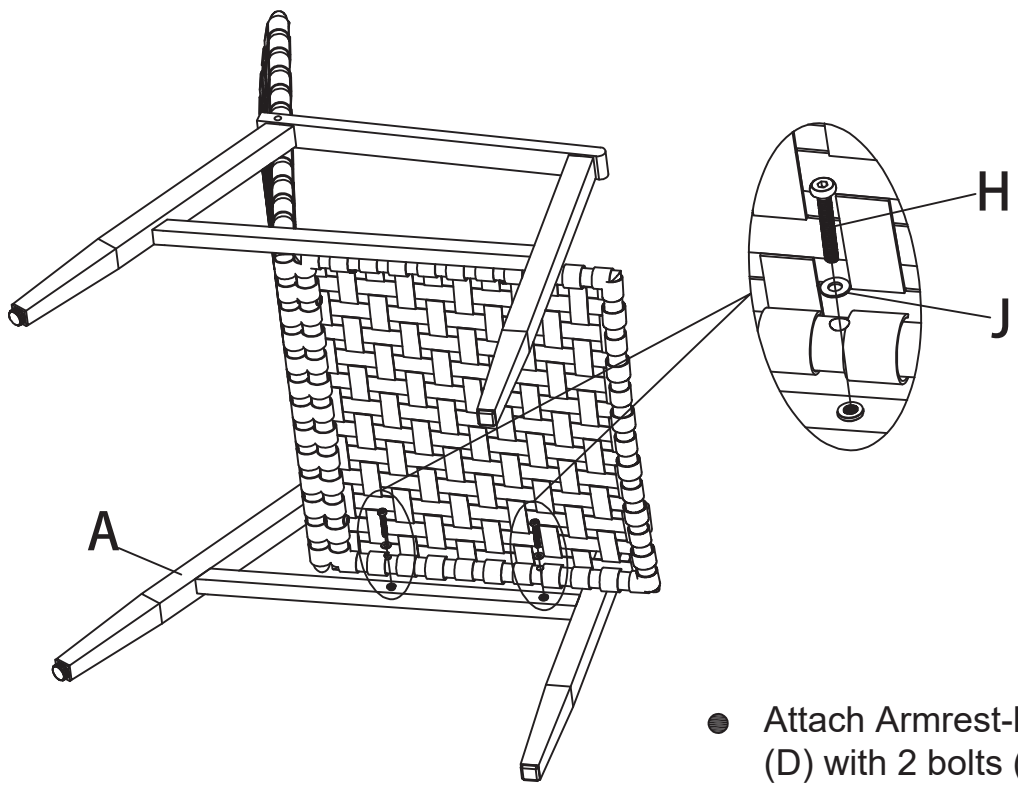

- Attach Armrest-L (A) to chair seat (D) with 2 bolts (H) and 2 washers (J) using Allen Key (K) as shown.

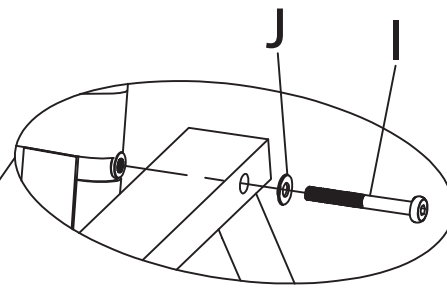
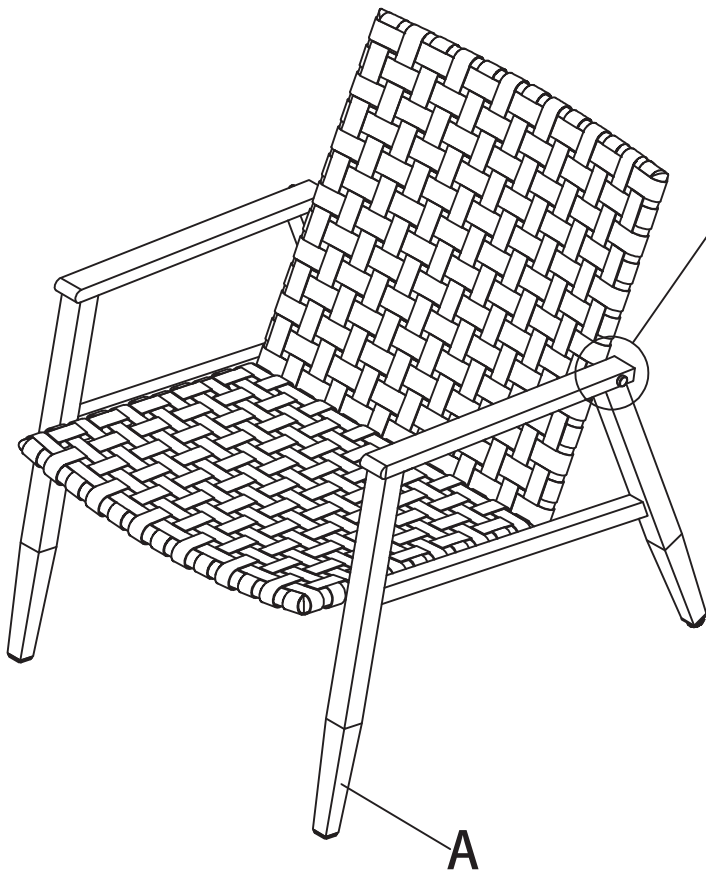

- Attach Armrest-L (A) to chair back (C) with 1 bolts (I) and 1 washers (J) using Allen Key (K) as shown.

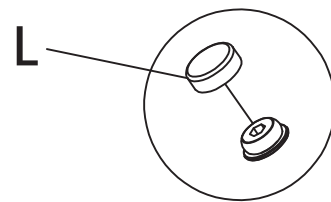
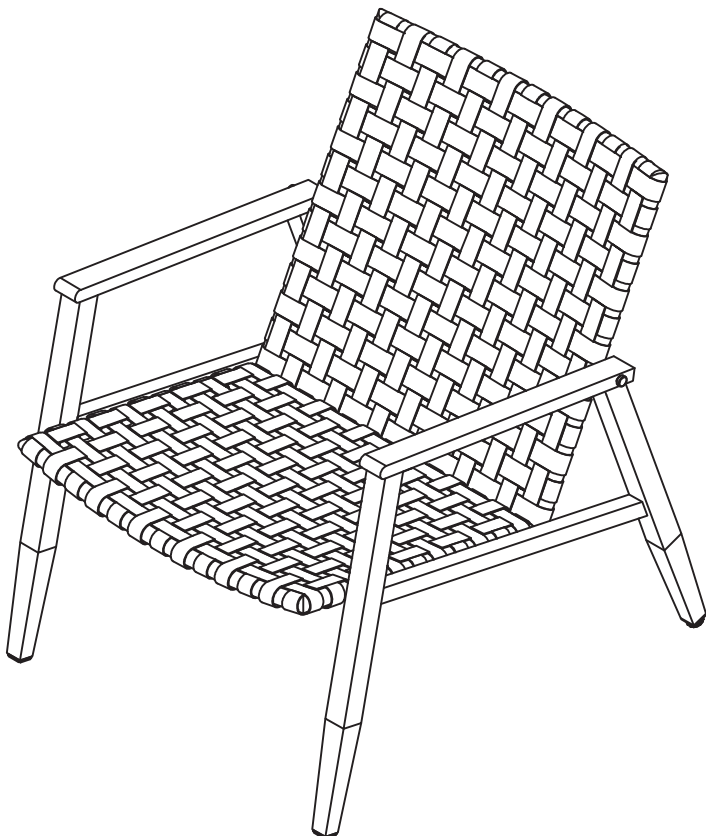

- Once all bolts have been inserted and started, then tighten all bolts and put on all bolt caps (L).
- Level the chair with adjustable feet cap if necessary as shown.

ATTENTION: Do not fully tighten until assembly is complete!

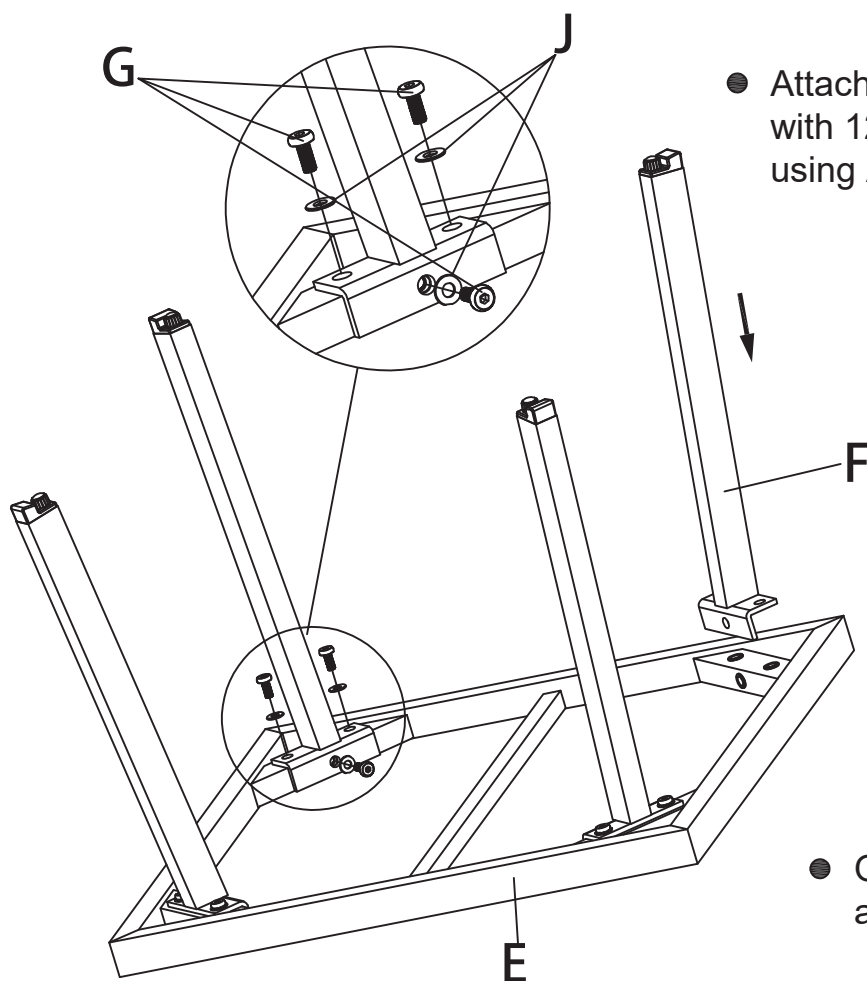

- Attach 4 Table legs (F) to Table Top (E) with 12 bolts (G) and 12 washers (J) using Allen Key (G) as shown.

- Once all bolts have been inserted and started, then tighten all bolts.

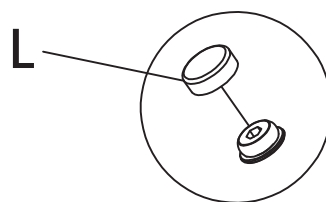
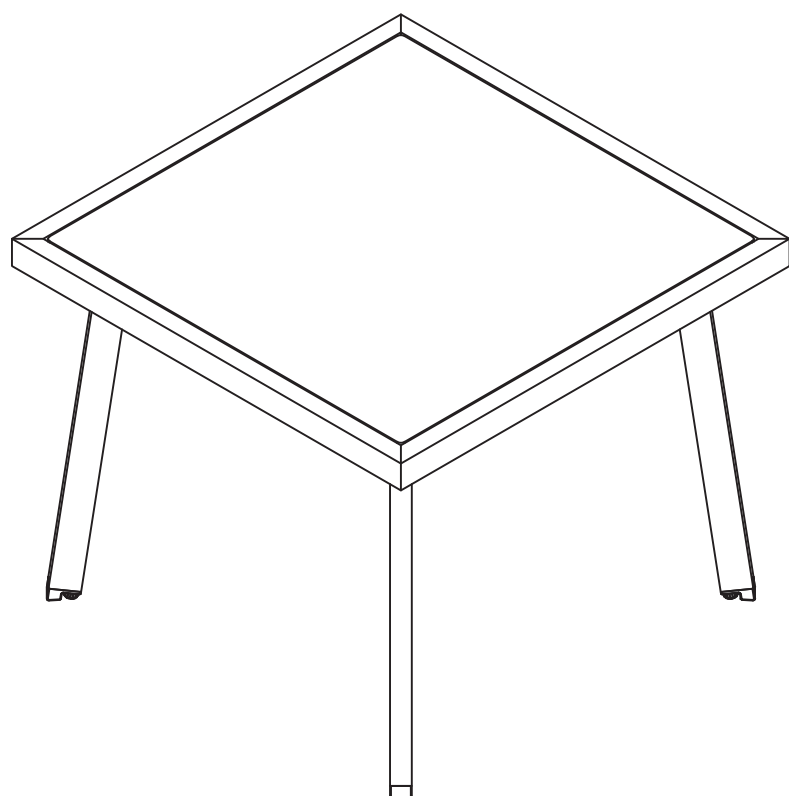

- Once all bolts have been inserted and started, then tighten all bolts and put on all bolt caps (L).

- Level the table with adjustable feet cap if necessary.

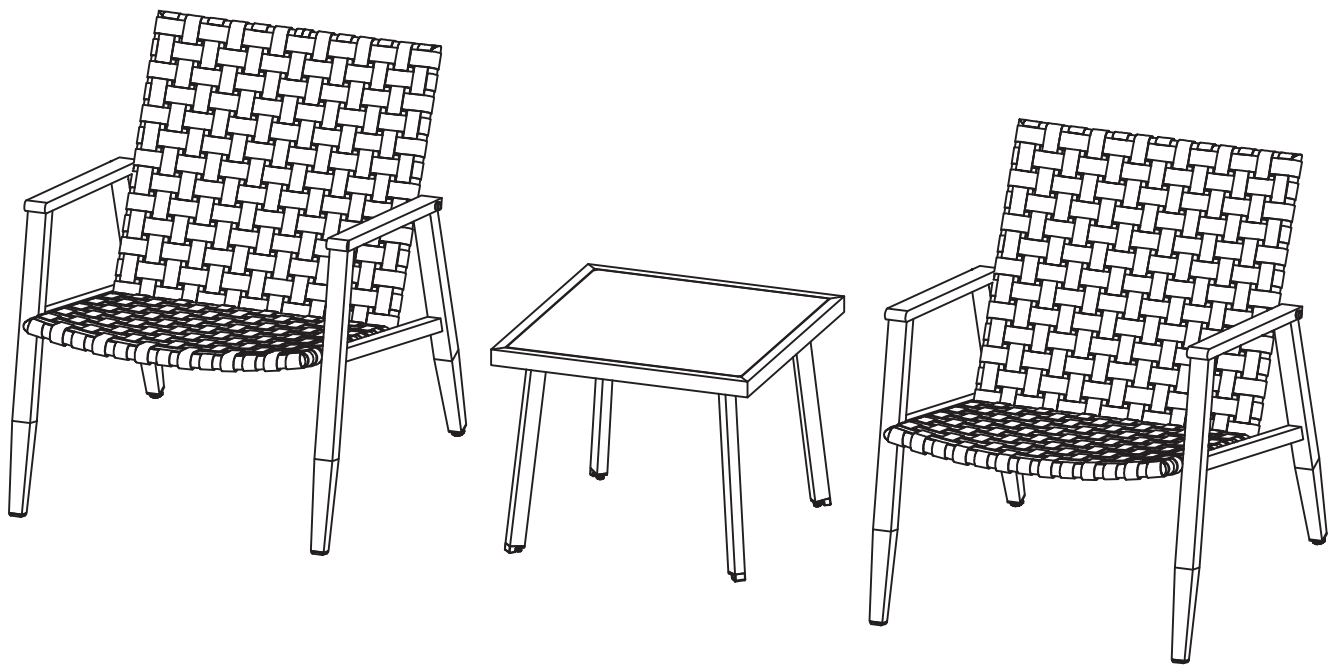

Thanks for choosing Comlax FIELD collection.
If you have any questions, inquires or suggestions, pls contact us directly.
Always best services stand by.
Customer service email: info@comlax-intl.com
Attention: Products returned directly without permission will be rejected!

 **WARNING:** This product can expose you to chemicals including Di(2-ethylhexyl) phthalate (DEHP), which is known to the State of California to cause cancer, and birth defects or other reproductive harm. For more information go to www.P65Warnings.ca.gov.