

# Installation & Assembly

---

▼  
TV STAND

## TOOLS REQUIRED

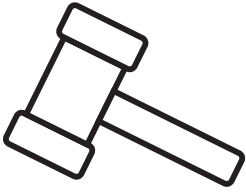

Phillips screwdriver  
(Not included )

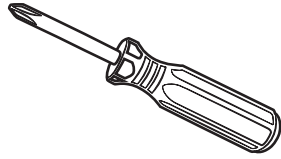

Hammer  
(Not included)

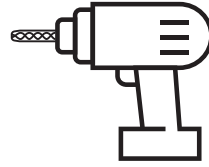

Drill  
(Not included)

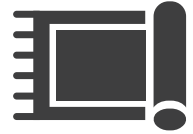

Protective blanket  
(Not included)



## ATTENTION

Keep children and pets away while assembling.



# HOW TO USE CAM LOCKS

## CAM LOCK FASTENING SYSTEM

This Cam Lock Fastening System will be used throughout the assembly process.

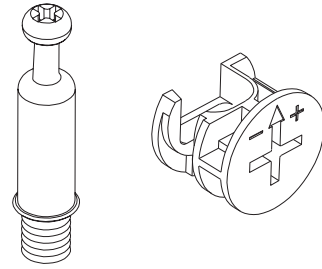

1

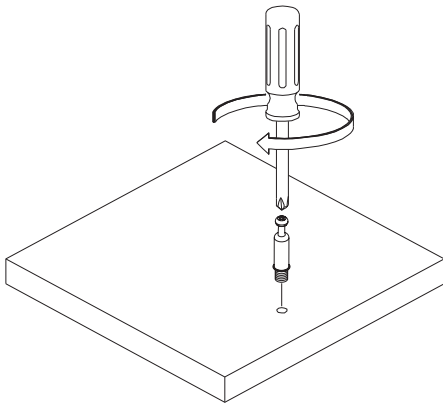

2

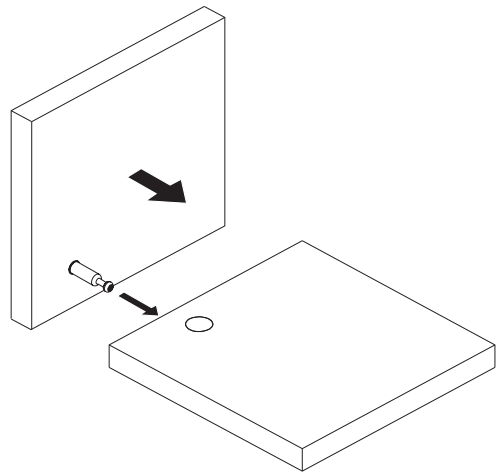

3

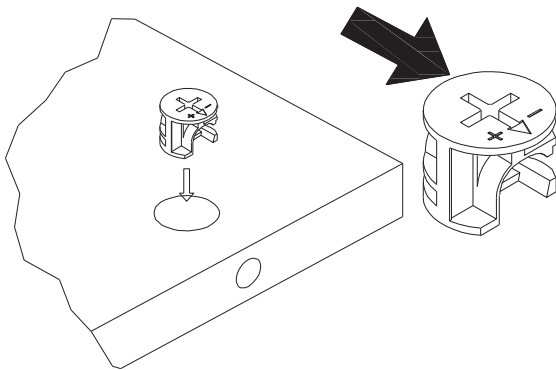

4

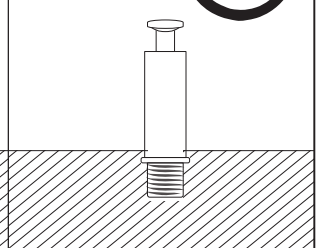
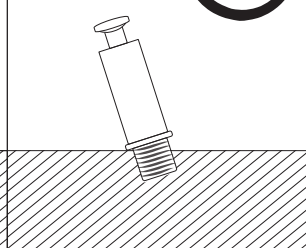
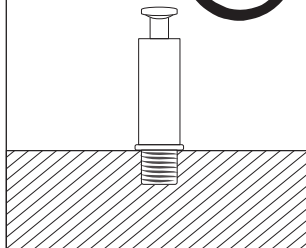
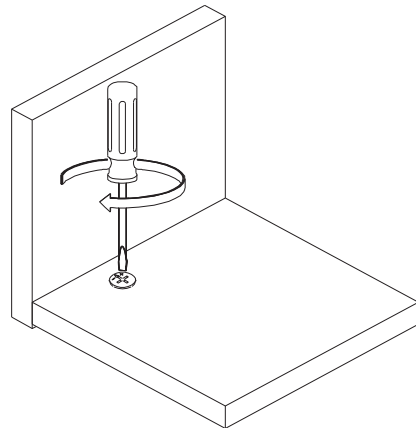

## INTRODUCTION

Thank you for purchasing our products. Committed to providing customers with the best quality products and service has always been our lifelong goal. Before using the product, please read this instruction manual carefully to ensure correct use. Keep the instruction manual in a place where the user can find it at any time. If you need further assistance, please contact the customer service online.

---

## PRECAUTIONS

1. There are many components and accessories in the package. Each component and accessory is labeled with a letter or a number, check carefully before using any of them. Keep them away from children to prevent accidents.
2. Please install the product on a clean and soft underlay (such as carpet or cardboard) to avoid scratching or damaging the surface of the product.
3. The main components of the product is relatively heavy. Please pay attention to safety during installation.
4. The product is not stable during installation. Please do not move it randomly before it is completely installed.
5. If you have any questions during installation, please contact the customer service in time.

**\* PLEASE BE SURE TO FOLLOW THE INSTALLATION STEPS IN THE MANUAL TO AVOID UNNECESSARY LOSSES CAUSED BY IMPROPER INSTALLATION.**

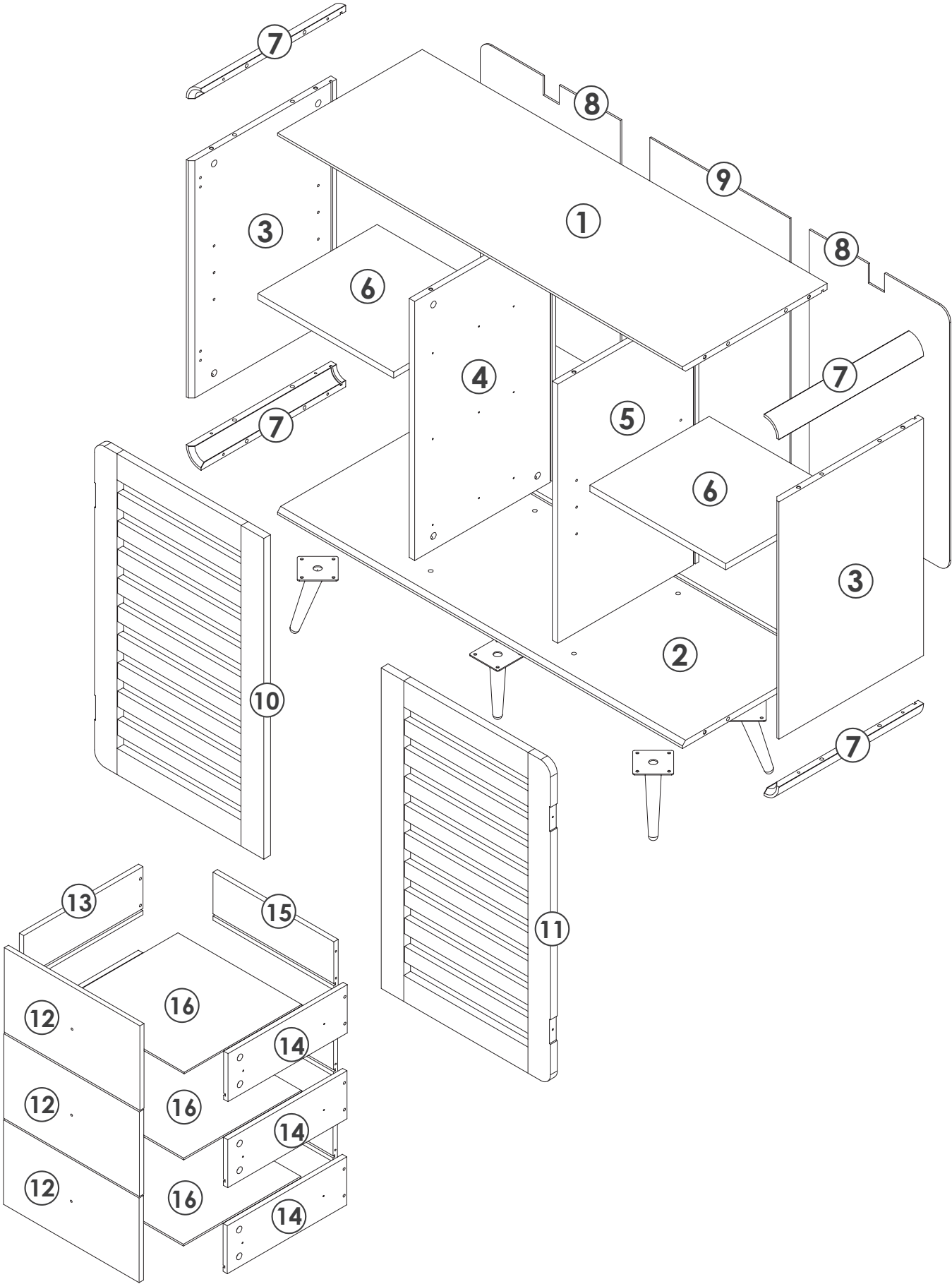

# PRODUCT ASSEMBLY

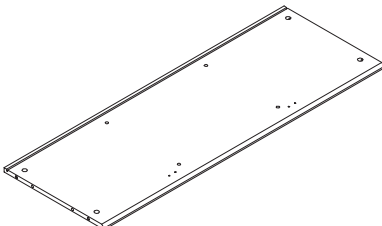
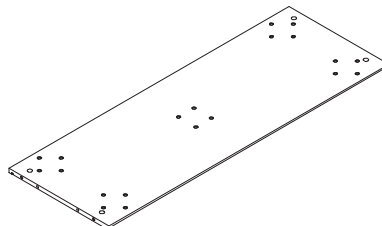
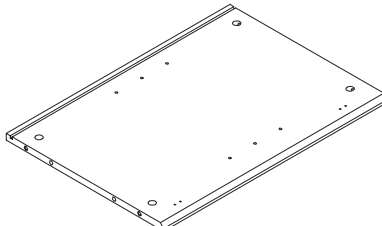
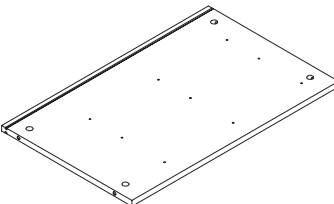
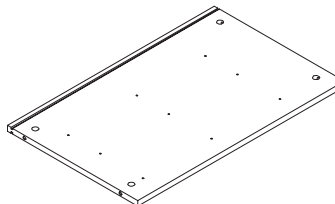
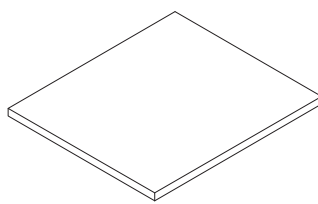
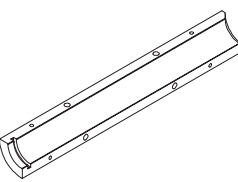
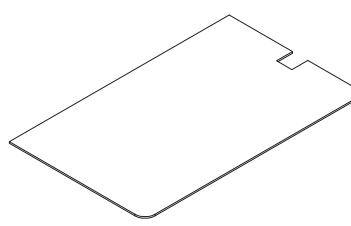
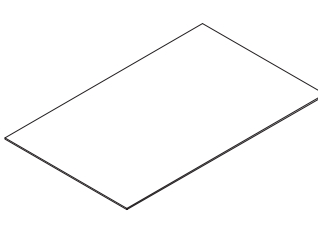
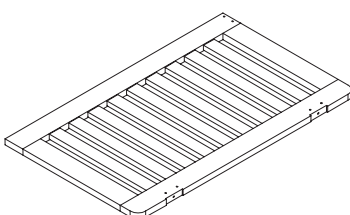
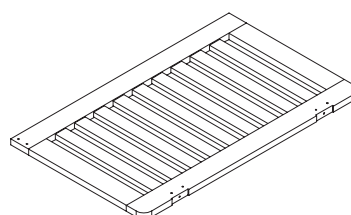
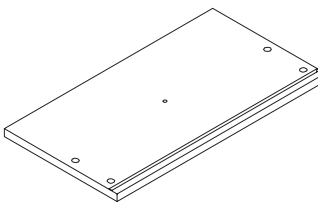
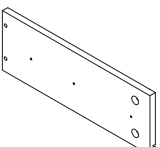
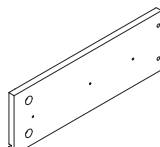
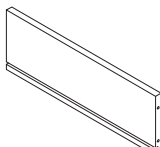
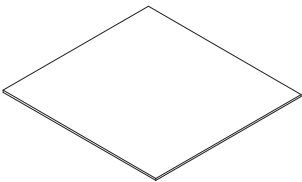

# PARTS LIST

<p>① 1120x400x15 mm</p>  <p>x1</p>	<p>② 1120x400x15 mm</p>  <p>x1</p>	<p>③ 568x400x15 mm</p>  <p>x2</p>	
<p>④ 620x390x15 mm</p>  <p>x1</p>	<p>⑤ 620x390x15 mm</p>  <p>x1</p>	<p>⑥ 376x356x15mm</p>  <p>x2</p>	
<p>⑦ 41x41x400 mm</p>  <p>x4</p>	<p>⑧ 628x387x4 mm</p>  <p>x2</p>	<p>⑨ 628x387x4 mm</p>  <p>x1</p>	
<p>⑩ 614x374x15 mm</p>  <p>x1</p>	<p>⑪ 614x374x15 mm</p>  <p>x1</p>	<p>⑫ 202x375x12 mm</p>  <p>x3</p>	
<p>⑬ 330x115x12 mm</p>  <p>x3</p>	<p>⑭ 330x115x12 mm</p>  <p>x3</p>	<p>⑮ 334x115x12 mm</p>  <p>x3</p>	<p>⑯ 342x325x4 mm</p>  <p>x3</p>

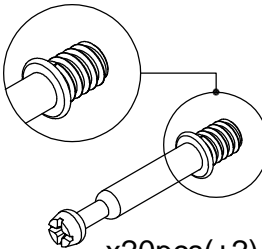
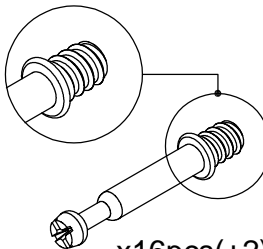
# HARDWARES LIST

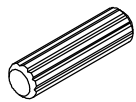
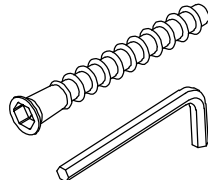
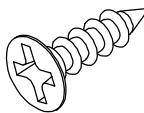
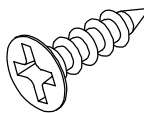
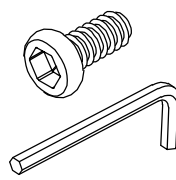
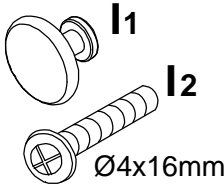
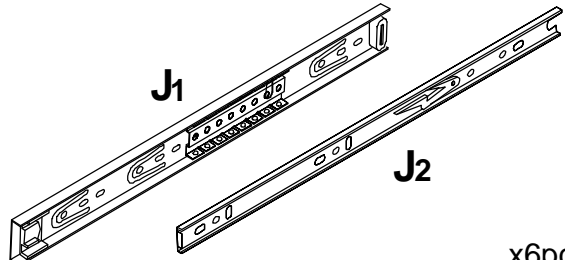
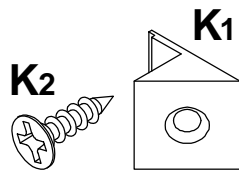
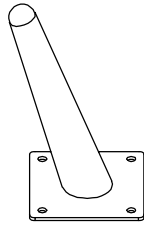
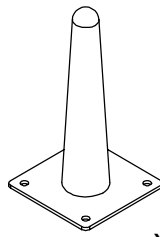
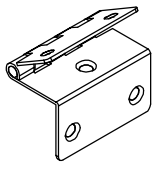
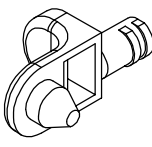
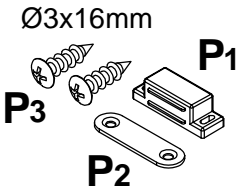
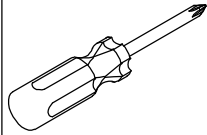
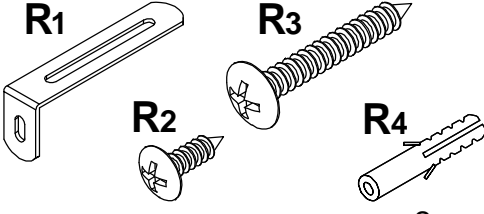
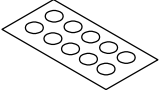
<p><b>A</b> Ø6x40mm</p>  <p>x20pcs(+2)</p>	<p><b>B</b> Ø6x40mm</p>  <p>x16pcs(+2)</p>	<p><b>C</b> Ø15x9.5mm</p>  <p>x36pcs(+1)</p>	<p><b>D</b> Ø8x30mm</p>  <p>x16pcs(+1)</p>
<p><b>E</b> Ø5x40mm</p>  <p>x12pcs(+1)</p>	<p><b>F</b> Ø3x12mm</p>  <p>x22pcs(+2)</p>	<p><b>G</b> Ø3.5x14mm</p>  <p>x38pcs(+1)</p>	<p><b>H</b> Ø6x10mm</p>  <p>x20pcs(+1)</p>
<p><b>I</b> = I<sub>1</sub> + I<sub>2</sub></p>  <p>Ø4x16mm</p> <p>x3pcs</p>	<p><b>J</b> = J<sub>1</sub> + J<sub>2</sub></p>  <p>x6pcs</p>	<p><b>K</b> = K<sub>1</sub> + K<sub>2</sub></p>  <p>Ø3x16mm</p> <p>x18pcs</p>	
<p><b>L</b></p>  <p>x4pcs</p>	<p><b>M</b></p>  <p>x1pc</p>	<p><b>N</b></p>  <p>x4pcs</p>	<p><b>O</b></p>  <p>x8pcs</p>
<p><b>P</b> = P<sub>1</sub> + P<sub>2</sub> + P<sub>3</sub></p> <p>Ø3x16mm</p>  <p>x2pcs</p>	<p><b>Q</b></p>  <p>x1pc</p>	<p><b>R</b> = R<sub>1</sub> + R<sub>2</sub> + R<sub>3</sub> + R<sub>4</sub></p>  <p>x2pcs</p>	<p><b>S</b></p>  <p>x38pcs(+2)</p>

# INSTALLATION INSTRUCTION

---

## **⚠ Attention**

This part (J) comes pre-assembled for shipping purposes and must be disassembled into 2 parts and then installed separately.

---

1). Extend the slider bracket all the way forward.

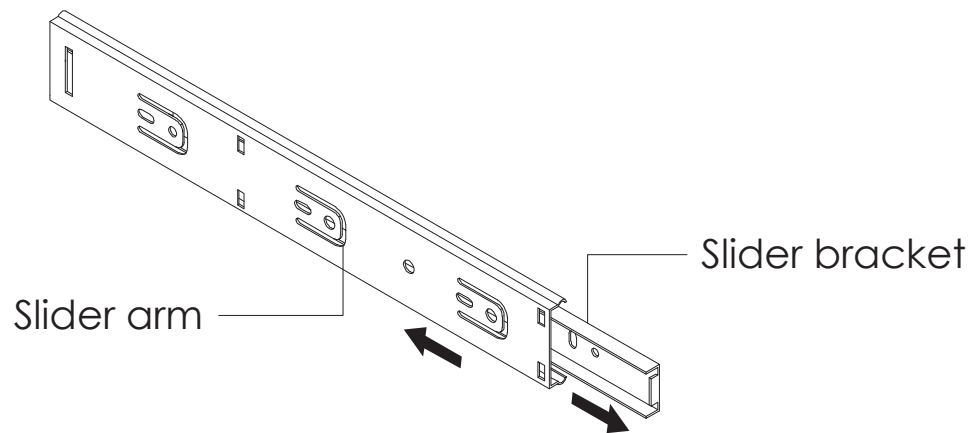

2). Pull the slider arm's plastic release lever upward and pull the slider bracket completely out.

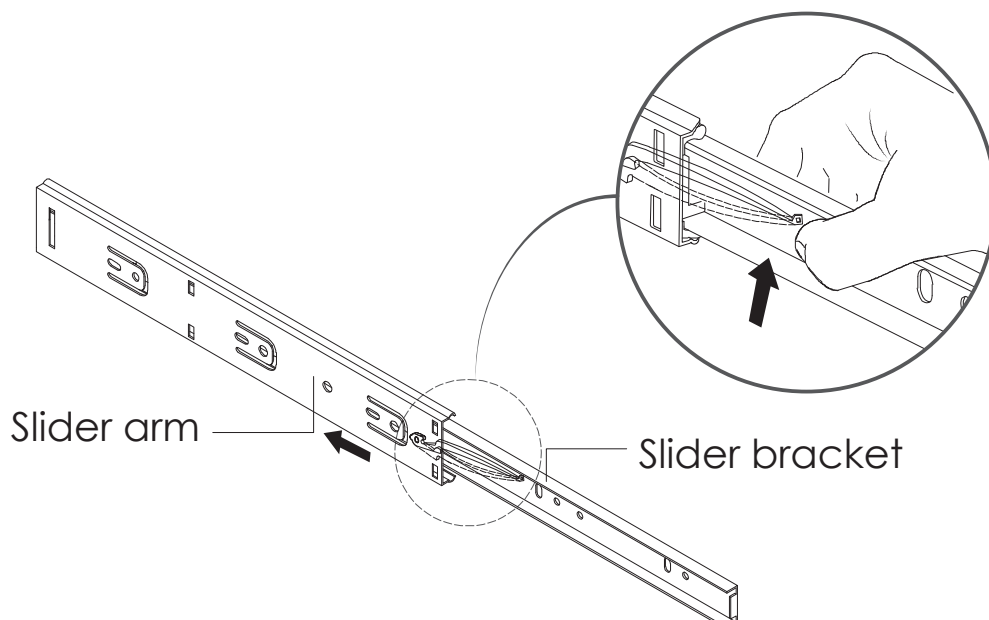

# 01

H x20pcs



L x4pcs

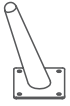

M x1pc

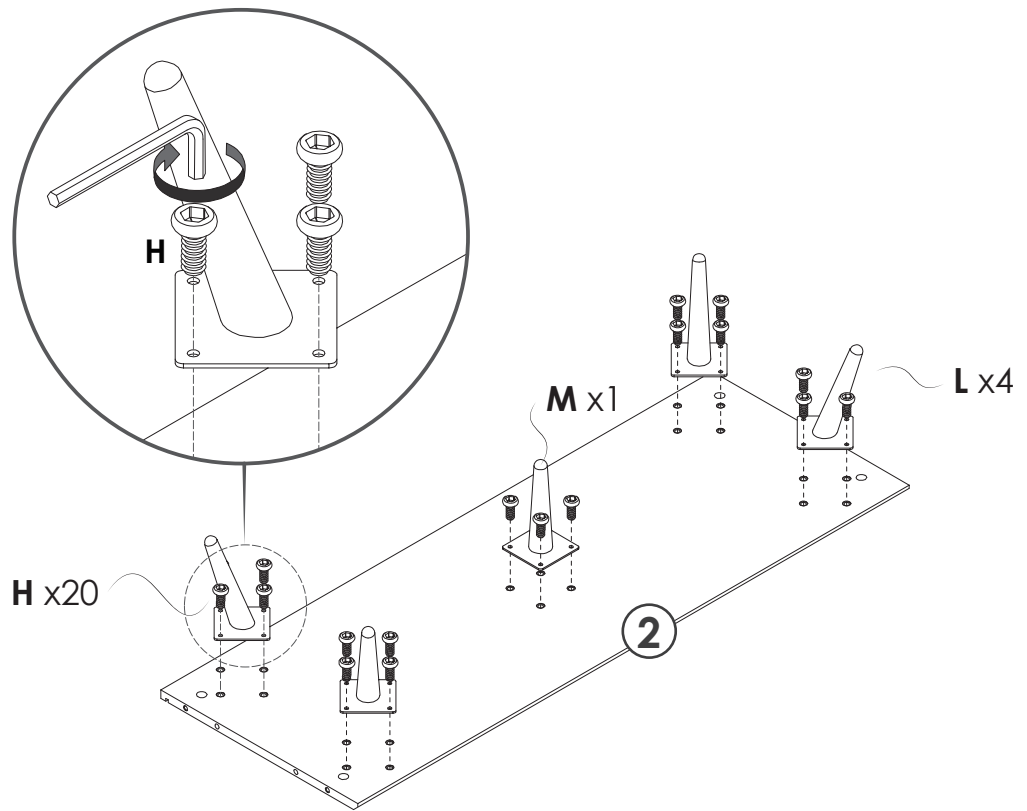
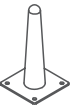

FINISHED



# 02

D x4pcs

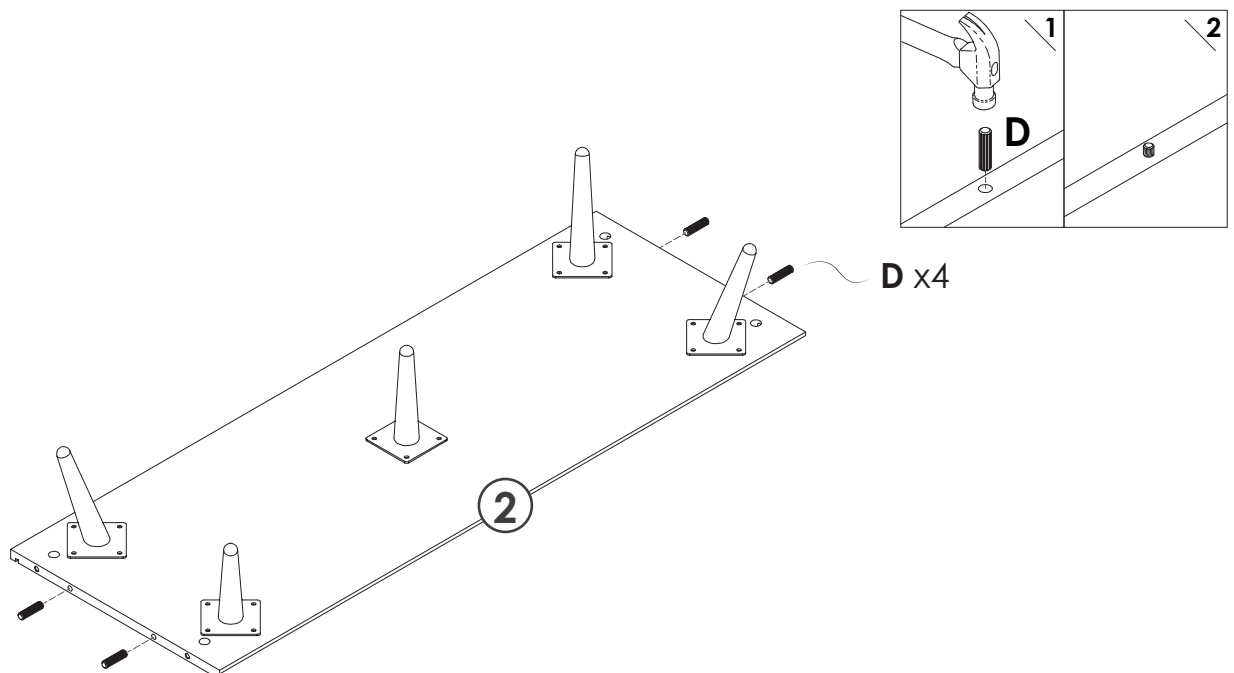

# 03

**B** x16pcs

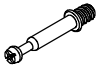

Ø6x40mm

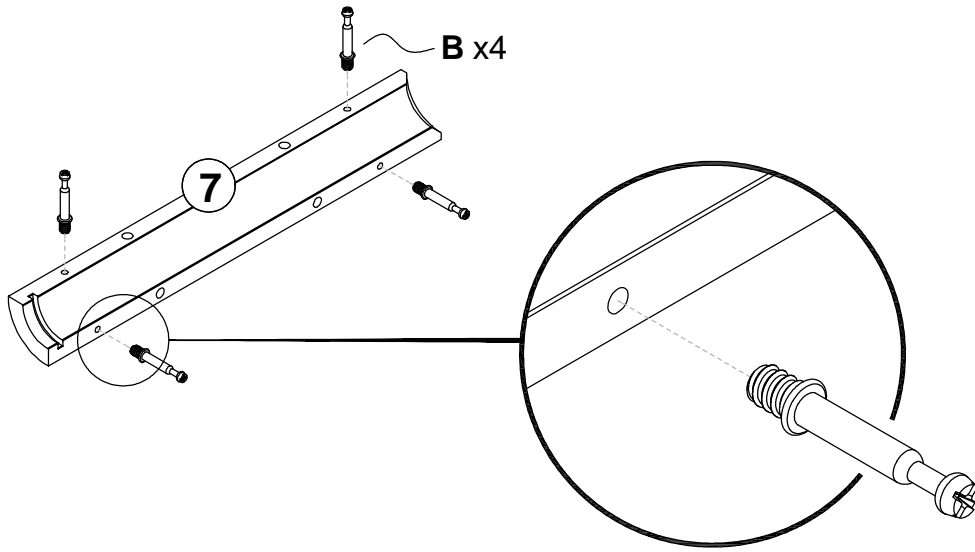

x4

# 04

**C** x4pcs



Ø15x9.5mm

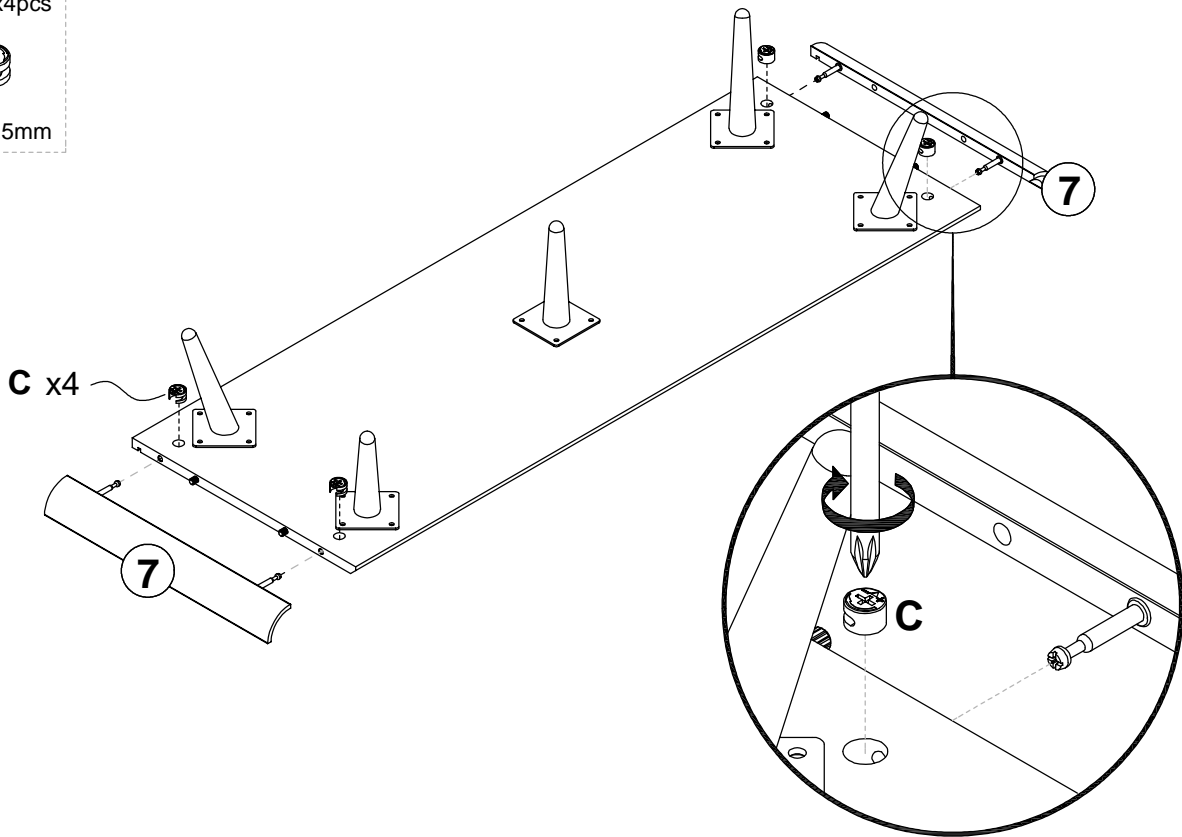

# 05

**D** x8pcs



Ø8x30mm

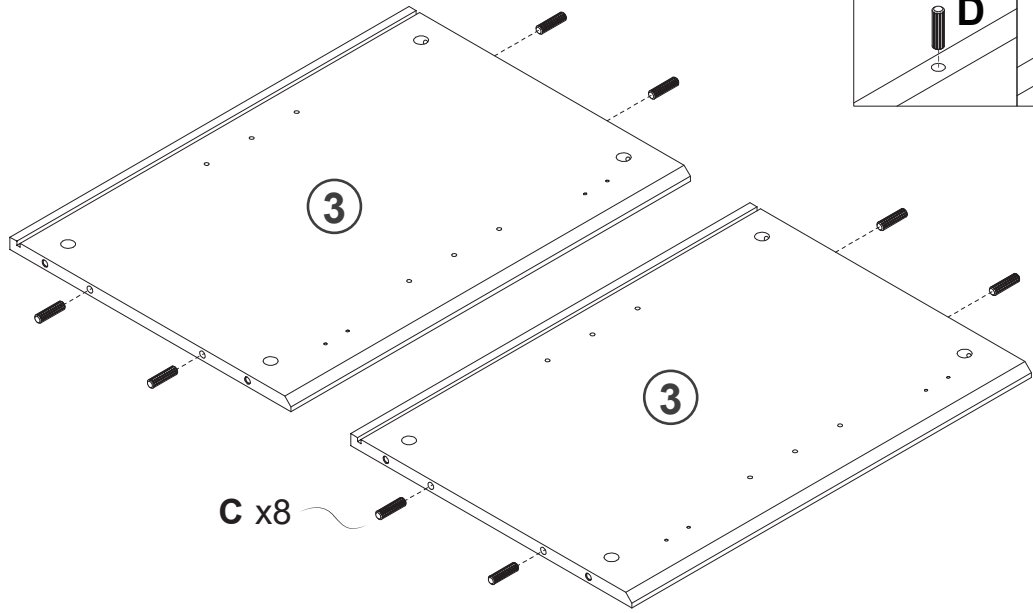
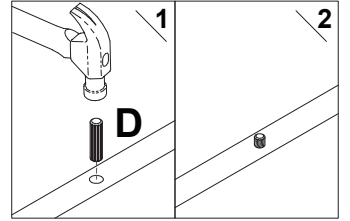

# 06

**A** x4pcs



Ø6x40mm

**C** x4pcs



Ø15x9.5mm

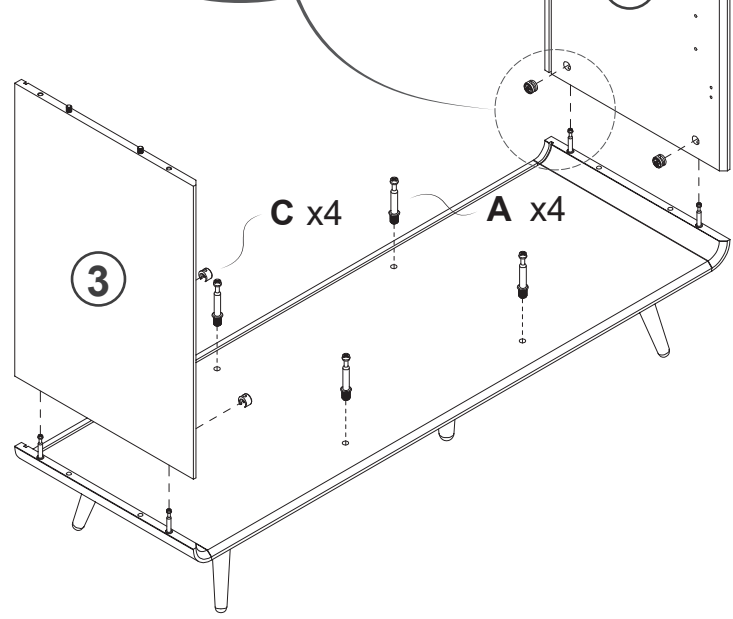
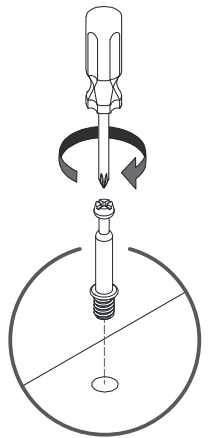
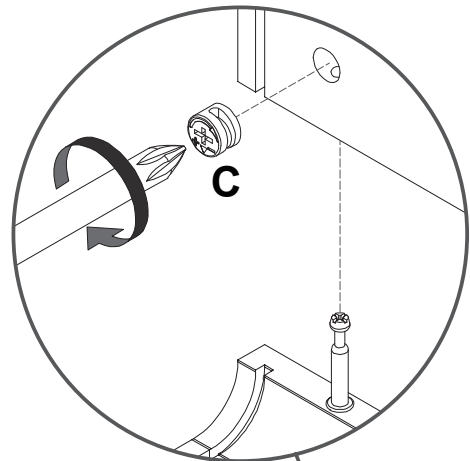

# 07

G x18pcs



Ø3.5x14mm

J1 x6pcs

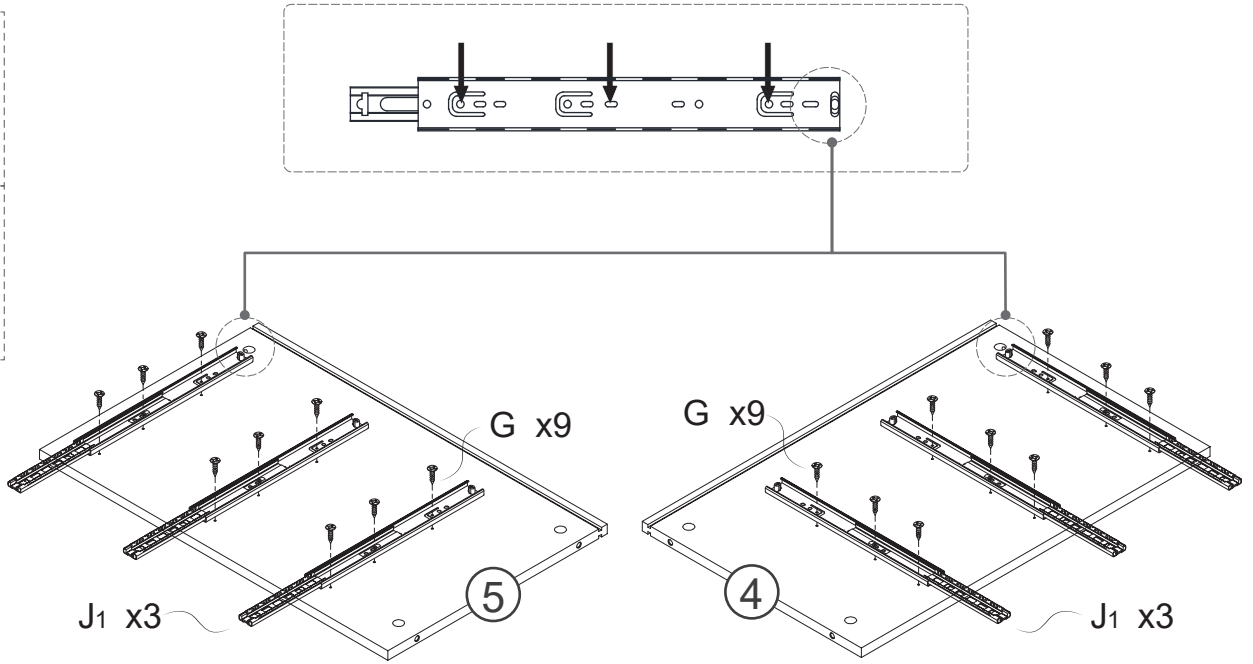
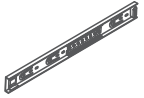

# 08

C x4pcs



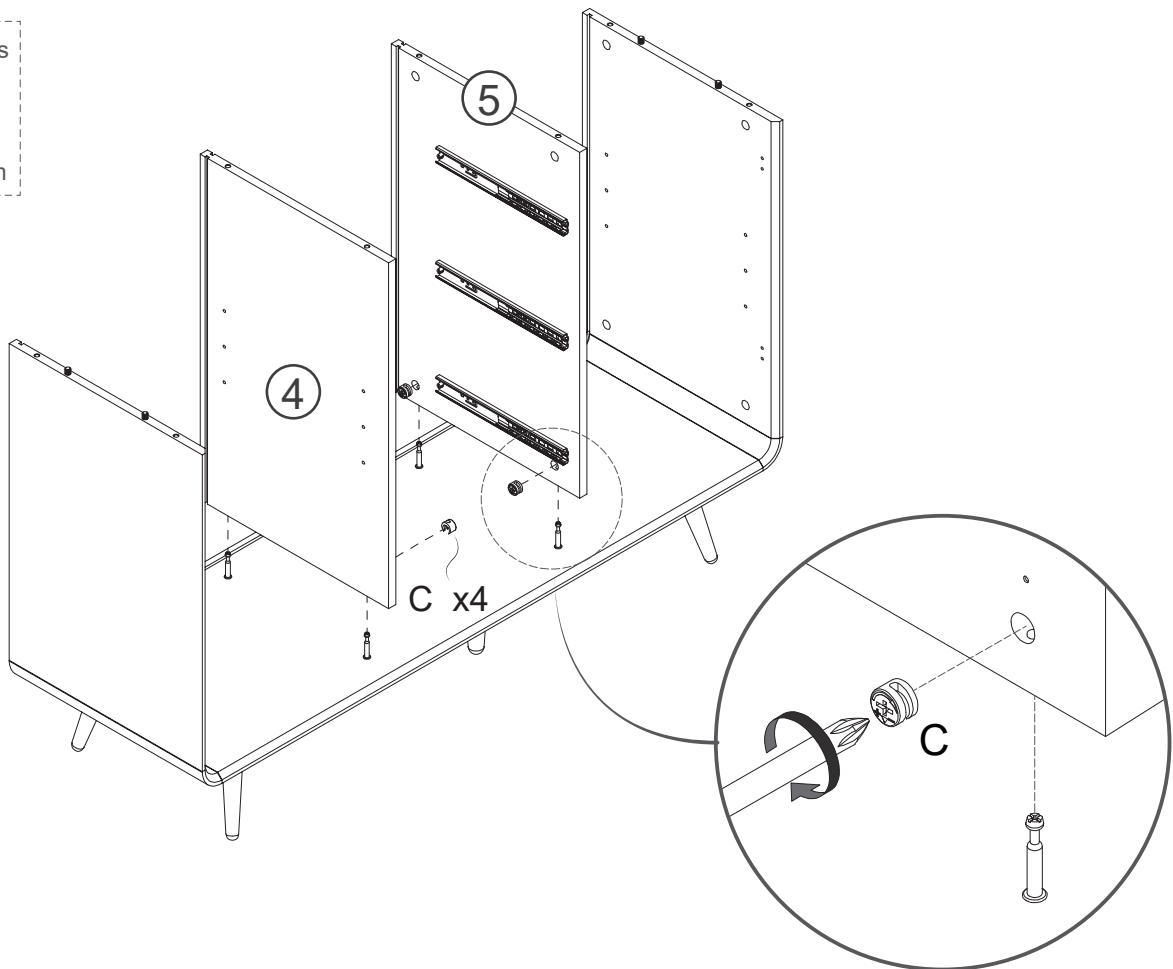

Ø15x9.5mm

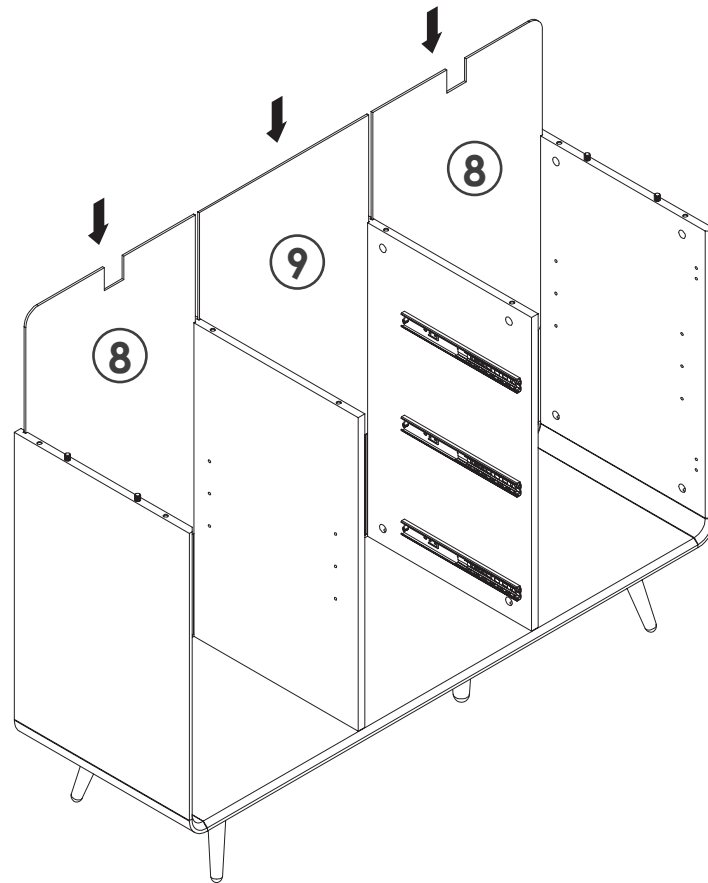

# 09



# 10

- P1** x2pcs  
  
Ø3x16mm
- P3** x4pcs  
  
Ø3x16mm

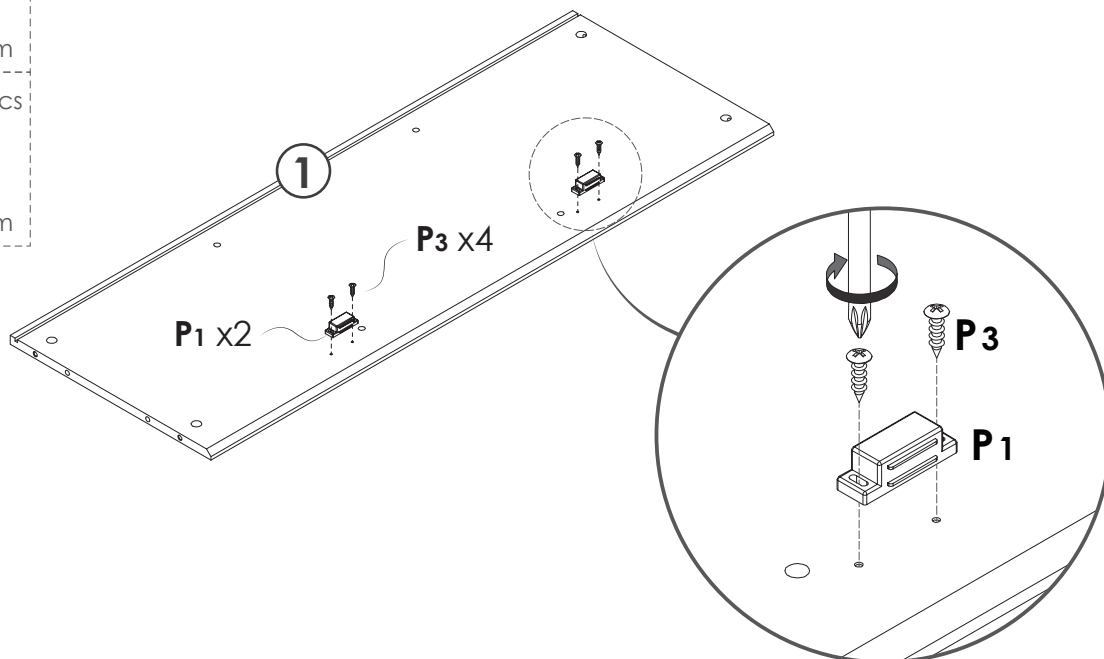

# 11

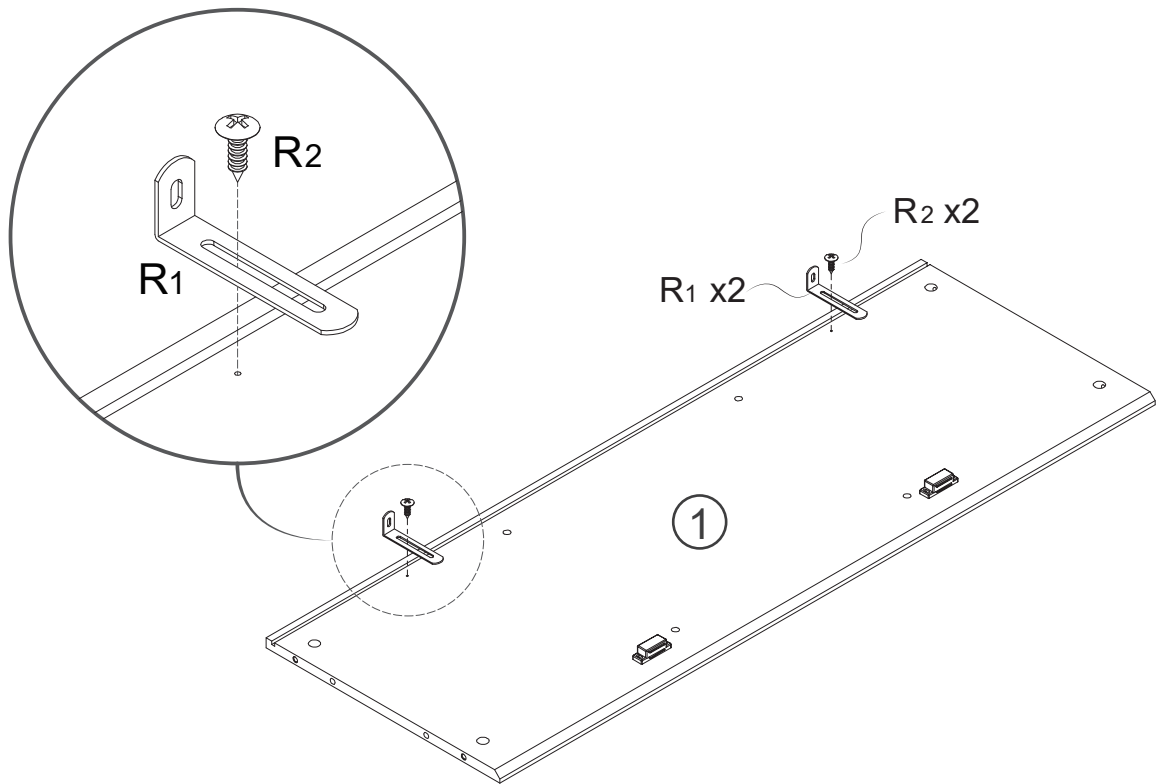
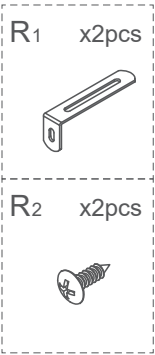

# 12

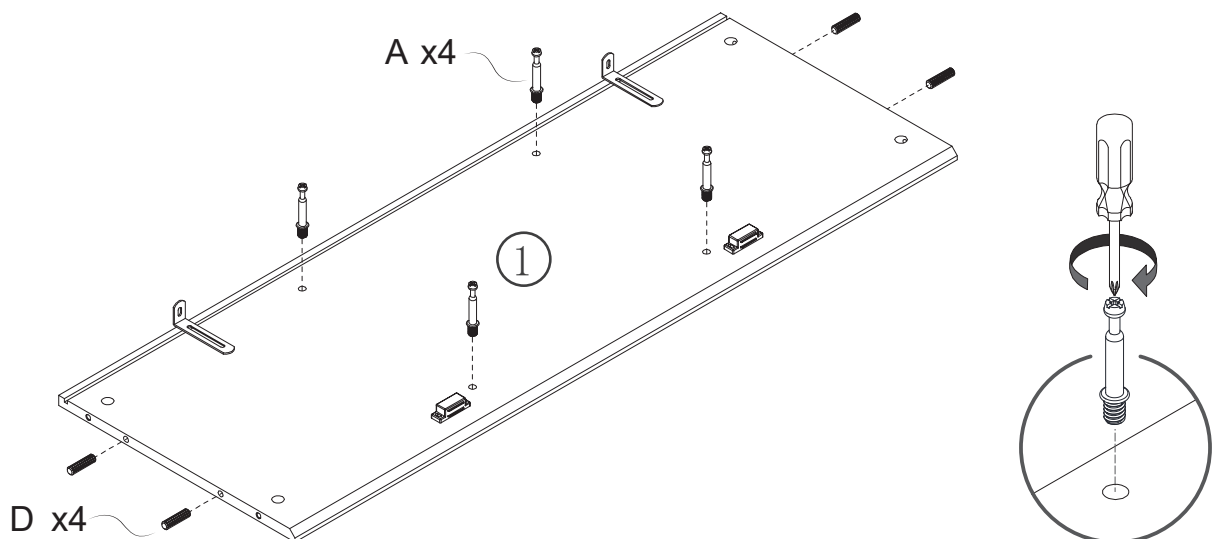
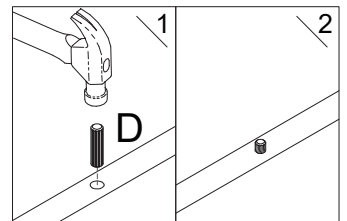
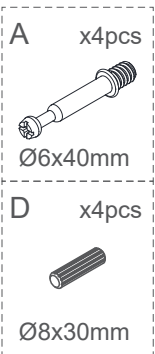

# 13

C x4pcs  
Ø15x9.5mm

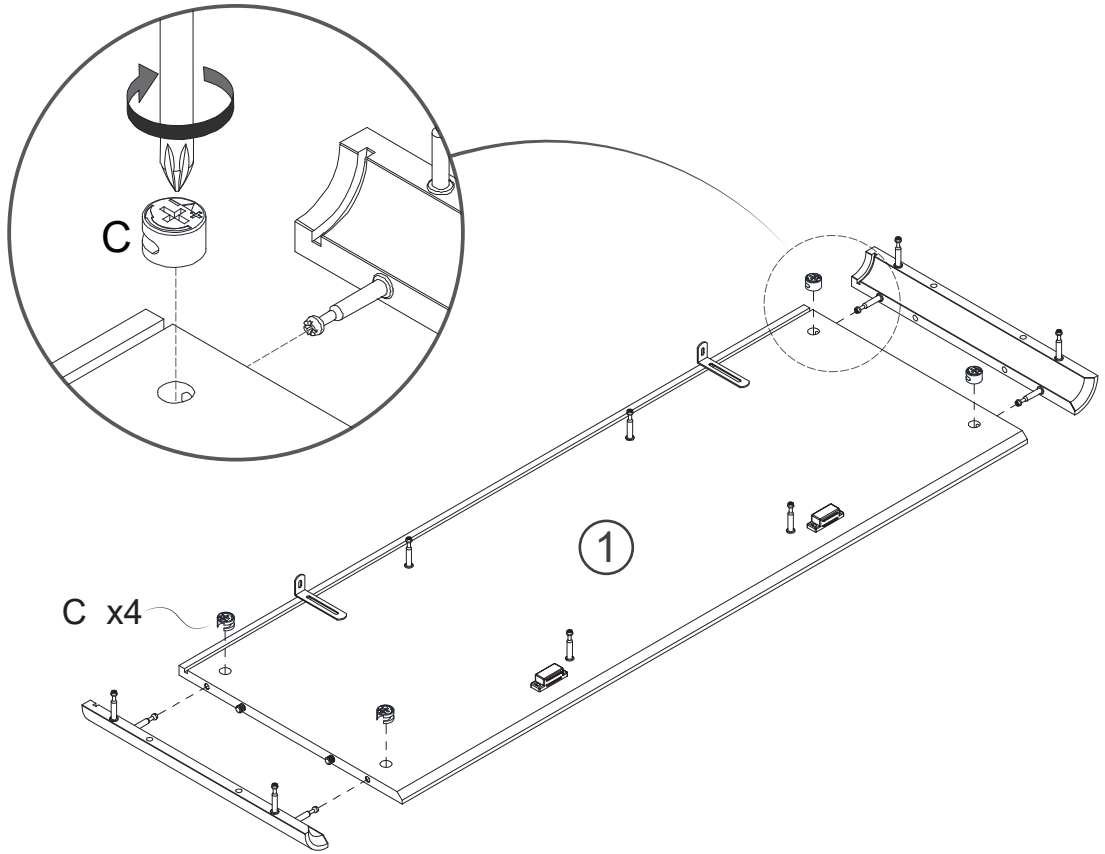

# 14

C x8pcs  
Ø15x9.5mm

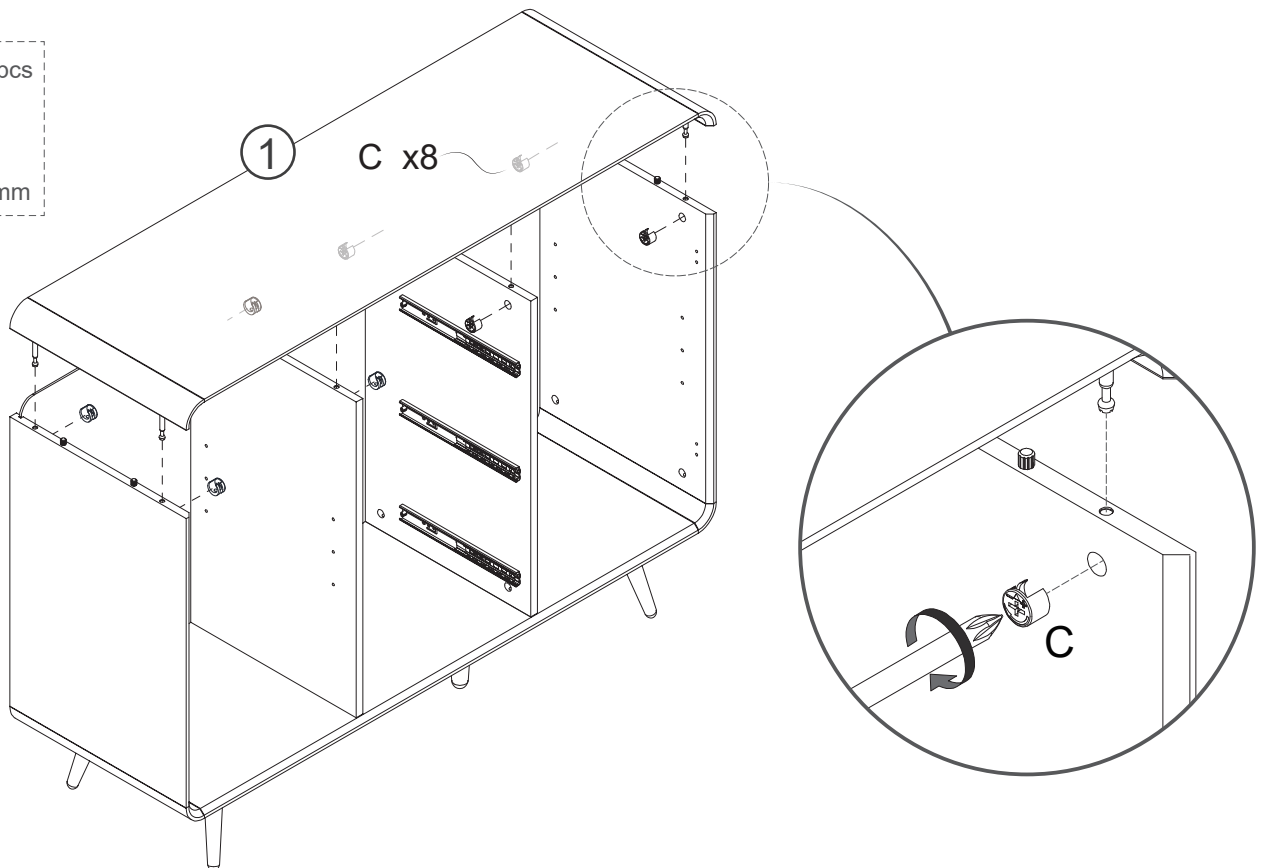

# 15

**F** x4pcs



Ø3x12mm

**P2** x2pcs

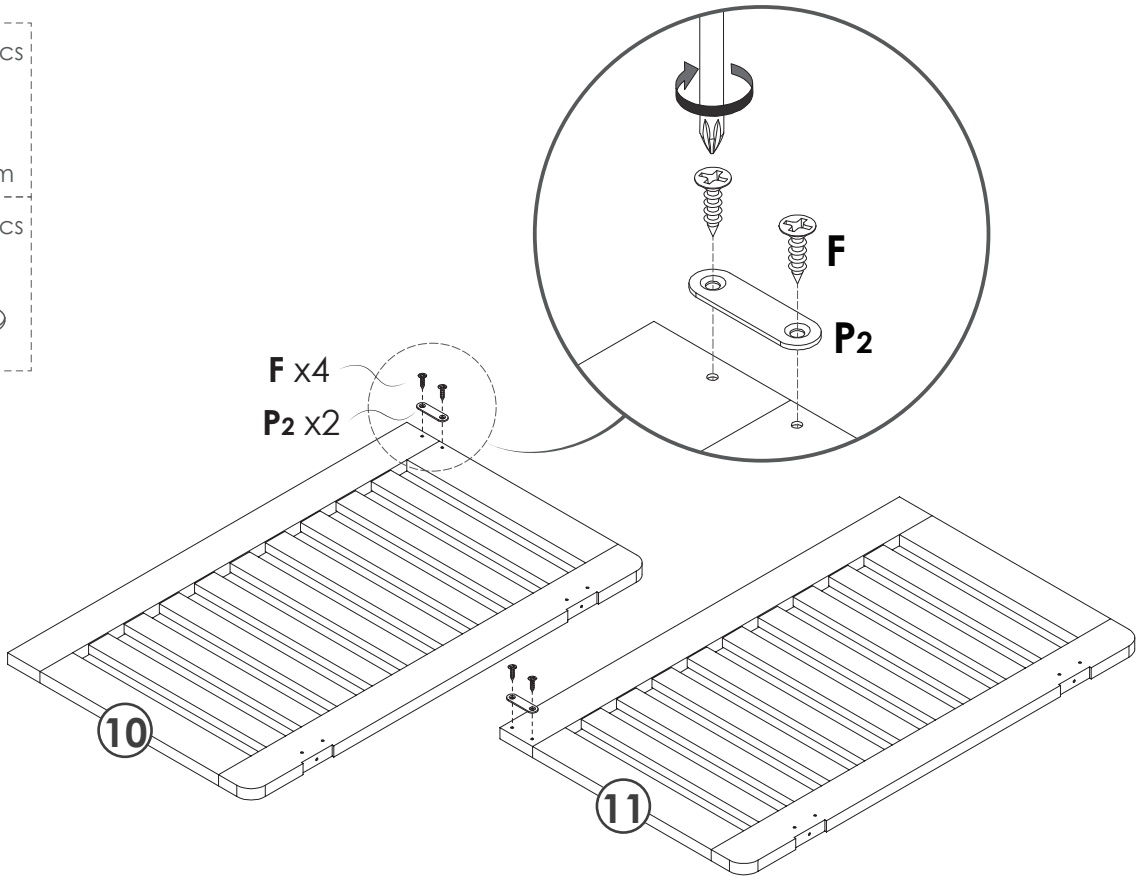
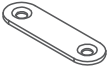

# 16

**G** x12pcs



Ø3.5x14mm

**N** x4pcs

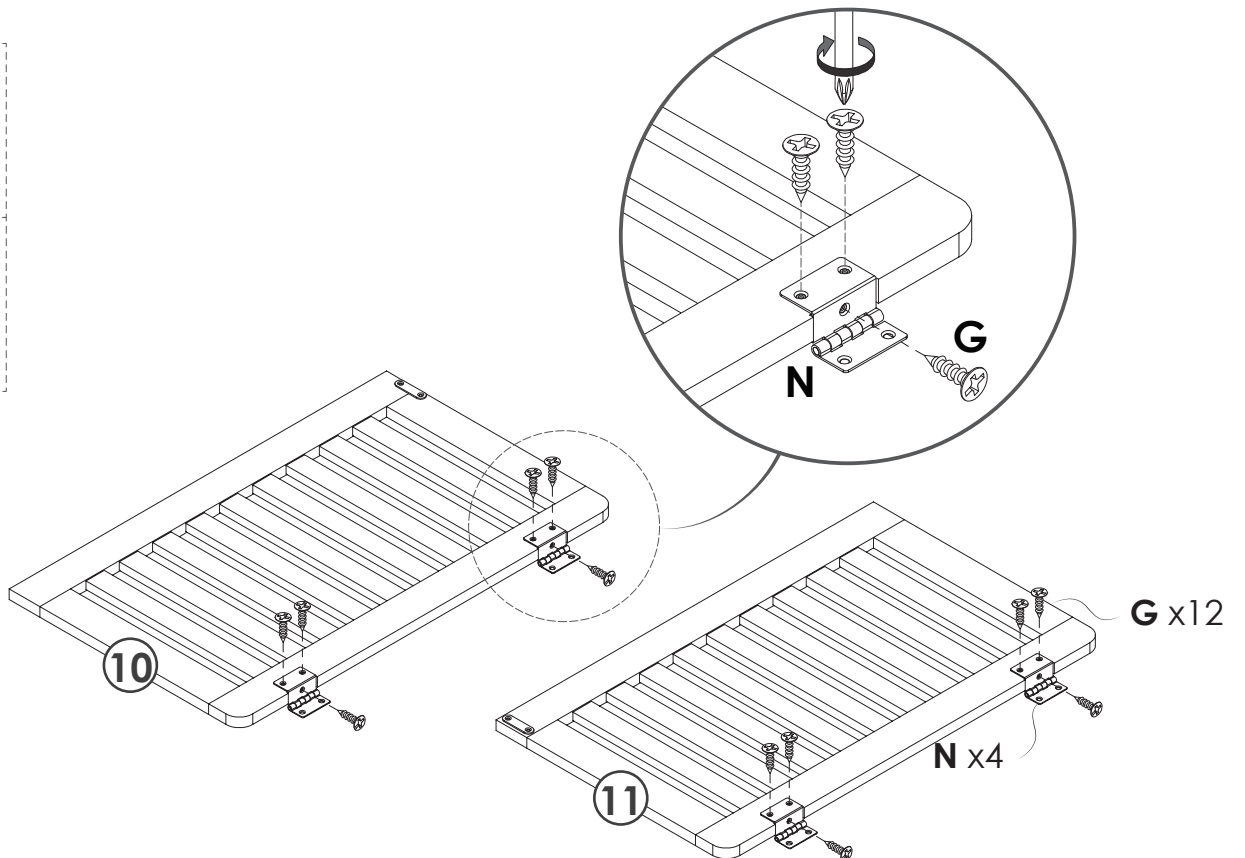

# 17

**G** x8pcs



Ø3.5x14mm

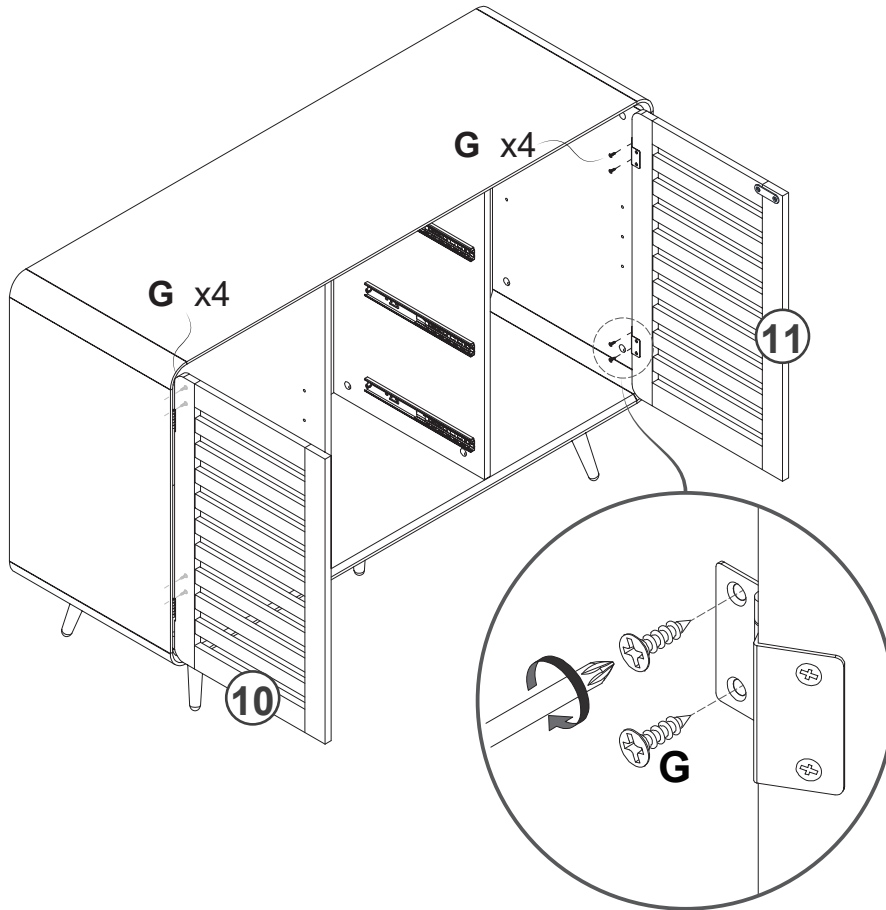

# 18

**O** x8pcs



Ø3x16mm

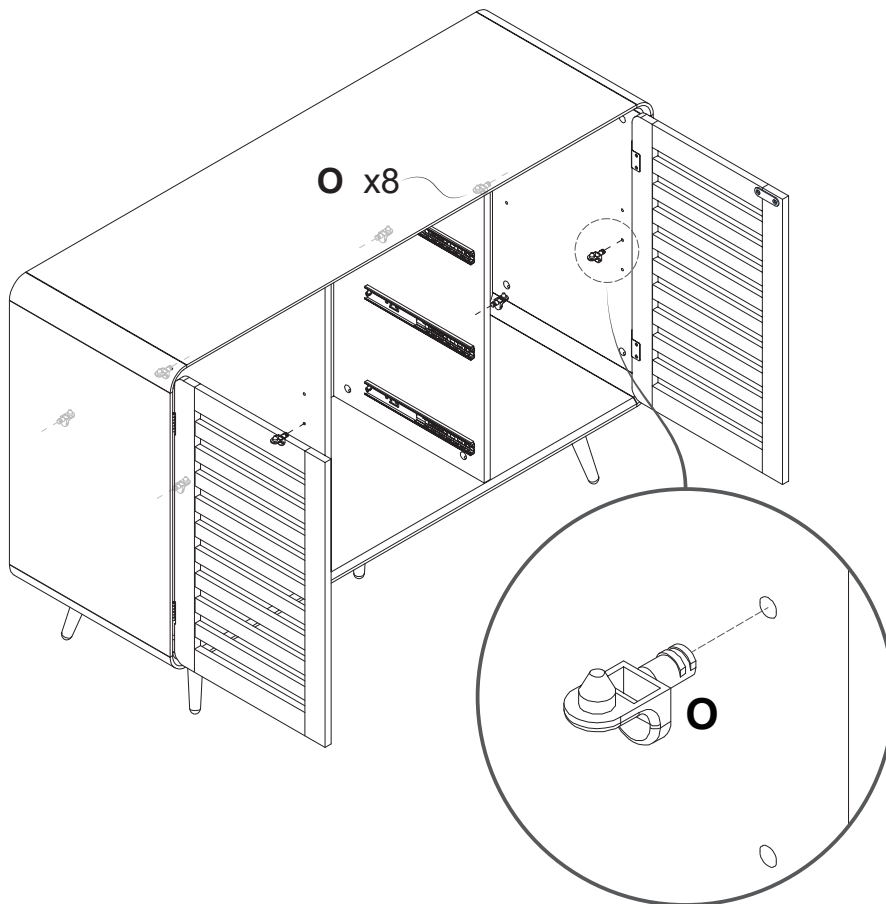

19

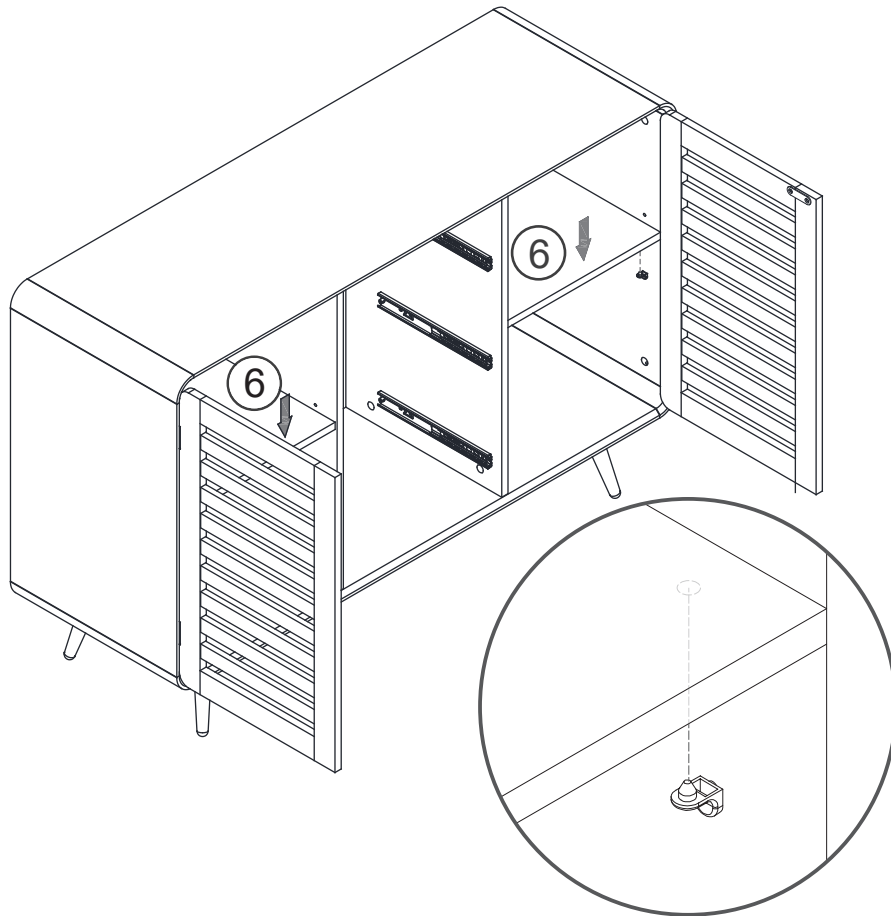

20

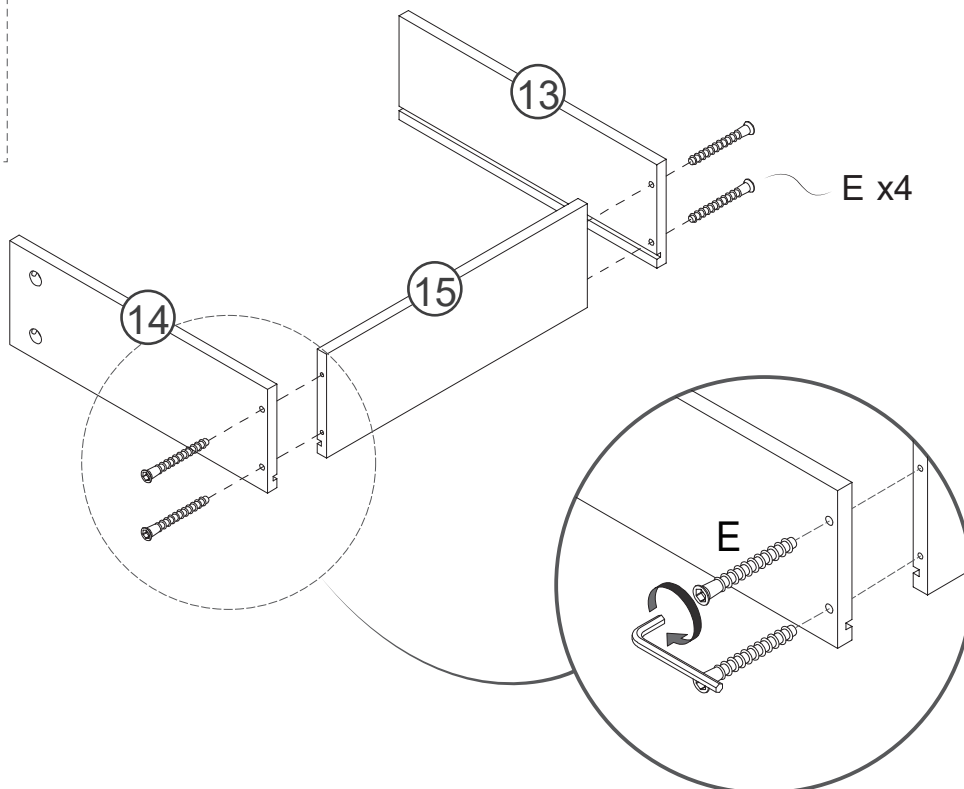
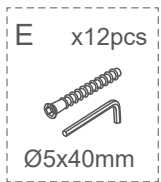

# 21

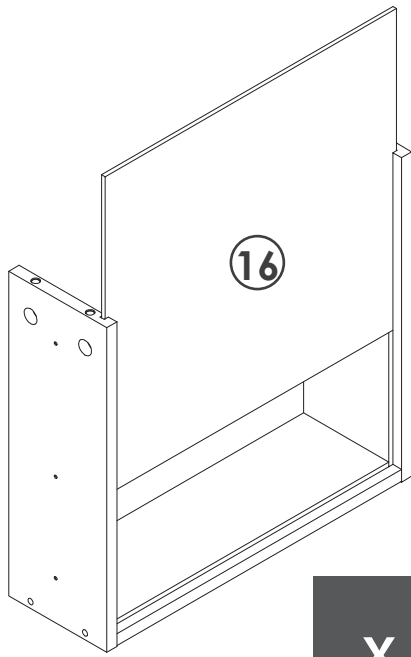

16

x 3

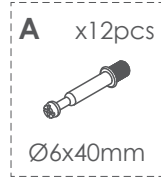

A x12pcs

Ø6x40mm

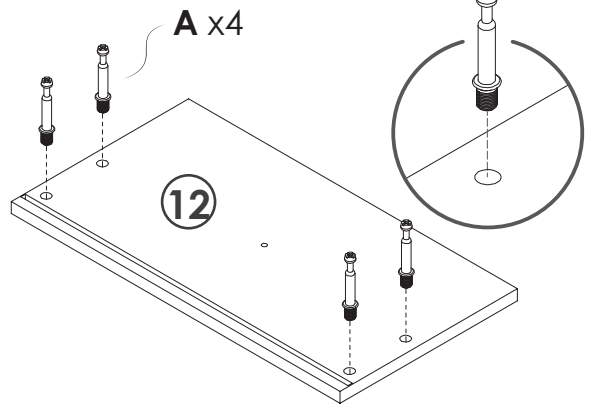

12

A x4

x 3

1 2  
3 4



C x12pcs

Ø15x9.5mm

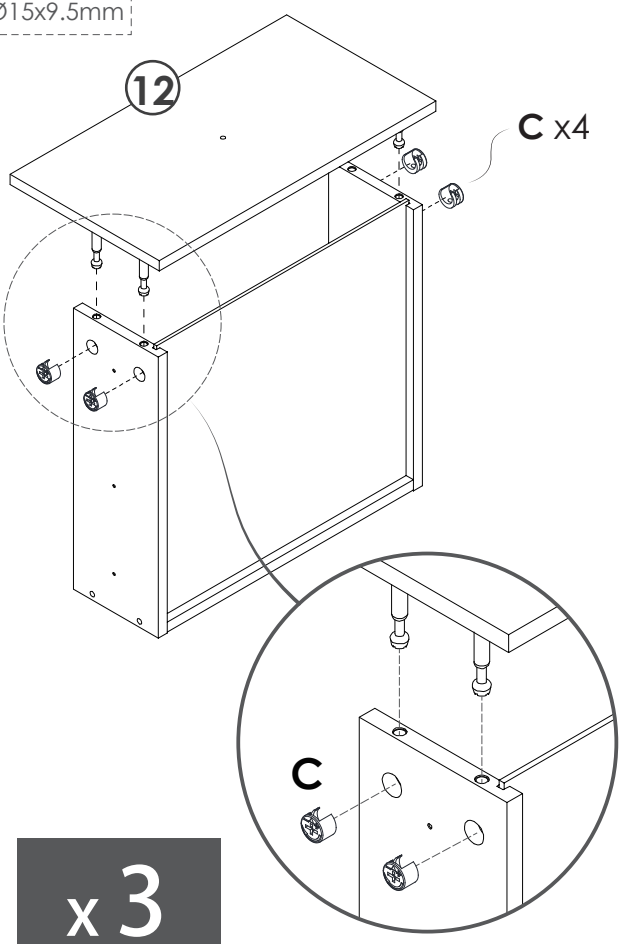

12

C x4

x 3

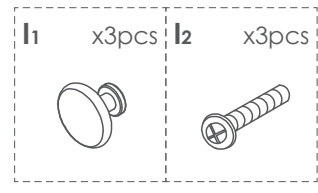

I1 x3pcs

I2 x3pcs

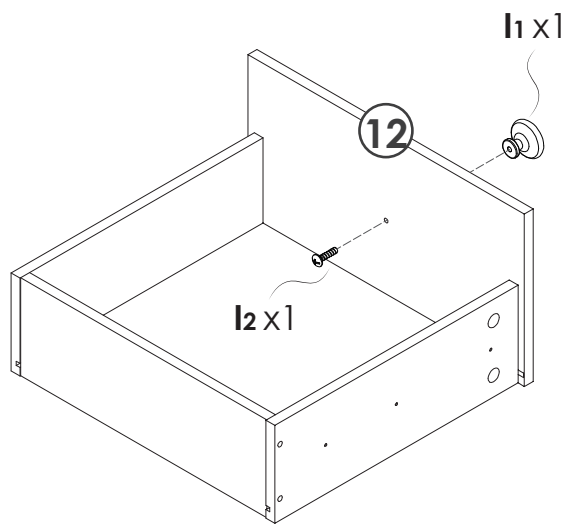

12

I1 x1

I2 x1

x 3

# 22

F x18pcs



Ø3x12mm

J2 x6pcs

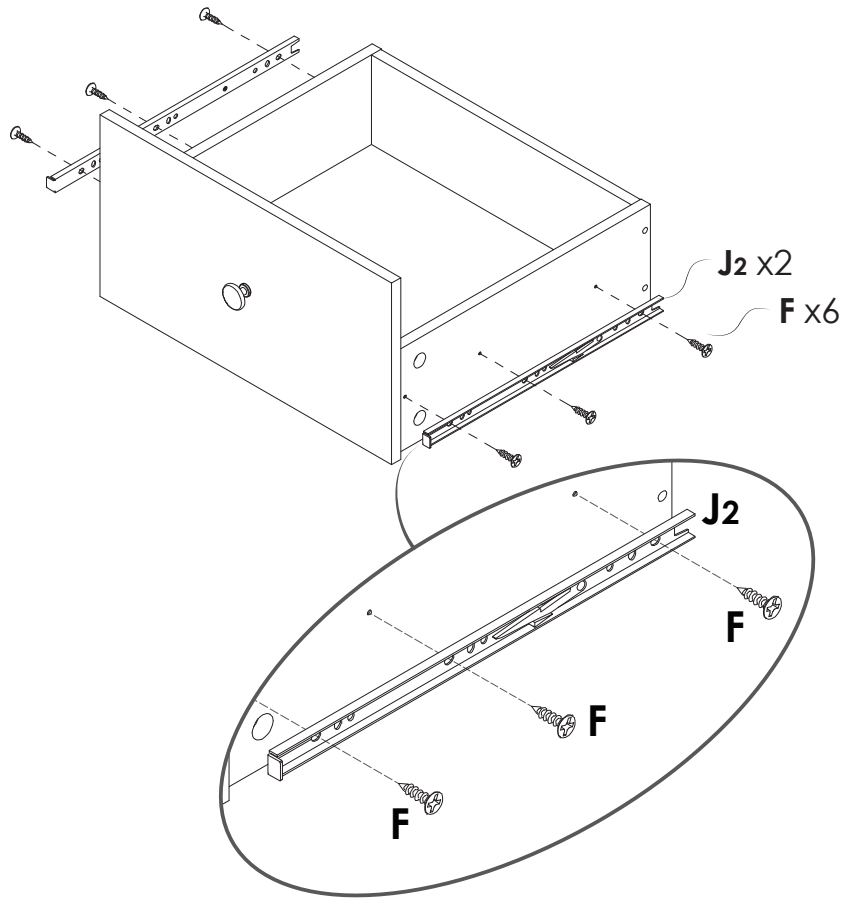
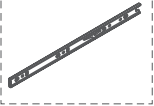

x3

# 23

1

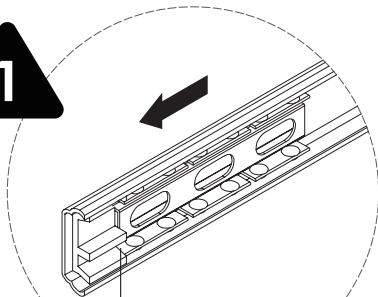

Reached the limit position

2

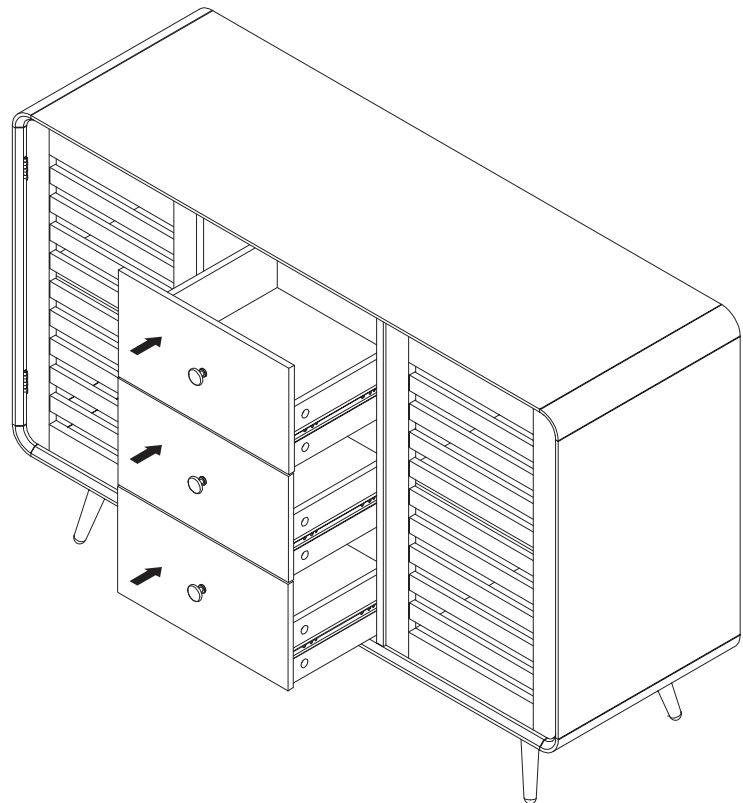
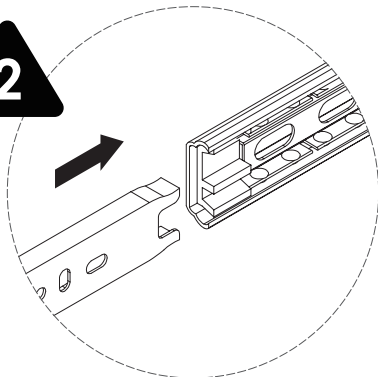

# 24

K1 x18pcs



K2 x18pcs



Ø3x16mm

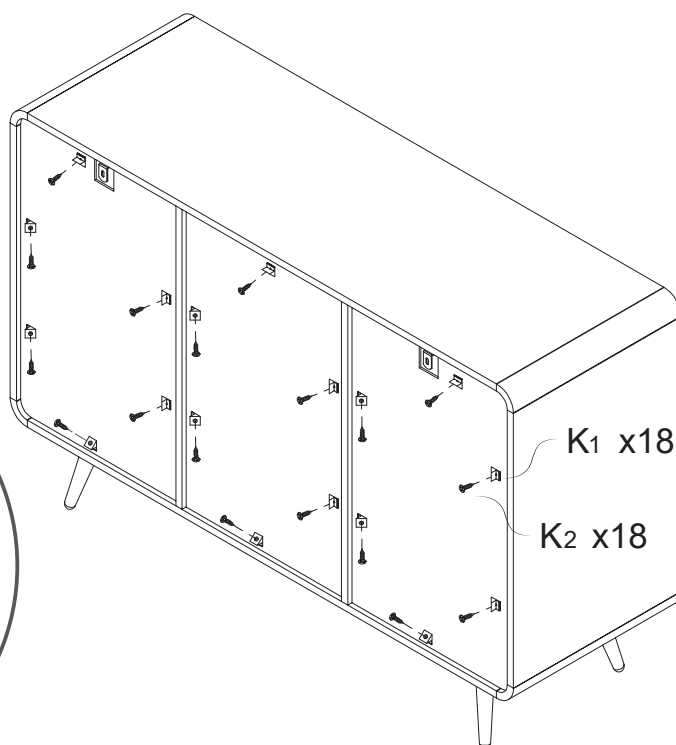
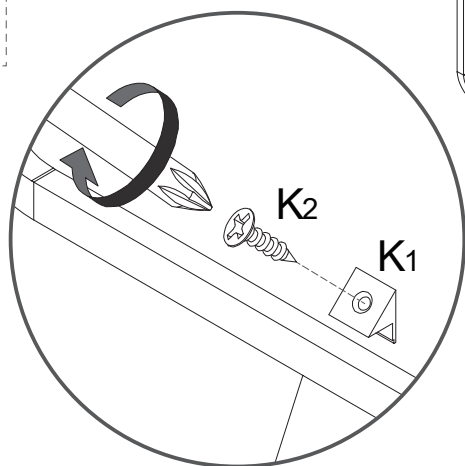

# 25

S x38pcs

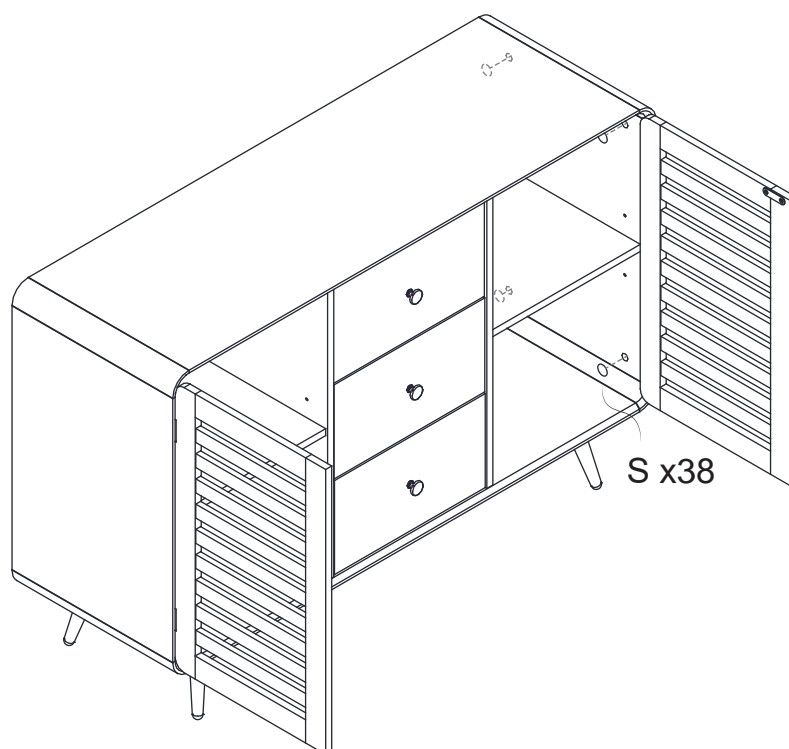
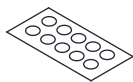

# 26

## Mandatory!

For safety reasons, we recommend you follow these instructions to install the anti-tipping hardware, when installed properly, this hardware may prevent the unit from tipping unexpectedly.

R3 x2pcs



R4 x2pcs

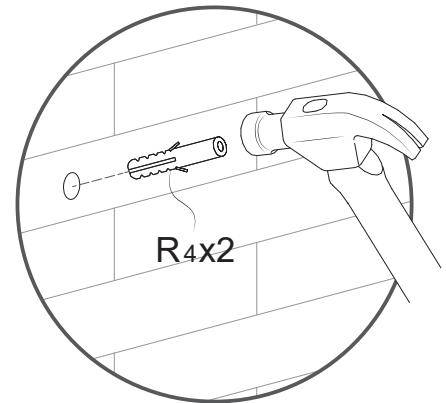
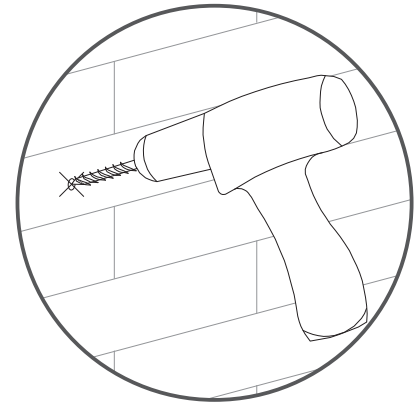
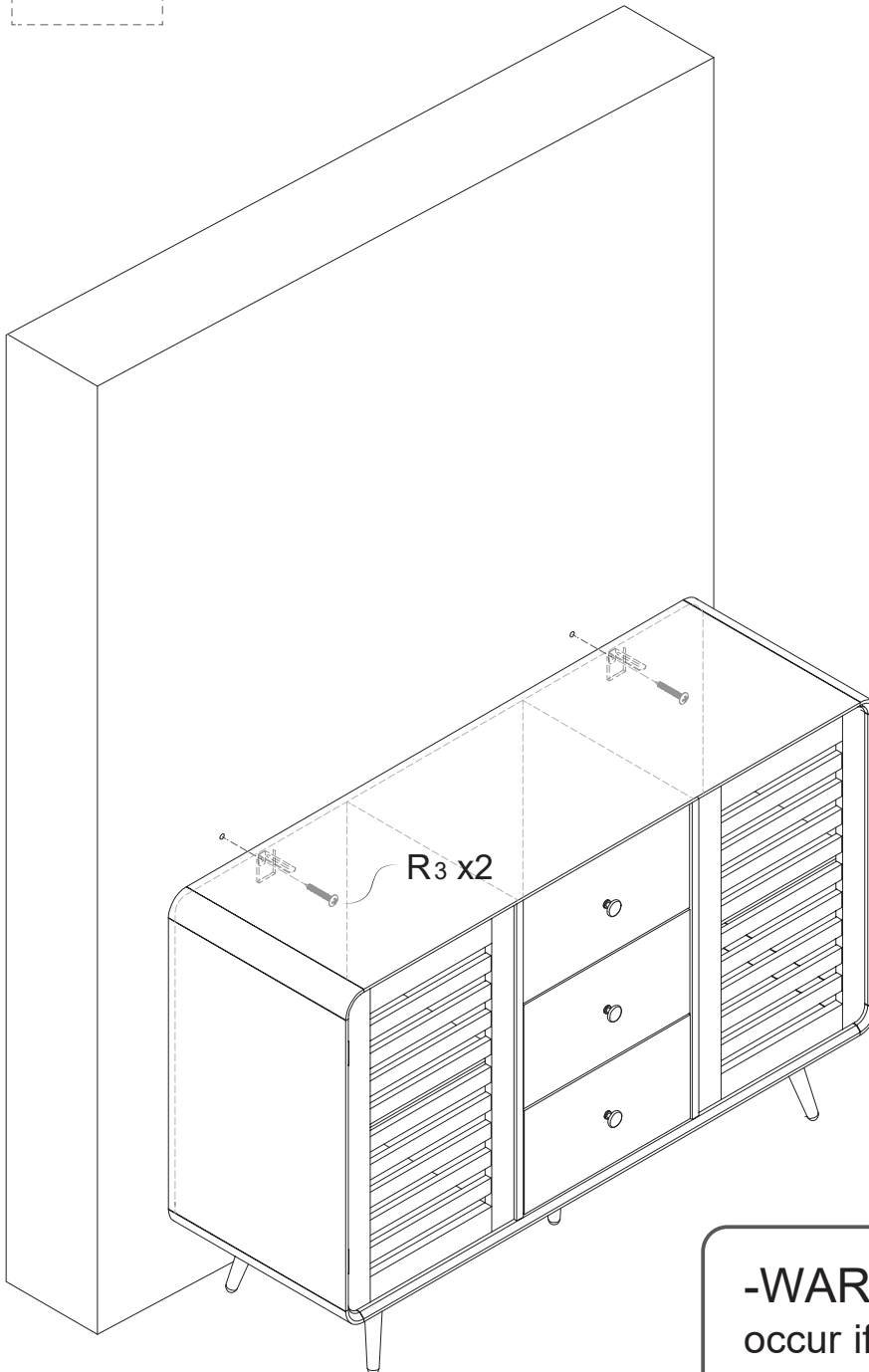

R4x2

R3 x2

**-WARNING** -Serious injury can occur if furniture tips over. Place heavy items on lower shelved and as far back as possible.