

ASSEMBLY INSTRUCTIONS

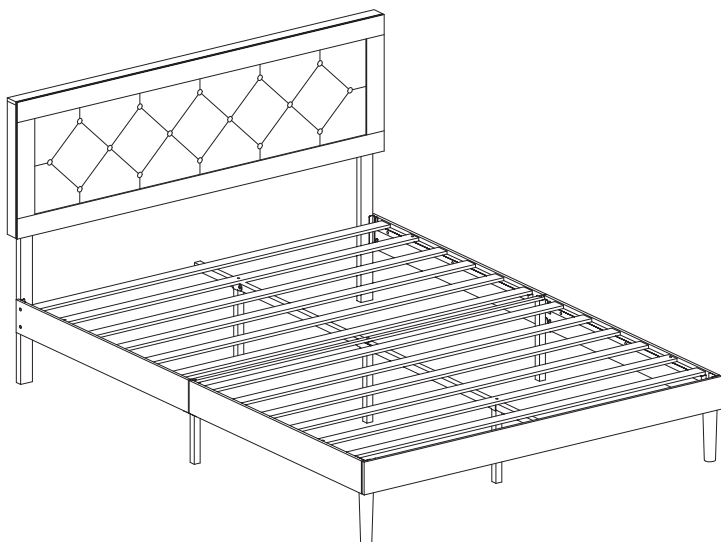

MADE IN CHINA

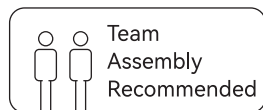

INTRODUCTION

Thank you for purchasing our product. Please read the instructions carefully before installation and keep it in a safe place for future reference. If you need any assistance or support, please feel free to contact our customer support team.

PRECAUTIONS

1. There are many components and accessories in the package. Each component and accessory is labeled with a letter or a number. Check carefully before using any of them. Keep them away from children to prevent accidents.
2. Please install the product on a clean and soft underlay (such as carpet or cardboard) to avoid scratching or damaging the surface of the product.
3. The main components of the product are relatively heavy. Please pay attention to safety during installation.
4. The product is not stable during installation. Please do not move it randomly before it is completely installed.
5. If you have any questions during installation, please contact the customer service in time.







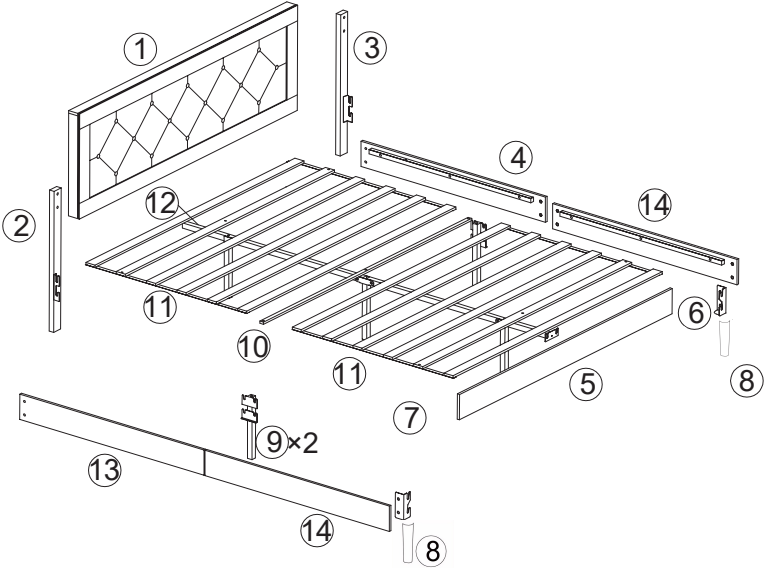

*** PLEASE BE SURE TO FOLLOW THE INSTALLATION STEPS IN THE MANUAL TO AVOID UNNECESSARY LOSSES CAUSED BY IMPROPER INSTALLATION.**

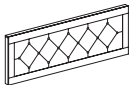
*** IF YOU NEED FURTHER ASSISTANCE, PLEASE CONTACT THE CUSTOMER SERVICE ONLINE.**

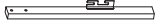
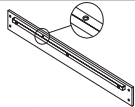
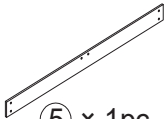



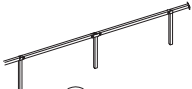
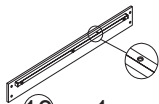
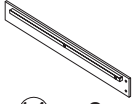

PRODUCT ASSEMBLY



PARTS LIST

 ① × 1pc	 ② × 1pc	 ③ × 1pc	 ④ × 1pc
 ⑤ × 1pc	 ⑥ × 1pcs	 ⑦ × 1pcs	 ⑧ × 2pcs
 ⑨ × 2pcs	 ⑩ × 1pc	 ⑪ × 2pcs	 ⑫ × 1pc
 ⑬ × 1pc	 ⑭ × 2pcs		

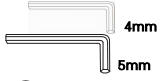
HARDWARE LIST

 M6×50mm Ⓜ₁ × 3pcs	 M8×35mm Ⓜ₁ × 6pcs + 1pc	 M8×15mm Ⓜ₂ × 2pcs	 M6×30mm Ⓜ₄ × 4pcs	 4mm 5mm Ⓜ₃ × 2pc
 M8×35mm spare parts × 1pc				

ASSEMBLY INSTRUCTIONS

3

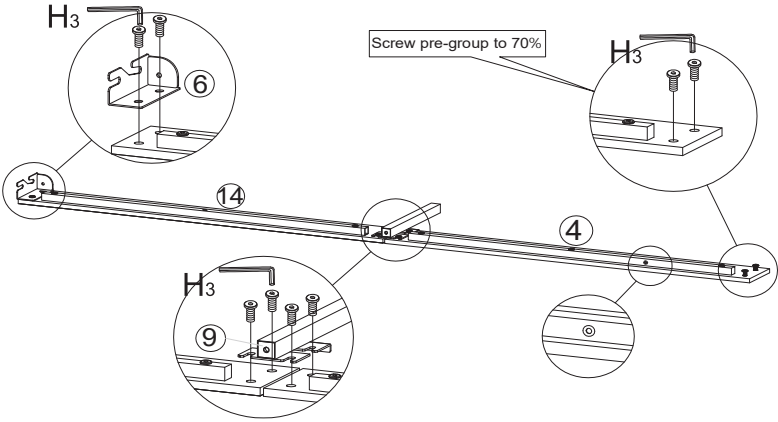

4

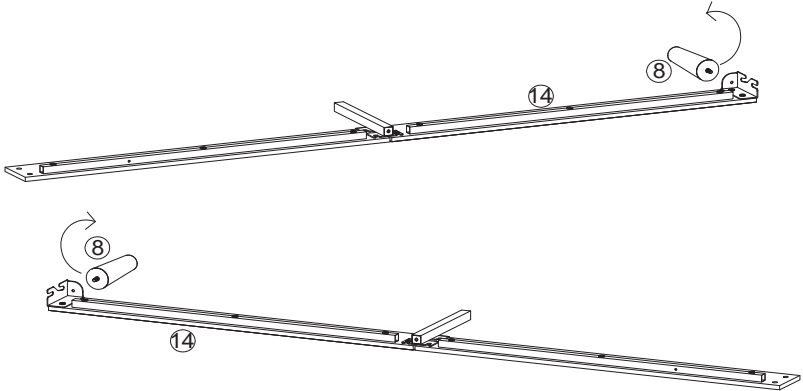

ASSEMBLY INSTRUCTIONS

5

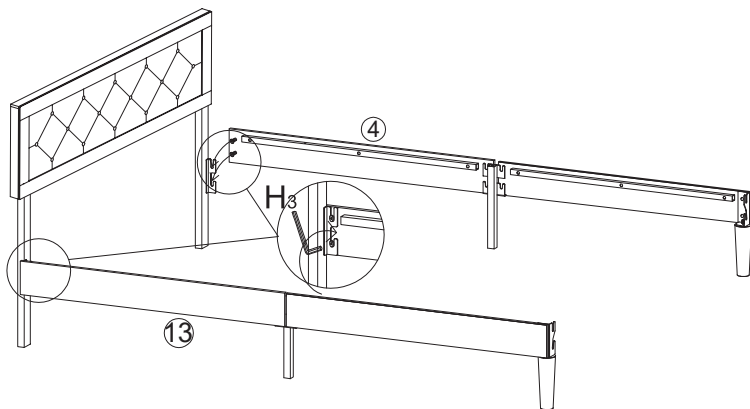

6

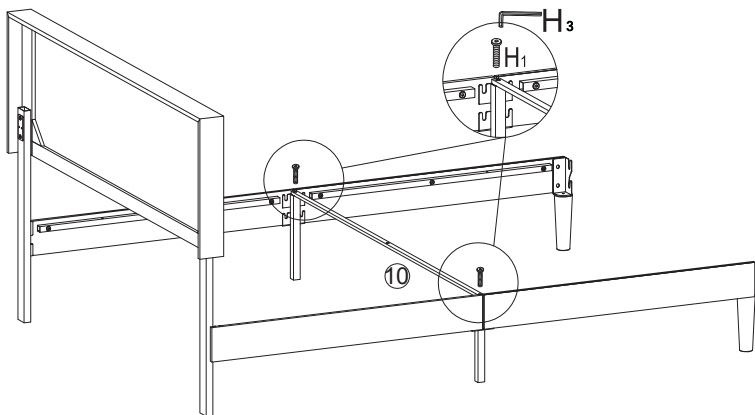

ASSEMBLY INSTRUCTIONS

7

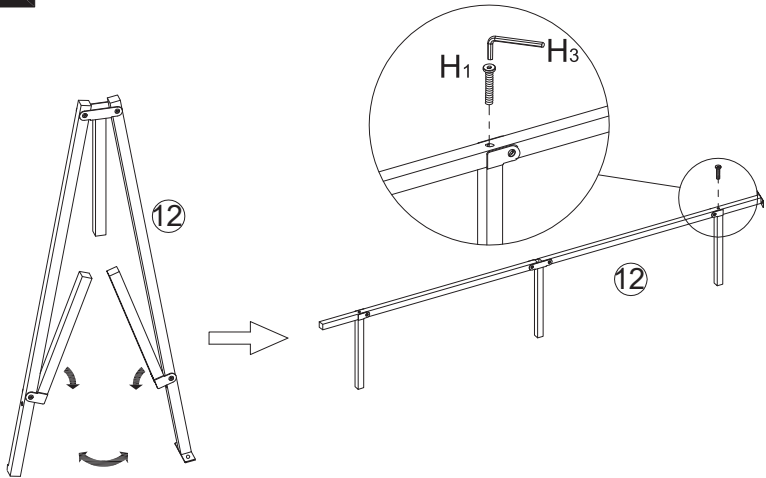

8

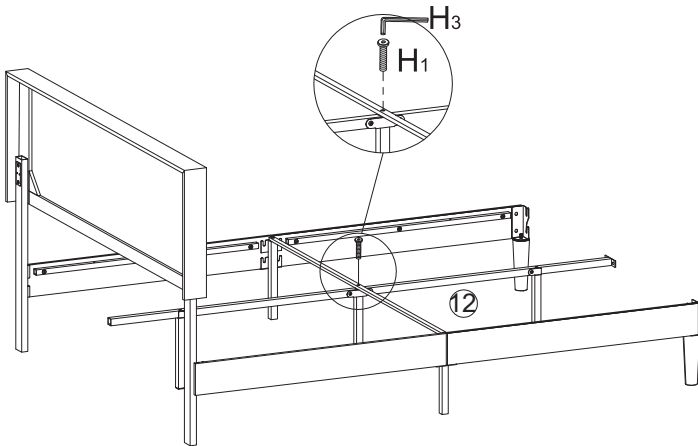

ASSEMBLY INSTRUCTIONS

9

Screw pre-group to 70%

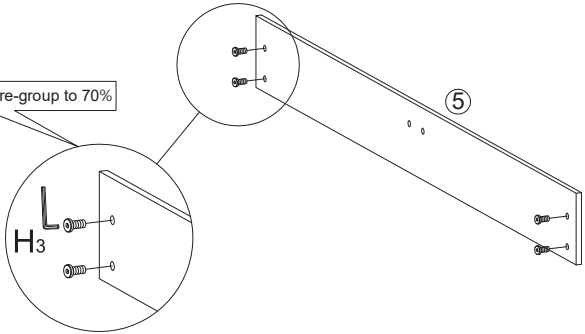

10

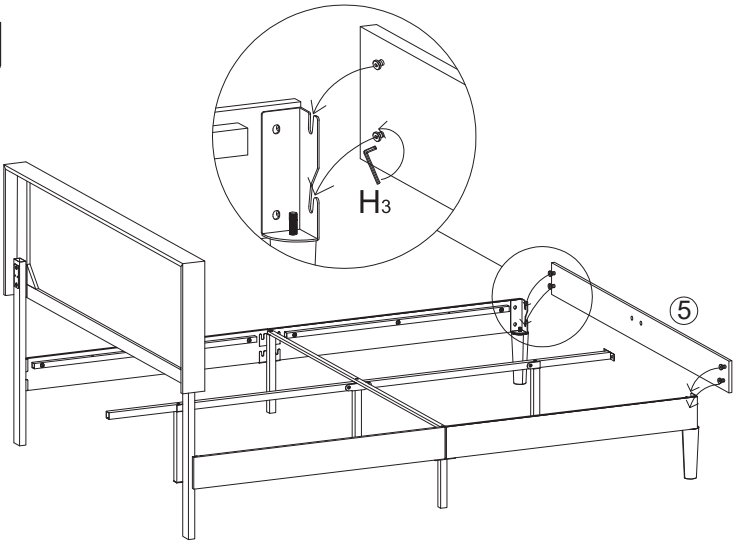

ASSEMBLY INSTRUCTIONS

11

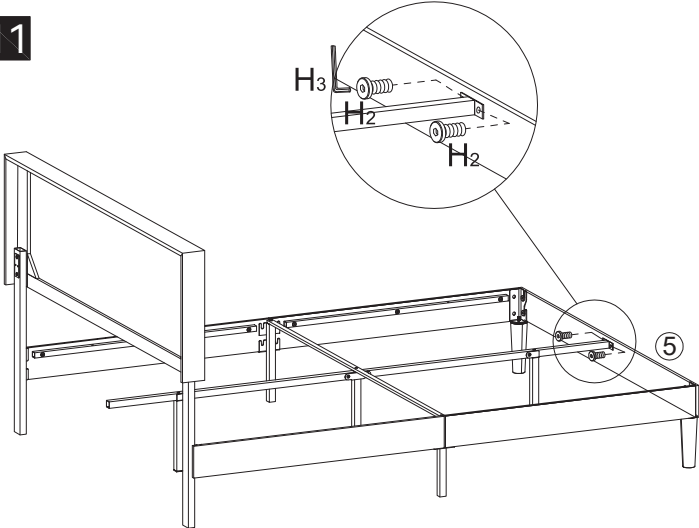

ASSEMBLY INSTRUCTIONS

12

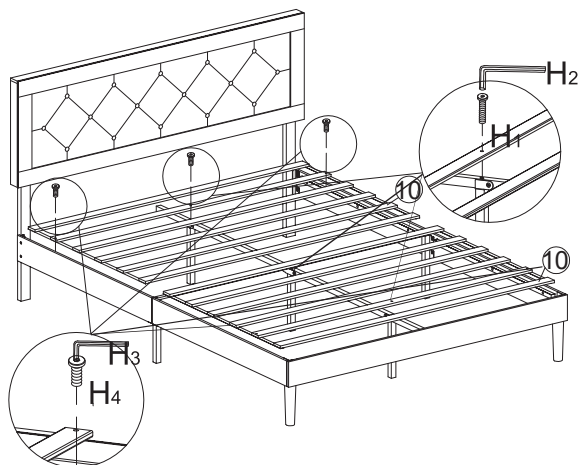

13

