

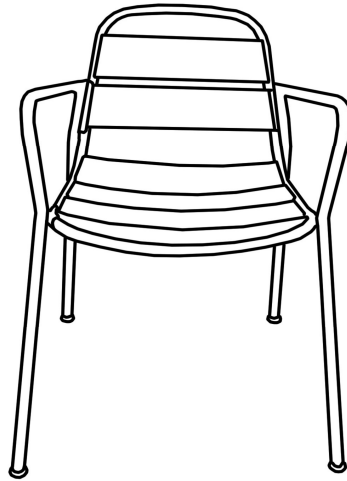

Assembly Instructions

Caution : You must read this before you proceed





Chair

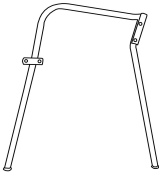
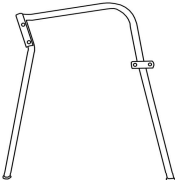

Parts List

Label	Picture	Description	QTY
A		Chair Seat	1
B		Chair Leg (Left)	1
C		Chair Leg (Right)	1

Hardware

Label	Picture	Description	QTY
①		Bolt (M6*40MM)	5
②		Bolt (M6*15MM)	5
③		Allen Key(M6)	1
④		Washer (M6)	10

Assembly Preparation

Before Beginning
Assembly:

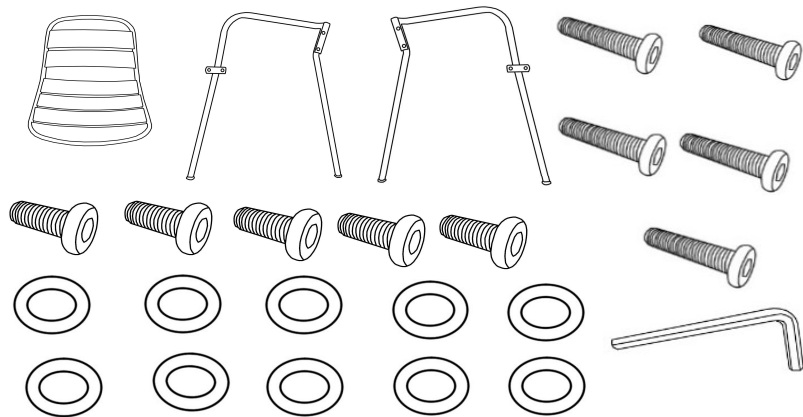

- Read instructions, cover to cover-



- Have 2 adults on hand for assembly-



- Do not assemble on flooring or carpet-



- Assemble on a clean non-marring surface (packing foam)-



- Save all packaging until finished-

Assembly Steps

Overview

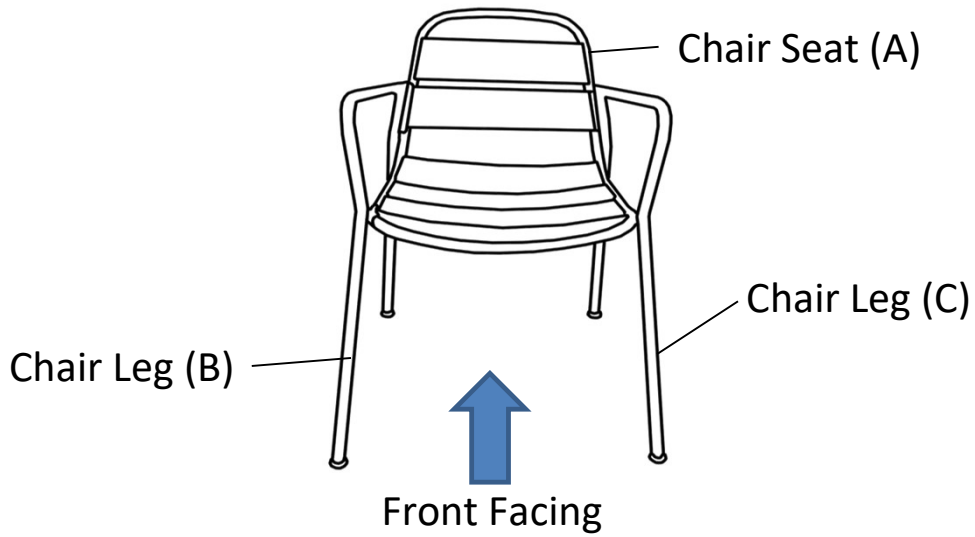

This Chair has multiple parts and may require up to 30 minutes or more to assemble. To give you an overview of the Chair, the above picture is to help you put the various parts into perspective. Please read through the instructions below to familiarise yourself with the parts and steps before assembly.

Step 1

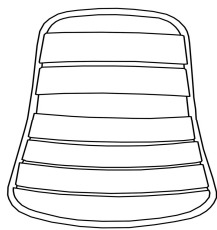

A

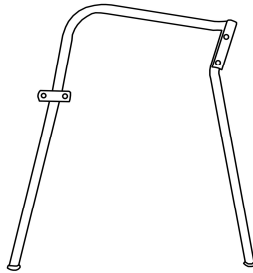

B

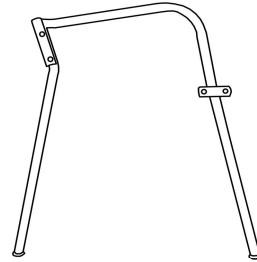

C

Unpack and place all parts on a clean, non-marring surface.

Step 2

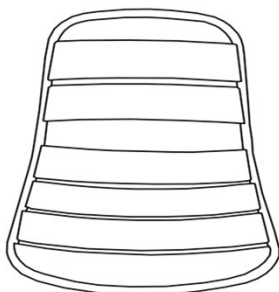

A

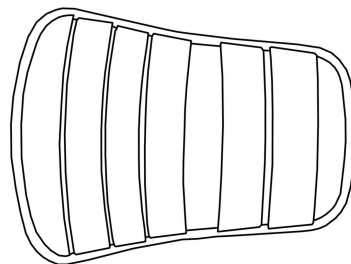

Place the Chair Seat(A) facedown as shown above.

Step 3

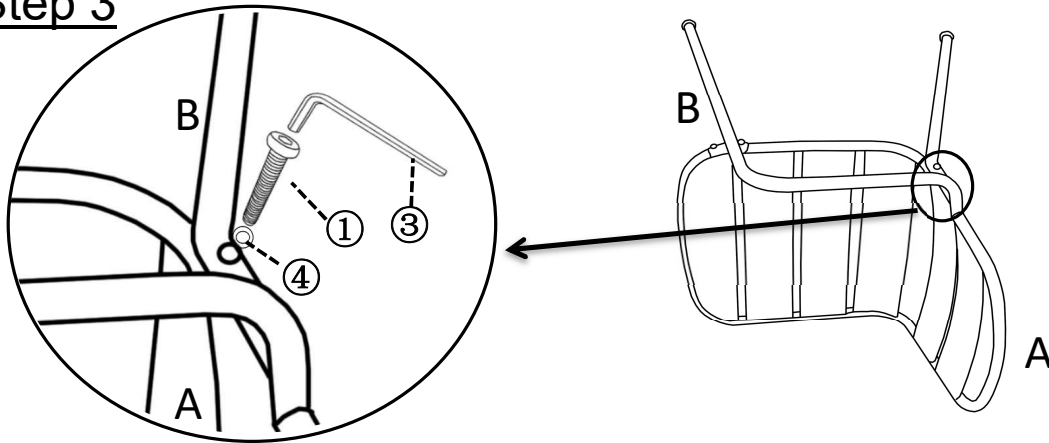

Align the mounting positions on the Chair Leg(B) and Chair Seat(A), then attach using Bolts(1) and Washers(4) with the Allen Key(3). (Here are two positions that need to be assembled)

Do not fully tighten the Bolts.

Step 4

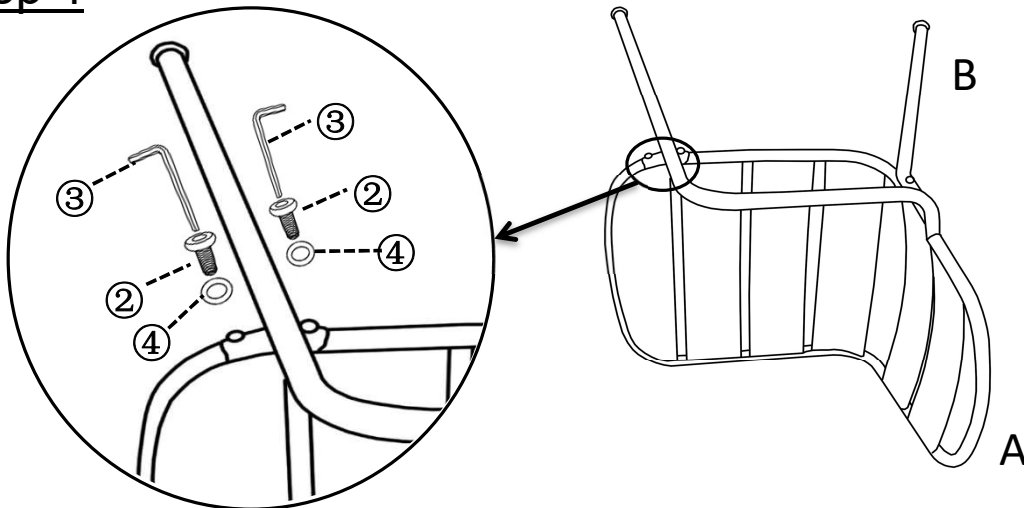

Align the mounting positions on the Chair Leg(B) and Chair Seat(A), then attach using Bolts(2) and Washers(4) with the Allen Key(3).

Do not fully tighten the Bolts.

Step 5

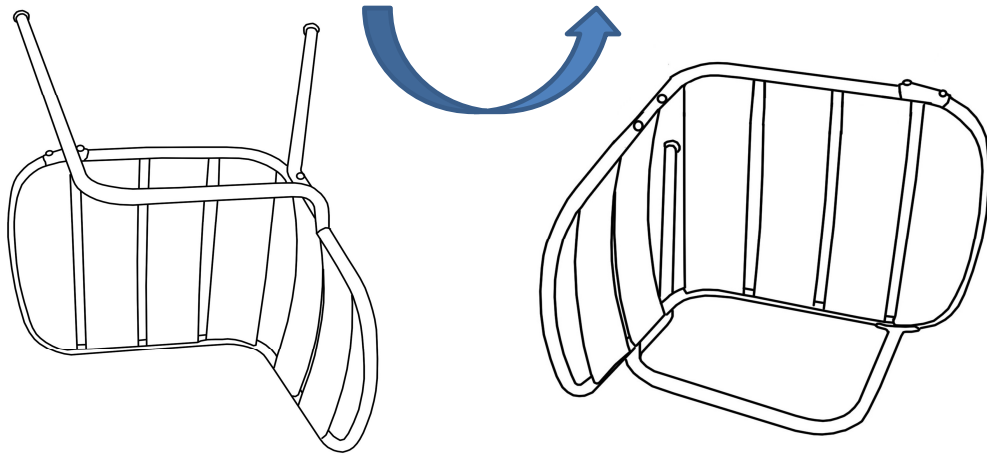

Turn the chair 's another side up as above shown

Step 6

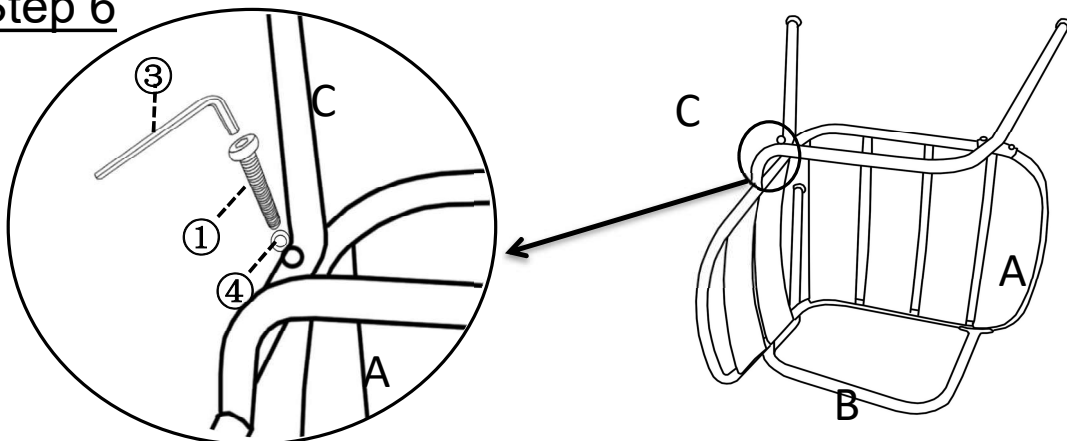

Align the mounting positions on the Chair Leg(C) and Chair Seat(A), then attach using Bolts(1) and Washers(4)with the Allen Key(3).(Here are two positions that need to be assembled)

Do not fully tighten the Bolts.

Step 7

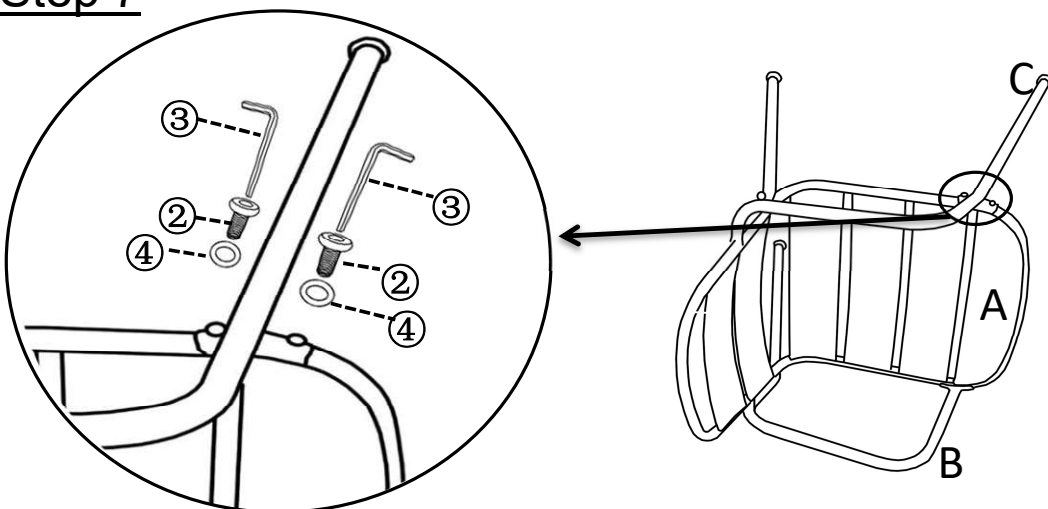

Align the mounting positions on the Chair Leg(B) and Chair Seat(A), then attach using Bolts(②) and Washers(④)with the Allen Key(③).
Tighten all Bolts.

Step 8

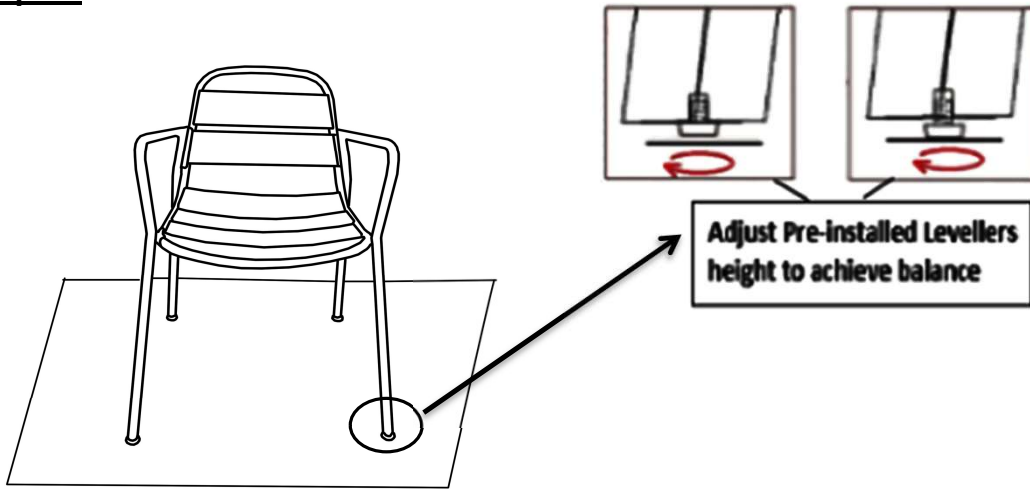

Adjust the Pre-installed Levellers at the base of the Legs until the Chair is level with the ground.



























Step 9



Your Chair is ready for use.

This Chair can only be used on a flat, level surface.

Care & Maintenance

-    Do not put hot items directly on furniture surface
 -    Do not clean furniture with harsh cleansers or polish.
 -    To obtain the longest lifespan of your outdoor products, minimizing exposure to direct sunlight is recommended.
 -    Children should not climb or jump on the furniture.
 -    Do not write on furniture without a padded barrier to protect the surface.
 -    To obtain the longest lifespan of your outdoor products, avoid extended and lengthy exposure to rain, snow, and direct sunshine. Whenever possible cover the product and /or place under patio or awnings.
 -    Not for commercial use. For residential use only .
 -    Stains may be removed with mild soap solution and damp cloth.
-
-    Dust and pick-up spills using a clean, non-colored, lint-free cloth .

Assembly Instructions

Caution : You must read this before you proceed

Table

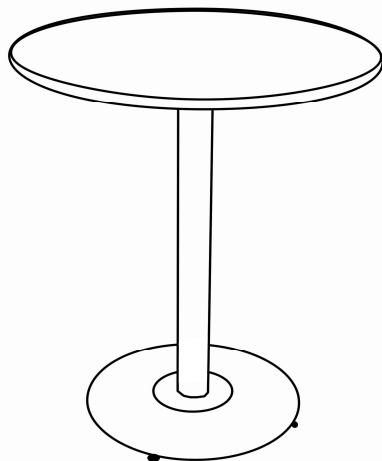

Parts List

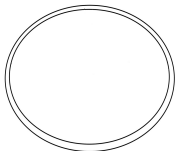
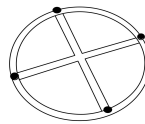
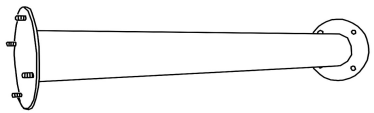
Label	Picture	Description	QTY
D		Table Top	1
E		Table Base	1
F		Support Ring	1

Hardware

Label	Picture	Description	QTY
⑤		Washer(M8)	5
⑥		Nut(M8)	5
⑦		Spanner wrench(M8)	1
⑧		Bolt(M8*15mm)	5
⑨		Allen Key(M8)	1

Assembly Preparation

Before Beginning Assembly:

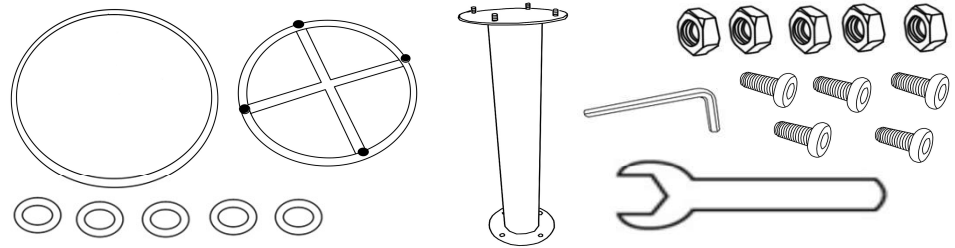

- Read instructions, cover to cover-



- Have 2 adults on hand for assembly-



- Do not assemble on flooring or carpet-



- Assemble on a clean non-marring surface (packing foam)-



- Save all packaging until finished-

Assembly Steps

Overview

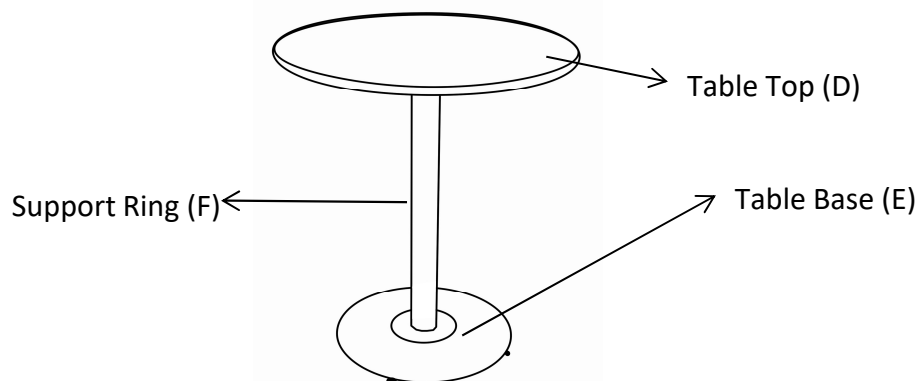

This Table has multiple parts and may require up to 20 minutes to assemble. To give you an overview of the Table parts, the above picture is to help you put the various parts into perspective. Please read through the instructions below to familiarise yourself with the parts and steps before assembly.

Step 1

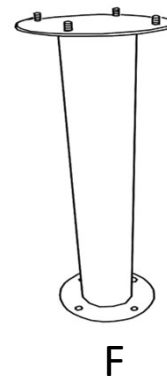
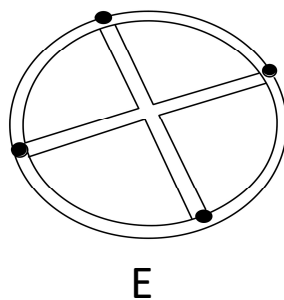
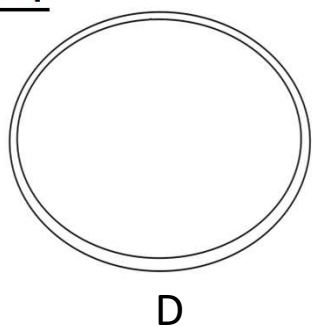

Unpack and place all parts on a clean, non-marring surface.

Step 2

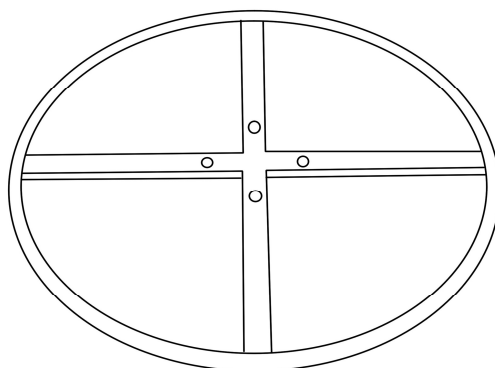
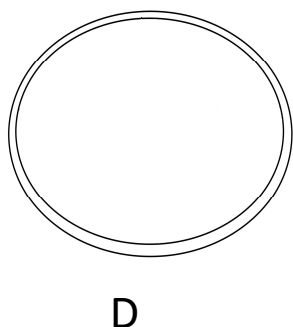

Lay the Table Top (D) facedown onto a clean, non-marring surface.

Step 3

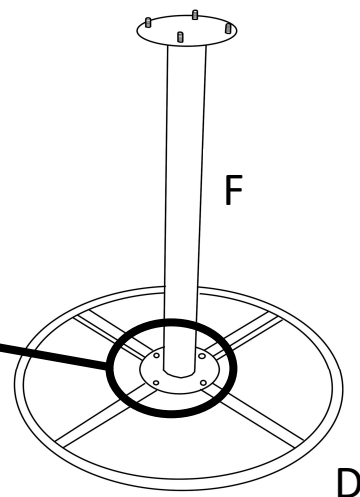
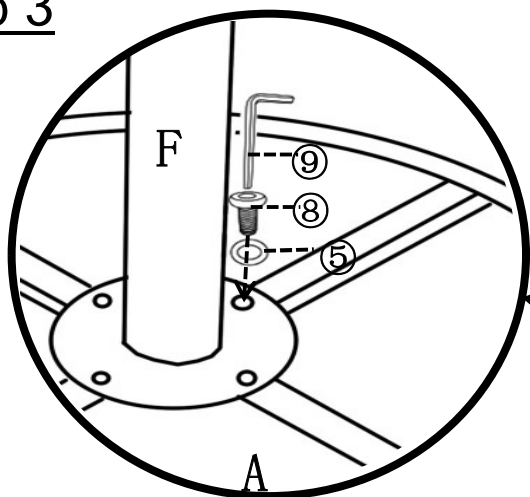

Attach the Support Ring (F) to the Table Top (D) using Bolts (8) and Washers (5) with the Allen Key (9).

Do not fully tighten the Bolts.

Step 4

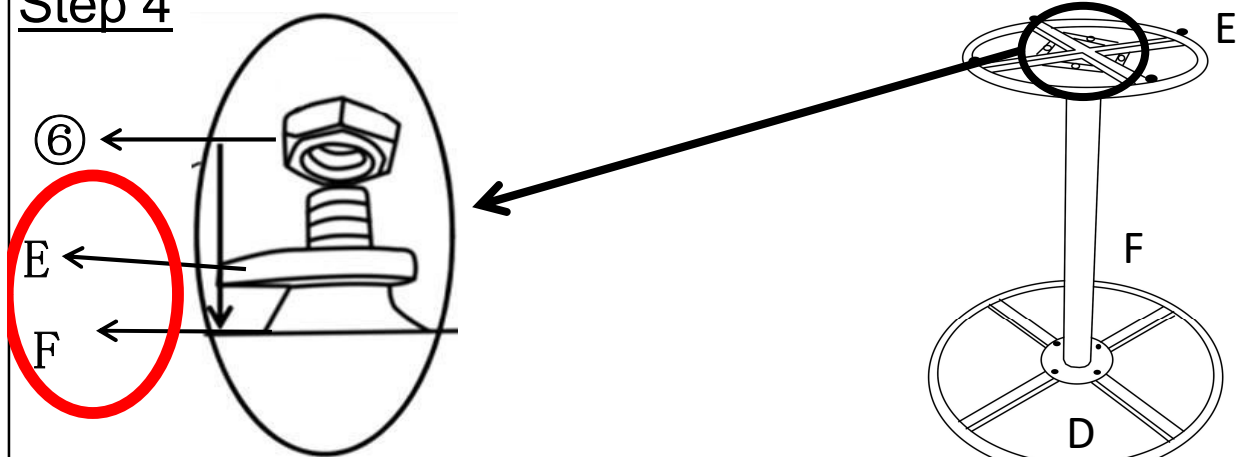

Attach the Support Ring(F) to the Table Base(E) using Nuts(6) with the Spanner wrench(7).
Tighten all Nuts at all joints in a sequential manner.

Step 5

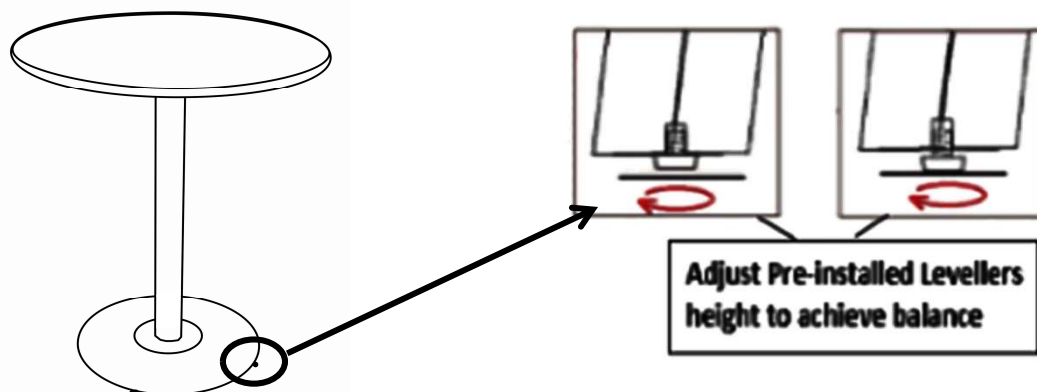





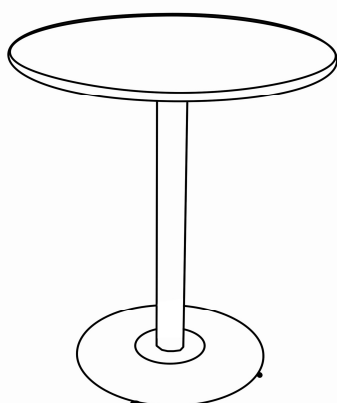













Stand the Table up.
Adjust the Pre-installed Levellers at the bottom of the Table Base until the Table is level with the ground.

Step 6



Your Table is ready for use.
This Table can only be used on a flat, level surface.

Care & Maintenance

-   ● Do not put hot items directly on furniture surface
 -   ● Do not clean furniture with harsh cleansers or polish.
 -   ● To obtain the longest lifespan of your outdoor products, minimizing exposure to direct sunlight is recommended.
 -   ● Children should not climb or jump on the furniture.
 -   ● Do not write on furniture without a padded barrier to protect the surface.
 -   ● To obtain the longest lifespan of your outdoor products, avoid extended and lengthy exposure to rain, snow, and direct sunshine. Whenever possible cover the product and /or place under patio or awnings.
 -   ● Not for commercial use. For residential use only .
 -   ● Stains may be removed with mild soap solution and damp cloth.
-
-   ● Dust and pick-up spills using a clean, non-colored, lint-free cloth .