

Assembly Instructions

BED137CQ

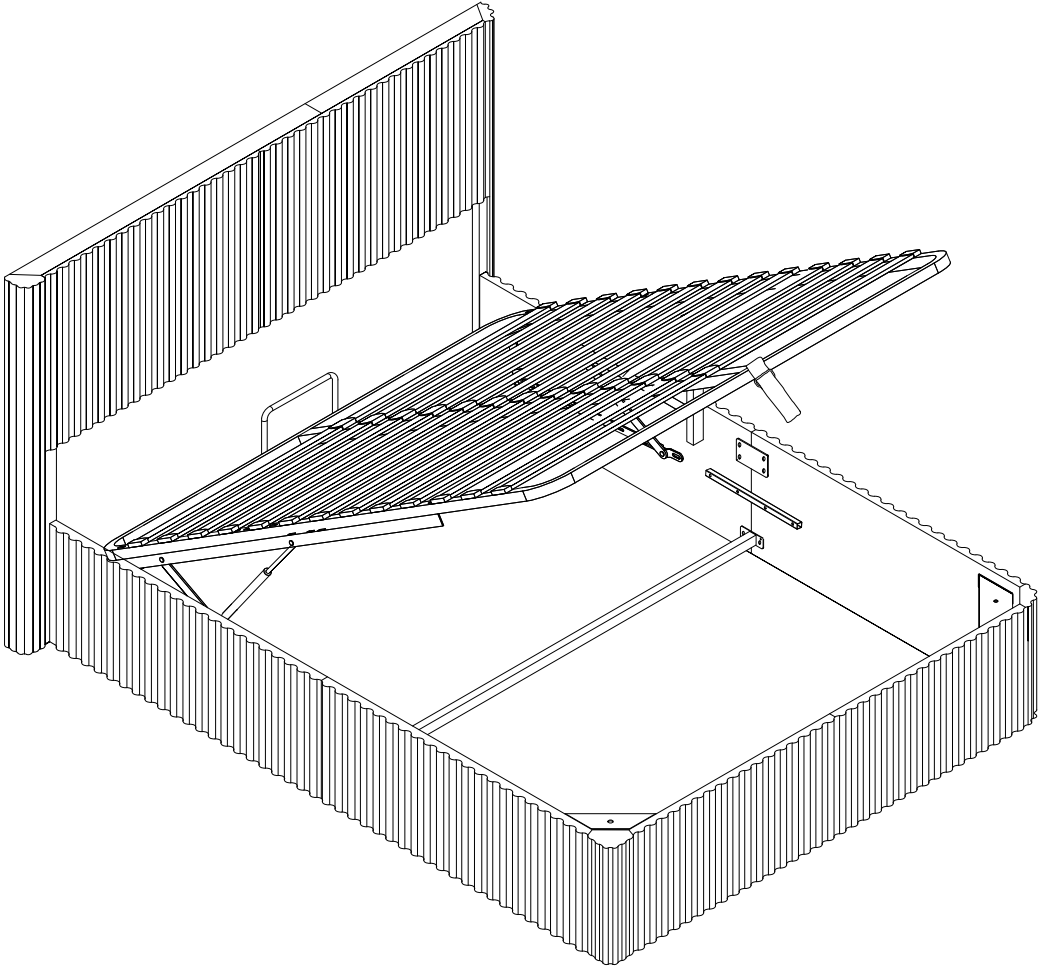

General Guidelines

- Please read the following instruction carefully and use the product accordingly.
- Please keep this manual and hand it over when you transfer the product.
- This summary may not include every detail of all variations and considered steps. Please contact us when further information and help are needed.

Notes

- The product is intended for indoor use only. The product must be assembled and used in accordance with the provisions of the manual. Personal injury and/or damage to product may occur if products are used outside of their intended purposes and/or if products have been changed/modified from their original design. The seller does not assume any responsibility or liability with respect to any injury/damage caused by incorrect assembly or improper use.
- Avoid long-term exposure to humid environments to prevent mildew.
- Keep the product away from fire sources and high temperatures. Do not expose the product to direct sunlight.
- Do not place any hot objects on the surface of the product.
- If there are any defective or missing parts after unpacking, please cease assembly immediately and contact us.
- Please assemble the item on a spacious surface and do not place the unwrapped product directly on the ground to avoid product damage.
- Please do not stand or sit on the wooden boards.
- Please wear gloves during the assembly and/or disassembly process to avoid scratches from any sharp edges.
- Please match the corresponding part and fitting based on the part number in the manual.
- If the part does not match with the fitting, please check the piece as specified in this manual.
- During assembly, first loosely align all screws with the corresponding pre-drilled holes and then tighten the screws one by one.
- Periodically inspect screw tightness while the product is in use. If necessary, retighten to ensure structural integrity.
- If you accidentally spill water or another liquid on the surface, immediately wipe clean with a dry towel.
- Please keep the product away from sharp, pointed objects and corrosive substances to prevent product damage.
- Please place this item on level, solid ground during use.



Warnings

- During assembly, keep all small parts out of the reach of children. It may be fatal if swallowed or inhaled.
- Children should not climb or play on the product in order to avoid tipping over the furniture and causing serious injury.
- To avoid the potential dangers of suffocation, please keep all parts and packaging (film, plastic bags, foam, etc.) away from babies and children.
- Keep sharp objects and corrosive items away from the product to avoid any damage or injury.
- Do not shake or move violently during use to avoid tipping over the product.

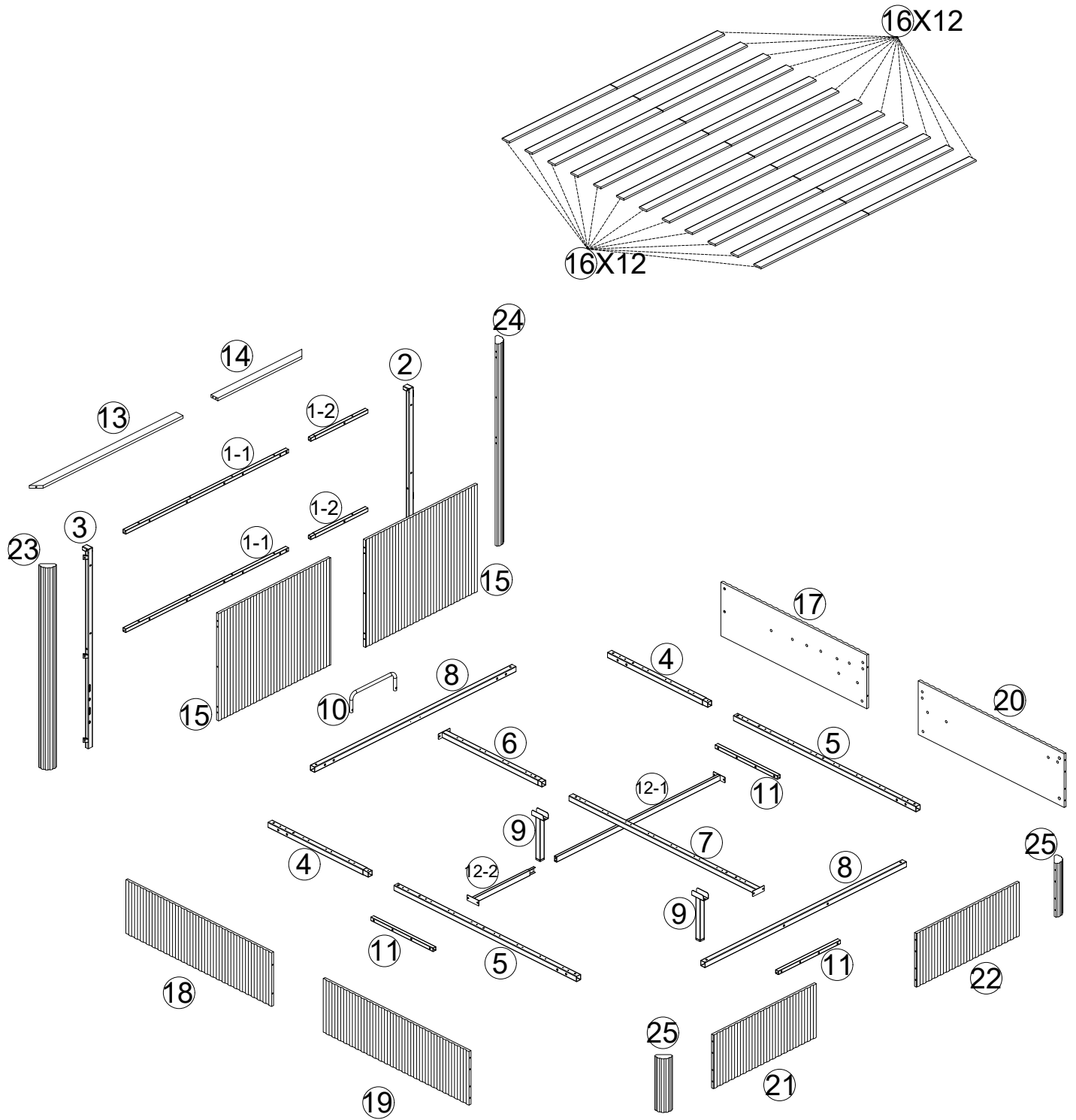
Parts List (EN)



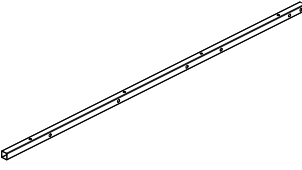
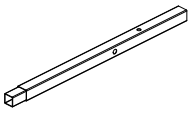

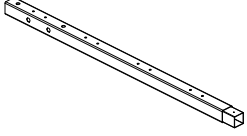
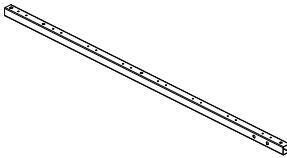
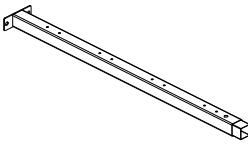
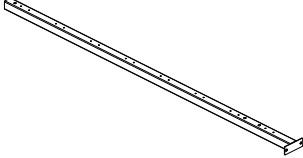
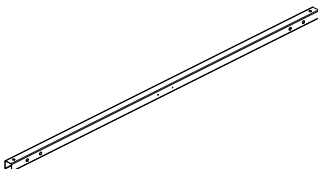
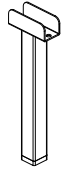
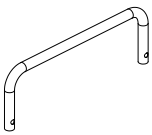
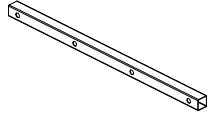
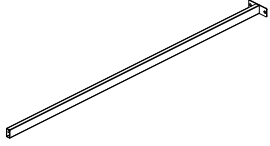
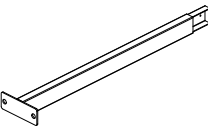
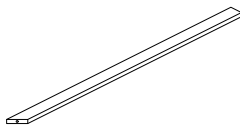
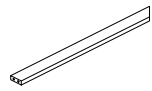
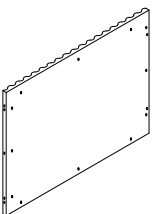
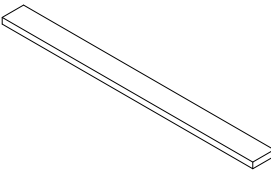
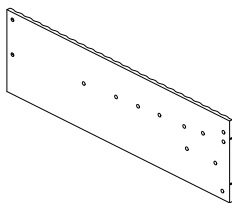
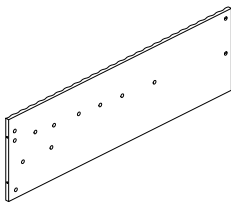
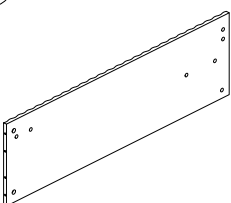
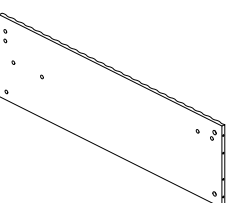
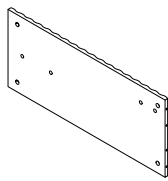
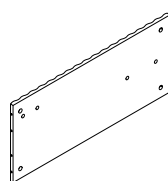

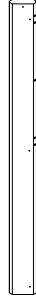
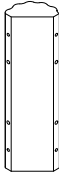

Parts List (EN)

<p>①-1</p>  <p>2PCS</p>	<p>①-2</p>  <p>2PCS</p>	<p>②</p>  <p>1PC</p>	<p>③</p>  <p>1PC</p>
<p>④</p>  <p>2PCS</p>	<p>⑤</p>  <p>2PCS</p>	<p>⑥</p>  <p>1PC</p>	<p>⑦</p>  <p>1PC</p>
<p>⑧</p>  <p>2PCS</p>	<p>⑨</p>  <p>2PCS</p>	<p>⑩</p>  <p>1PC</p>	<p>⑪</p>  <p>3PCS</p>
<p>⑫-1</p>  <p>1PC</p>	<p>⑫-2</p>  <p>1PC</p>	<p>⑬</p>  <p>1PC</p>	<p>⑭</p>  <p>1PC</p>
<p>⑮</p>  <p>2PCS</p>	<p>⑯</p>  <p>24PCS</p>	<p>⑰</p>  <p>1PC</p>	<p>⑱</p>  <p>1PC</p>
<p>⑲</p>  <p>1PC</p>	<p>⑳</p>  <p>1PC</p>	<p>㉑</p>  <p>1PC</p>	<p>㉒</p>  <p>1PC</p>

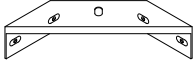

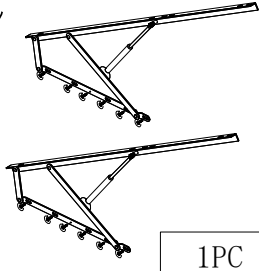

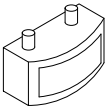
Parts List (EN)

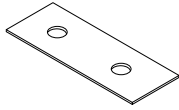
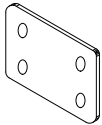
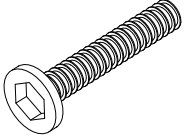
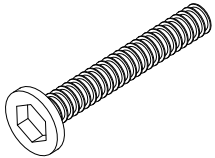
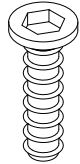
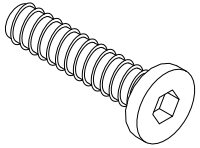
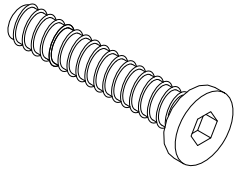
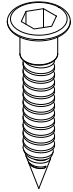
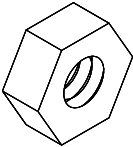
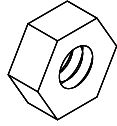
<p>23</p>  <p>1PC</p>	<p>24</p>  <p>1PC</p>	<p>25</p>  <p>2PCS</p>	
--	--	--	--

Hardware list (EN)

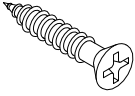
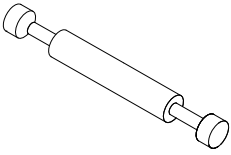
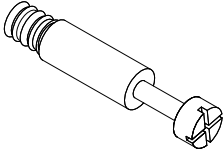
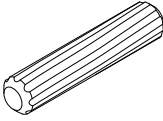
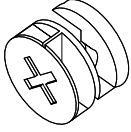
<p>A</p>  <p>6PCS</p>	<p>B</p>  <p>4PCS</p>	<p>C</p>  <p>1PC</p>	<p>D</p>  <p>12+1PC</p>
<p>E</p>  <p>24+2PCS</p>	<p>F</p>  <p>1PC</p>	<p>G</p>  <p>1PC</p>	<p>H</p>  <p>2PCS</p>
<p>I</p>  <p>M8*40 6+1PC</p>	<p>J</p>  <p>M8*50 5+1PC</p>	<p>K</p>  <p>M6*12 66+4PCS</p>	<p>L</p>  <p>M6*28 30+2PCS</p>
<p>M</p>  <p>M6*45 8+1PC</p>	<p>N</p>  <p>ST5*30 7+1PC</p>	<p>O</p>  <p>M8 6+1PC</p>	<p>P</p>  <p>M6 4+1PC</p>

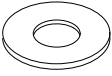
Hardware list (EN)

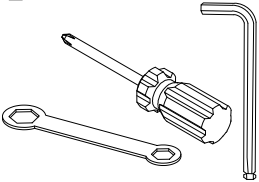
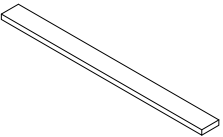
<p>Q</p>  <p>3.5*14</p> <p>6+1PC</p>	<p>R</p>  <p>∅6*80</p> <p>5+1PC</p>	<p>S</p>  <p>∅6*40</p> <p>14+1PC</p>	<p>T</p>  <p>∅6*30</p> <p>22+2PCS</p>
<p>U</p>  <p>∅15*9.5</p> <p>24+2PCS</p>	<p>V</p>  <p>M8*12.5</p> <p>4+1PC</p>	<p>W</p>  <p>10*19</p> <p>28+2PCS</p>	<p>X</p>  <p>M8</p> <p>2PCS</p>
<p>Y</p>  <p>1PC</p>	<p>Z</p>  <p>10*70</p> <p>12+2PCS</p>		

Installation suggestion: 1-2 people



Note: The nut of the air pressure rod is in a removed state. If the air pressure rod fails to press in place after being pressed down, please slightly lift the bed and press again to exhaust the air inside the rod. Only then can it be pressed in place normally

STEP 1

Note: The side with the screws is on the outside.

Note: The side with the screws is on the outside.

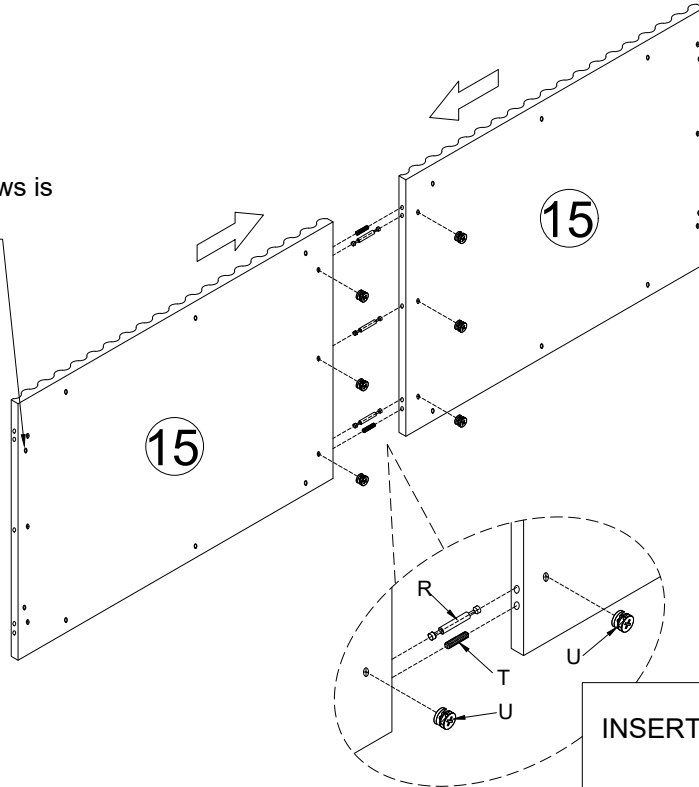

! Align the arrow on the Cam-lock to the Cam-bolt head and insert the Cam-lock. Ensure Cam-lock is fully inserted.

	R×3PCS
	T×2PCS
	U×6PCS

WARNING!!! After locking Component U in place, Component R may shift sideways. If such shifting occurs and the component cannot be locked, make adjustments accordingly.

INSERTING AND TIGHTENING CAM-BOLT

Insert Cam-lock with arrow align to Cam-bolt head

CORRECT **WRONG**

STEP 2

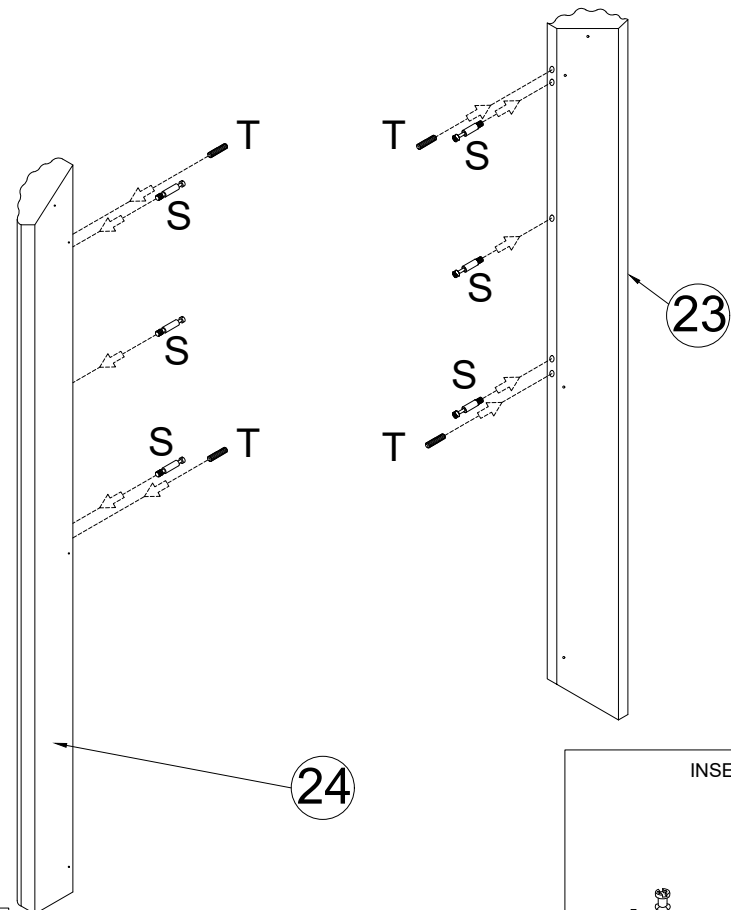

	S×6PCS
	T×4PCS

INSERTING AND TIGHTENING CAM-BOLT

Place Cam-bolt on pre-drilled hole and screw in vertically

Shoulder is flushed (on the same level) with the panel.

Shoulder is above the panel.

STEP 3



Align the arrow on the Cam-lock to the Cam-bolt head and insert the Cam-lock. Ensure Cam-lock is fully inserted.

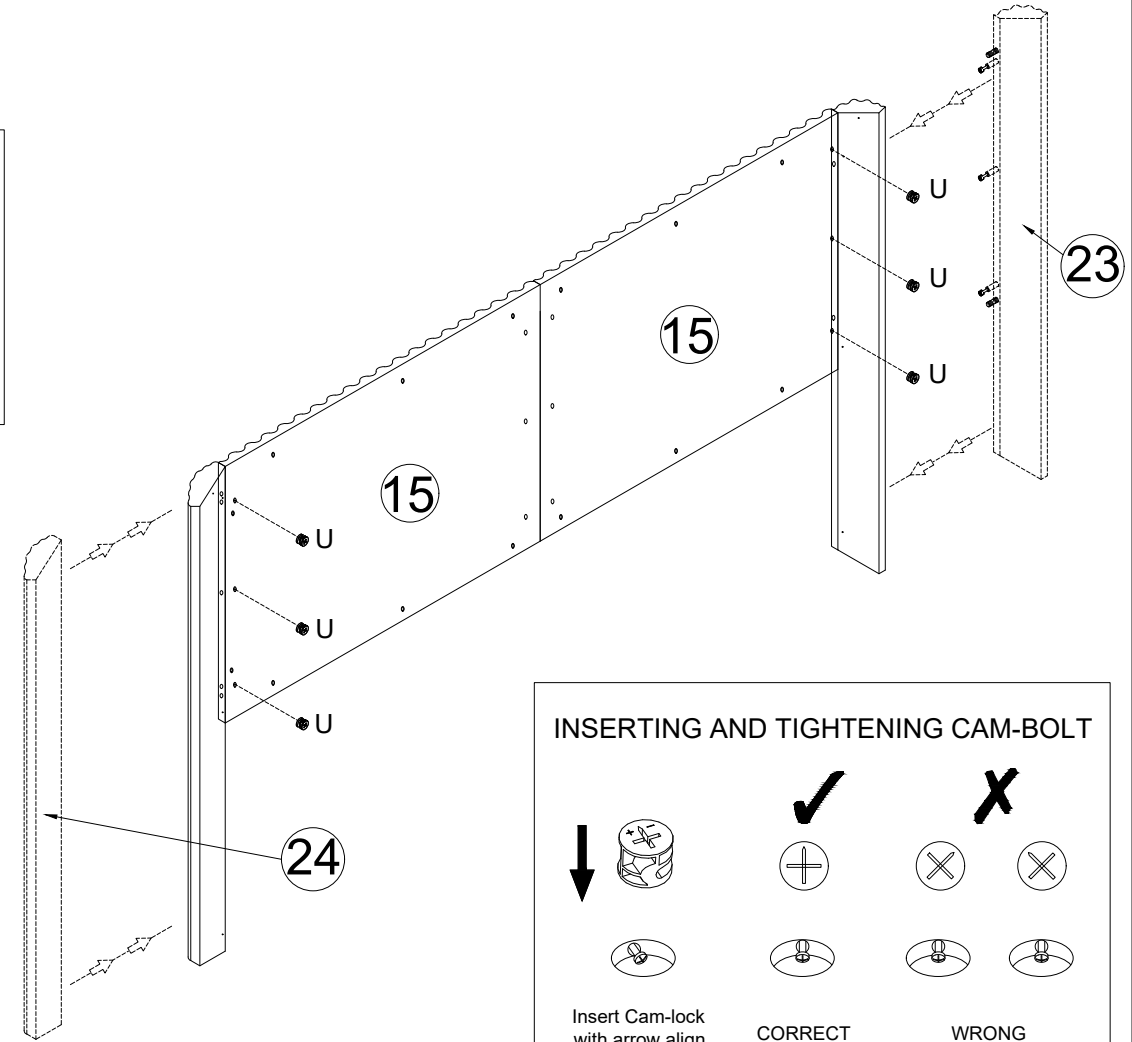

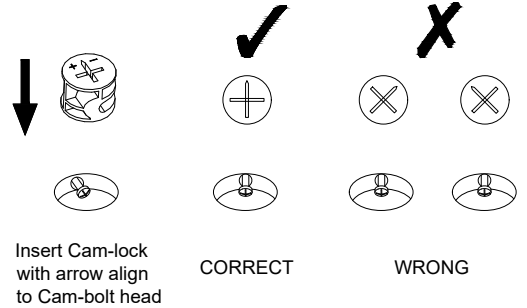

INSERTING AND TIGHTENING CAM-BOLT



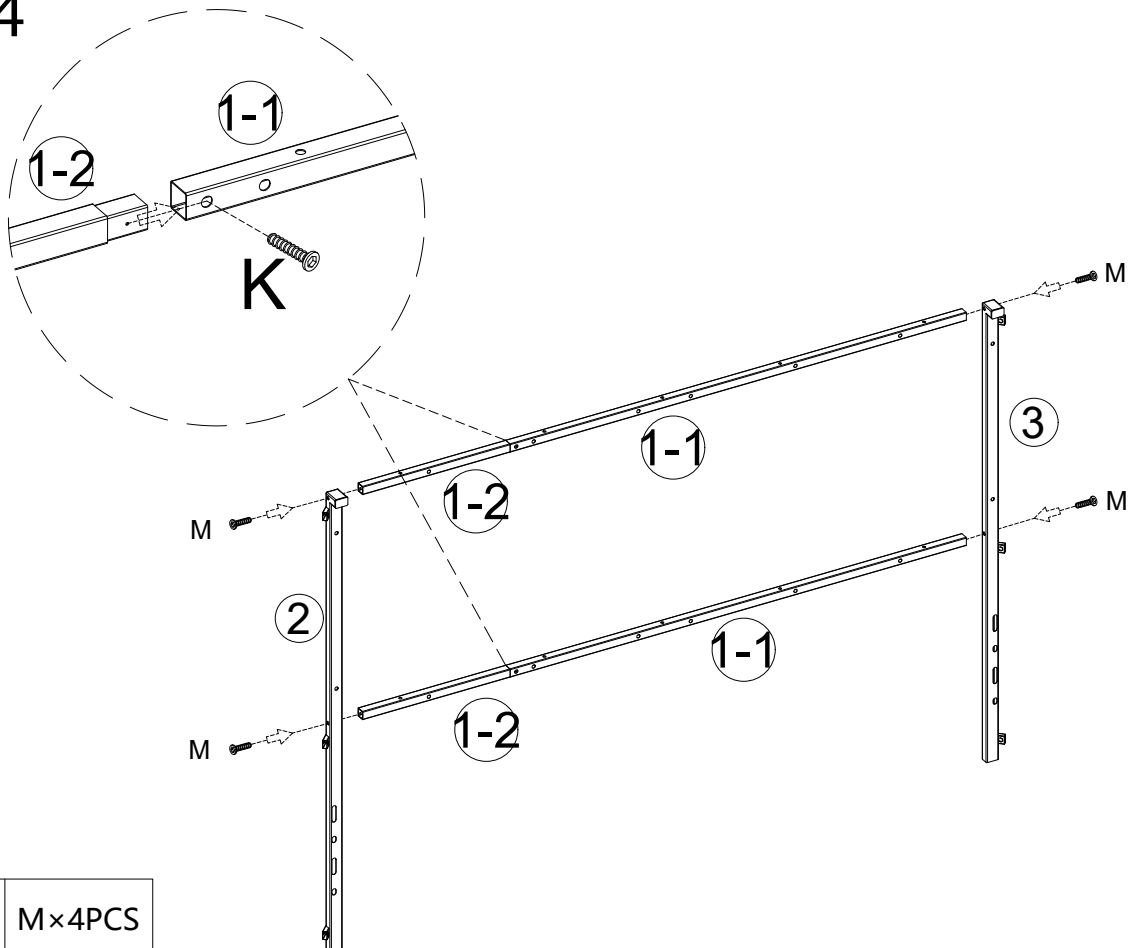

STEP 4

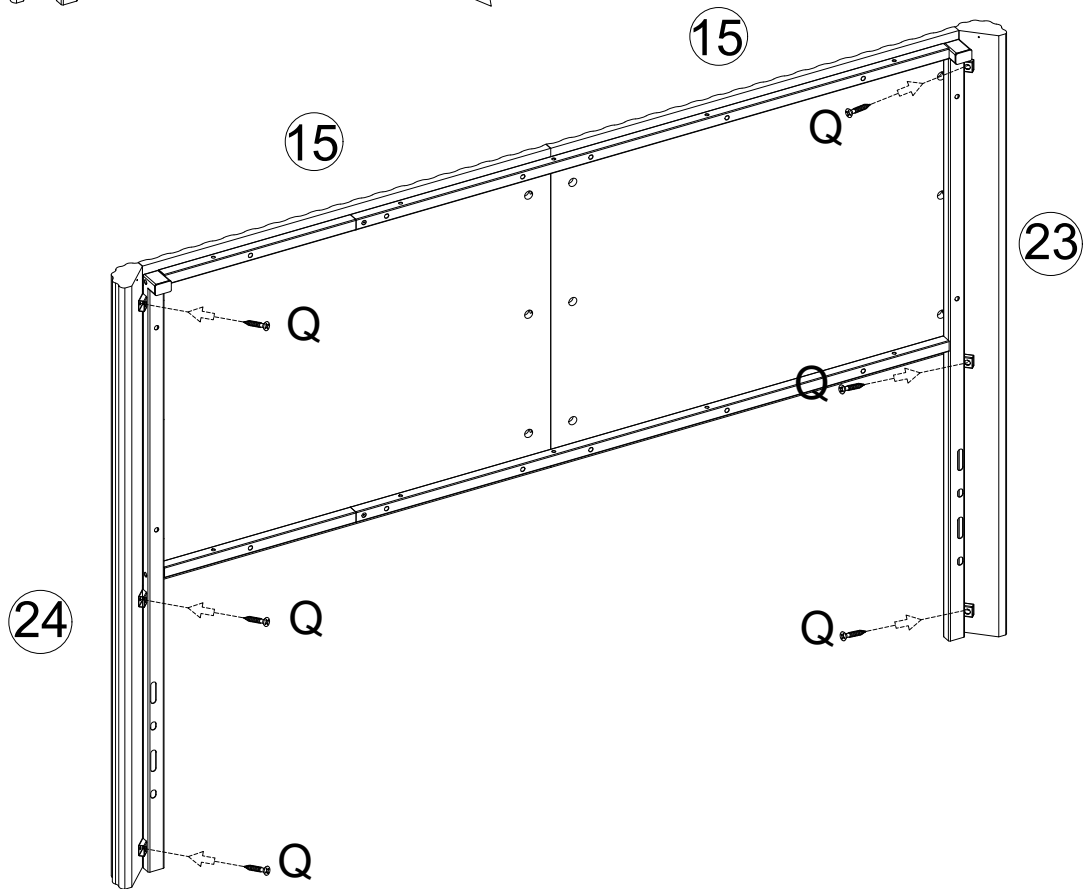
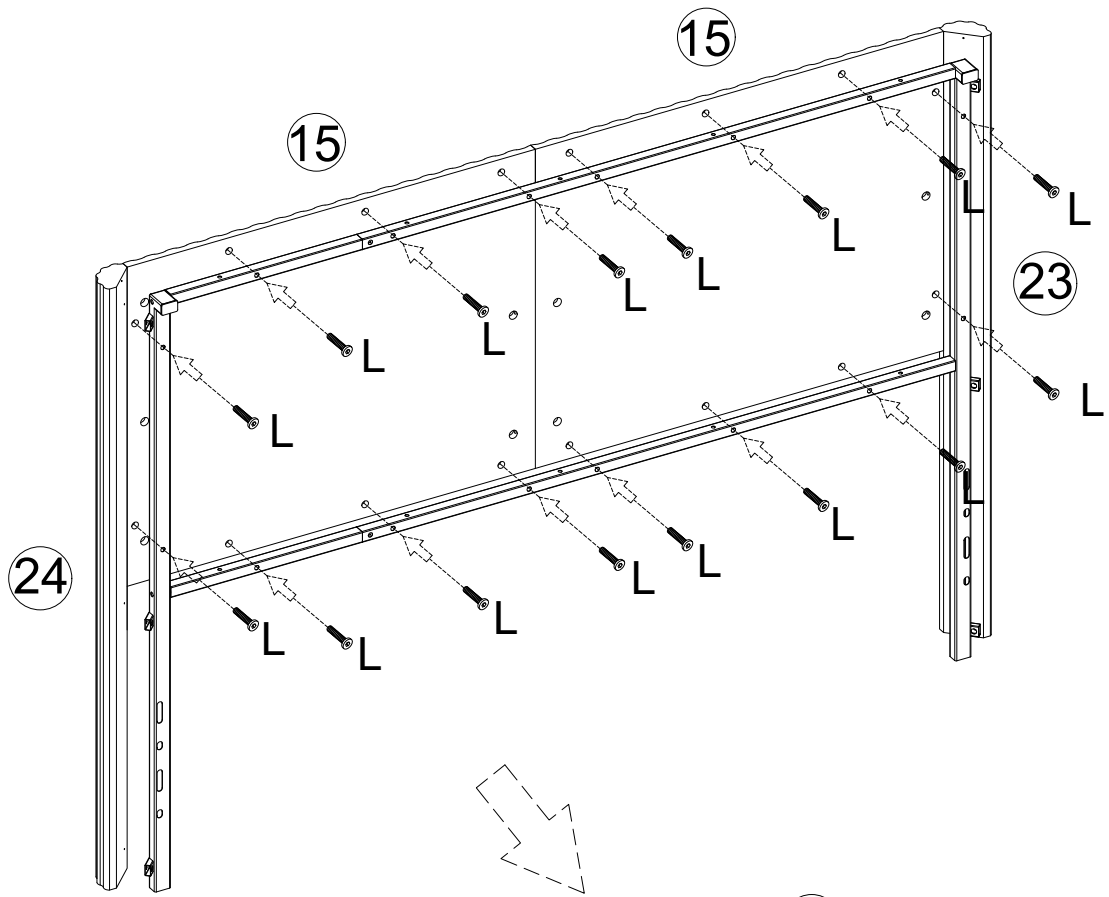

	M6X45	M×4PCS
	M6X12	K×2PCS

STEP 5



 M6X28	L×16PCS
 3.5*14	Q×6PCS

STEP 6

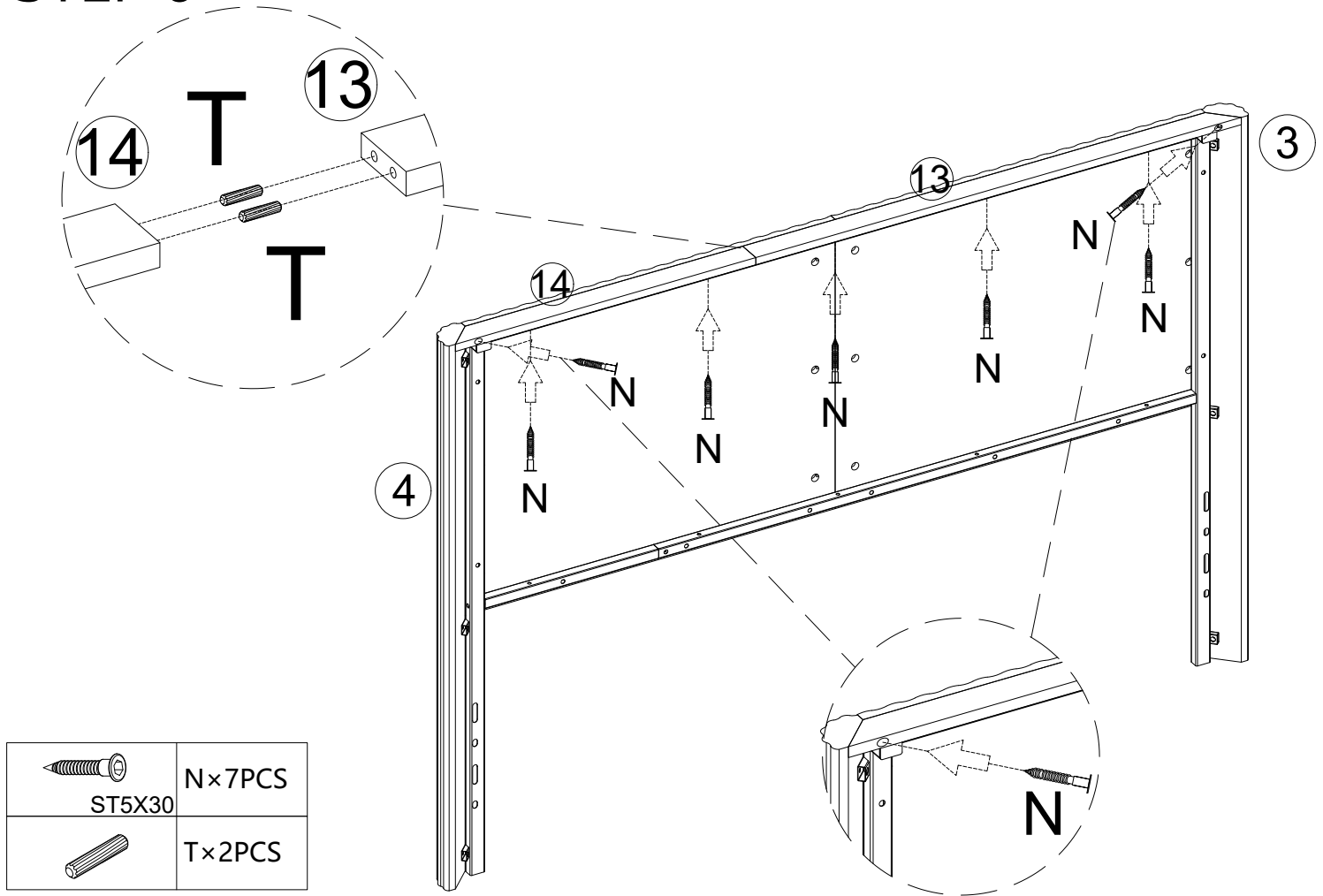

STEP 7

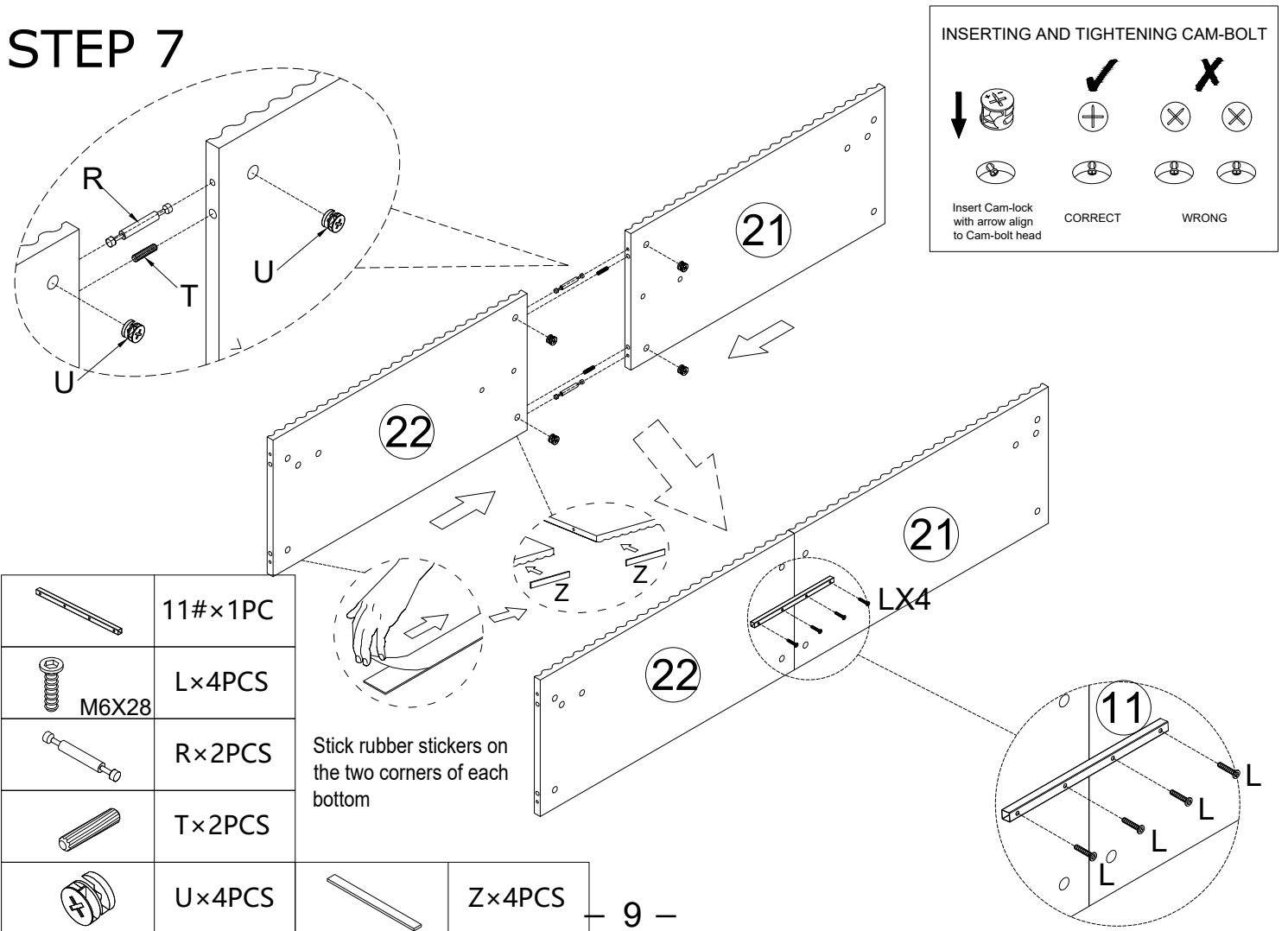

STEP 8

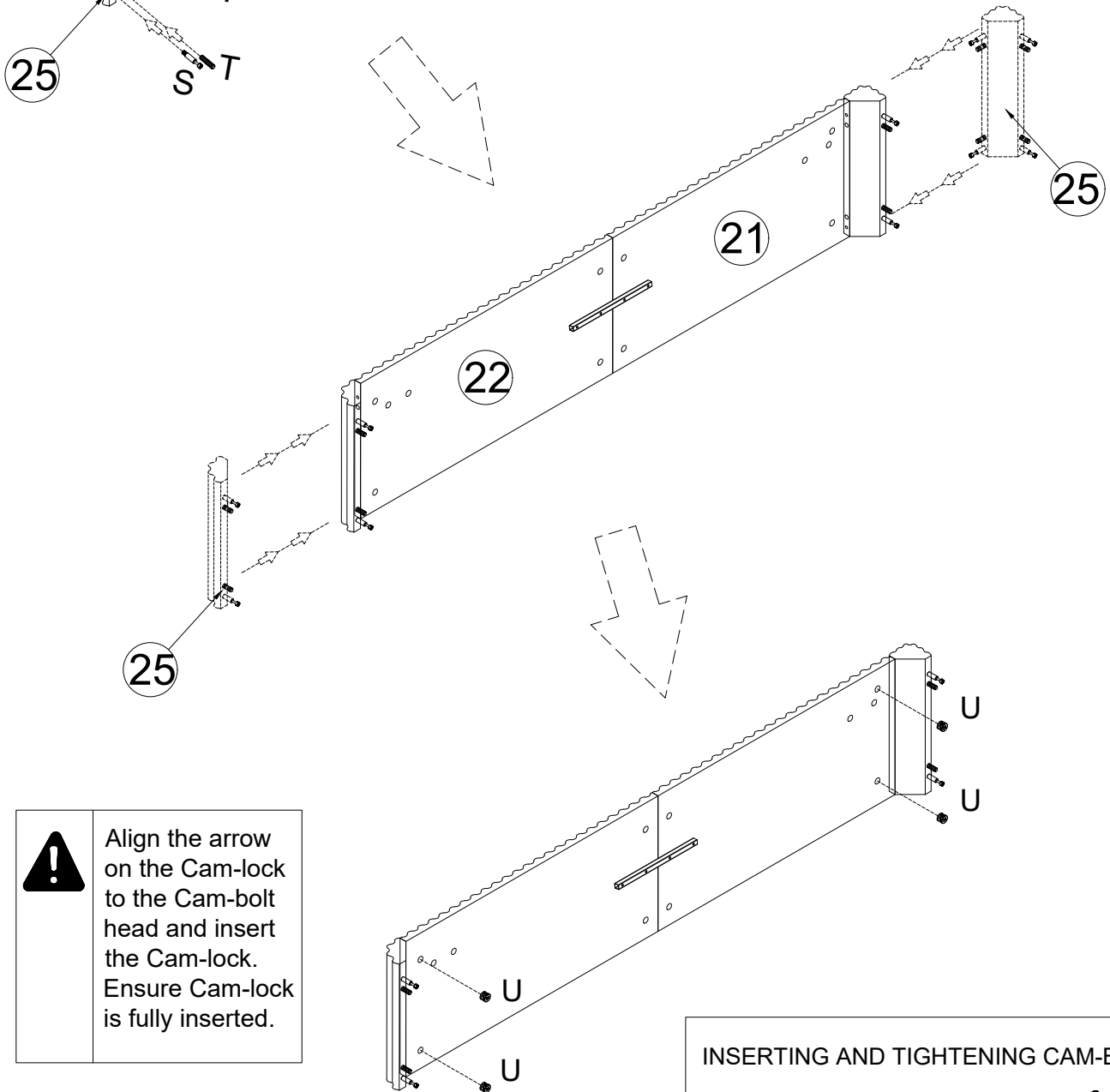
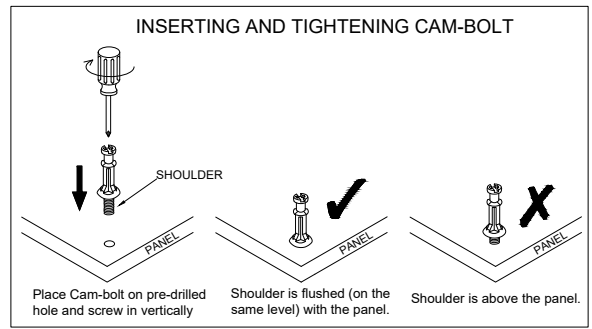
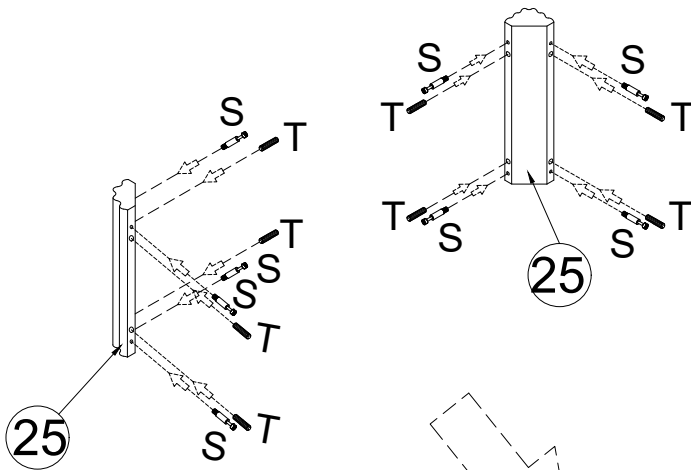

Align the arrow on the Cam-lock to the Cam-bolt head and insert the Cam-lock. Ensure Cam-lock is fully inserted.

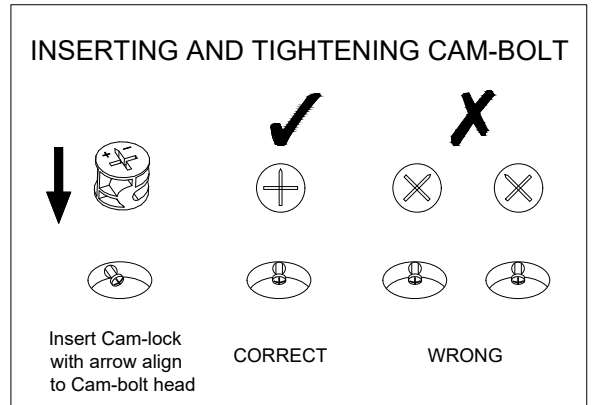
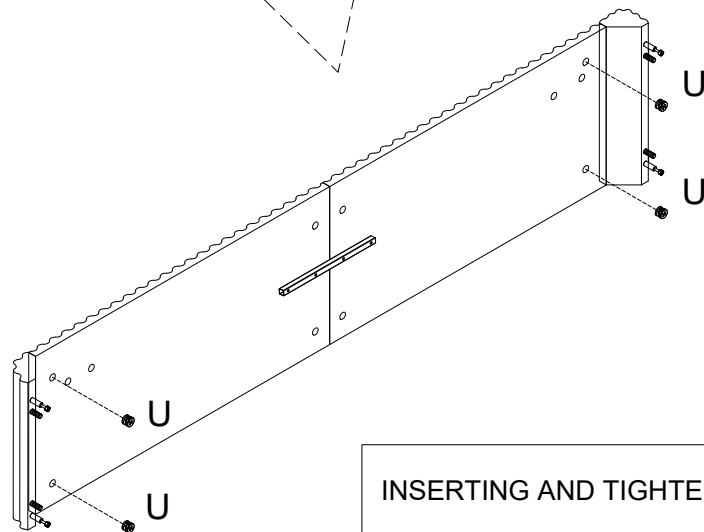

	S×8PCS
	T×8PCS
	U×4PCS

STEP 9

Note: Support the wooden plank during installation to prevent it from toppling over.

	<p>Align the arrow on the Cam-lock to the Cam-bolt head and insert the Cam-lock. Ensure Cam-lock is fully inserted.</p>
--	---

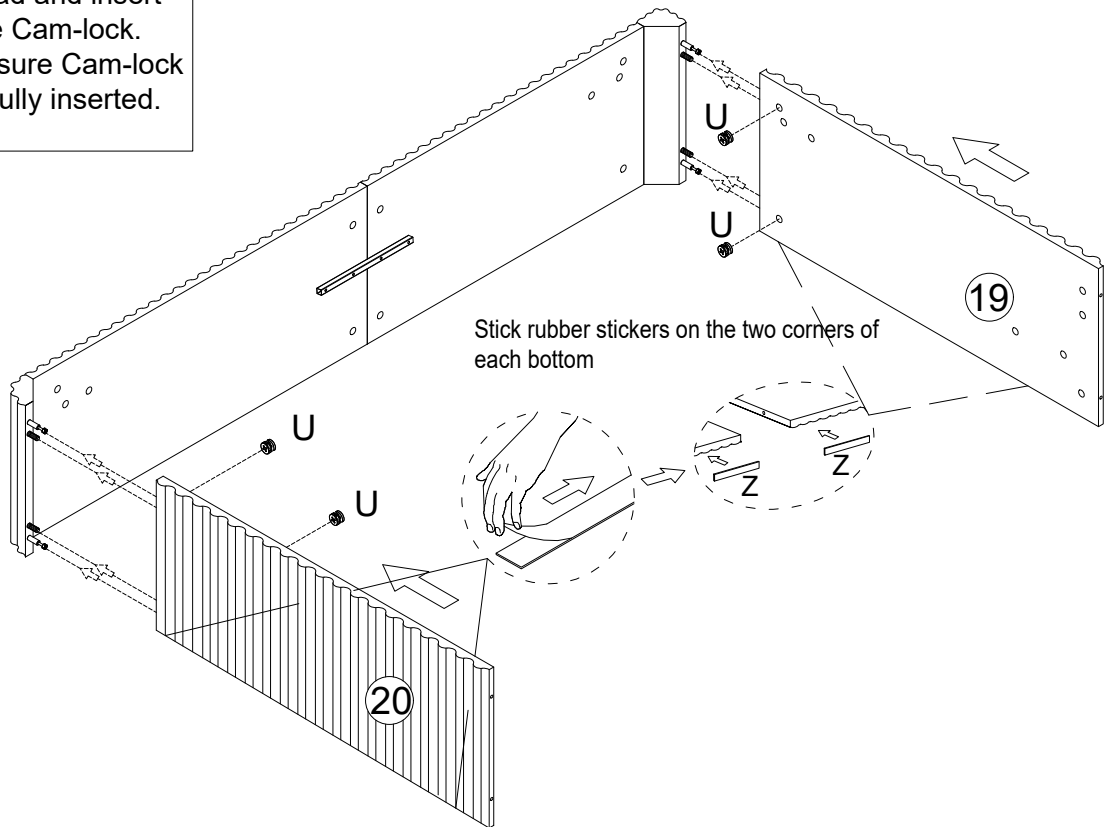



INSERTING AND TIGHTENING CAM-BOLT			
<p>Insert Cam-lock with arrow align to Cam-bolt head</p>	<p>CORRECT</p>	<p>WRONG</p>	

	<p>Z×4PCS</p>
	<p>U×4PCS</p>

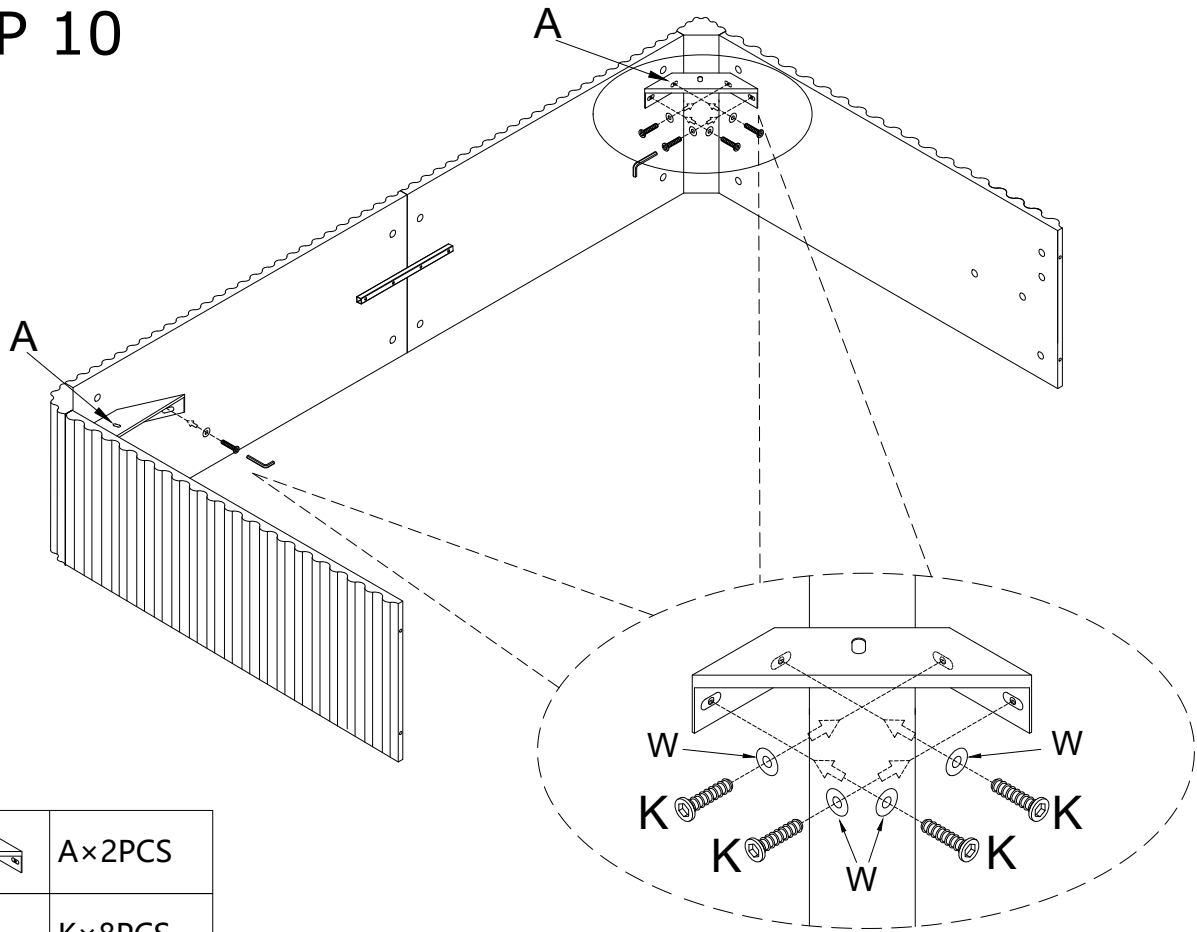

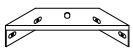
STEP 10



	A×2PCS
 M6X12	K×8PCS
	W×8PCS

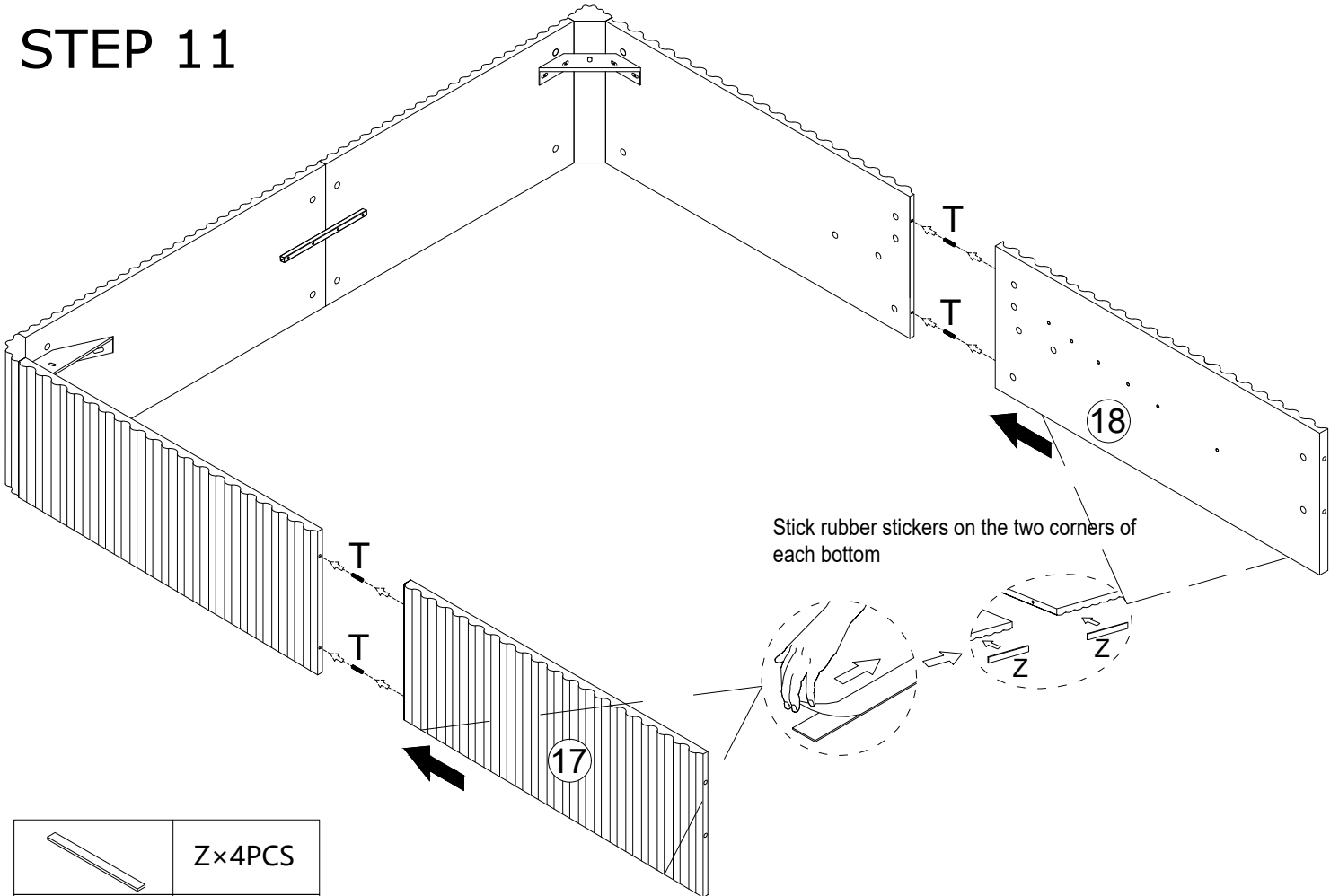



STEP 11

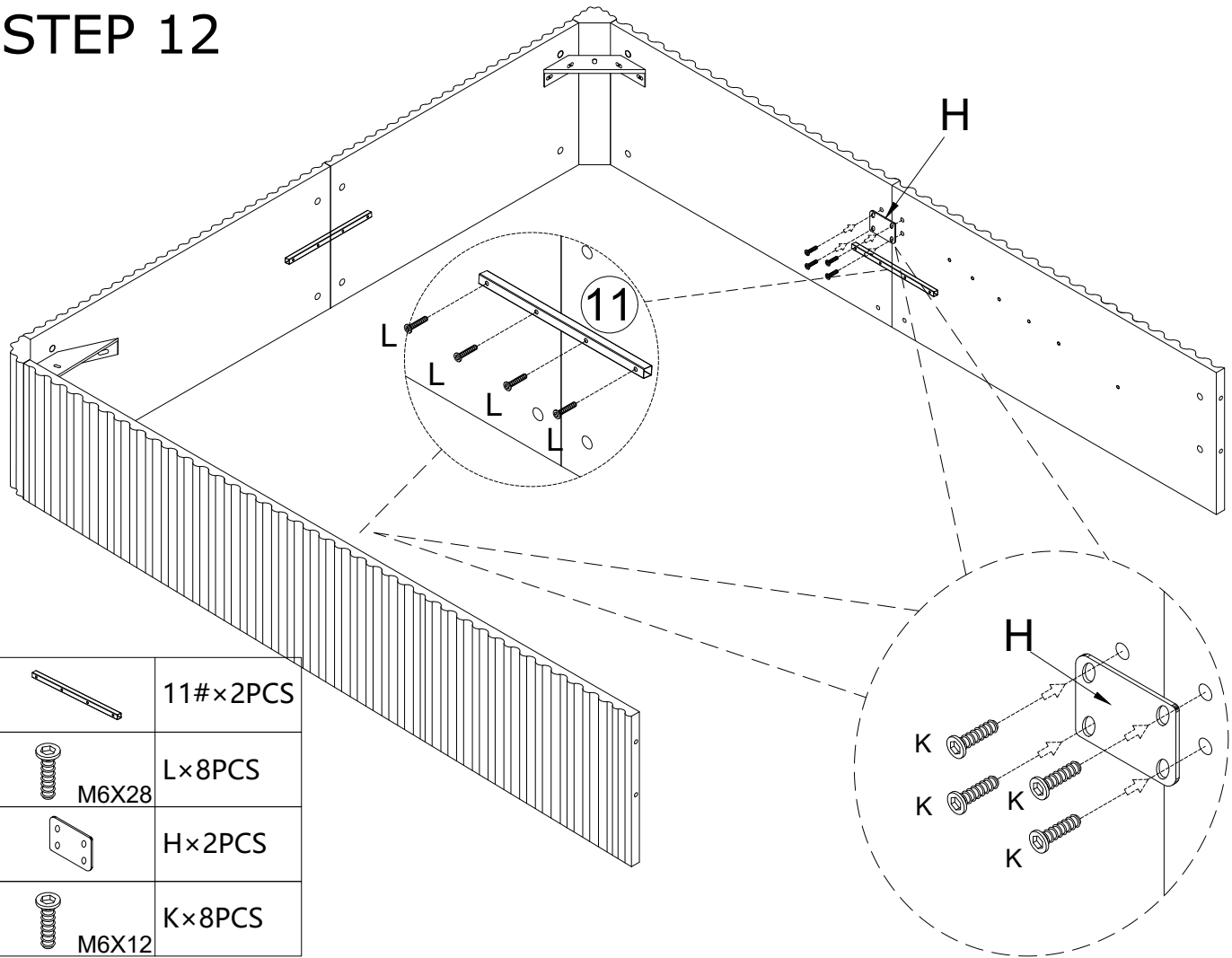

	Z×4PCS
	T×4PCS



STEP 12



	11#×2PCS
 M6X28	L×8PCS
	H×2PCS
 M6X12	K×8PCS

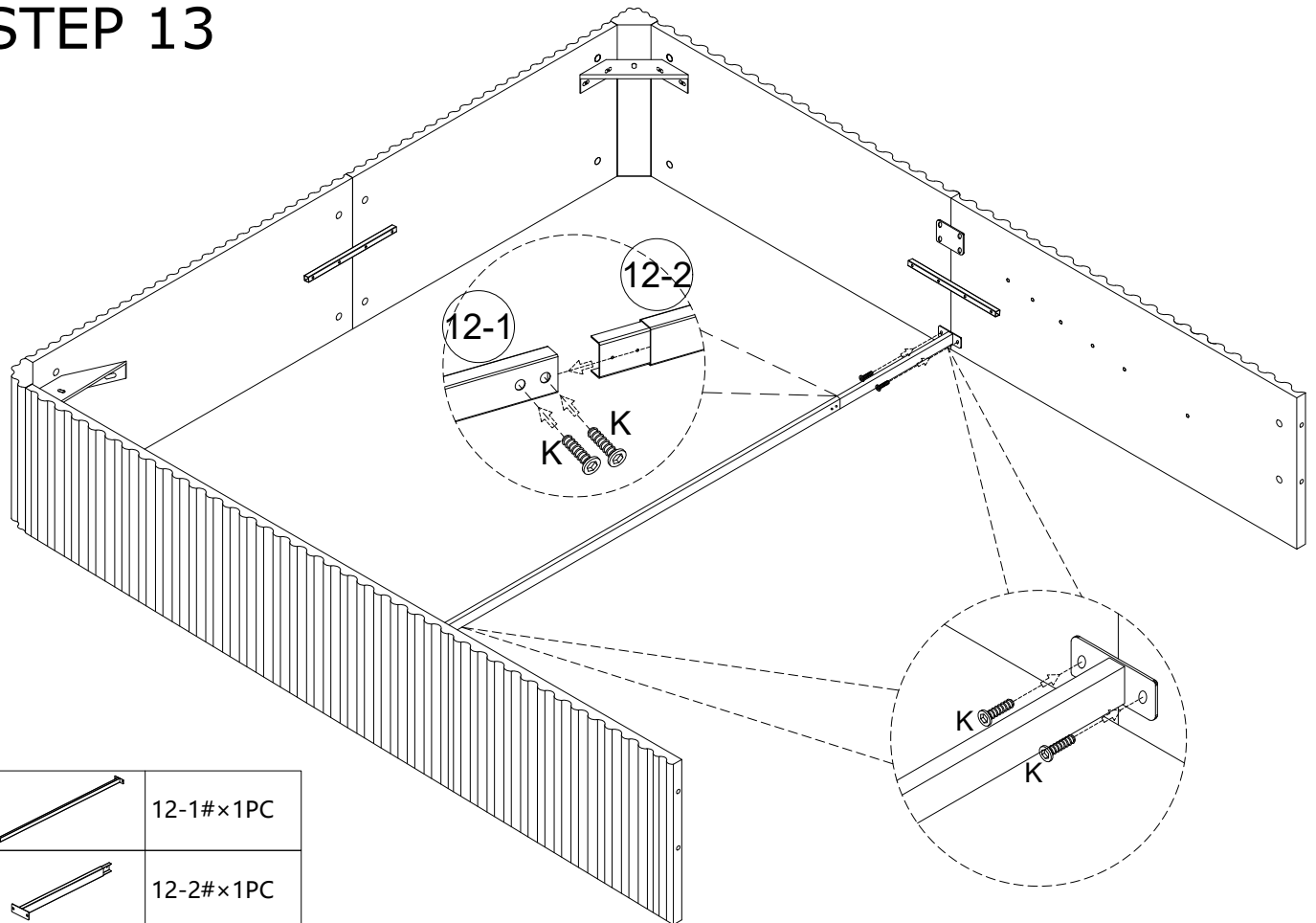

STEP 13

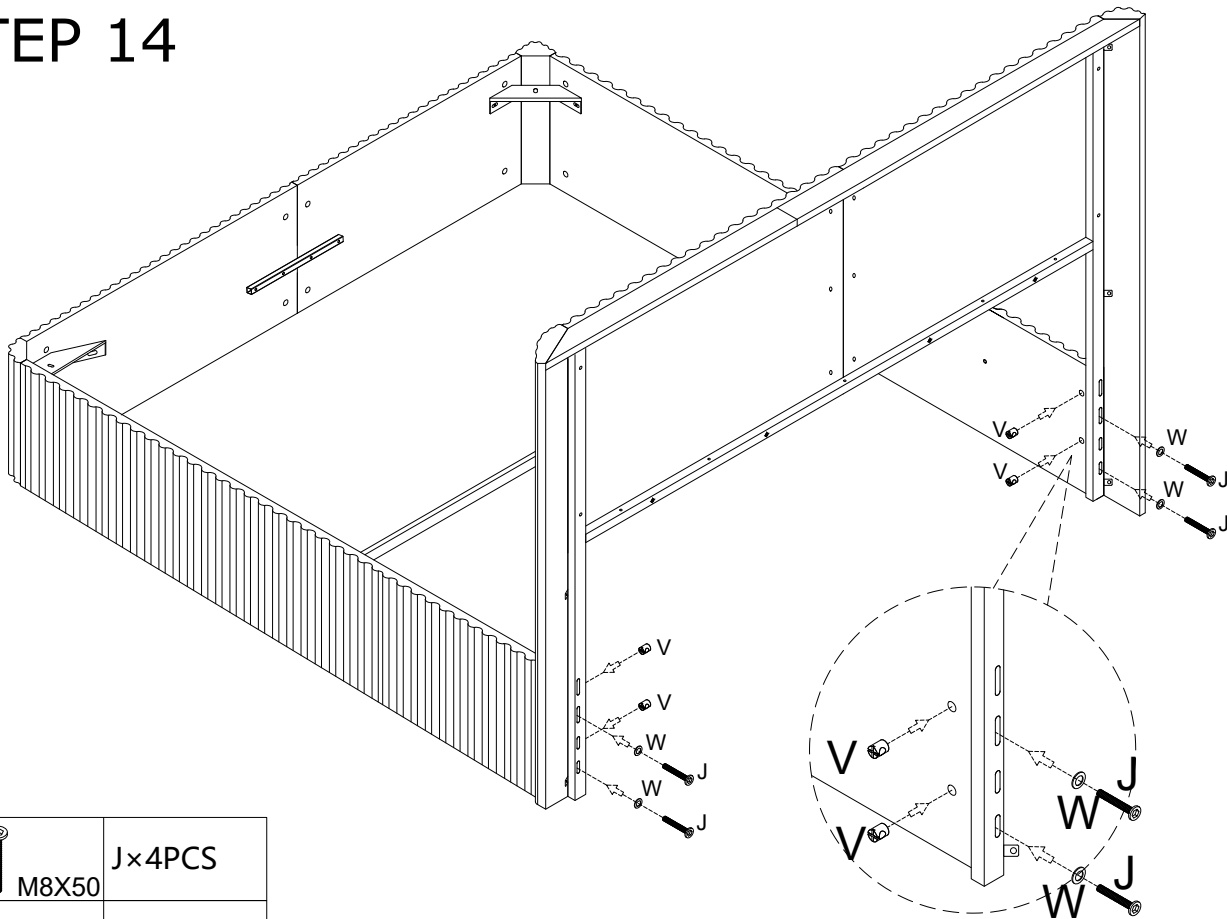

	12-1#×1PC
	12-2#×1PC
 M6X12	K×6PCS

STEP 14





 M8X50	J×4PCS
	V×4PCS
	W×4PCS

Note: When assembling, first insert the V accessory into the board, then tighten the screw. Note that the direction of the V parts should be aligned with hole position. If the screws cannot be locked, you can twist the V parts.

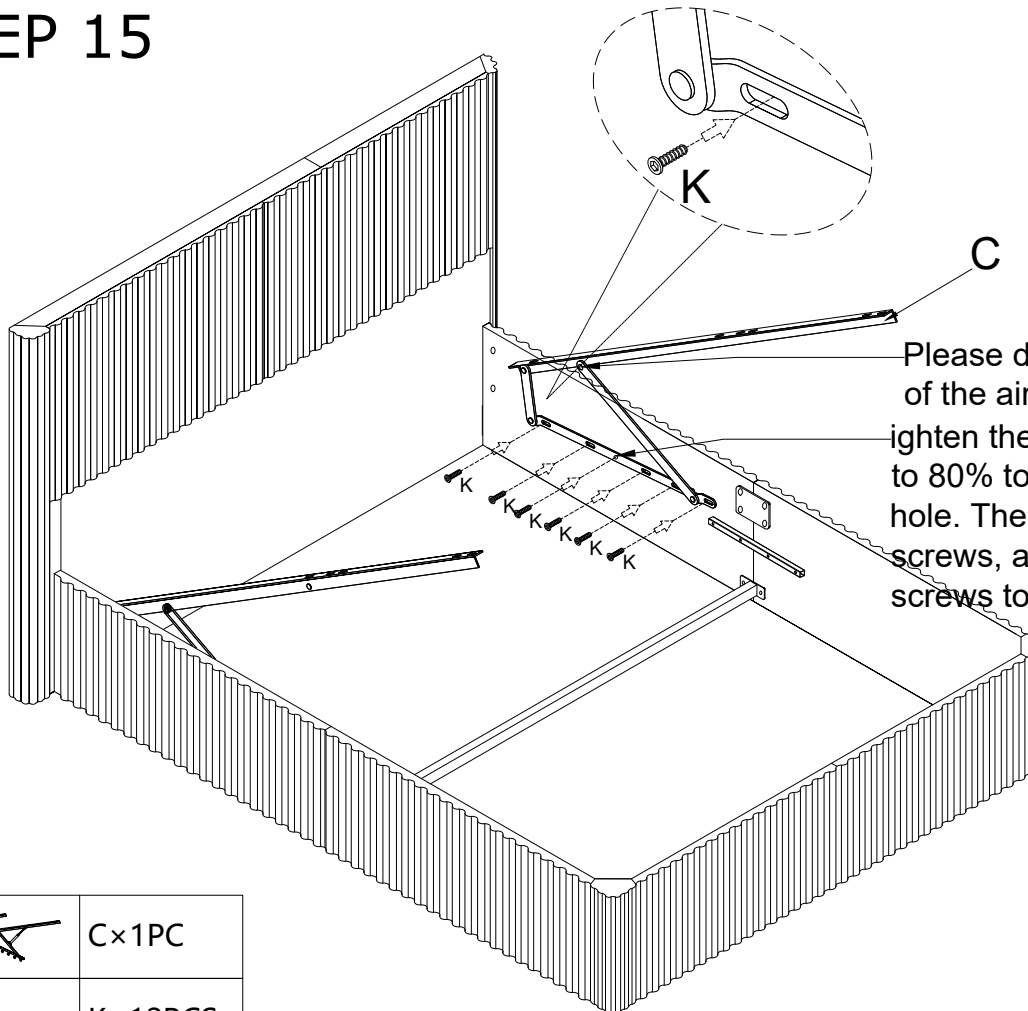
STEP 15





Please do not install the screws of the air pressure rod yet. Tighten the screw in the middle hole to 80% torque first as a positioning hole. Then fasten the remaining screws, and finally fully tighten all screws to 100% torque.

	C×1PC
 M6X12	K×12PCS

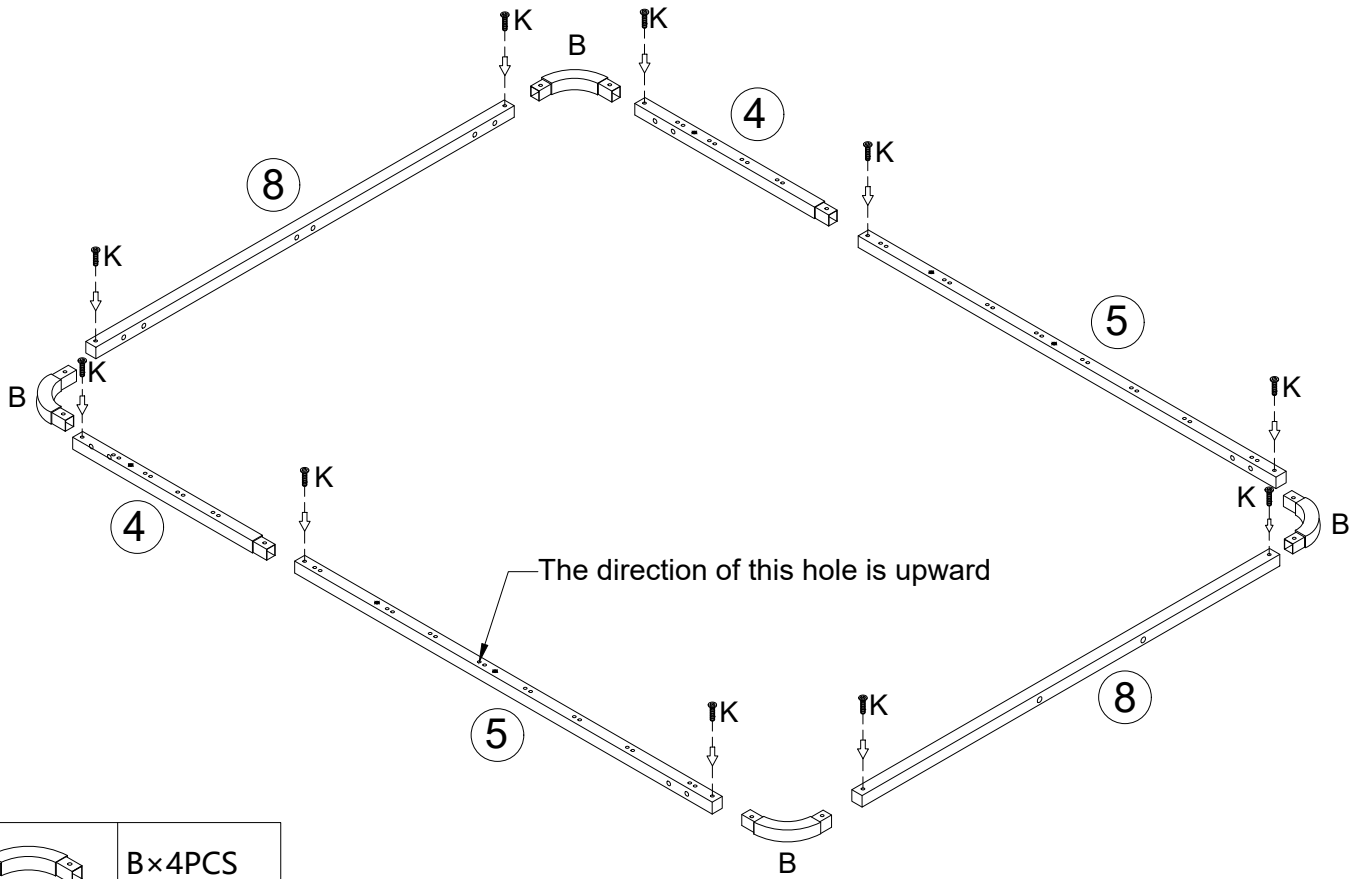
STEP 16





	B×4PCS
	K×10PCS
	M6X12

Flip the frame 180°

STEP 17

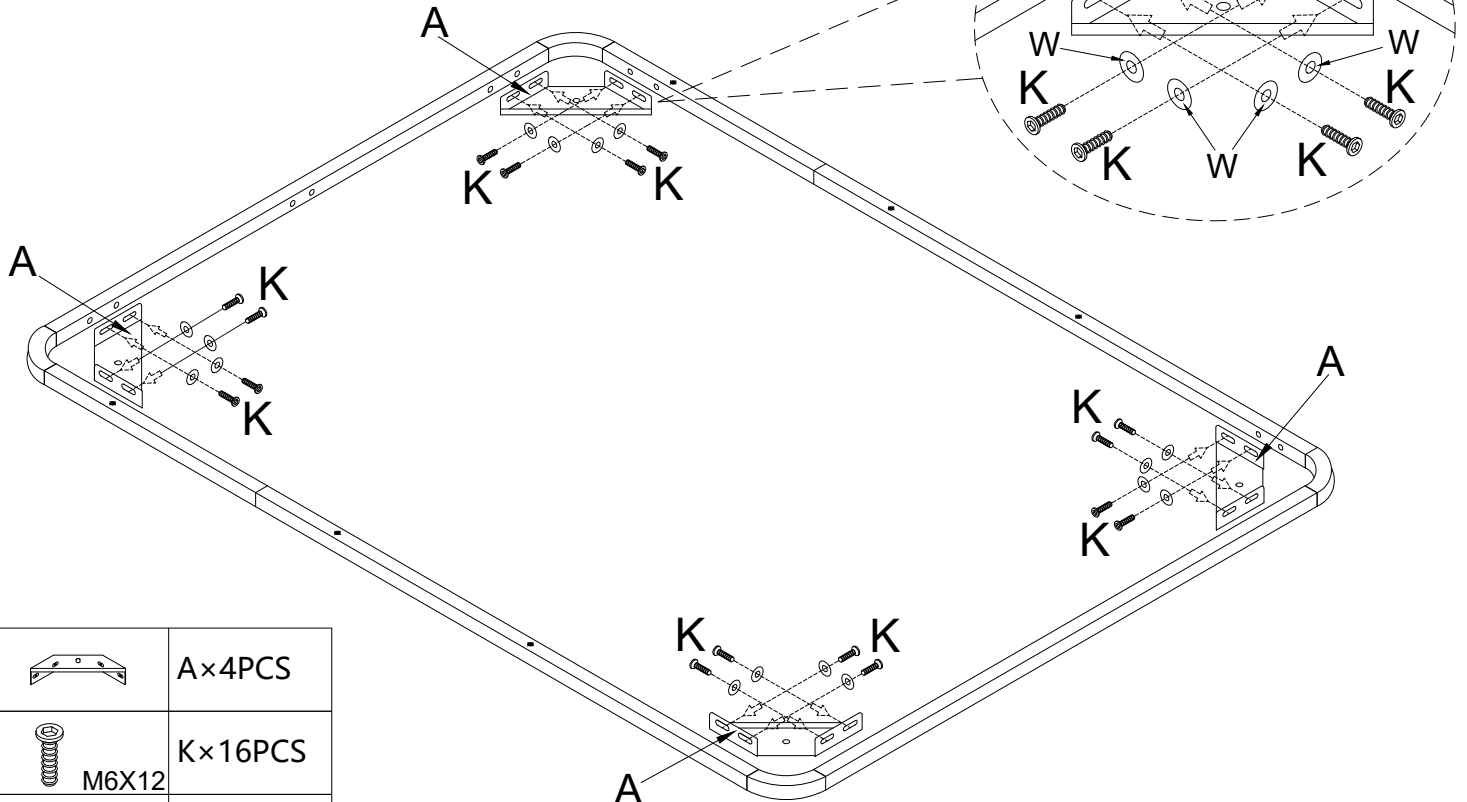
Flip the entire iron frame to install component A, pay attention to the direction of component A!!!

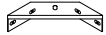

	A×4PCS
	K×16PCS
	M6X12
	W×16PCS

STEP 18

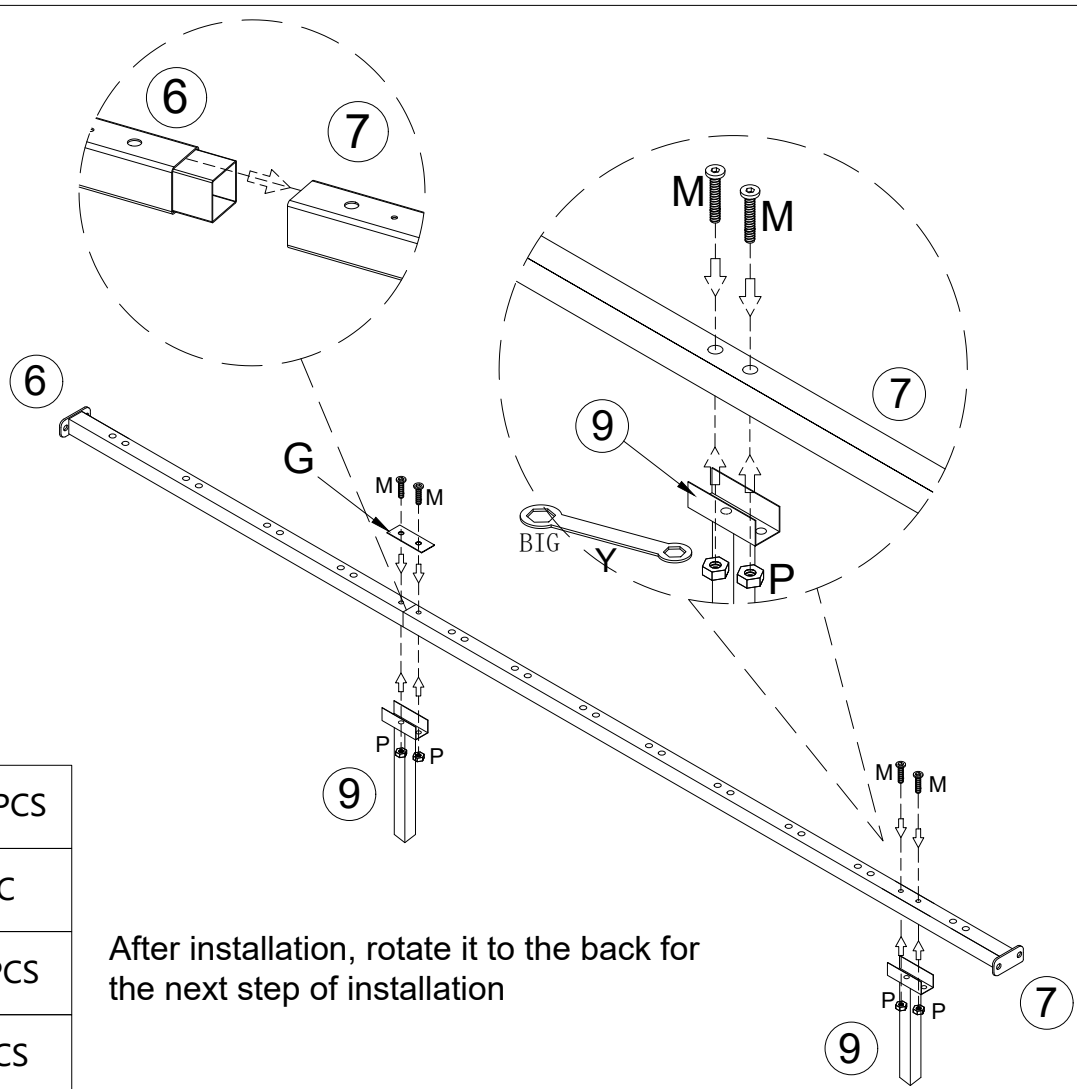

	9#×2PCS
	G×1PC
	M×4PCS M6X45
	P×4PCS M6

After installation, rotate it to the back for the next step of installation

STEP 19

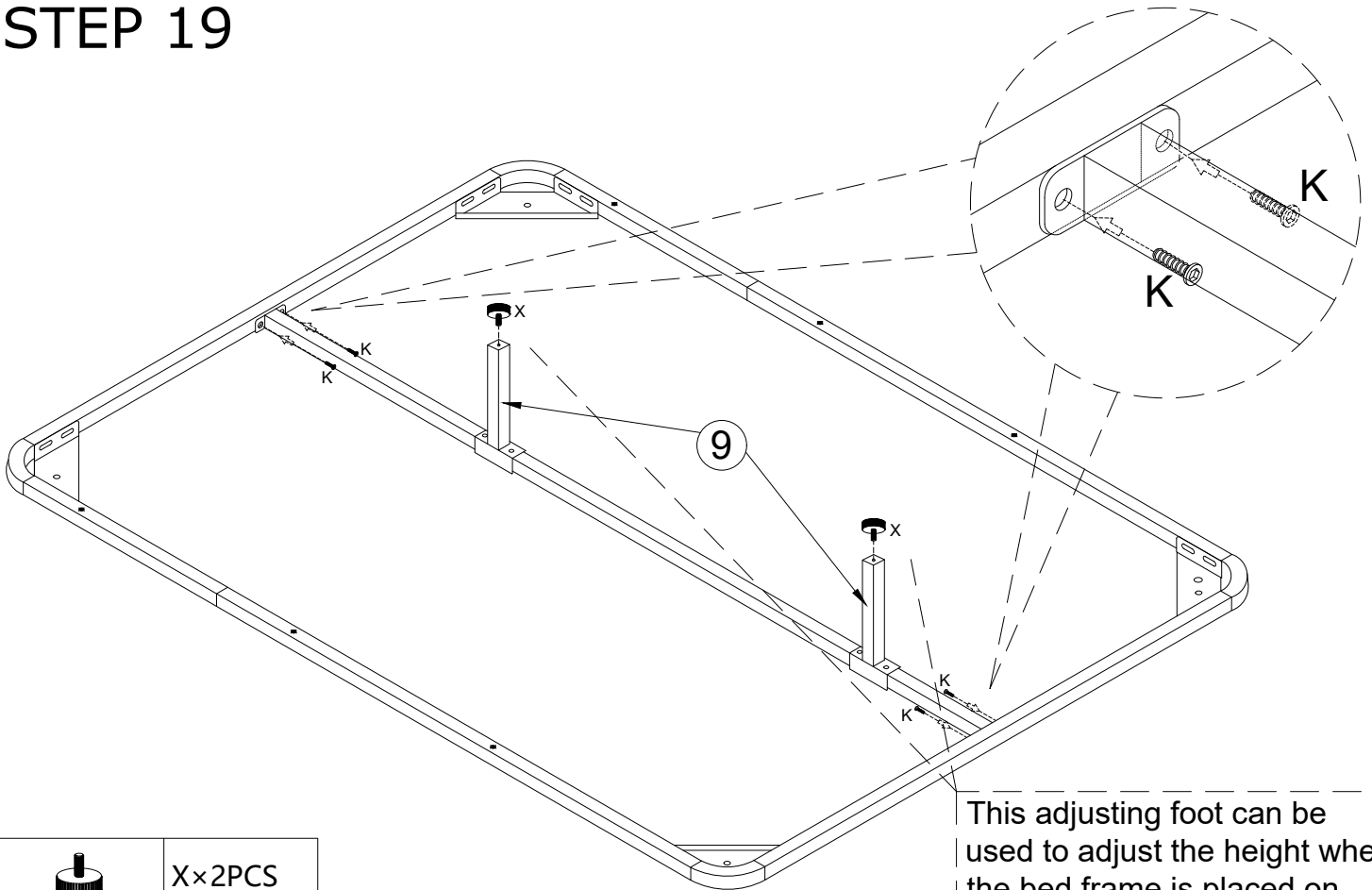

	X×2PCS
	K×4PCS M6X12

This adjusting foot can be used to adjust the height when the bed frame is placed on uneven ground

STEP 20

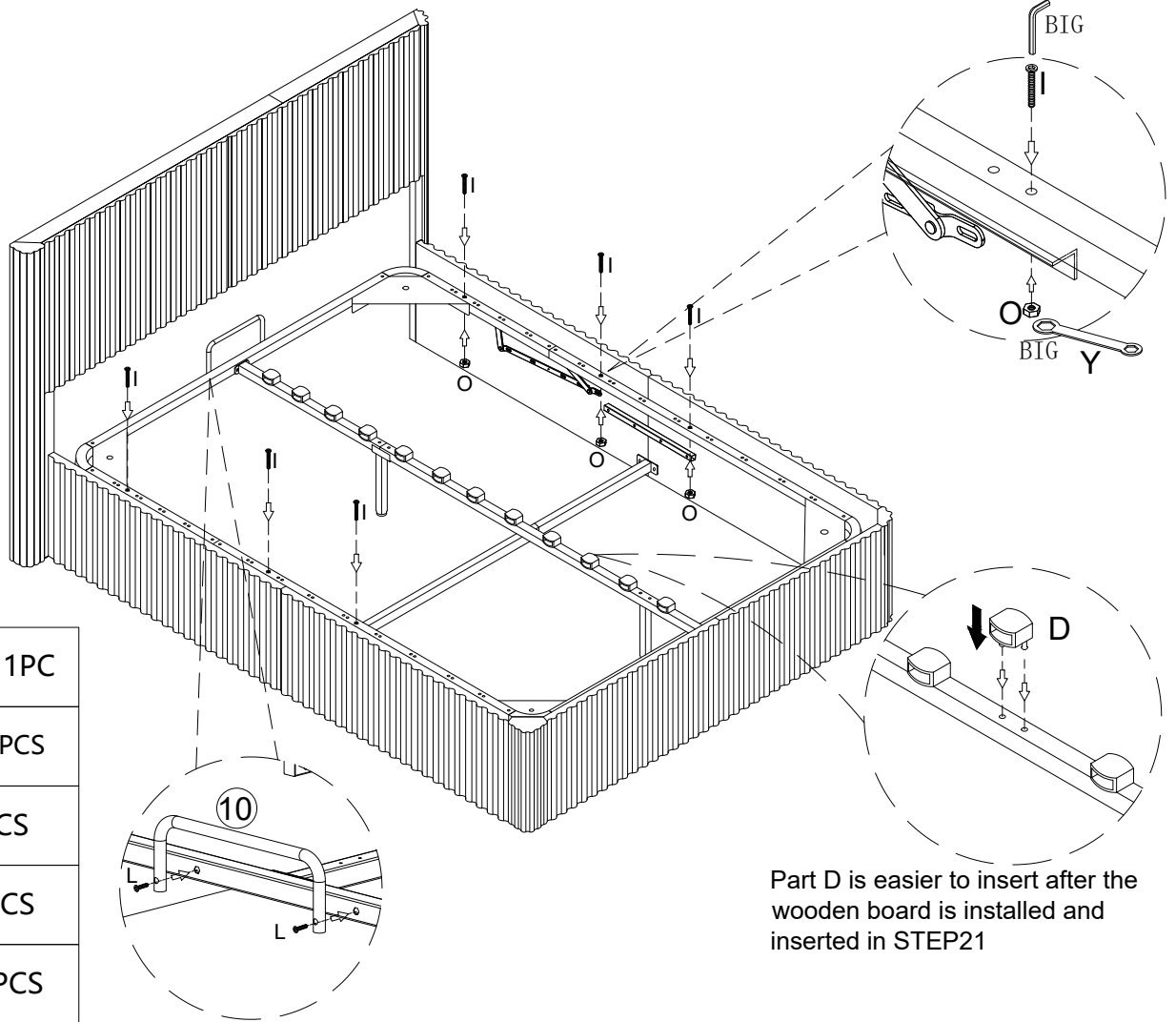

	10#×1PC
	D×12PCS
	I×6PCS
	L×2PCS
	O×6PCS

Part D is easier to insert after the wooden board is installed and inserted in STEP21

STEP 21

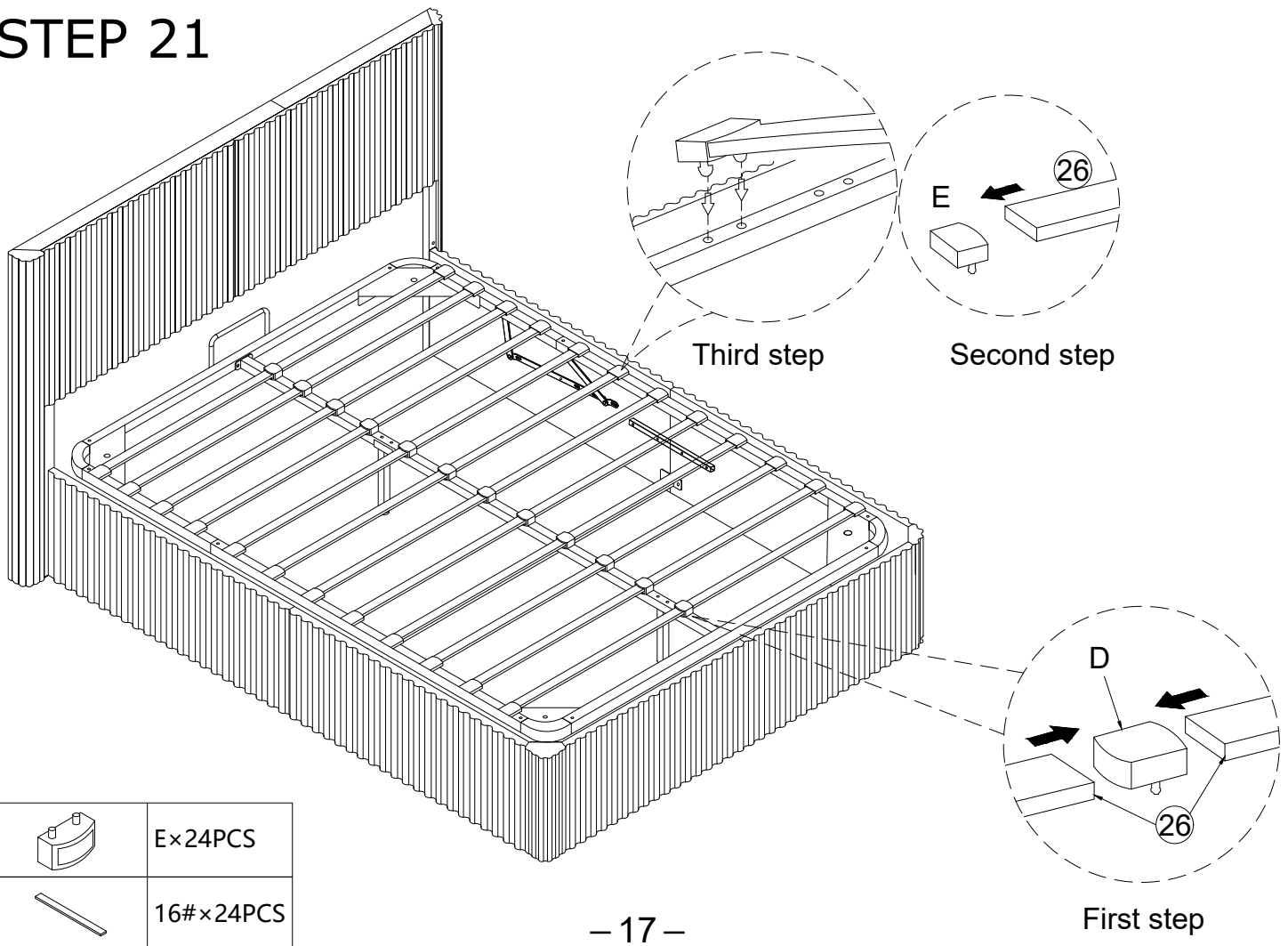

	E×24PCS
	16#×24PCS

STEP 22

Pressing down firmly at the center point is the most suitable way to lower the bed board

 It is recommended to have two people for the installation: one to install the air pressure rod nut, and the other to lift the bed frame to prevent it from toppling over

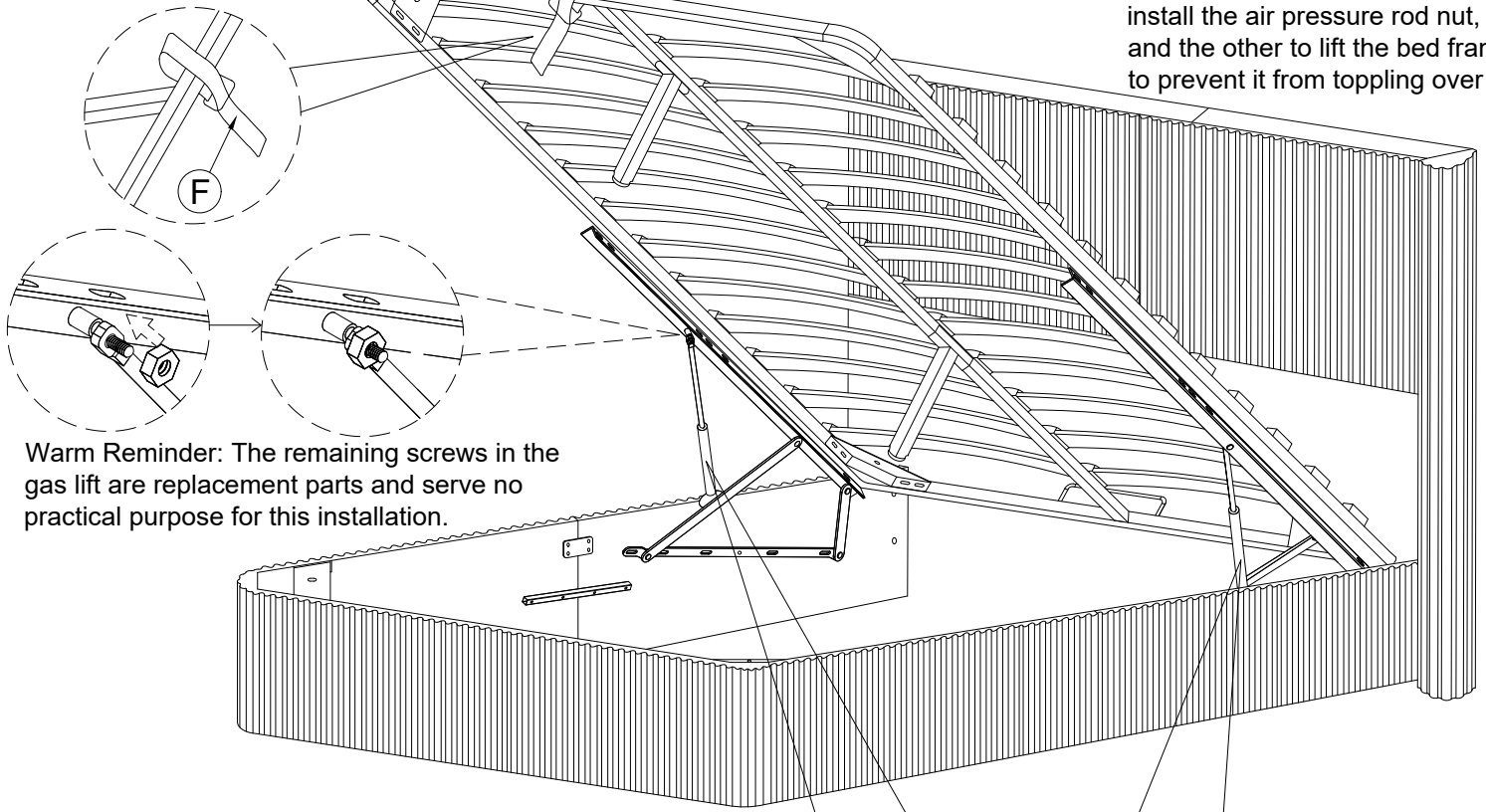

Warm Reminder: The remaining screws in the gas lift are replacement parts and serve no practical purpose for this installation.

This screw has been removed before pre-assembly. Please ensure to install the air pressure rod and lock all screws

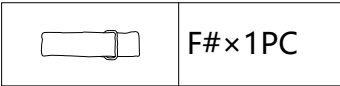

STEP 23

