

ACR1011WNSF456



53.13" x 23.38" x 27.75" (H x W x D)

Upright healthcare all-refrigerator certified to NSF/ANSI 456 with self-closing solid door, front lock, digital controls, and NIST-calibrated temperature readout

Highlights:

- Certified to NSF/ANSI 456 Vaccine Storage Standard
- Specially designed to meet current CDC/VFC vaccine refrigeration guidelines for convenient storage in pharmacies, medical offices, and other healthcare facilities
- Designed and constructed for reliable cold storage in healthcare facilities

Product Features:

EQTemp Healthcare Refrigerator	All-refrigerator designed to operate between 2 and 8°C for a variety of storage application in medical offices and other healthcare facilities
Certified to NSF/ANSI 456 Vaccine Storage Standard	Tested to comply with the latest standards
Certificate of calibration included	The temperature monitoring device (TMD) is calibrated to NIST standards in our ISO/IEC 17025:2017 certified calibration laboratory and ships with a 2-year certificate of calibration for your records
Temperature Range: 2° to 8°C	Preset to 5°C as recommended for many storage applications
Large capacity	Full 9.88 cu.ft. capacity inside conveniently slim footprint
External temperature readout	Includes continuous display of the current interior and high/low temperature, and can be switched from Celsius to Fahrenheit at the touch of a button
High/low temperature alarm	Audible alarm sounds if the interior temperature rises or falls out of set range
Buffered temperature probe	Thermometer probe is encased in a glass bead-filled bottle and stored in a fixed box on the center shelf. This is the ideal way to produce temperature readings closest to stored contents, as recommended by the CDC and VFC's guidelines

ACR1011WNSF456 Specifications:

Overview	
Height of Cabinet	53.13" (135 cm)
Width	23.38" (59 cm)
Width with Door Open	23.88" (61 cm)
Depth	27.75" (70 cm)
Depth with door at 90°	45.25" (115 cm)
Capacity	9.88 cu.ft. (280 L)
Defrost Type	Automatic
Door	White
Cabinet	White
US Electrical Safety	ETL
Canadian Electrical Safety	ETL-C
Sanitation	ETL-S to NSF 456
Amps	2.0
Voltage/Frequency	115 V AC/60 Hz
Weight	116.8 lbs. (53 kg)
Shipping Weight	191.0 lbs. (87 kg)
Parts & Labor Warranty	1 Year
Compressor Warranty	5 Years
UPC	761101083094
Refrigerator Features	
Door Swing	RHD
Reversible	Factory Reversible
Shelf Type	Wire
Shelf Qty	4
Adjustable Shelves	Yes
Thermostat Type	Digital
Fan Type	Interior
Refrigerant Type	R600a
Refrigerant Amount	2.0oz.
High Side PSI	1.45
Low Side PSI	0.85
Level Legs Qty	2
Interior Light	Yes
Temperature Range	2° to 8°C
Dimensions	
Interior Height	44.63" (113 cm)
Interior Width	20.0" (51 cm)

Interior Depth	21.5" (55 cm)
Compressor Step Height	9.0" (23 cm)
Compressor Step Width	20.0" (51 cm)
Compressor Step Depth	8.0" (20 cm)

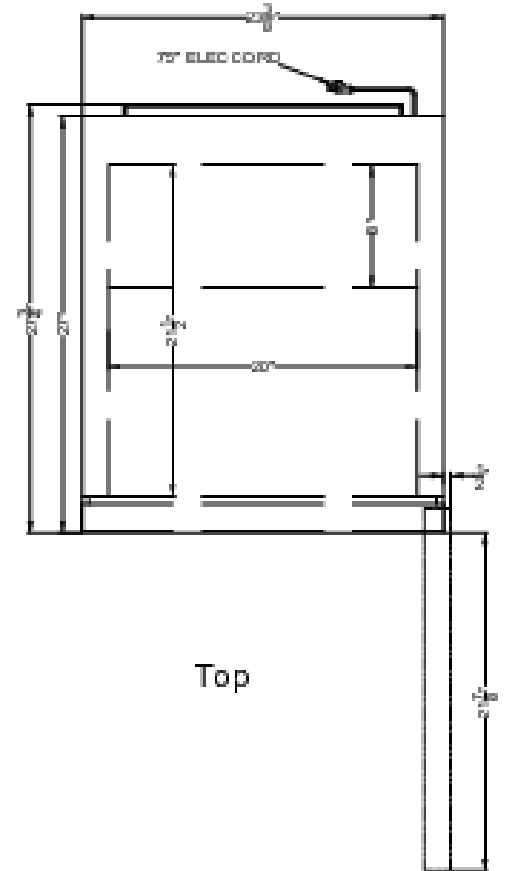

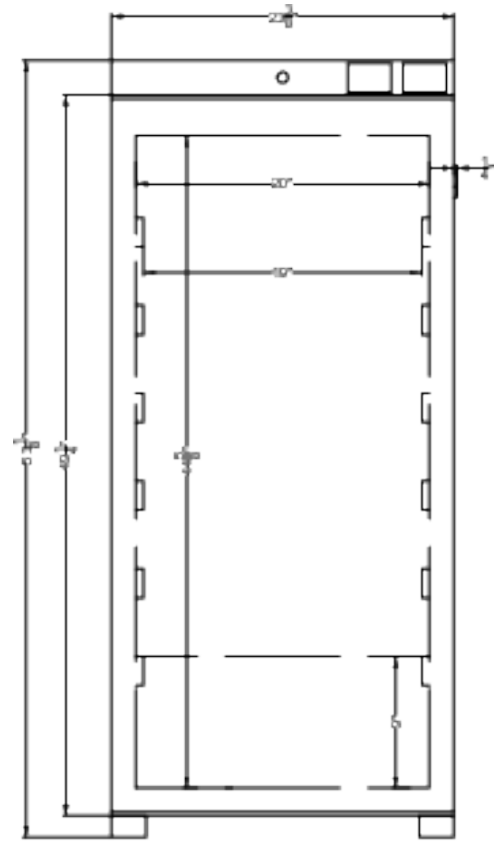

Front