

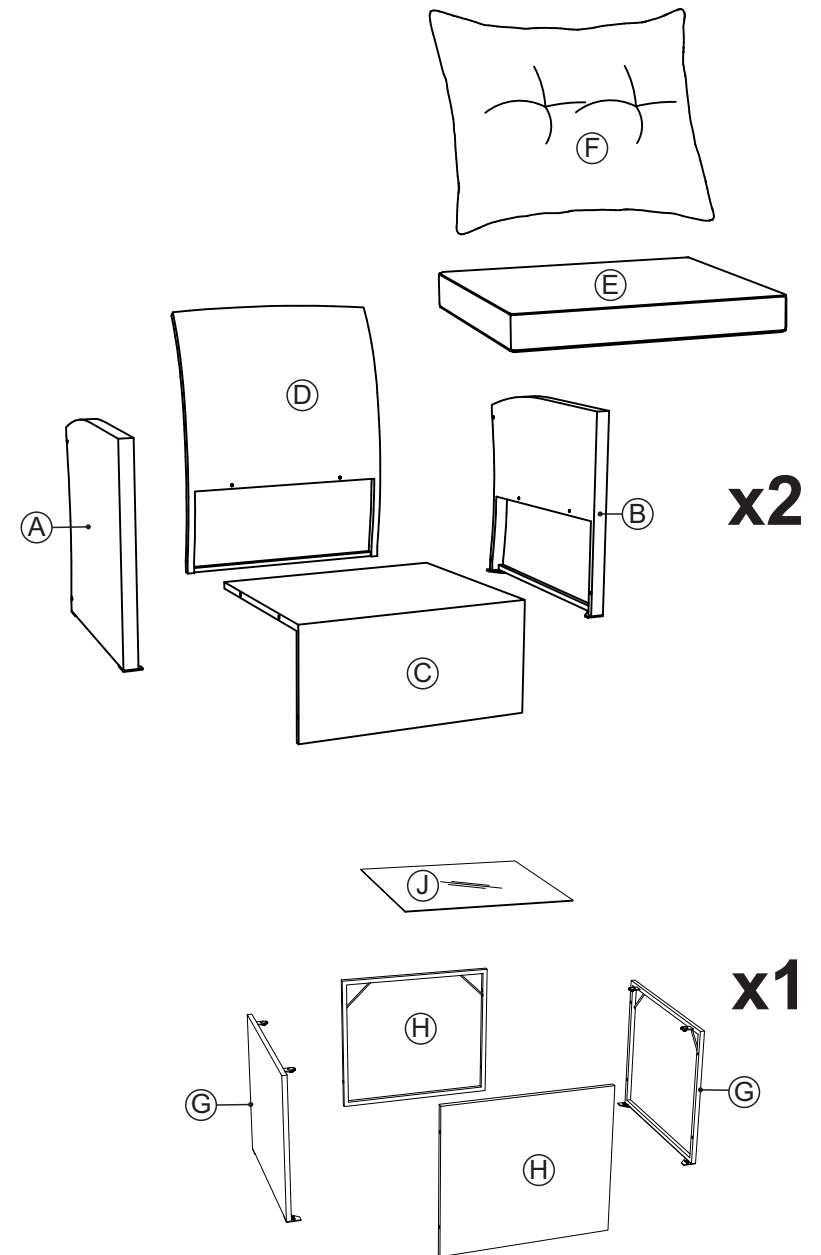



## Before You Start

- ⚠ Please read all instructions carefully.
- ⚠ Retain instructions for future reference.
- ⚠ Separate and count all parts and hardware.
- ⚠ Read through each step carefully and follow the proper order.
- ⚠ We recommend that, where possible, all items are assembled near to the area in which they will be placed in use, to avoid moving the product unnecessarily once assembled.
- ⚠ Always place the product on a flat, steady and stable surface.
- ⚠ Keep all small parts and packaging materials for this product away from babies and children as they potentially pose a serious choking hazard.



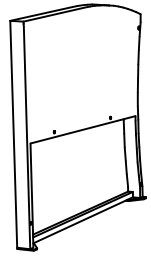

(A) x2

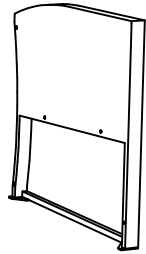

(B) x2

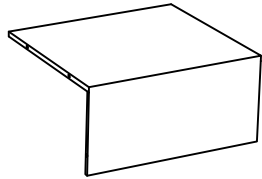

(C) x2

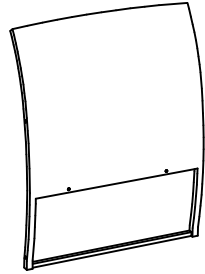

(D) x2

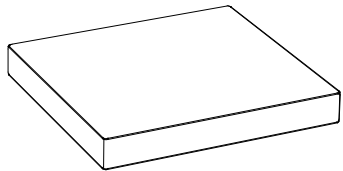

(E) x2

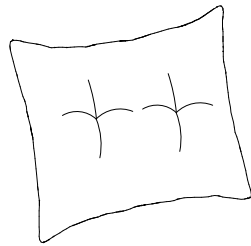

(F) x2

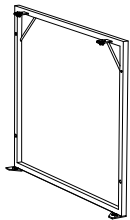

(G) x2

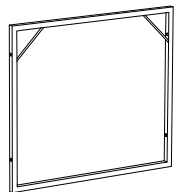

(H) x2



410x410x5 mm  
(J) x1



M6x25 mm

(1)

x8



M6x35 mm

(2)

x16

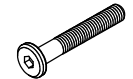

M6x55 mm

(3)

x20



Ø6x14x1mm

(4)

x32



40x40x66 mm

(5)

x12



4x98 mm

(6)

x2

Allen Key

1

x2

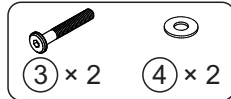
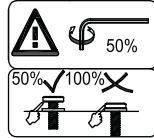
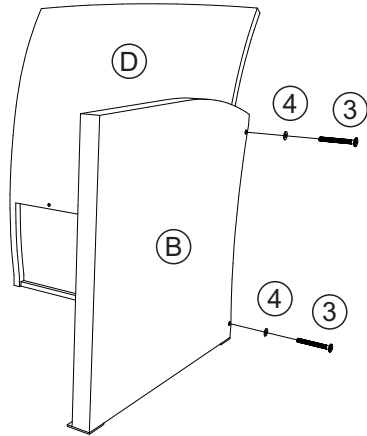

2

x2

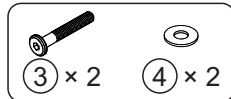
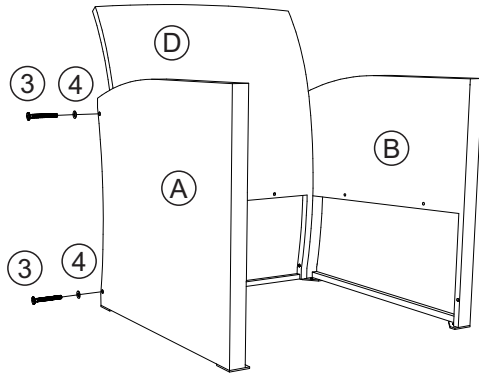

3

x2

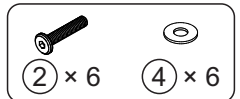
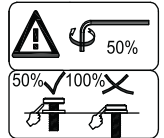
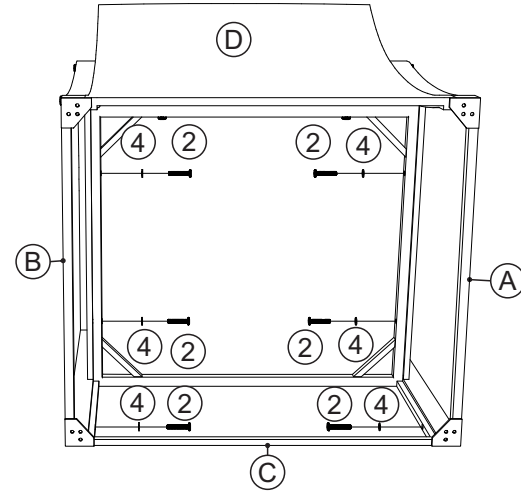

4

x2

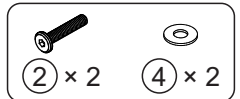
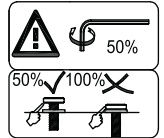
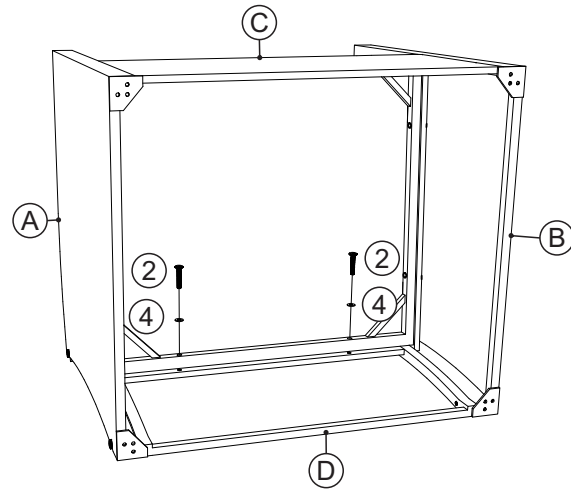

5

x2

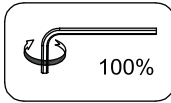
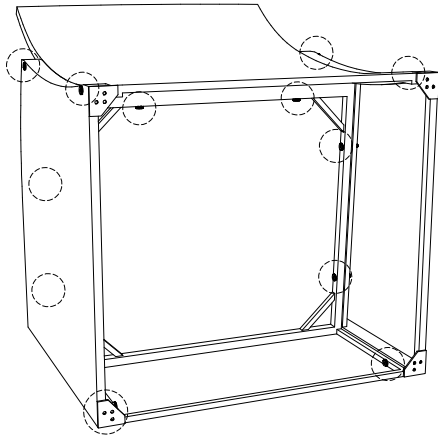

6

x2

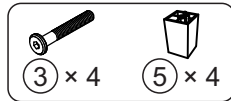
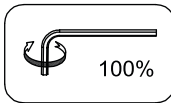
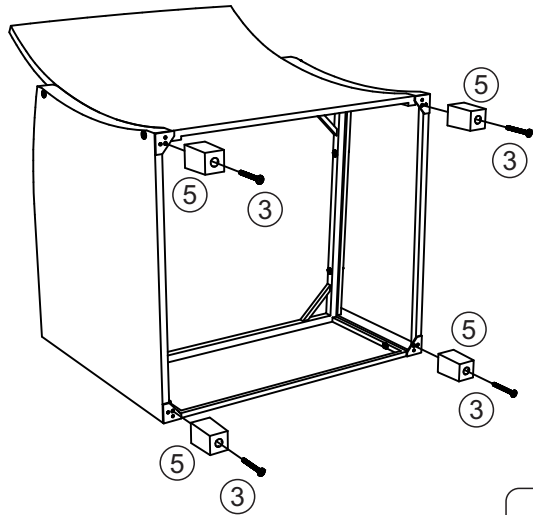

7

x2

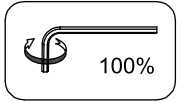
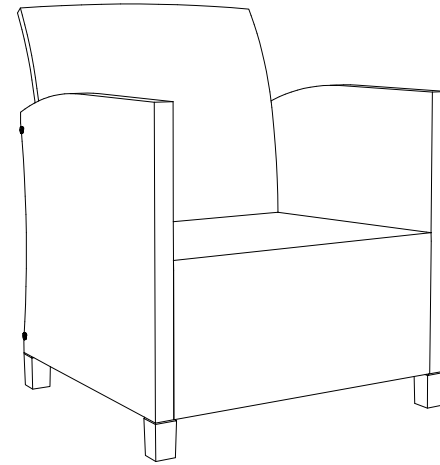

8

x2

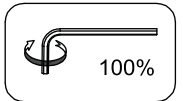
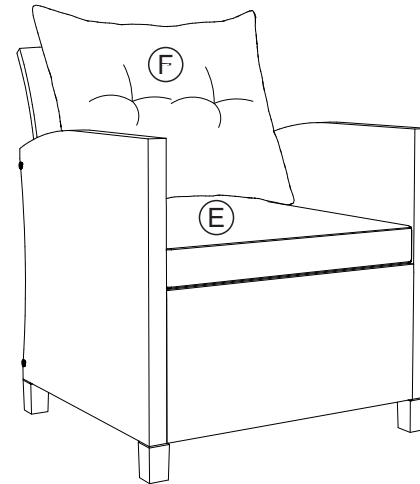

9

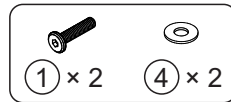
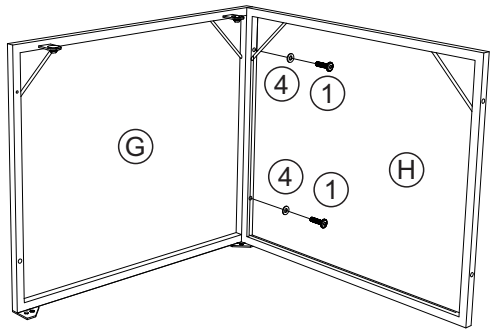

11

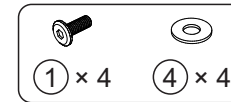
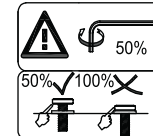
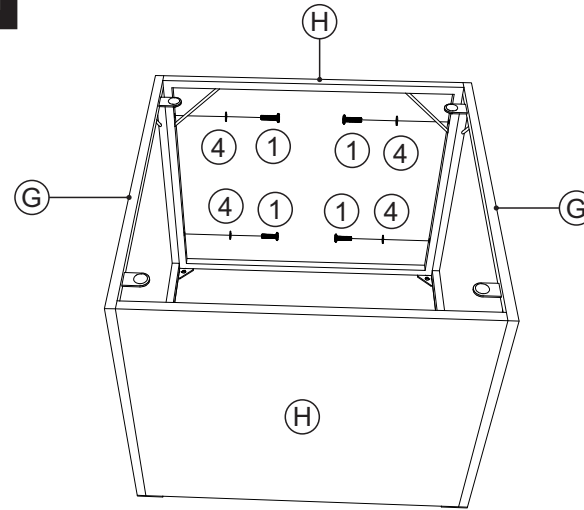

10

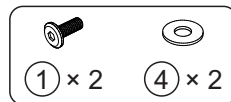
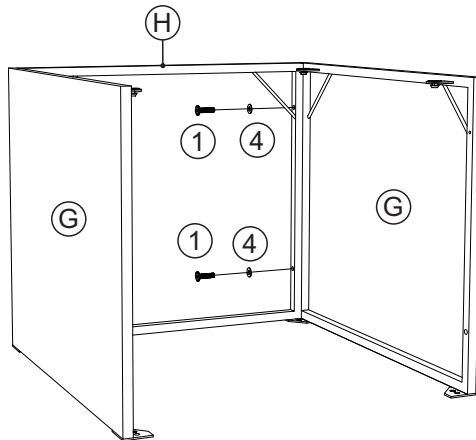

12

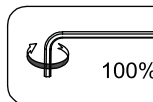
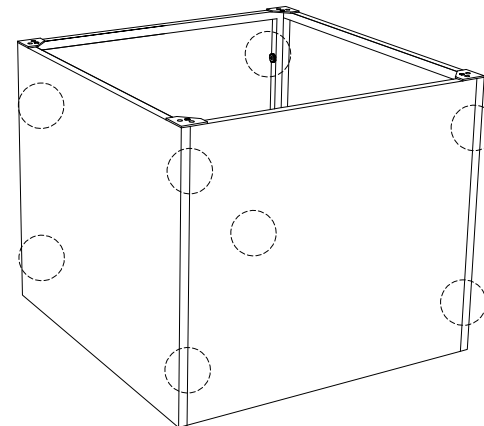

13

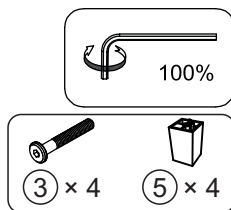
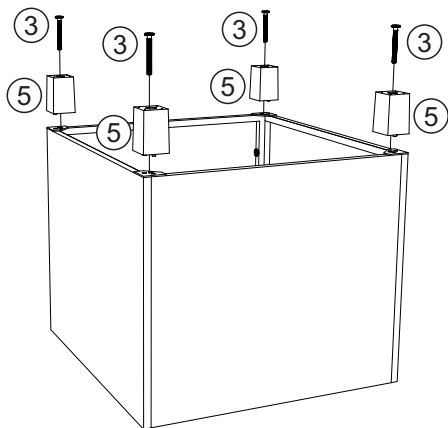

14

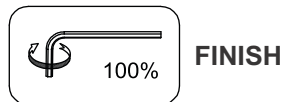
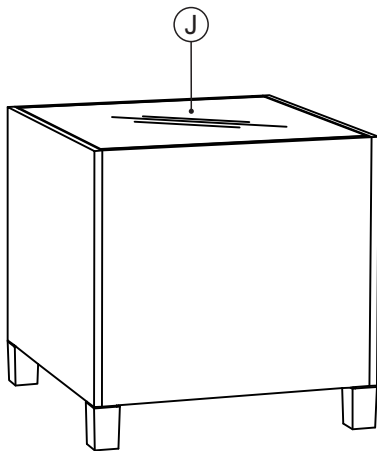

15

