

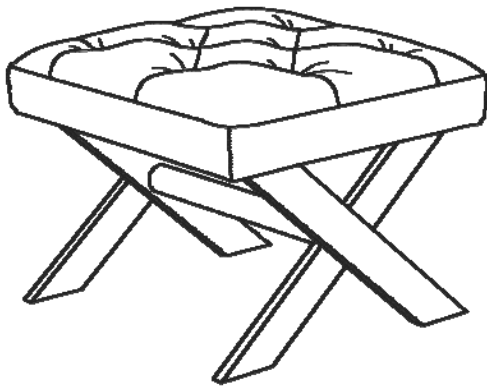



Thank you for purchasing the **BENCH!**

Before you start, here is some helpful advice:

1. We suggest you spend a short time reading through this leaflet and then follow the simple step by step instructions.
2. Owing to the size and weight of the bench, we recommend that it is assembled by two adults, on a carpeted or padded area, in the room that it is intended for. Approximate assembly time: 30 minutes.
3. Please do not use any tools other than those provided or recommended in these instructions.
4. Please do not throw away any of the packaging or instructions until you have checked all the components and hardware and the furniture is fully assembled.
5. Assemble all components loosely until advised to tighten. Depending on use, it may be necessary to tighten the components from time to time, so please save the tools that have been provided.
6. Please keep all pieces out of reach of small children.

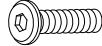
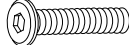

Hardware:

A		Bolt M6x40mm	x 12
B		Bolt M6x60mm	x 2
C		Spring Washer M6	x 12
D		Flat Washer M6	x 14
E		Plastic Washer	x 2
F		Allen Wrench	x 1

Component:

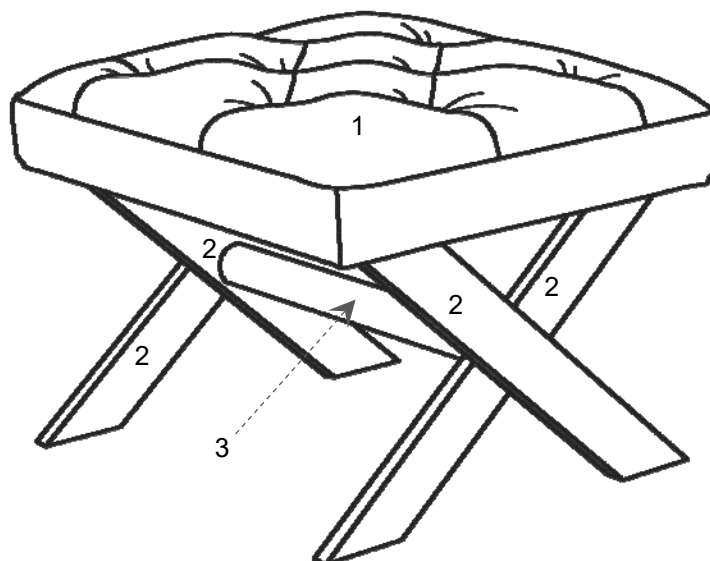

1 Bench Body x1

2 Bench Leg x4

3 Middle Rail x1

BENCH

STEP 1:

Put **Bench Body (2)** on a carpeted or padded area.

Position 1 piece of **Bench Leg (2)** to the apron inside without wooden block at first.

Attach by using 3 pieces of **Short Bolt (A)**, 3 pieces of **Spring Washer (C)** and 3 pieces of **Flat Washer (D)** as shown.

Then position another pieces of **Bench Leg (2)** to the apron inside with wooden block.

Attach by using 3 pieces of **Short Bolt (A)**, 3 pieces of **Spring Washer (C)** and 3 pieces of **Flat Washer (D)** as shown.

Repeat the same steps for the remaining **Bench legs (2)** to the other side of **Bench Body (1)**.

Do not fully tighten the **Short Bolts (A)** at this step.

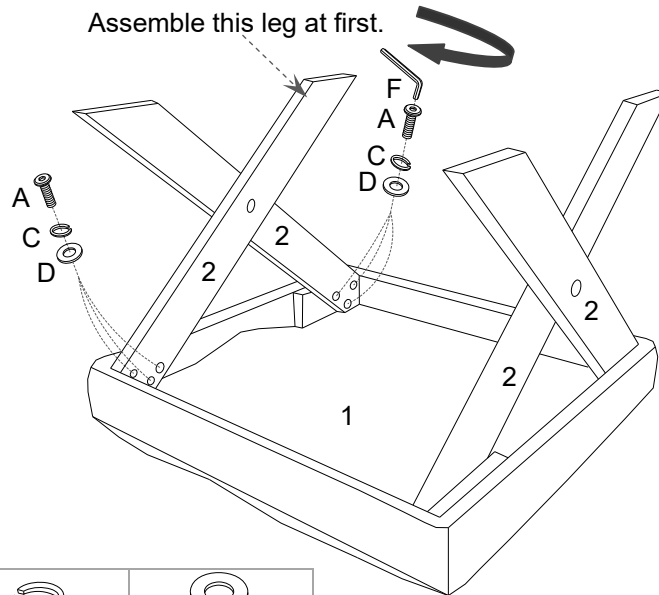

Ax12	Dx12	Dx12

Hardware & Tool required

STEP 2:

Position **Middle Rail (3)** to the assembled **Bench Legs (2)** as shown.

Attach by using 2 pieces of **Long Bolt (B)**, 2 pieces of **Spring Washer (D)** and 2 pieces of **Plastic Washer (E)**.

Use **Allen Wrench (F)** to tighten all the **Bolts (A&B)** clockwise until secure at this step.

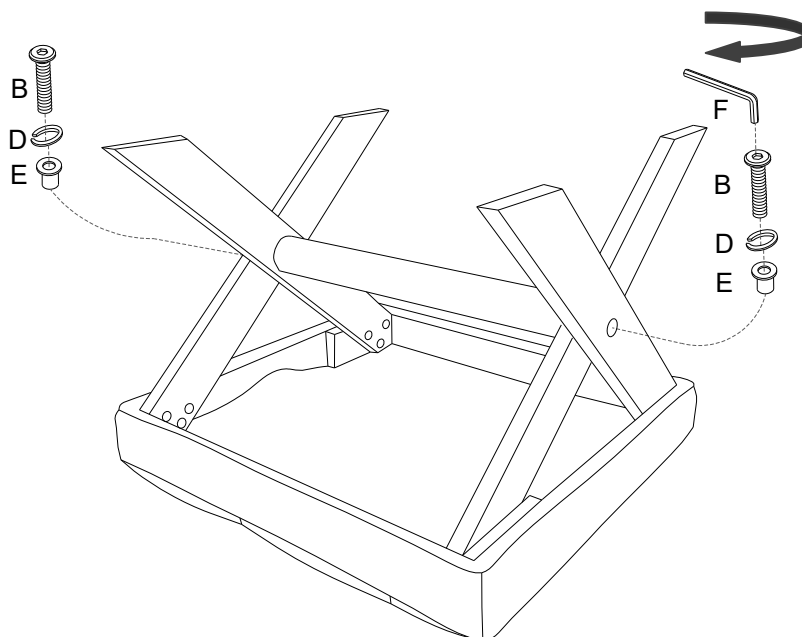

Bx2	Dx2	Ex2	Fx1

Hardware & Tool required

BENCH

STEP 3:

Carefully turn over the assembled bench.

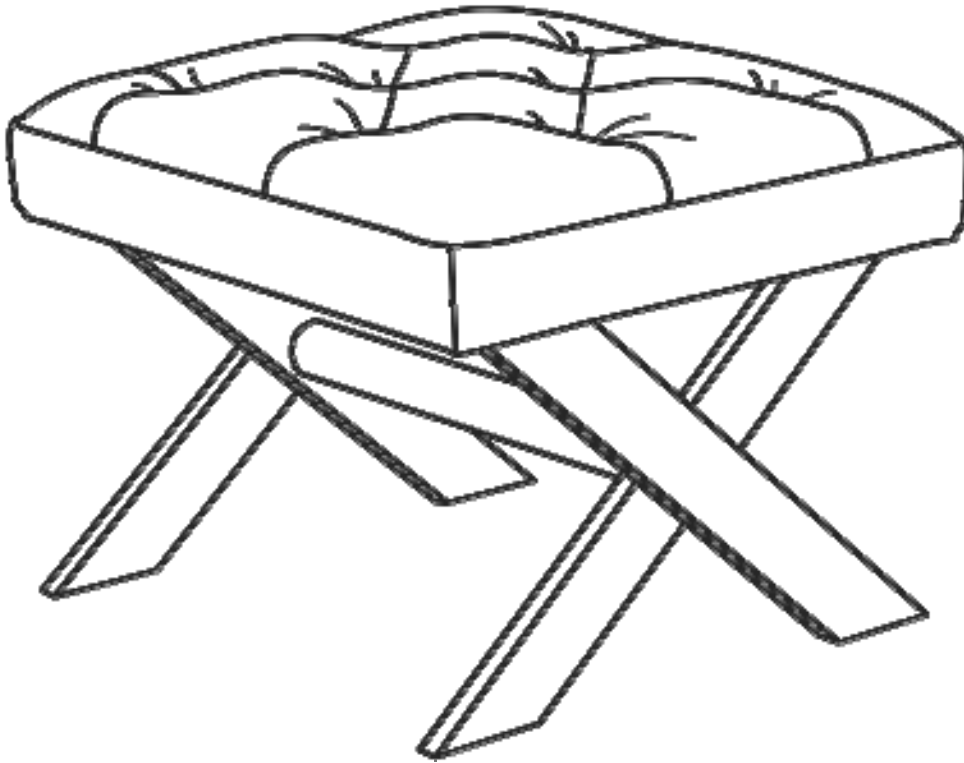

Assembly is completed. Your bench is ready to be enjoyed now!