

# Assembly Instructions

## Leg Console Table

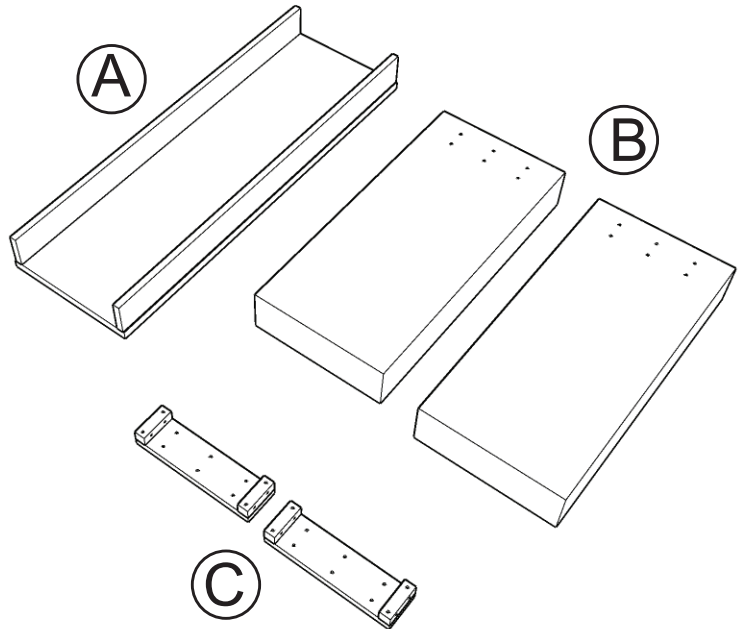
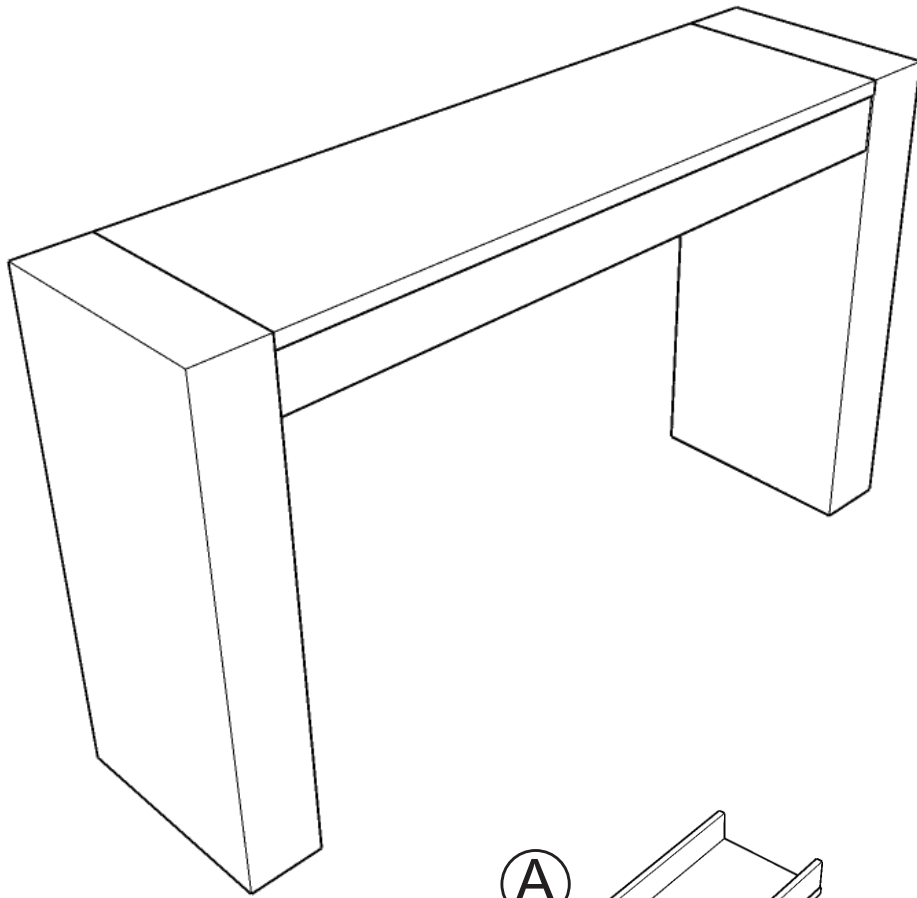

ITEM	DESCRIPTION	QUANTITY
A	Top panel	1
B	Legs	2
C	Side Aprons	2

hardware provided:



H1 X 8  
bolts M6 X 40mm



H2 X 12  
bolts M6 X 50mm



H3 X 20  
spring washers



H4 X 20  
flat washers



H5 X 1  
hex key

## Step 1

1. Place the Legs (B) with top surface facing up on the ground.
2. Insert six (6) H2 Bolts with six (6) H3 spring Washers and six (6) H4 flat washers then through the holes side apron (C) and into holes on Leg (B) (see picture), without tightening fully.
3. Tighten all bolts on side apron (B) with the H5 hex key.
4. Repeat step on another leg (B).

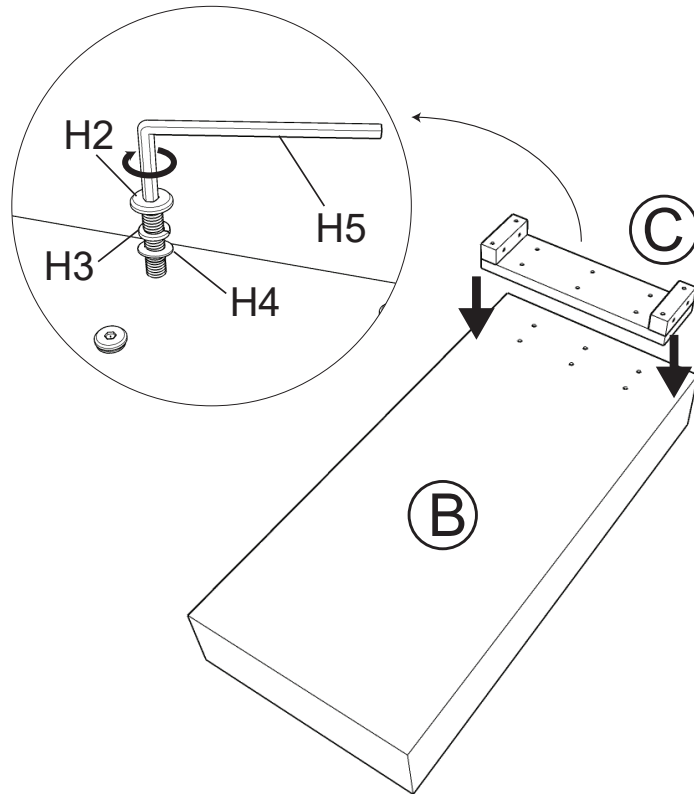

## Step 2

1. Place the Top Panel (A) with top surface facing up on the ground.
  2. Place left legs (B) in the space provided on bottom left side of top panel (A) (see picture).
- \* take note: all legs (B) can be left or right, can assemble fit in with top panel (A)

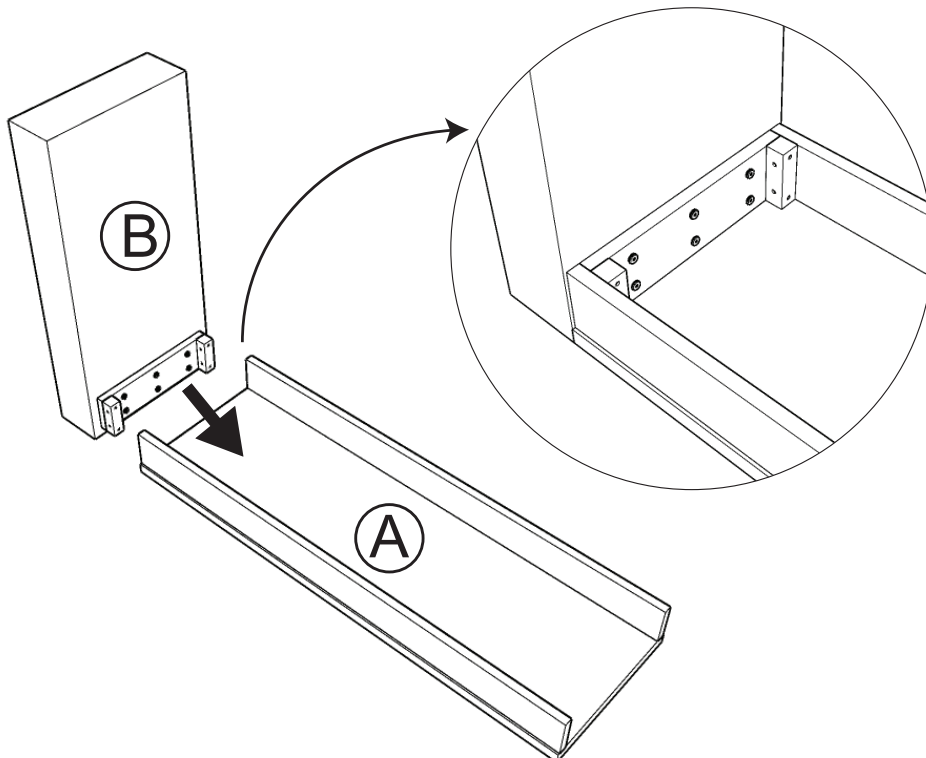

## Step 3

1. Insert two (2) H1 Bolts with two (2) H3 spring Washers and two (2) H4 flat washers then through the holes on the corner block apron of Top panel (A) and into holes on Leg (B) (see picture), without tightening fully.
2. Tighten all bolts on all legs (B) with the H5 hex key.

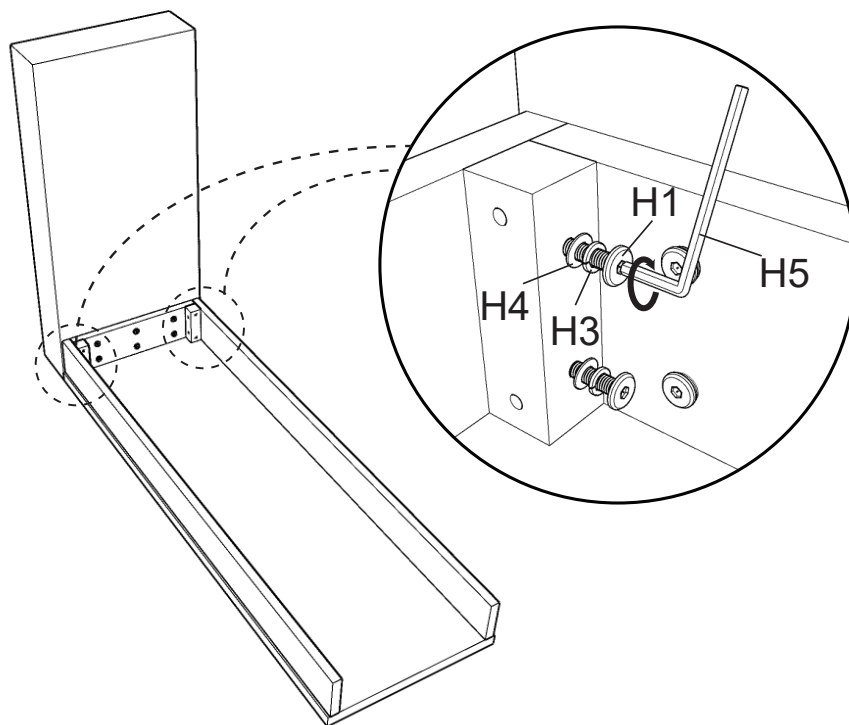

## Step 4

- Next Place right legs (B) in the space provided on bottom right side of top panel (A) (see picture).  
\* take note: all legs (B) can be left or right, can assemble fit in with top panel (A)

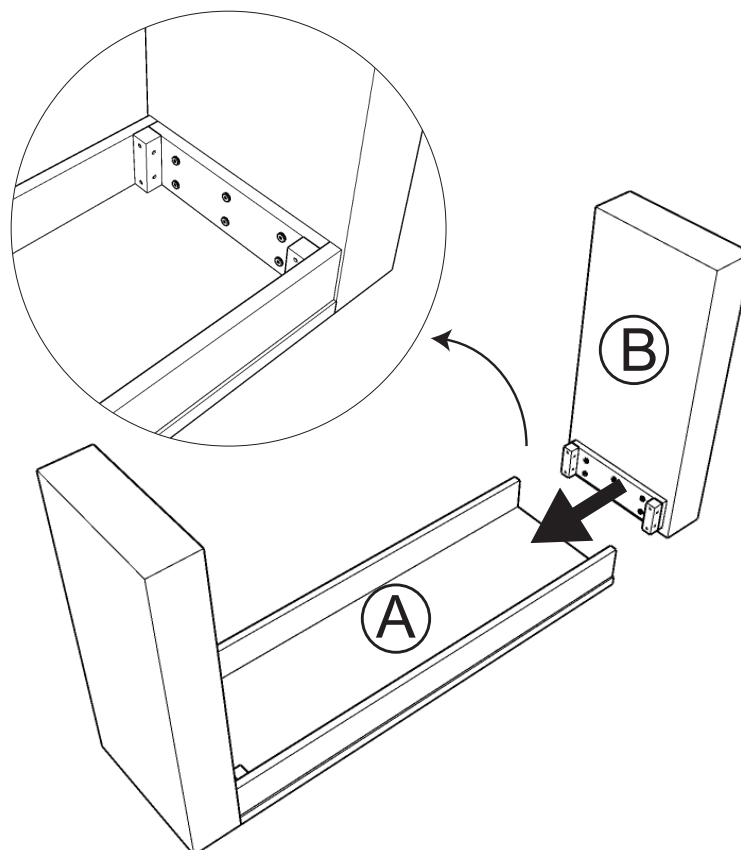

## Step 5

1. Insert two (2) H1Bolts with two (2) H3 spring Washers and two (2) H4 flat washers then through the holes on the corner block apron of Top panel (A) and into holes on Leg (B) (see picture), without tightening fully.
2. Tighten all bolts on all legs (B) with the H5 hex key.

