

ASSEMBLY INSTRUCTIONS

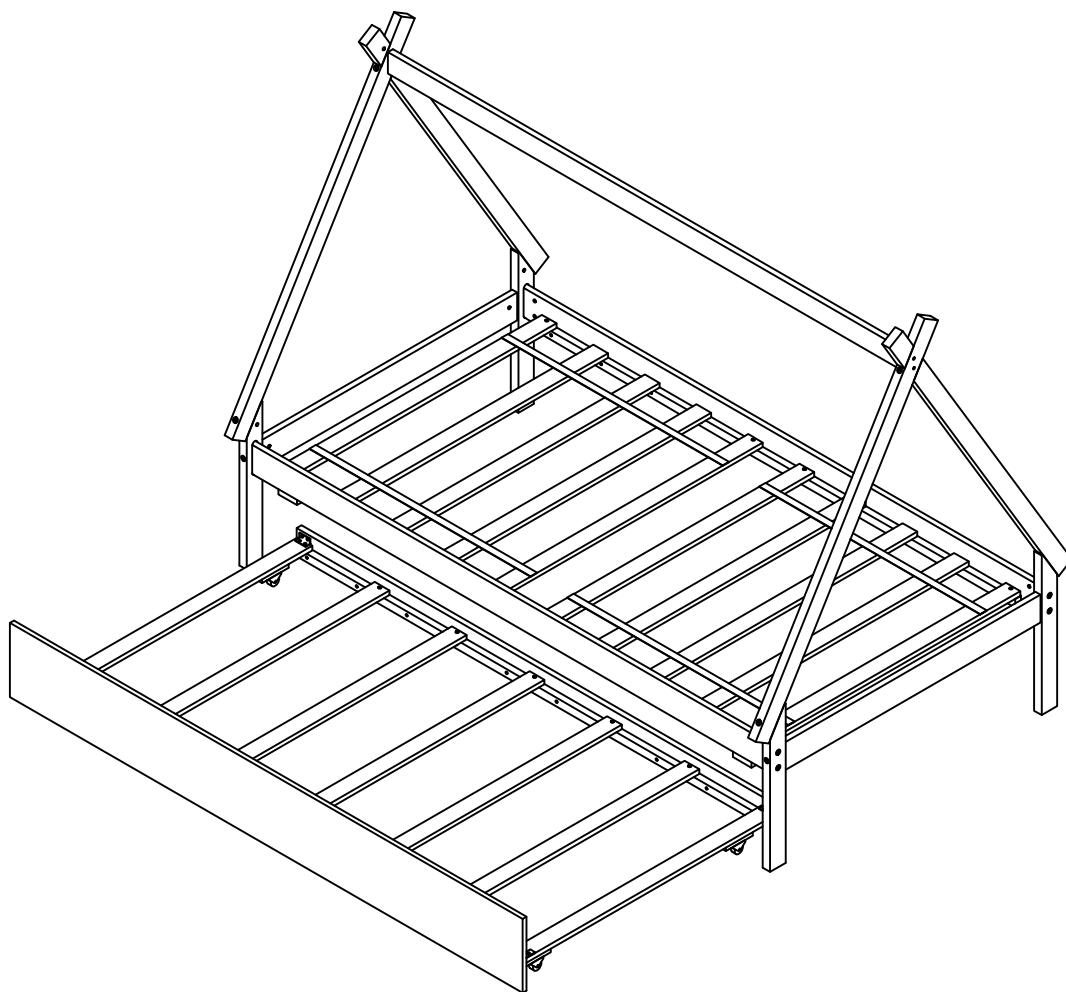

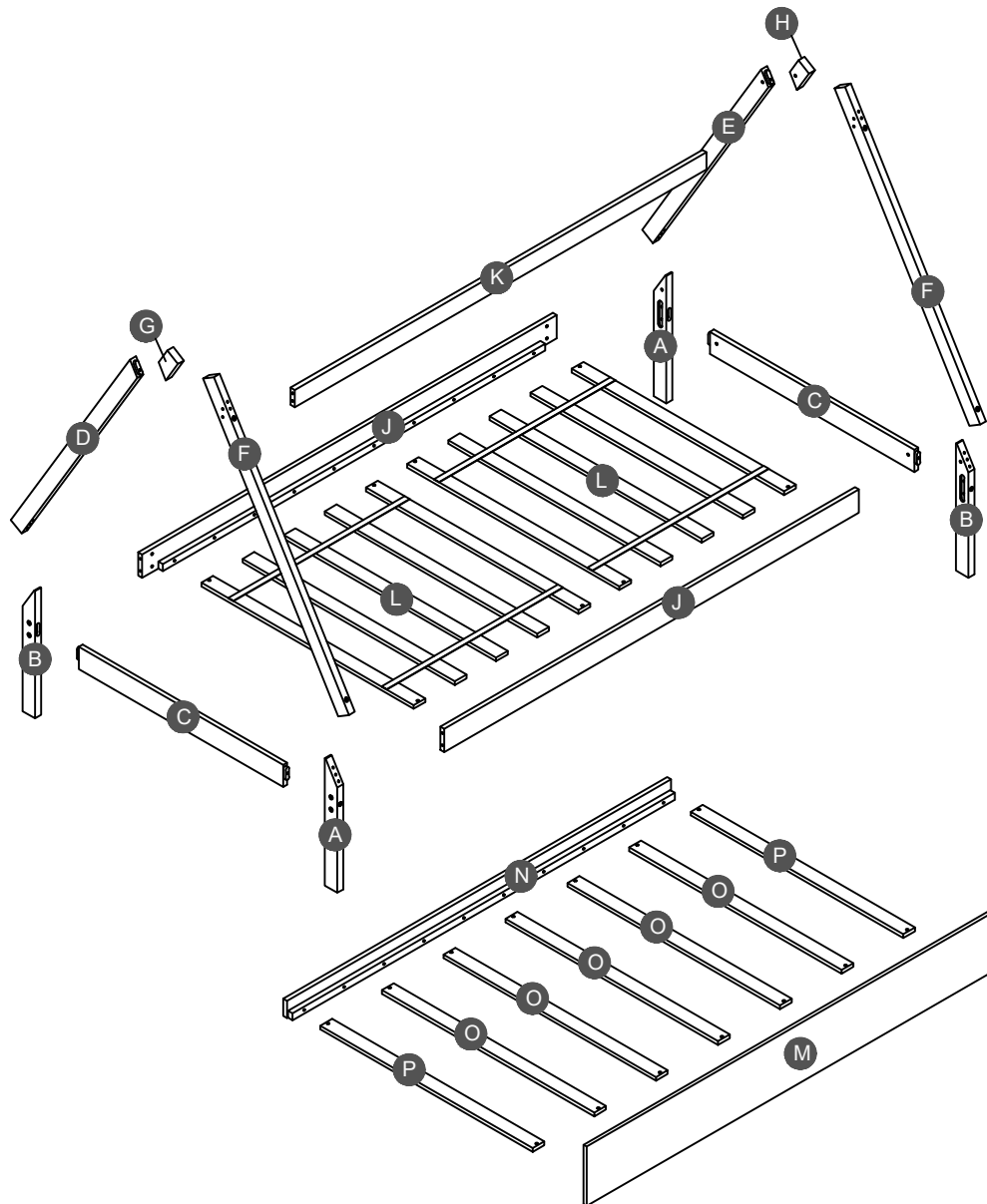



TWIN TENT BED WITH TRUNDLE



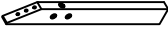
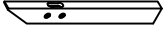
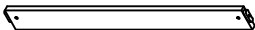
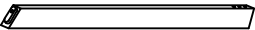
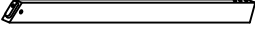
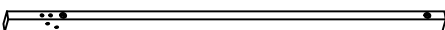

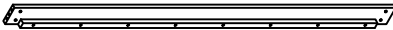
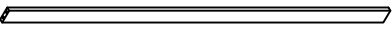
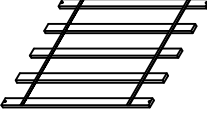





Detail View

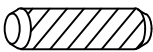
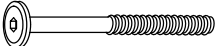
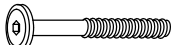

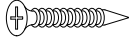
Part List

<p>A</p>  <p>Leg (Left front /Right back) - 2pcs</p>	<p>B</p>  <p>Leg (Left back/ Right front) - 2pcs</p>	<p>C</p>  <p>Horizontal bar (HB /FB) - 2pcs</p>
<p>D</p>  <p>Upper (Left back) - 1pc</p>	<p>E</p>  <p>Upper (Right back) - 1pc</p>	<p>F</p>  <p>Upper Front (Left /Right) - 2pcs</p>
<p>G</p>  <p>Left upper link - 1pc</p>	<p>H</p>  <p>Right upper link - 1pc</p>	<p>J</p>  <p>Side rail - 2pcs</p>
<p>K</p>  <p>Upper horizontal - 1pc</p>	<p>L</p>  <p>Slats - 2sets (5pcs/set)</p>	<p>M</p>  <p>Front panel of Trundle - 1pc</p>
<p>N</p>  <p>Back panel side rail of Trundle -1pc</p>	<p>O</p>  <p>Slats - 5pcs</p>	<p>P</p>  <p>Slats - 2pcs</p>

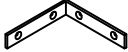
Hardware List

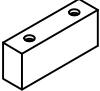
1  Ø8*30mm Wood dowel (10pcs)	2  (Ø15)1/4"*100mm Hex-Head bolts (4pcs)	3  (Ø15)1/4"*80mm Hex-Head bolts (20pcs)
4  1/4"*15 (9.5mm) Horizontal-Hole bolts (24pcs)	5  Ø4*30mm Wood screws (34pcs)	6  (1/4")4.5*58mm Allen key (1pc)
7  100*63*20mm Wheels (4pcs)	8  40*18*18*2mm Metal bracket (2pcs)	9  95*95*18*3mm Metal bracket (2pcs)
10  Ø3.5*15mm Wood screws (16pcs)	11  70*35*19mm Trundle stopper (2pcs)	

ASSEMBLY TOOLS REQUIRED (NOT INCLUDED)

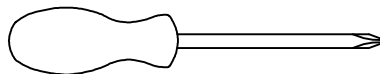

PLEASE BE CAREFUL DO NOT DAMAGE THE HOLE POSITION WHEN YOU USE POWER TOOLS !

STEP 1:

1		2		3	
	2PCS		2PCS		1PC
			4		
				3PCS	

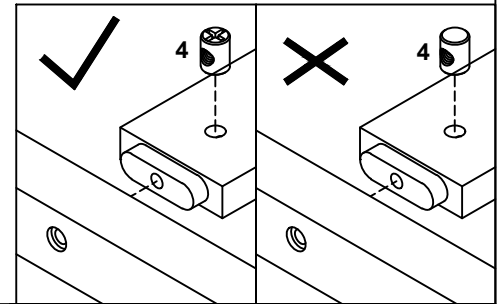
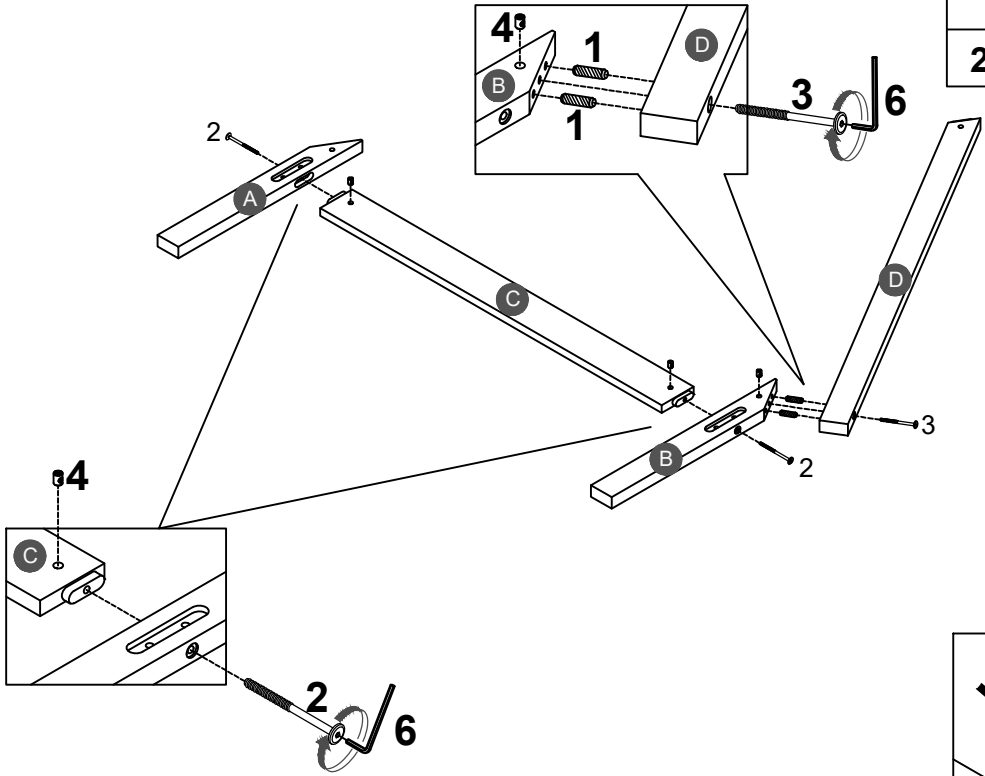

Note: Part 4 will face up with the "x" mark on it, otherwise it cannot be tightened

STEP 2:

1		3		4	
	2PCS		2PCS		2PCS

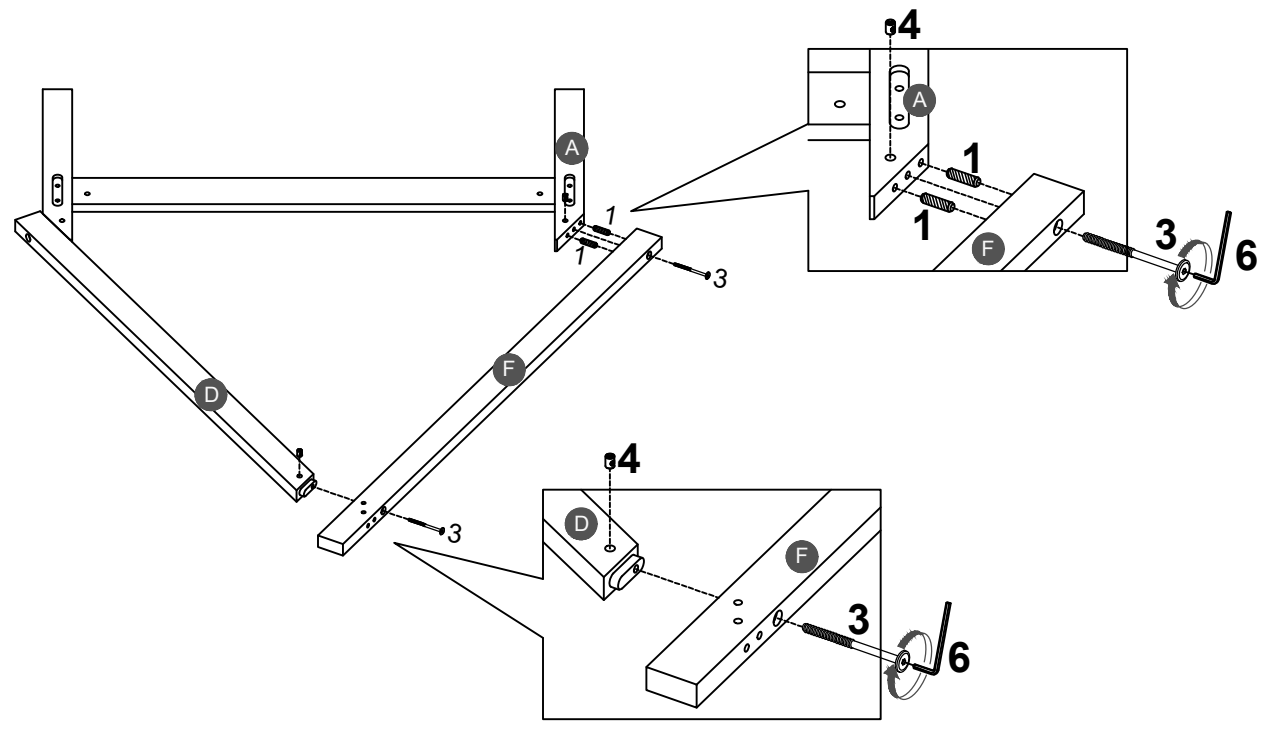

STEP 3:

1		3		4	
1PC		1PC		1PC	

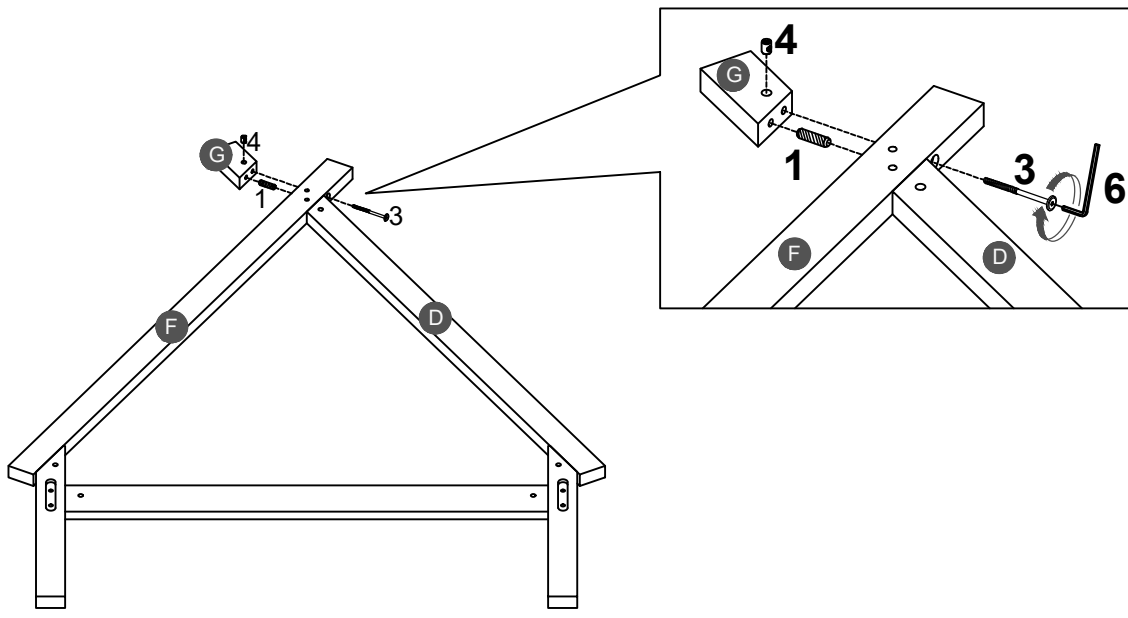

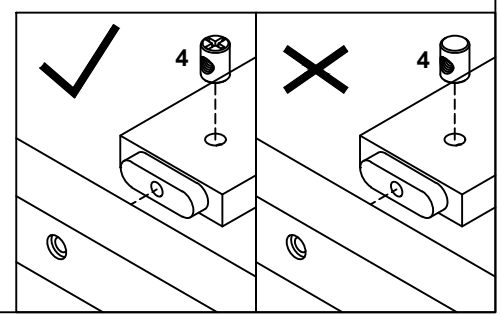
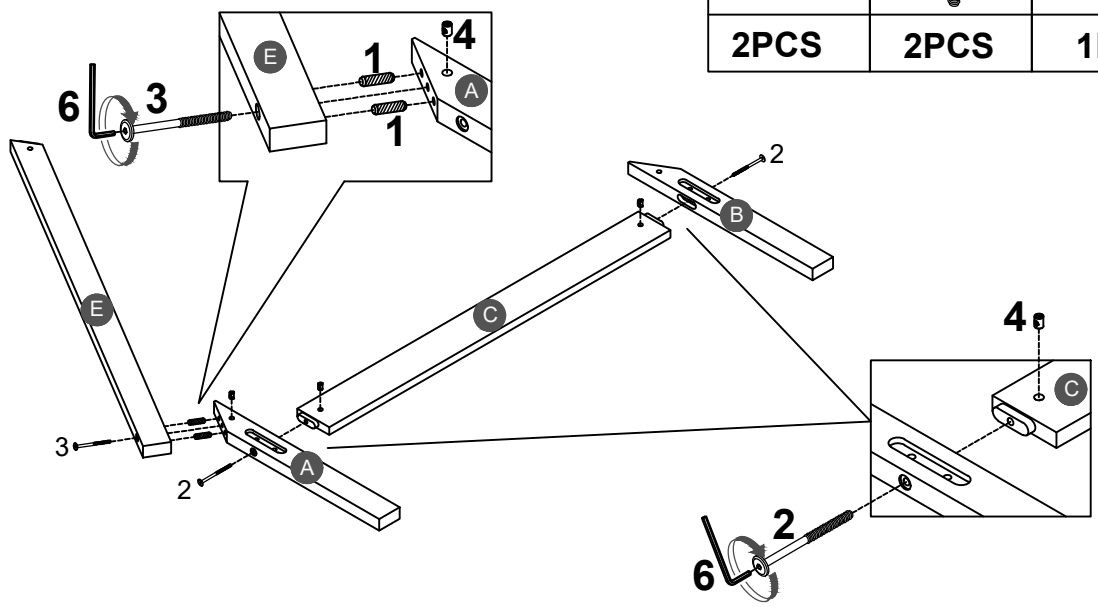

STEP 4:

1		2		3		4	
2PCS		2PCS		1PC		3PCS	



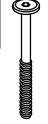

Note: Part 4 will face up with the "x" mark on it, otherwise it cannot be tightened

STEP 5:

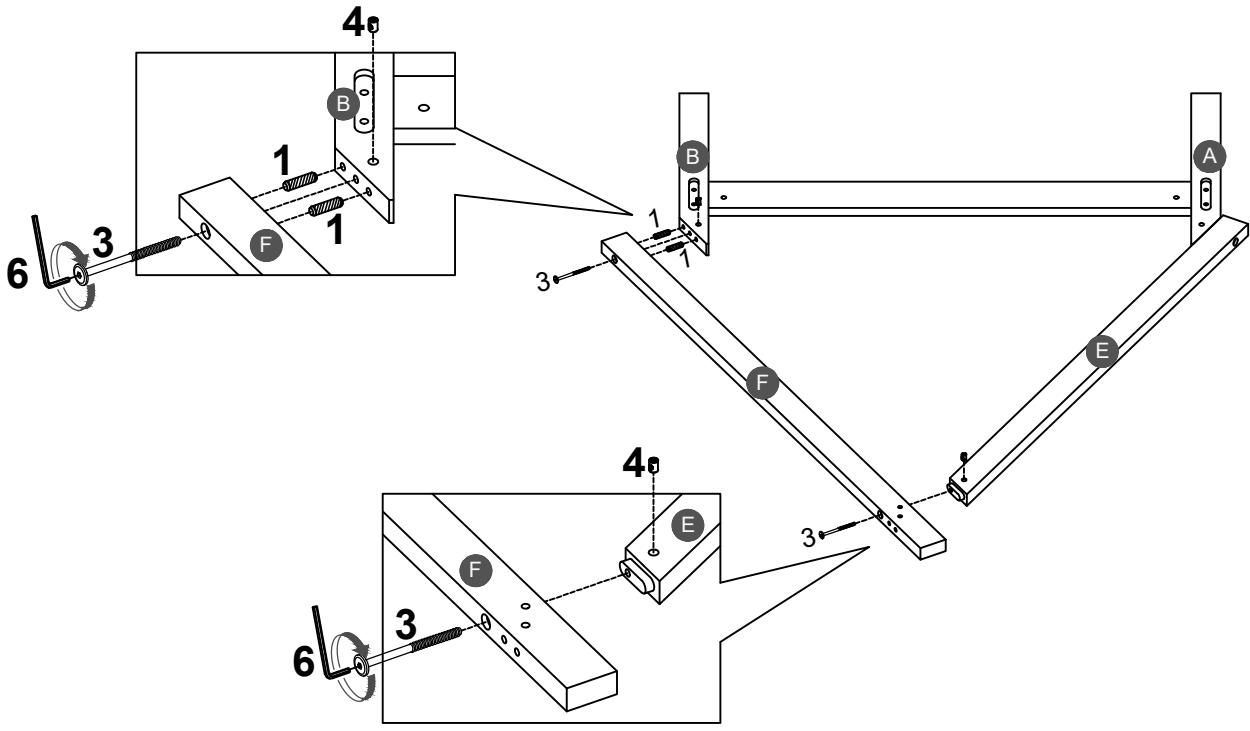
1		3		4	
2PCS		2PCS		2PCS	



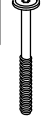

STEP 6:

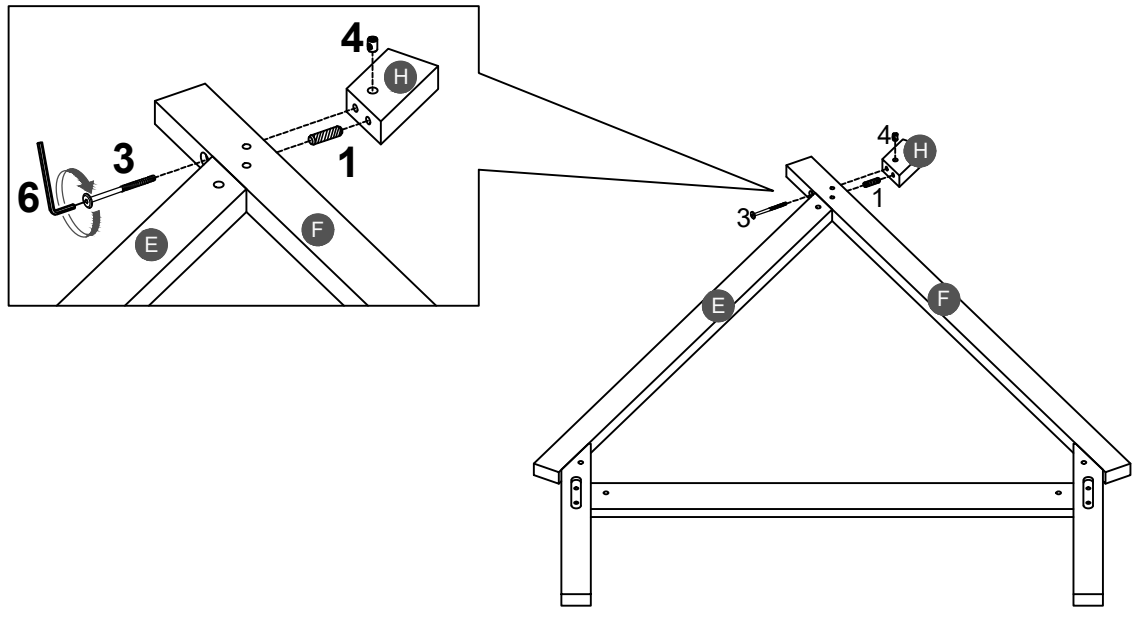
1		3		4	
1PC		1PC		1PC	



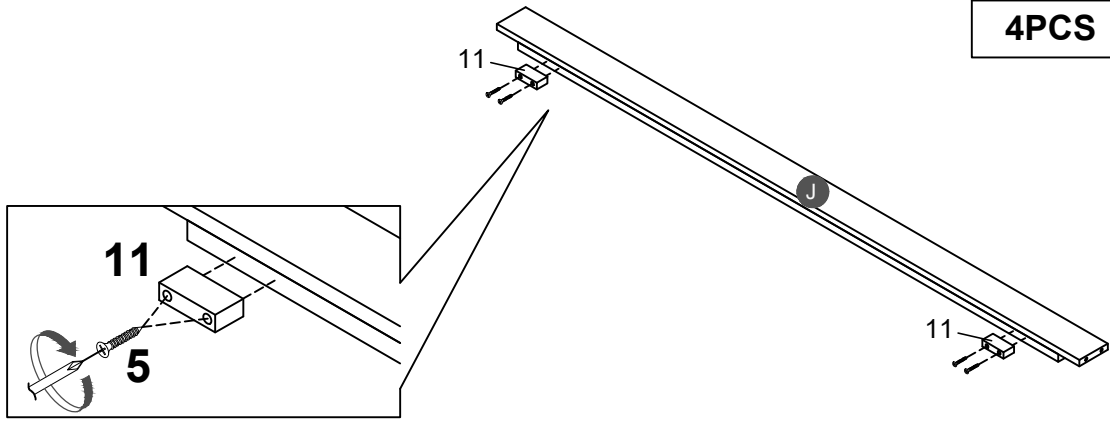

STEP 7:

5 	11 
4PCS	2PCS



Trundle stopper (11) with lower side rail front (J) by using screw (5).

STEP 8:

3 	4 
12PCS	12PCS

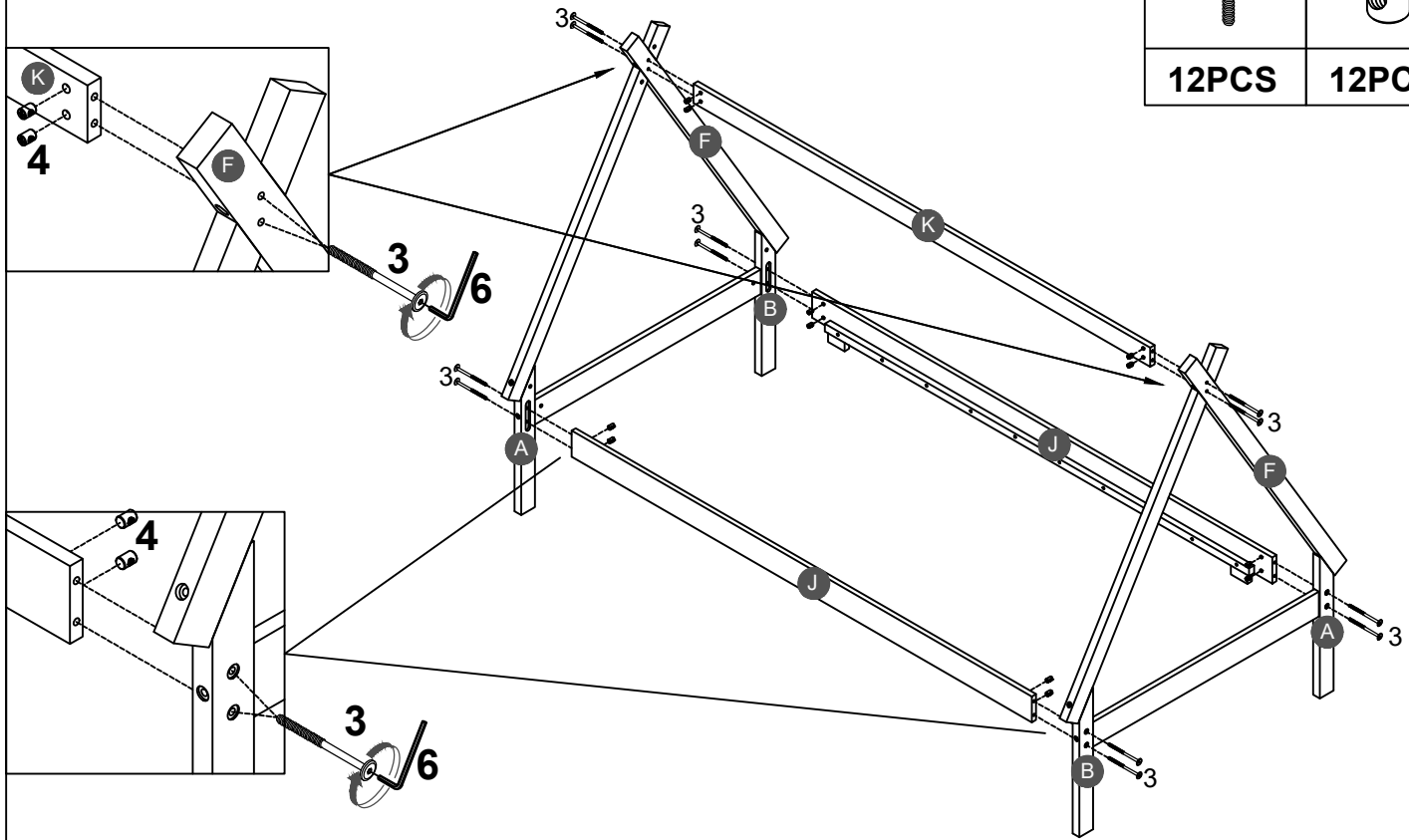

STEP 9:

5



8PCS

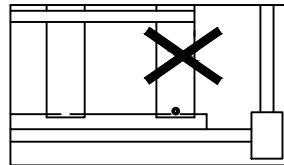
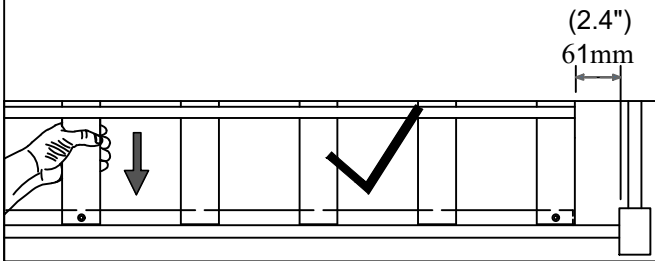
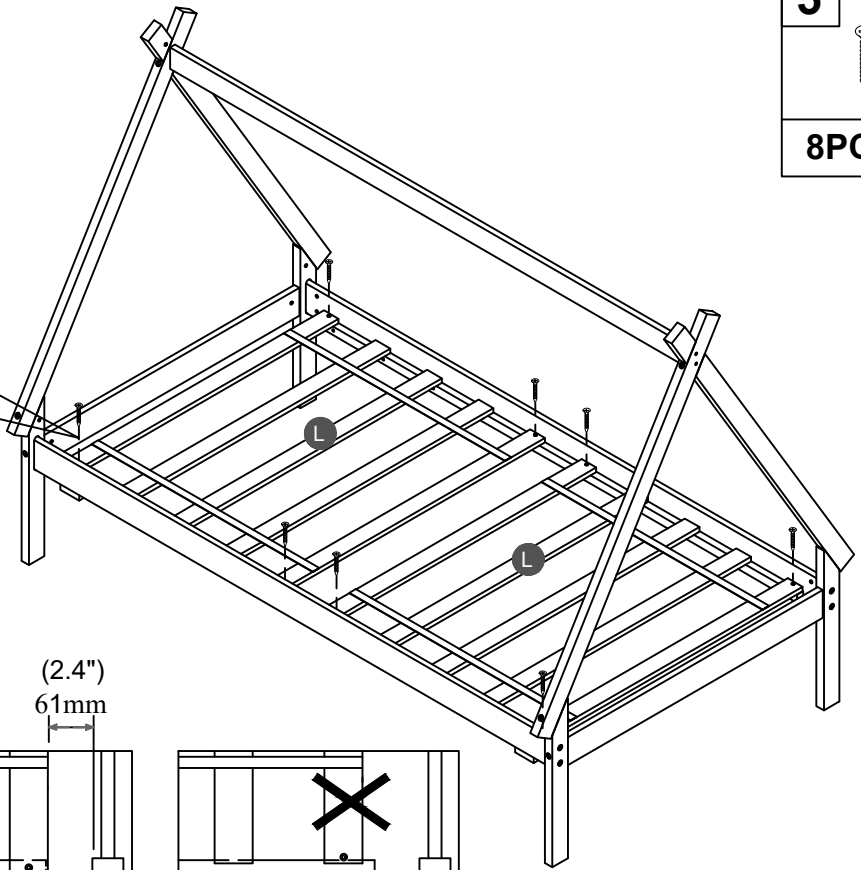
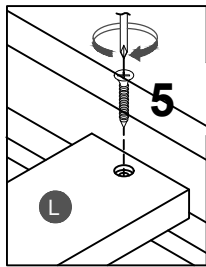

Note: Do not lock the screws of the bed slats to the outermost edge of the bed slats, you need to leave a certain space at the edges, otherwise it will cause the board to break. Do not lock the bed slats on the edge of the wood, please hold firmly before screwing, hold it in place with one hand, then lock the screw.

STEP 10:

5



8PCS

7



4PCS

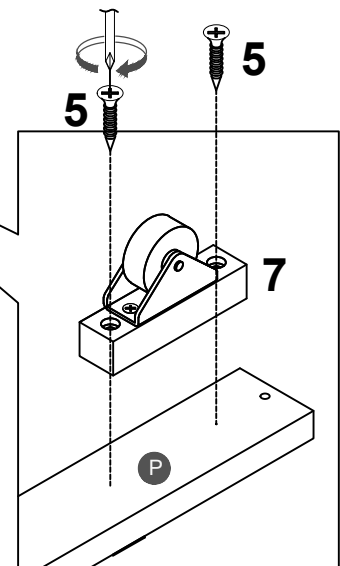
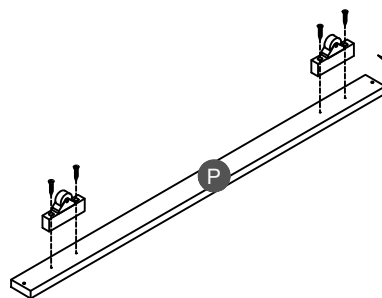
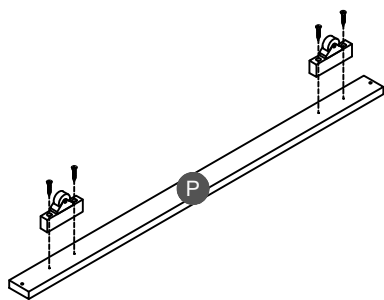

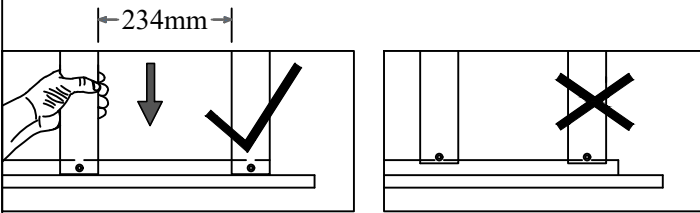
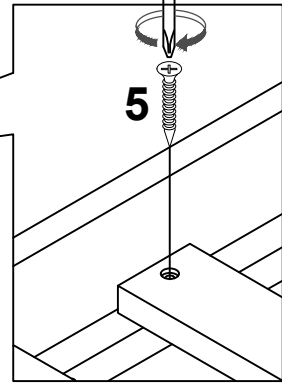
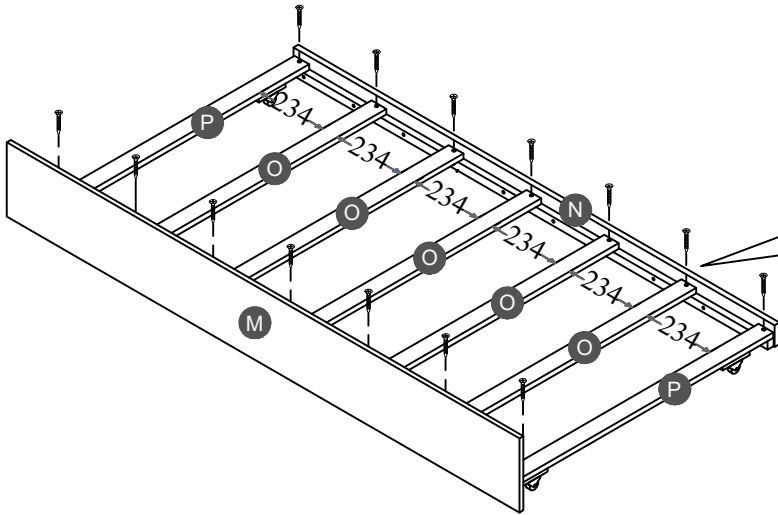

STEP 11:

5	
14PCS	

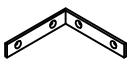

Note: Do not lock the screws of the bed slats to the outermost edge of the bed slats, you need to leave a certain space at the edges, otherwise it will cause the board to break.
Do not lock the bed slats on the edge of the wood, please hold firmly before screwing, hold it in place with one hand, then lock the screw.

STEP 12:

9	10
	
2PCS	8PCS

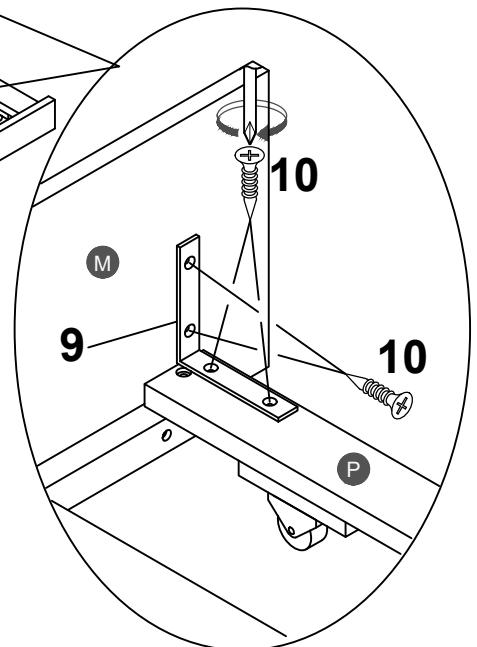
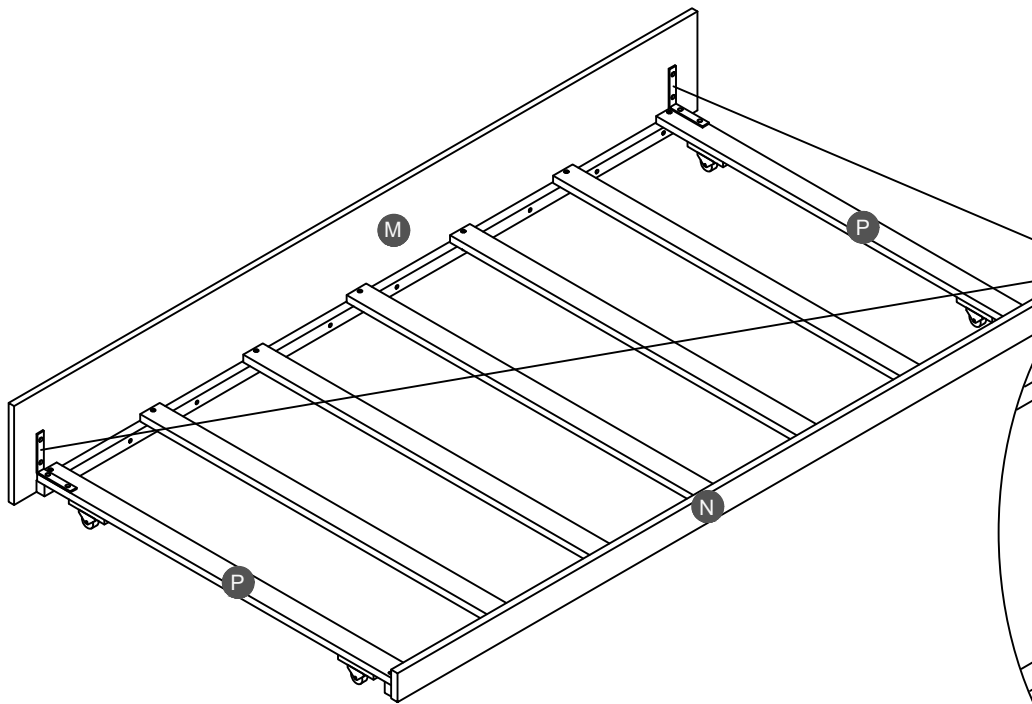

STEP 13:

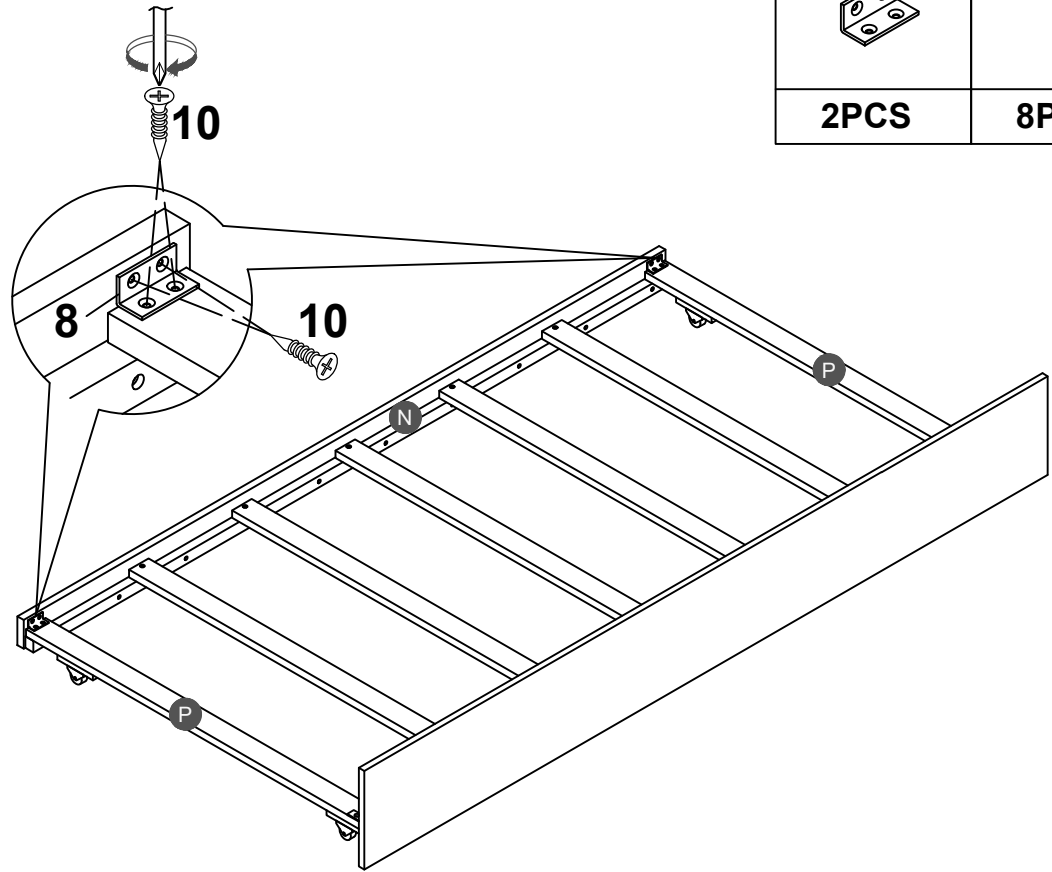

8



2PCS

10



8PCS

STEP 14:

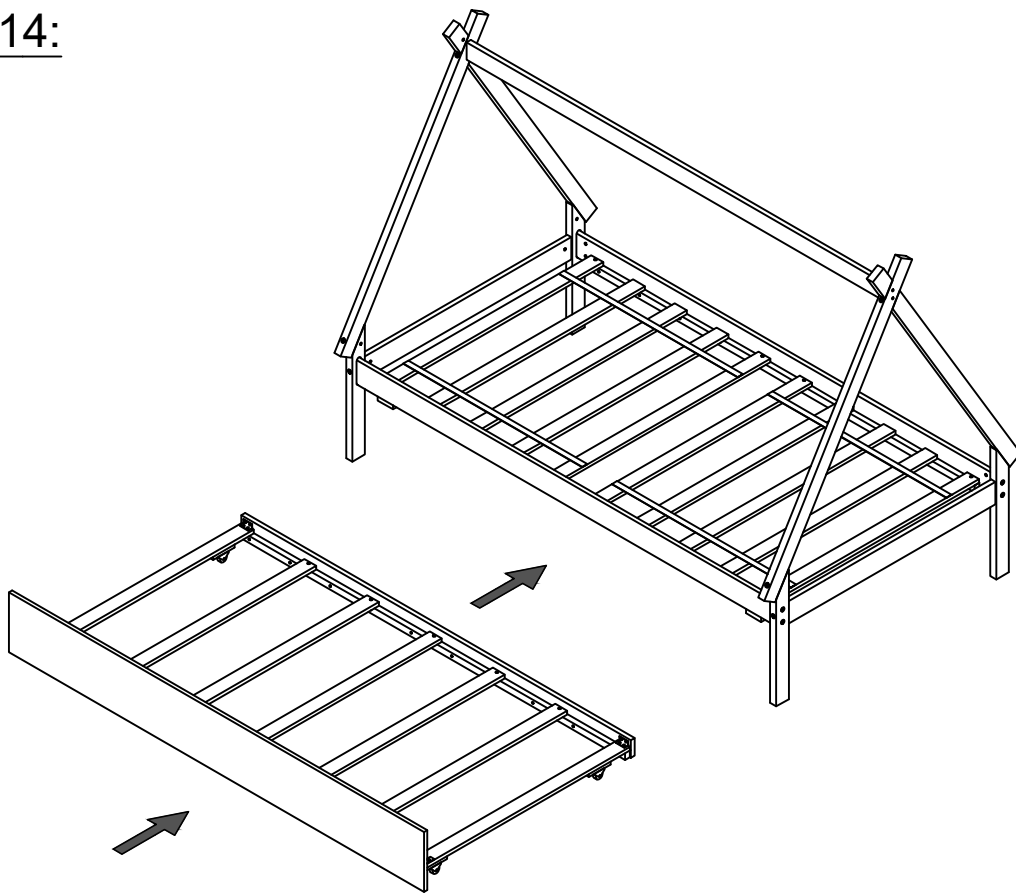

Push Trundle and Drawer under the bottom of Bunkbed.