

ADIRONDACK CHAIR

Assembly Instruction



Read before you start: This assembly takes about 20 mins/person, an electric screwdriver is highly recommended. Do not screw too tight until you finish the last step.

Part List:

<p>AL AR</p> <p>Left and Right Armrest</p>	<p>BR BL</p> <p>Left and Right Leg</p>	<p>C</p> <p>Back Panels 7pcs</p>	<p>D</p> <p>D1 UP D2 CENTRE D3 DOWN</p>			
<p>E</p> <p>Left and Right SeatBase Leg</p>	<p>F 2pcs</p>	<p>G 1pc</p>	<p>H 5pcs</p> <p>Seat Panels</p>			
<p>I 1pc</p>		<p>J 1pc</p>	<p>K 1pc</p>			
<p>① 8*50mm 4sets</p>	<p>② 6*55mm 2sets</p>	<p>③ 4*35mm 47pcs</p>	<p>④ 6*40mm 4pcs</p>	<p>⑤ 4*45mm 2pcs</p>	<p>1pc</p>	<p>1pc</p>

Step 1: Install the Seat

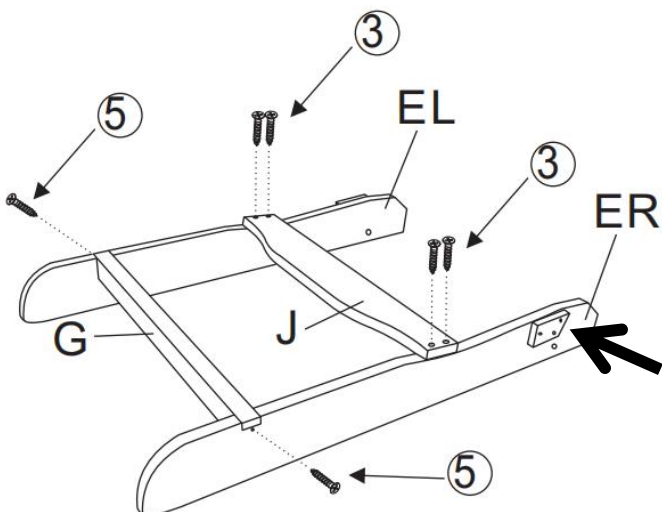

1. Attach G and J to EL and ER (Left and right cannot be interchanged, check the arrow)

③ = 4pcs
⑤ = 2pcs

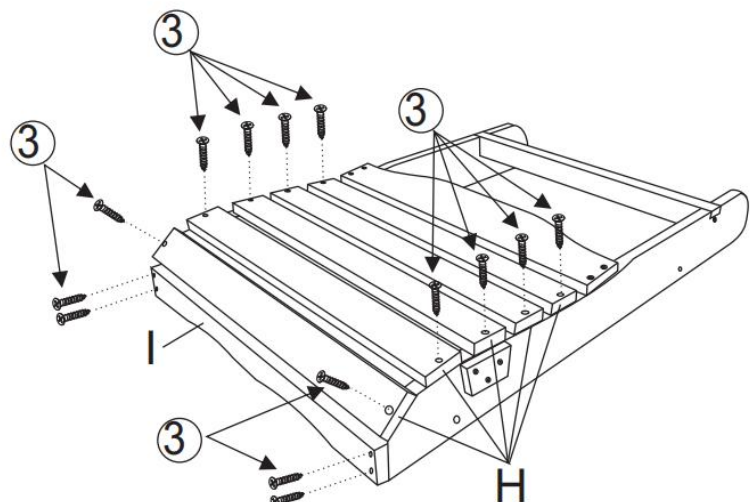

2. Attach part I, then follow the positioning mark to attach 5 seat panels H

③ = 14pcs

Step 2: Install the Back

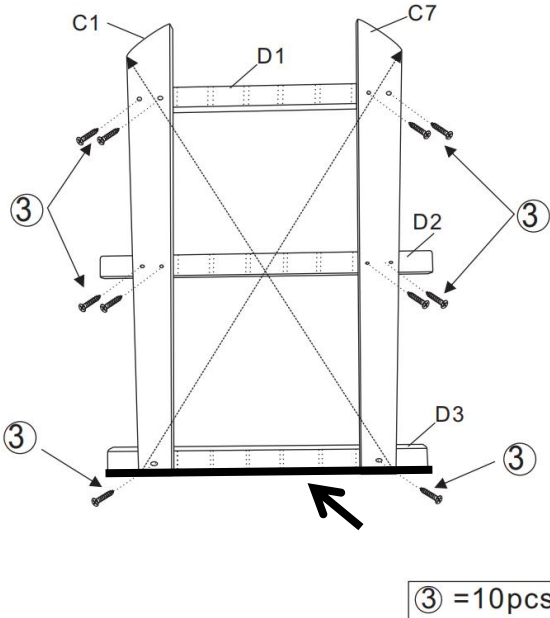

1. Attach C1 and C7 to D1, D2, and D3 (make sure the bottom of C1 - C7 are on a horizontal line, check the arrow)

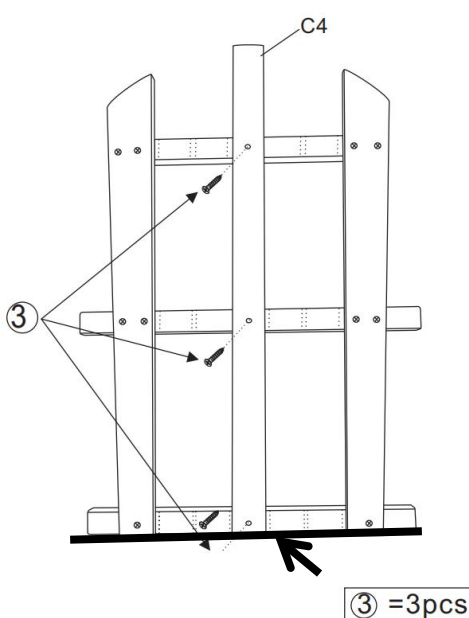

2. Attach the middle back panel C4

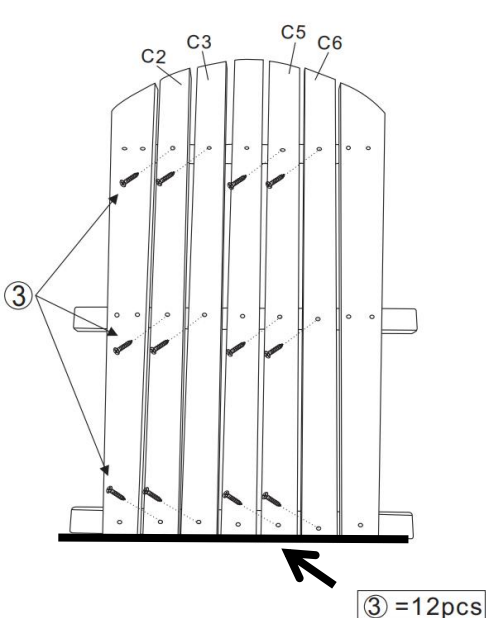

3. Attach the rest back panels C2, C3, C5, C6

Step 3: Install the Legs

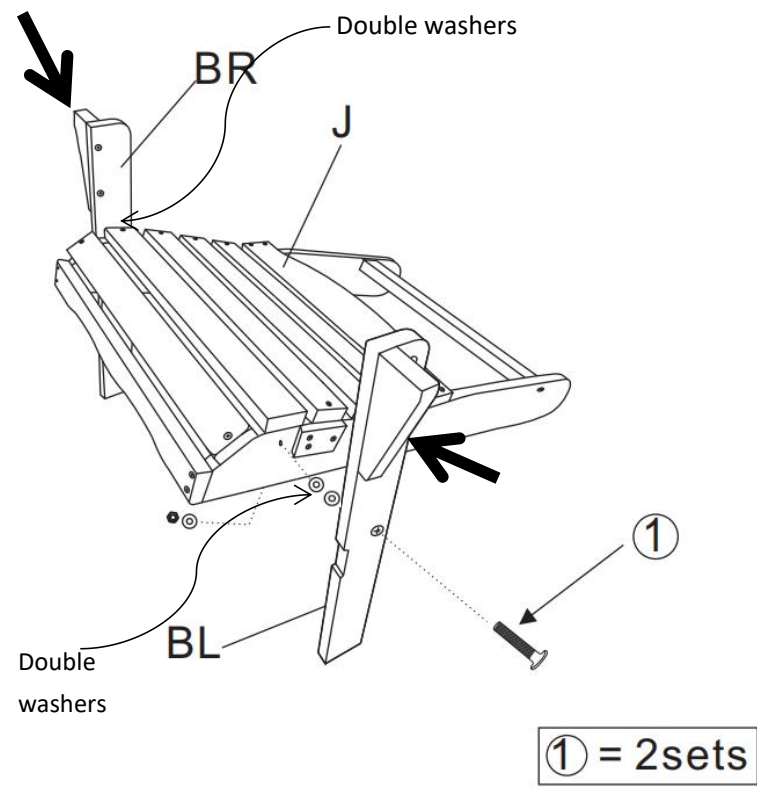

1. Attach BR and BL to the seat (Left and right cannot be interchanged, check the arrow)

Step 4: Install the Arms

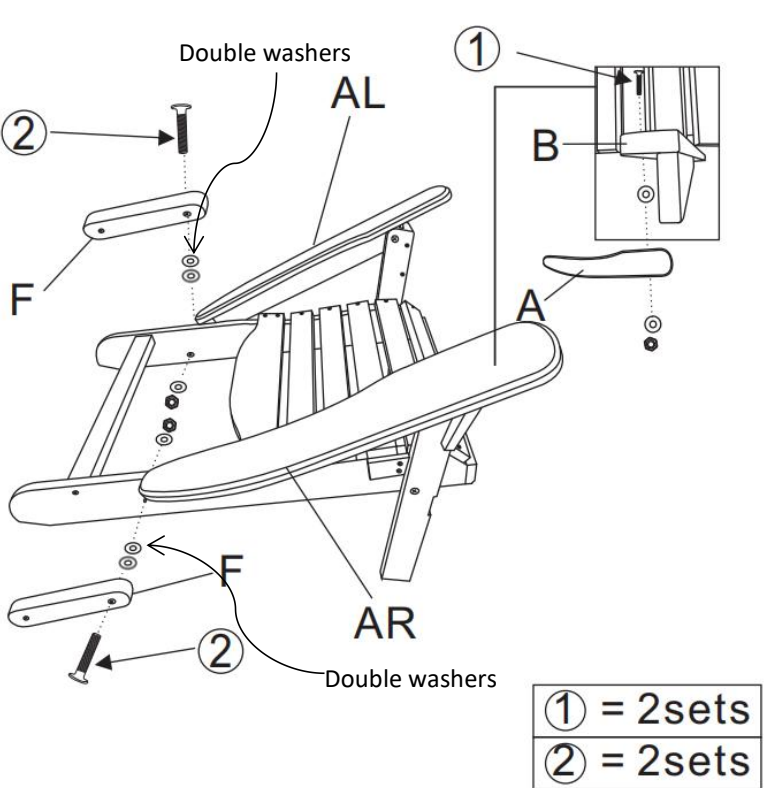

1. Attach AR and AL to the legs (Left and right cannot be interchanged)
 2. Attach part F to the both side of the seat

IMPORTANT: We suggest to use double washers in between the wood for easier folding feature.

Step 5: Connect the Back

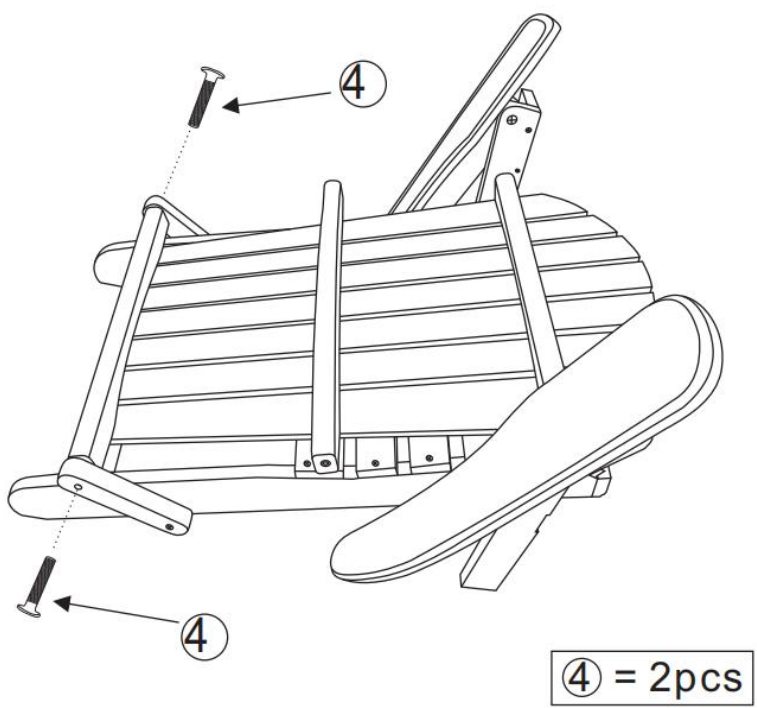

1. Connect the finished back to part F

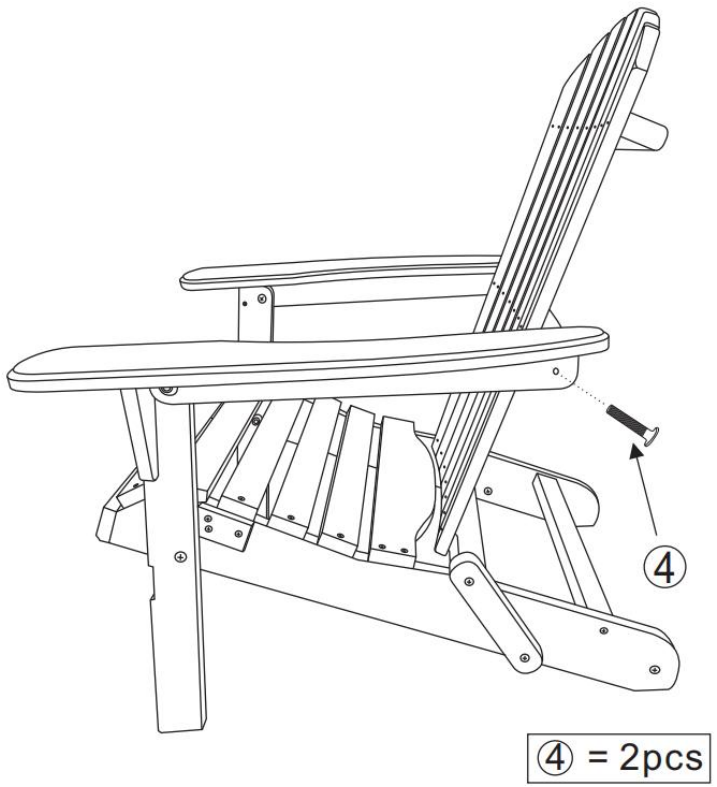

2. Connect the arms to the back

Step 6: Finish the Look!

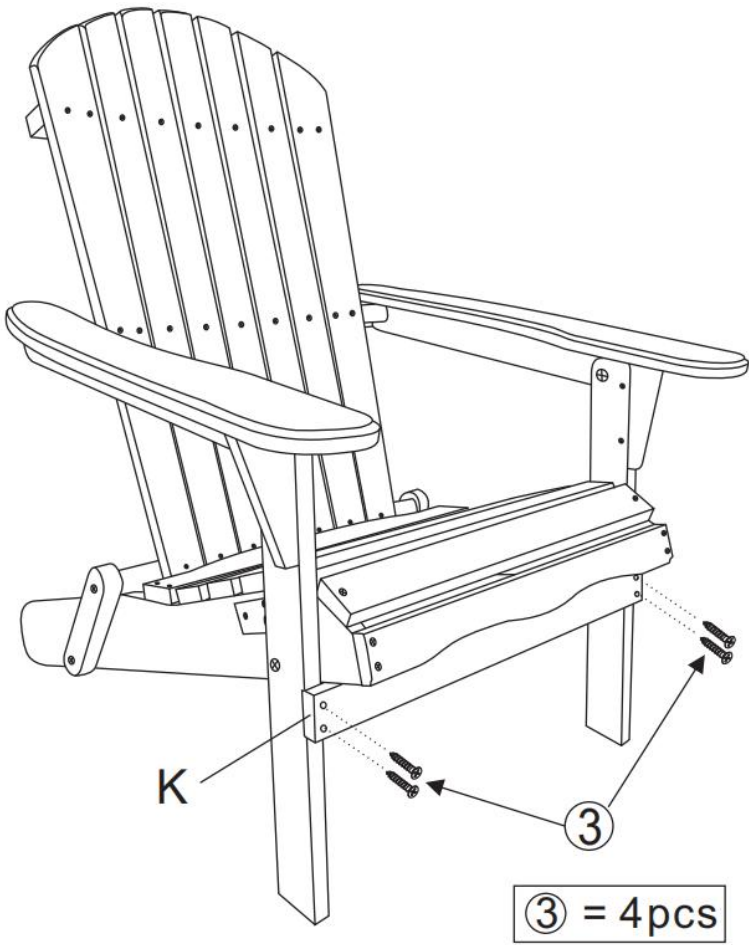

1. Attach part K, done!
Check the overall condition before you tighten all the screws, we hope you enjoy the chair!