

ASSEMBLY INSTRUCTIONS

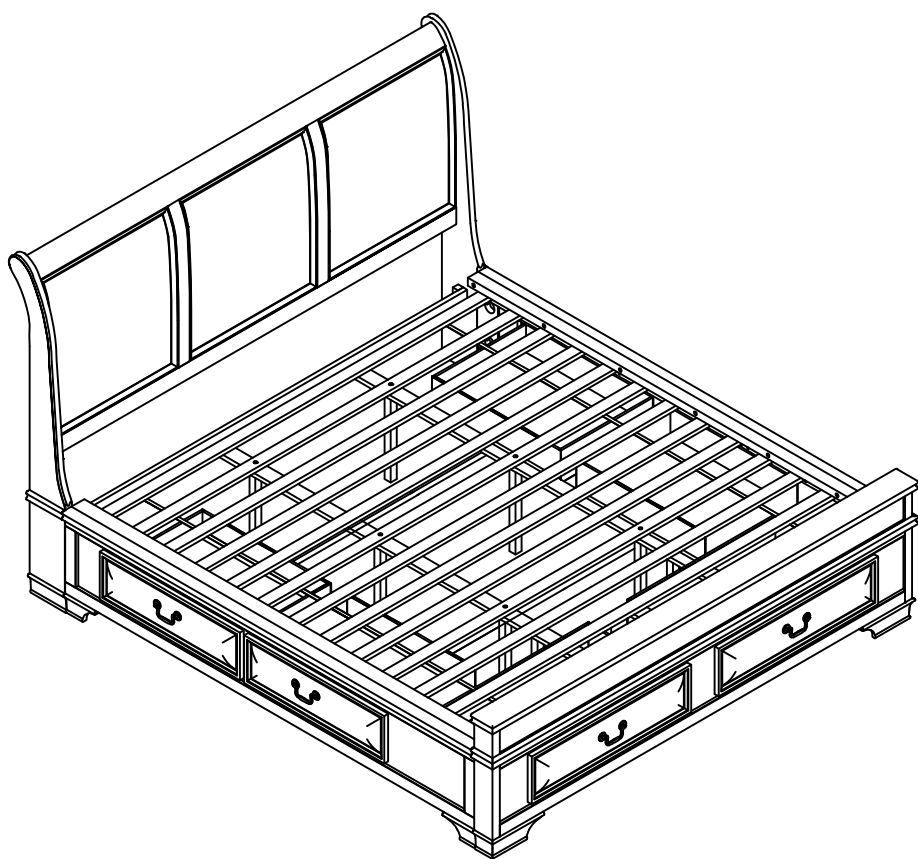

TOOLS REQUIRED

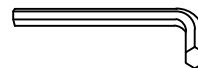

Allen Wrench

(Included)



Phillips
Screwdriver

(Not Included)



3- People
Recommended

ASSEMBLY RATING



EASY —————> DIFFICULT

The Assembly Rating is a 5-point system showing the level of effort needed to assemble a specific product.

CAL.KING BED

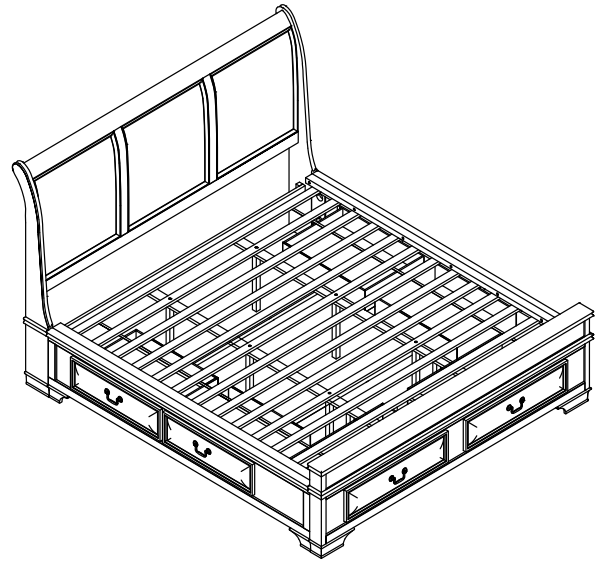
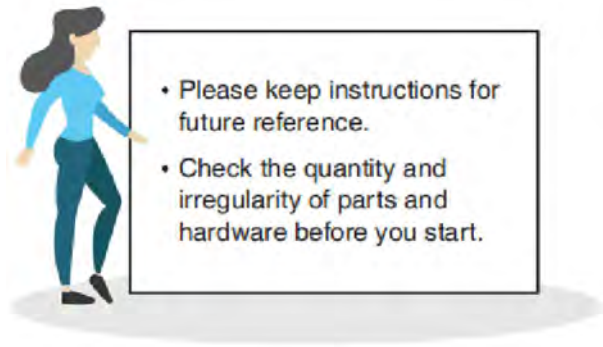

PARTS

#1 1pc

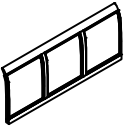

Headboard Panel

#2 2pcs



Headboard Leg (L&R)

#3 1pc



Headboard Support

#4 1pc

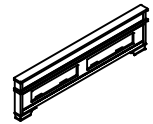

Storage Footboard

#5 1pc

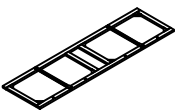

Bottom Frame for drawer of Footboard

#6 2pcs

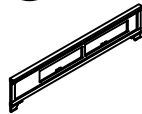

Side Rail (L&R)

#7 2pcs



Rail Drawer Support Slat

#8 2pcs

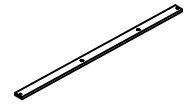

Center Slat

#9 4pcs



Drawer for Side rail

#10 2pcs

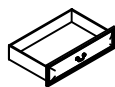

Drawer for Footboard

#11 6pcs

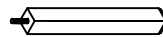

Long support leg
362x29x29mm

#12 2pcs

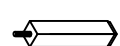

Short support leg
145x29x29mm

#13 2pcs



Storage Support Leg
195x29x29mm

#14 1pc



Bed Slat (13pcs)

#15 2pcs

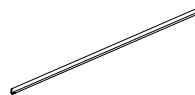

Top Side Rail

HARDWARE

#A 8pcs



Bolt Ø5/16" x 1-3/4"

#E 4pcs



Flat Washer Ø1/4"

#J 8pcs



Threaded Stud
Ø5/16"x3-1/2"

#B 8pcs

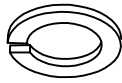

Lock Washer Ø5/16"

#F 1pc



Allen Wrench M4

#K 8pcs



Half Moon Ø5/16"

#C 8pcs

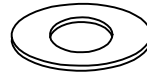

Flat Washer Ø5/16"

#G 4pcs



Wooden Dowel 10*40mm

#L 8pcs



Hex nut Ø5/16"

#D 14pcs



Bolt Ø1/4" x 1-1/2"

#H 30pcs

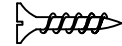





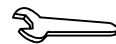

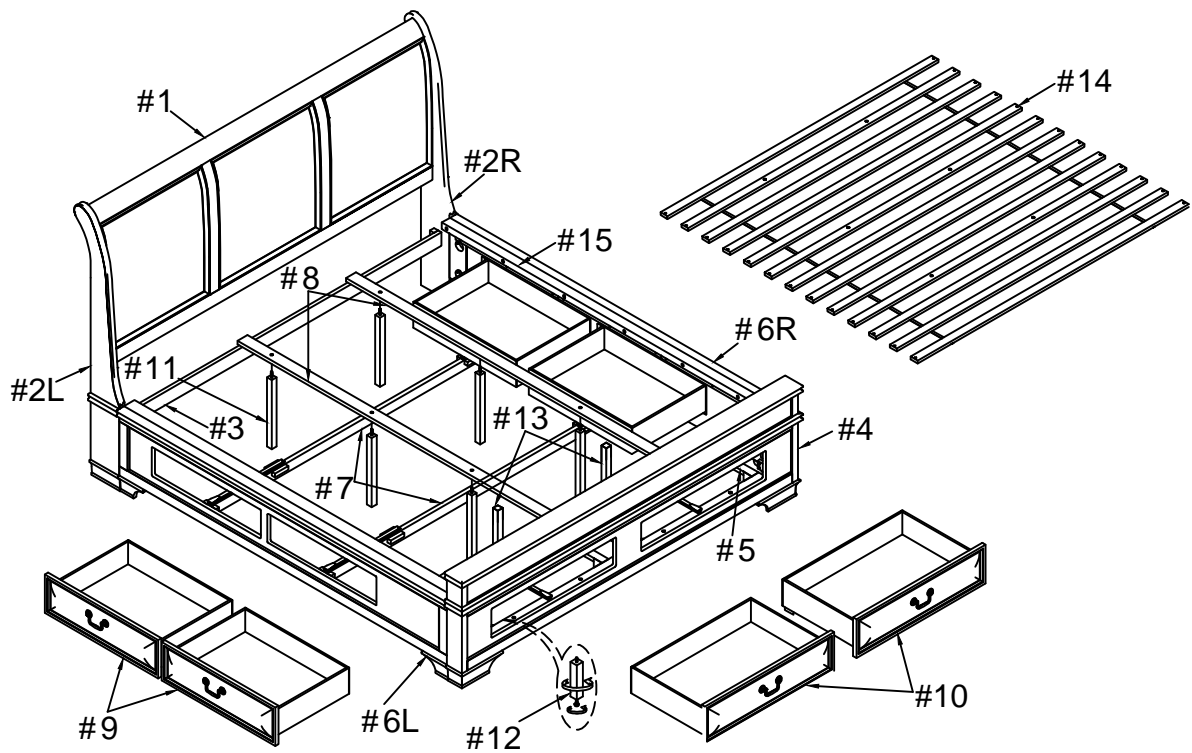

Screw #8 x 32mm

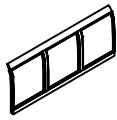
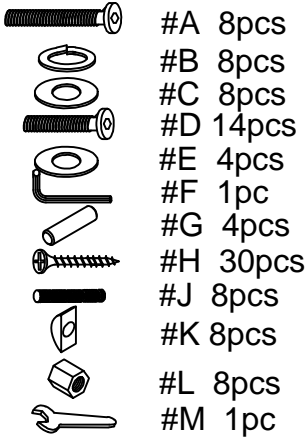
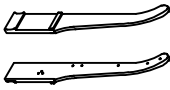
#M 1pc

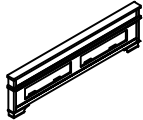
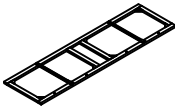

Wrench

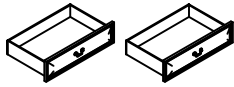
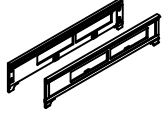

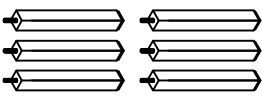
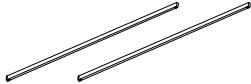
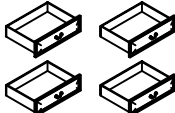
Carton	Disignation	Part		Hardware
1	Headboard	#1		
	Headboard Leg(L&R)	#2		
	Headboard Support	#3		
2	Footboard	#4		
	Bottom Frame for drawer of Footboard	#5		
	Short support leg	#12		
	Storage Support Leg	#13		
	Bed Slat	#14		
3	Drawer for Footboard	#10		
4	Side Rail (L&R)	#6		
	Rail Drawer Support Slat	#7		
	Center Slat	#8		
	Long support leg	#11		
	Top Side Rail	#15		
5	Drawer for Side rail	#9		

ASSEMBLY INSTRUCTIONS

1

- Part #1 x1pc
- Part #2 x2pcs
- Part #3 x1pc
- Hardware #A x8pcs
- Hardware #B x8pcs
- Hardware #C x8pcs
- Hardware #G x4pcs

Prepare 8 bolts assembly by inserting lock washer (#B) then flat washer (#C) onto bolts (#A). Attach dowels (#G) to the holes of the HB legs (#2R/L), then align HB legs (#2R/L) to the HB panel (#1) and HB support (#3). Secure by using bolts (#A).

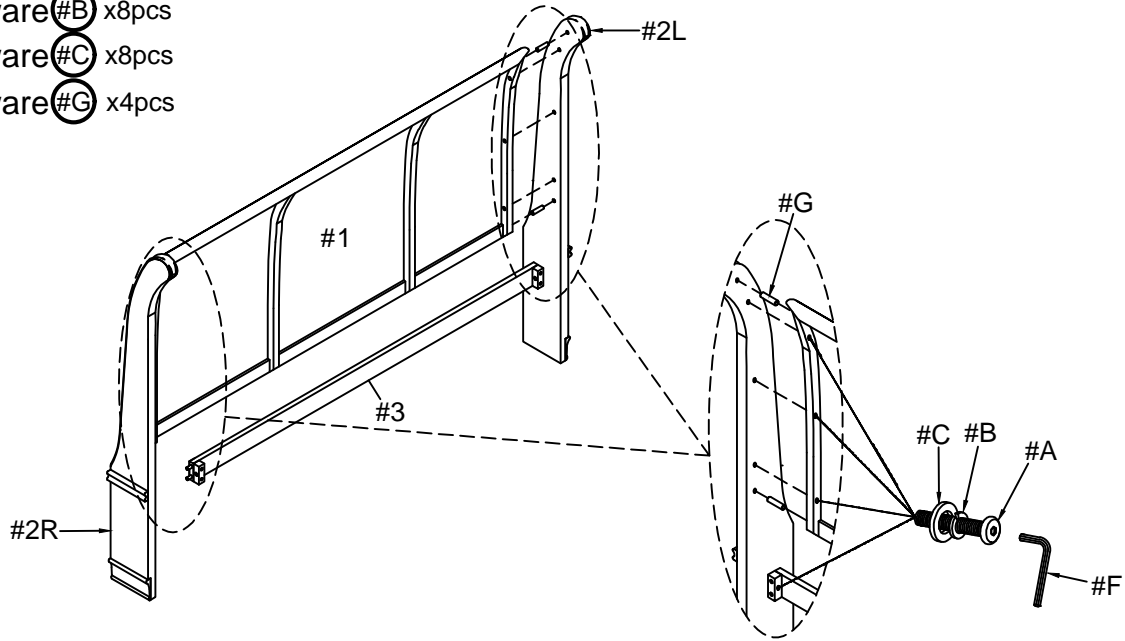

2

- Part #4 x1pc
- Part #5 x1pc
- Part #12 x2pcs
- Part #13 x2pcs
- Hardware #D x4pcs
- Hardware #E x4pcs

2) Attach support legs (#13) to the holes of the bottom frame (#5).

1) Align bottom frame (#5) to the holes of the footboard (#4), then secure by using bolts (#D) with washers (#E).

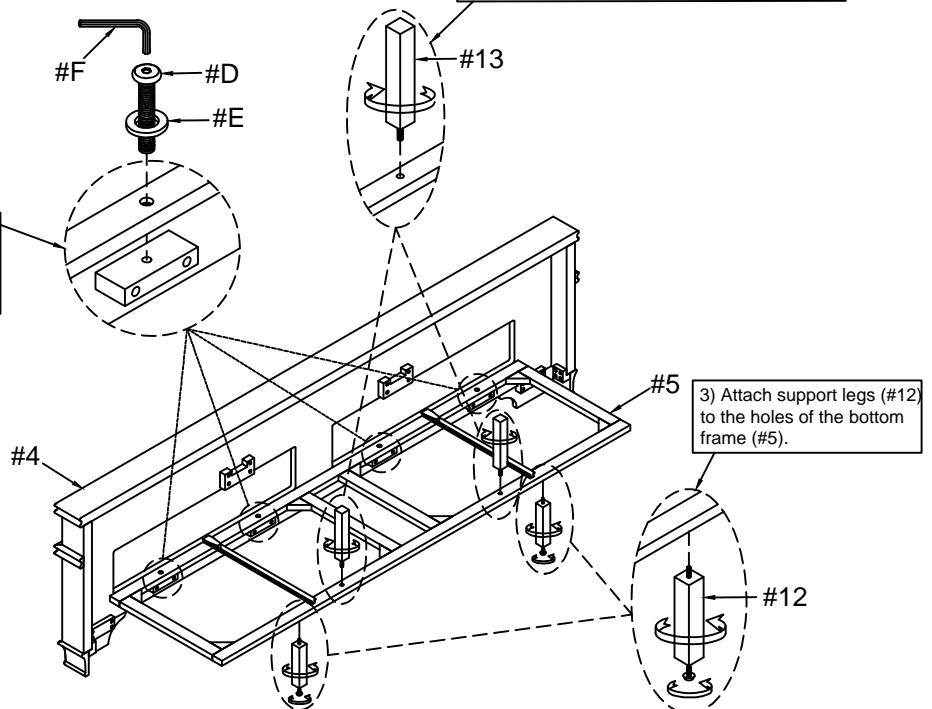

ASSEMBLY INSTRUCTIONS

3

- Part #6 x2pcs
- Hardware #J x8pcs
- Hardware #K x8pcs
- Hardware #L x8pcs

Attach threaded studs (#J) to the holes of the headboard (#1) and footboard (#4), then align side rails (#6R/L) to the threaded studs (#J). Secure by using washer (#K) with hex nut (#L).

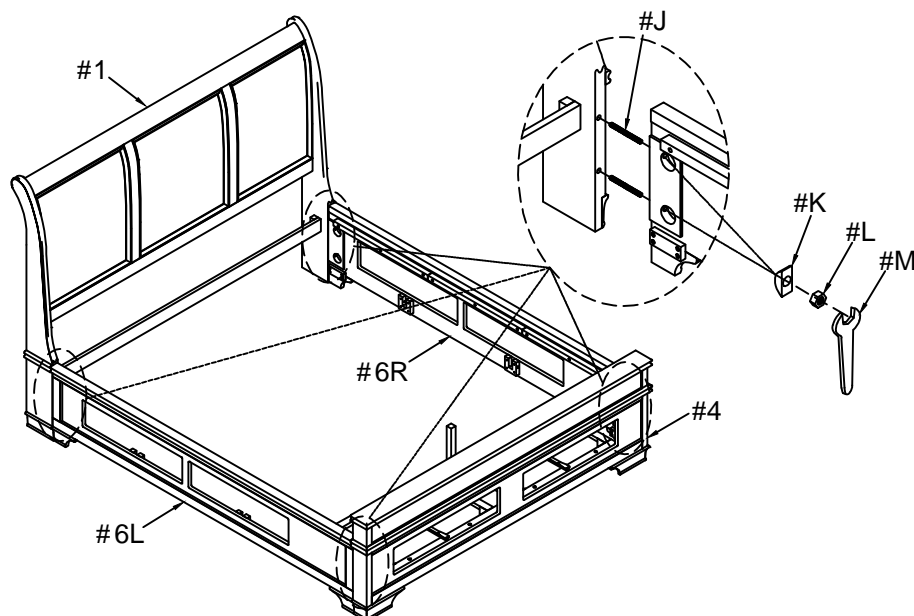

4

- Part #7 x2pcs
- Hardware #H x4pcs

Align rail drawer support slats (#7) to the side rails (#6R/L), then secure by using screws (#H).

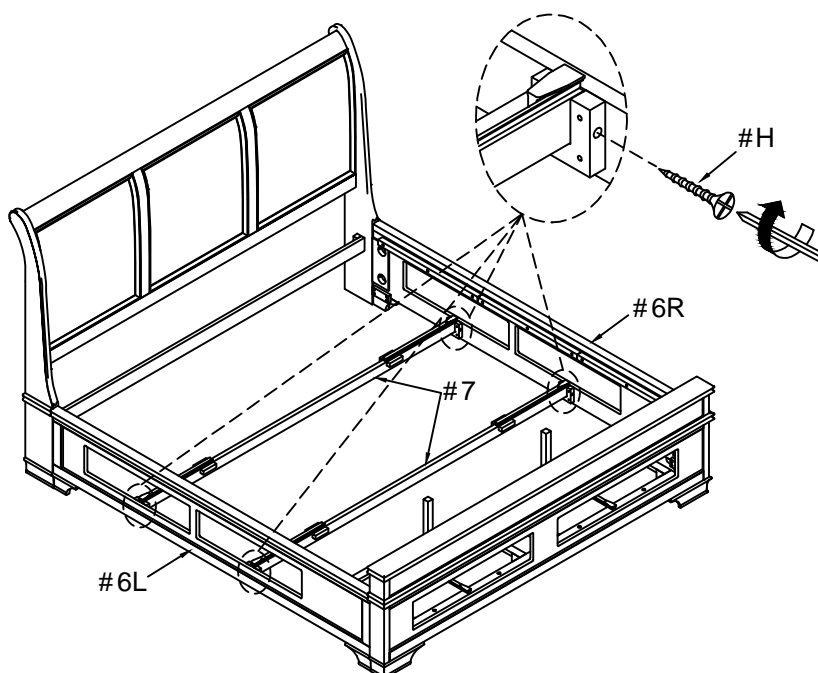

ASSEMBLY INSTRUCTIONS

5

- Part #8 x2pcs
- Part #11 x6pcs
- Part #14 x1pc

Align and attach support legs (#11) to the holes of the center slats (#8) and bed slats (#14). Adjust the leveler on the support legs (#11) according to ground level.

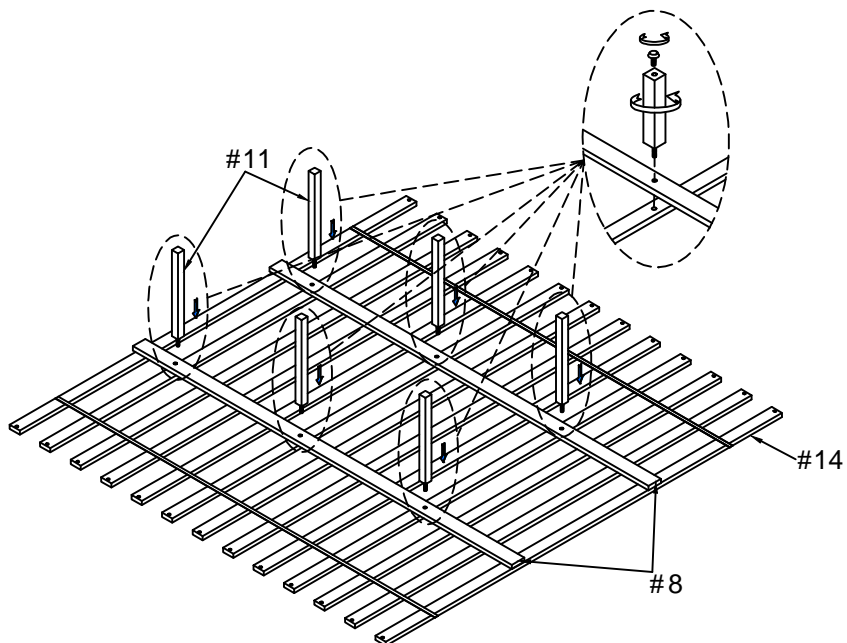

6

- Hardware #H x26pcs

Place bed slats (#14) to the side rails, then secure by using screws (#H).

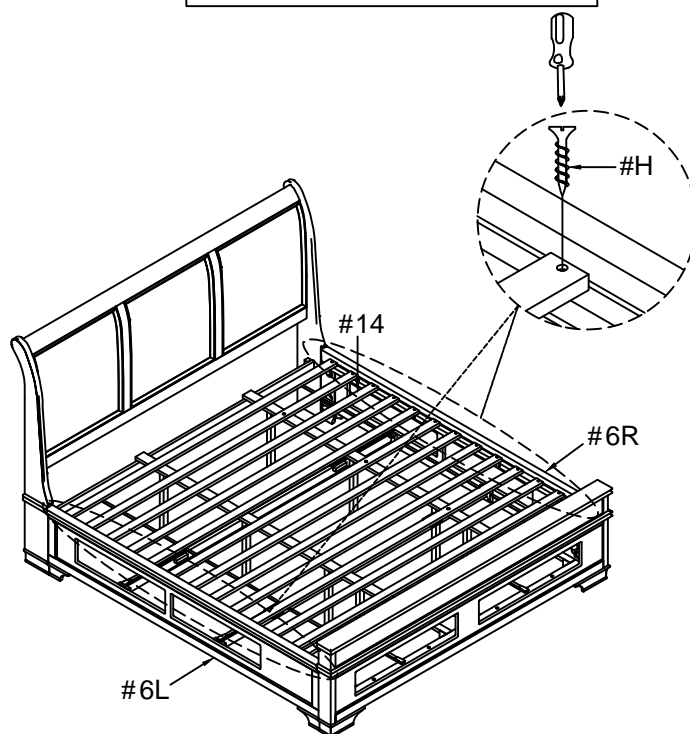

ASSEMBLY INSTRUCTIONS

7

Part #9 x4pcs

Part #10 x2pcs

Attach drawers (#9,10) to the drawer slat rails.

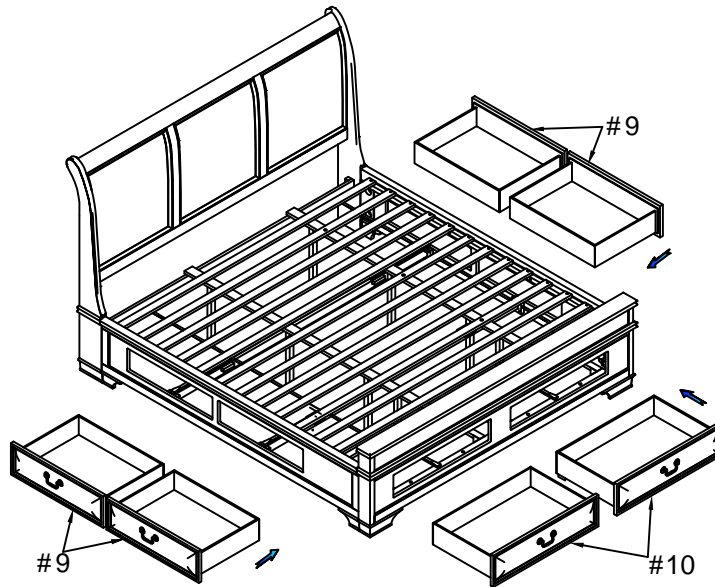

8

Part #15 x2pcs

Hardware #D x10pcs

Align top side rails (#15) to the upper holes of the side rails (#6). Secure by using bolts (#D).

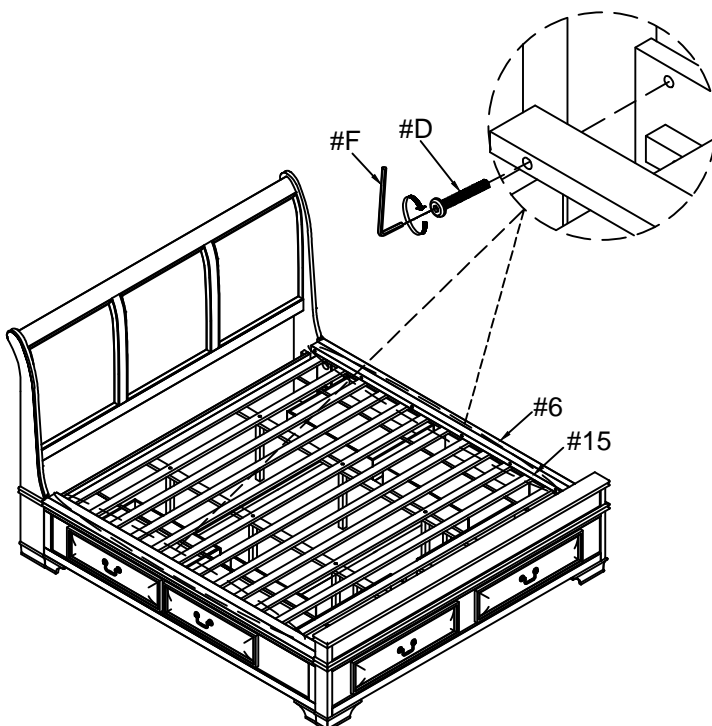

ASSEMBLY COMPLETED



Please ensure the furniture rests on an even and flat surface. If the product wobbles or feels loose, double-check all bolts and/or screws are properly tightened and secured.



Keep this handy!

Please retain this instruction manual and any order-related information for future reference.



Lift, don't drag!

To avoid damage to product please always LIFT the product when transporting or adjusting the placement.