

ASSEMBLY INSTRUCTIONS

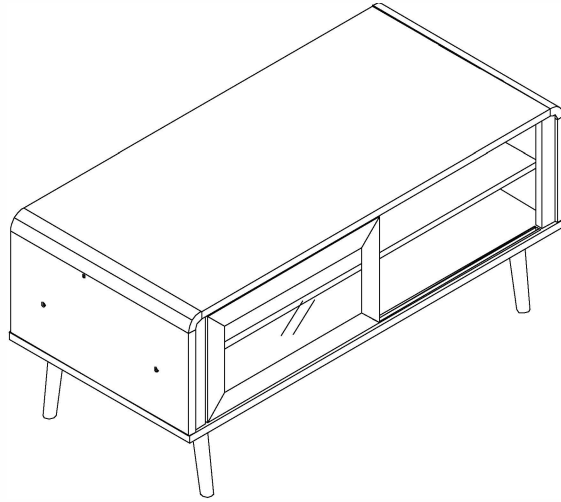









COFFEE TABLE

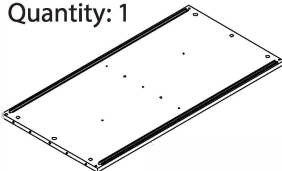
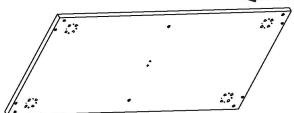
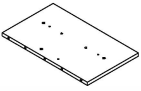



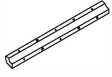

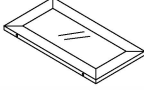

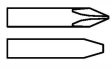

NOTE TO CUSTOMERS:

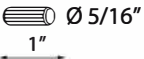
- For ease and speed of assembly we recommend that before you commence each step of the assembly that you identify all the parts required to complete that step.
- We recommend that where possible you allow sufficient space to assemble the item as close as possible to the place where it will be once assembled.
- For the protection of your furniture we recommend that the product is placed on a dry, soft, smooth and clean surfaces during assembly to prevent any damage. Avoid damp and direct sunlight.
- During assembly do not over tighten the screws or bolts, as this may damage the product.
- Please ensure you retain all the product packaging until the item is completely assembled.
- Periodically check all fitting and re-tighten as necessary.
- Never allow any liquids to remain on your furniture as absorption can cause the wood to warp or finish to de-laminate.
- It is recommended that this item should be assembled by two adults.

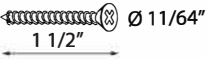
PARTS IDENTIFICATION

P1 Quantity: 1  Side Panel-Left	P2 Quantity: 1  Side Panel-Right	P3 Quantity: 1  Top Panel	P4 Quantity: 1  Bottom Panel	
P5 Quantity: 1  Center Panel	P6 Quantity: 2  Support Rail	P7 Quantity: 1  Left Shelf	P8 Quantity: 1  Right Shelf	P9 Quantity: 4  Stile
P10 Quantity: 2  Corner Connector	P11 Quantity: 1  Leg Support	P12 Quantity: 2  Sliding Door	Tools required: MALLET  HOUSEHOLD SCREWDRIVER 	

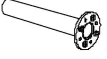
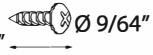
HARDWARE LIST

H1 Wooden Dowel M8 x 25  Quantity: 32 pcs	H2 Connecting Bolts  Quantity: 19 pcs	H3 Screw #9 X 1 1/2"  Quantity: 20 pcs	H4 Cam Lock 15 x 12.5mm  Quantity: 19 pcs	H5 Screw m5.1 x 38 for leg support  Quantity: 2 pcs
H6 Plastic Nail Leg Stud  Quantity: 1 pc	H7 Plastic Leg  Quantity: 4 pcs	H8 Screw for Legs M3.5 x 16 pan head  Quantity: 16 pcs	H9 Door Slider Pin  Quantity: 8 pcs	H10 Colored Sticker  Quantity: 8 pcs

STEP 1 Insert wooden dowels (H1) into the following parts,

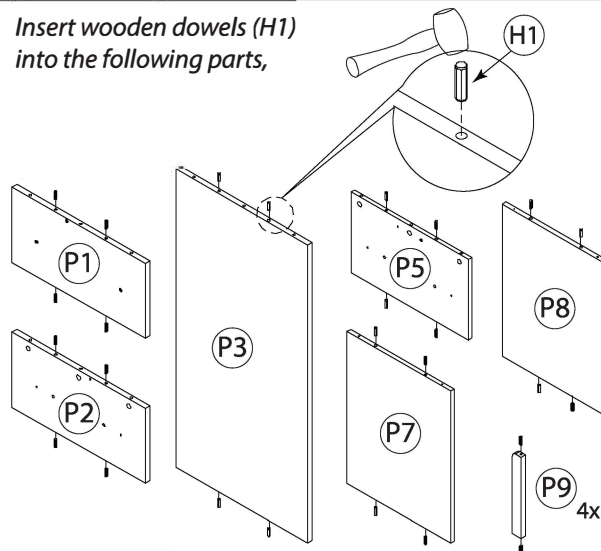

STEP 2 Align the Connecting Bolt (H2), use a household Philip Screwdriver to drive the bolt until it is snug.

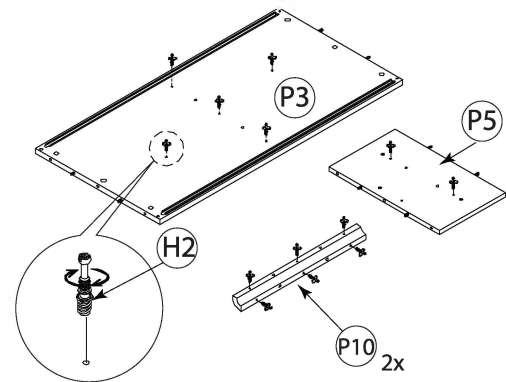

STEP 3

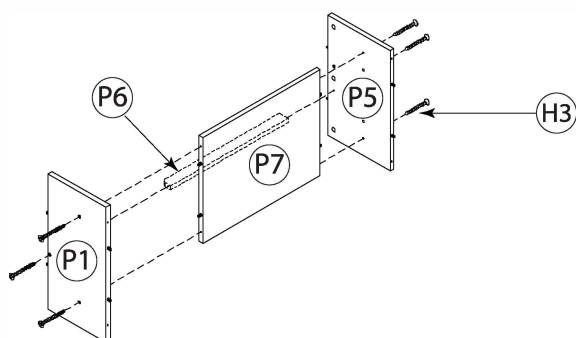

STEP 4

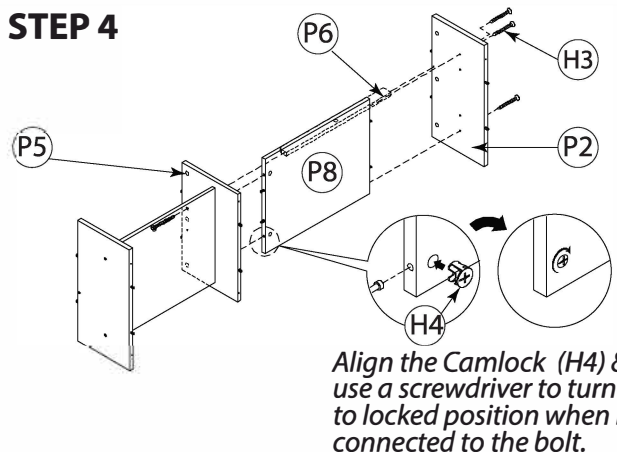

STEP 5

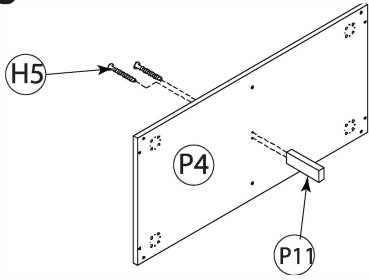

STEP 6

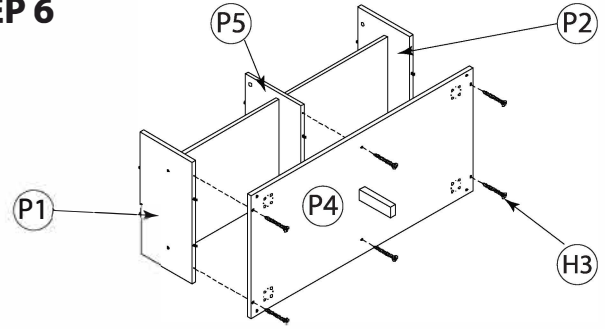

STEP 7

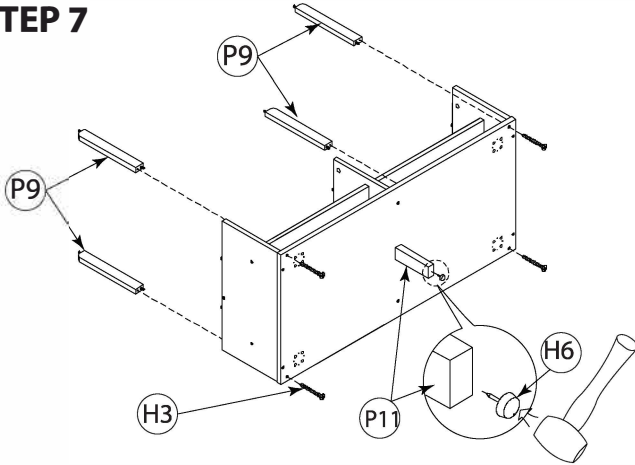

STEP 8

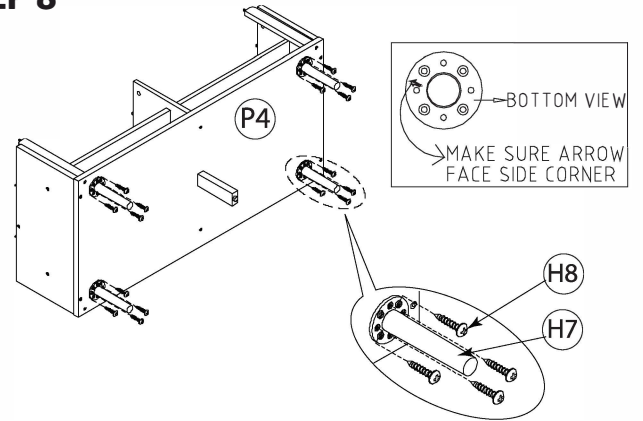

STEP 9

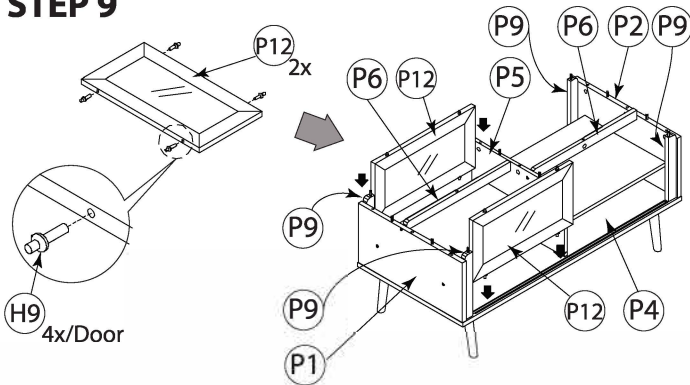

STEP 10

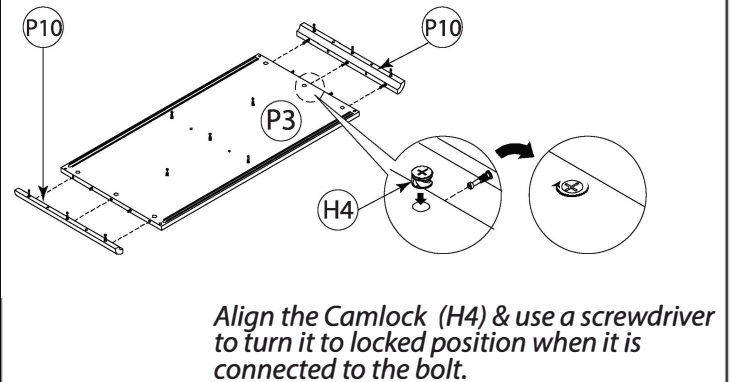

STEP 11

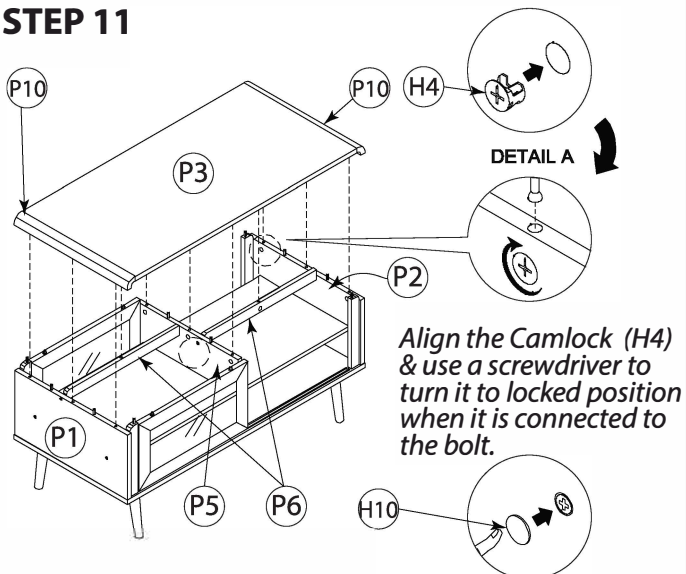

Paste the provided sticker to cover the screw hole.

STEP 12

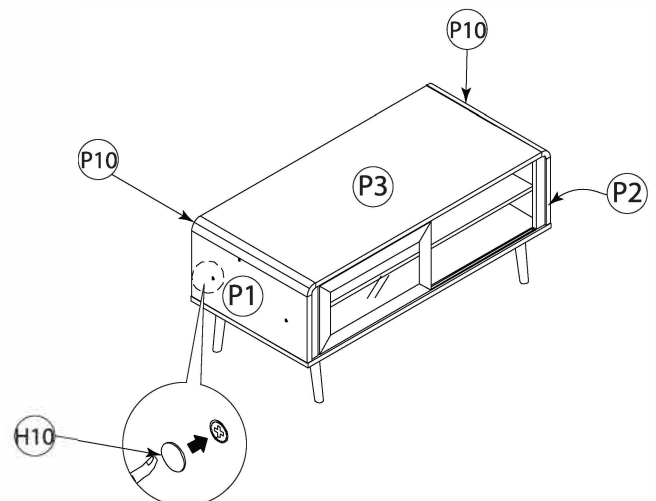

Paste the provided sticker to cover the screw hole.