

INSTRUCTION MANUAL ENCLOSED

ATTENTION

**IF YOU HAVE ANY PROBLEMS OR QUESTIONS, EMAIL OR CALL
CUSTOMER SERVICE BEFORE YOU RETURN THIS PRODUCT TO THE
STORE WHERE IT WAS PURCHASED.**

****When emailing Customer Service, please include your **Order Number** and **platform of purchase** in the email subject for quicker assistance.**

INSTRUCTION MANUAL ENCLOSED





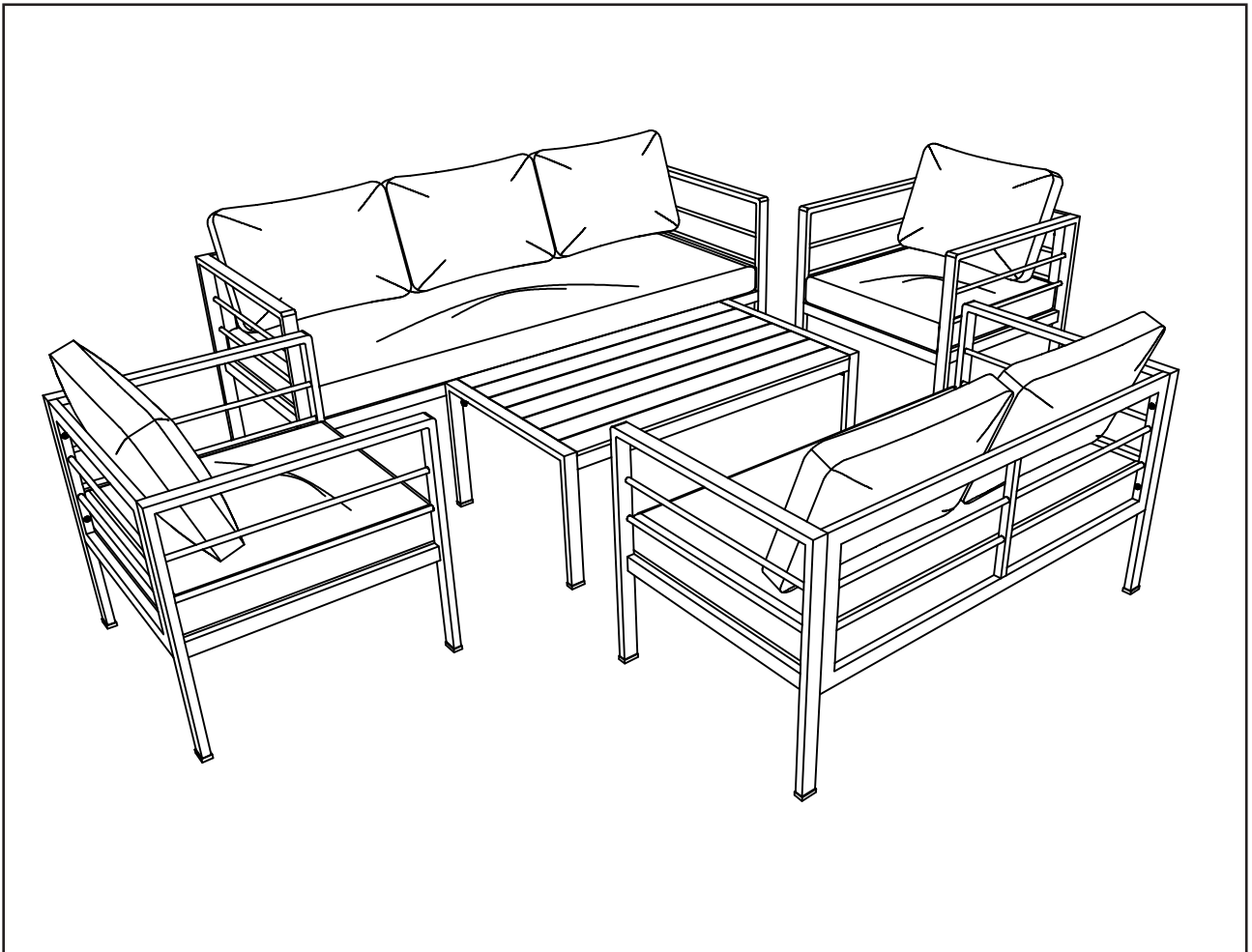







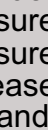



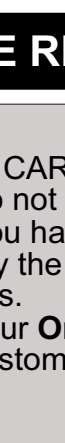

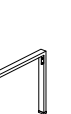
5PCS OUTDOOR METAL SOFA SET

5PCS OUTDOOR METAL SOFA SET ASSEMBLY INSTRUCTION

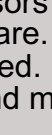

PARTS LIST

Part	Description	Quantity
PARTS		
1	Right arm	4
2	Left arm	4
3	Chair seat base	2
4	Chair backrest	2
5	Bench 2 seat base	1
6	Bench 2 backrest	1
7	Bench 3 seat base	1
8	Bench 3 backrest	1
9	Bench 3 middle leg	1
10	Table leg	2
11	Polywood table top	1
12	Pillow	7
13	Chair cushion	2
14	Bench 2 cushion	1
15	Bench 3 cushion	1
HARDWARE		
A	Bolt M6x20 mm	10
B	Bolt M6x40 mm	27
C	Bolt M6x55 mm	16
D	Washer Ø6x14x1 mm	53
E	Allen key 4x98 mm	2

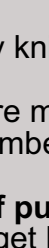
1  x4	2  x4	3  x2	4  x2
5  x1	6  x1	7  x1	8  x1
9  x1	10  x2	11  x1	12  x7
13  x2	14  x1	15  x1	A  M6x20 mm x10
B  M6x40 mm x27	C  M6x55 mm x16	D  Ø14x1 mm x53	E  4 mm x2

PLEASE READ AND FOLLOW ALL SAFETY TIPS

GETTING STARTED

1. Before assembly, CAREFULLY use scissors or utility knife to cut and unwrap all parts. Make sure you do not discard the hardware.
2. Make sure that you have all the parts listed. If you are missing any parts, please email us. Please identify the parts you need and model number. Make sure to include your name and address.
3. Please include your **Order Number** and **platform of purchase** in the email subject, and one of our customer service representative will get back to you.

Warm Tips:

1. The plastic covers on some metal parts are just for product protection. Please remove it before assembly.
2. Please follow the sequence of AI during assembly.
3. Do not tighten the screws until all of them are in right positions.

1. Locate the chair seat base (3) to the chair backrest (4) by the pre-drilled threads. Use Allen Key (E) to tighten Bolts (B) and Washers (D).
Note: only tighten 80% (Photo 1).

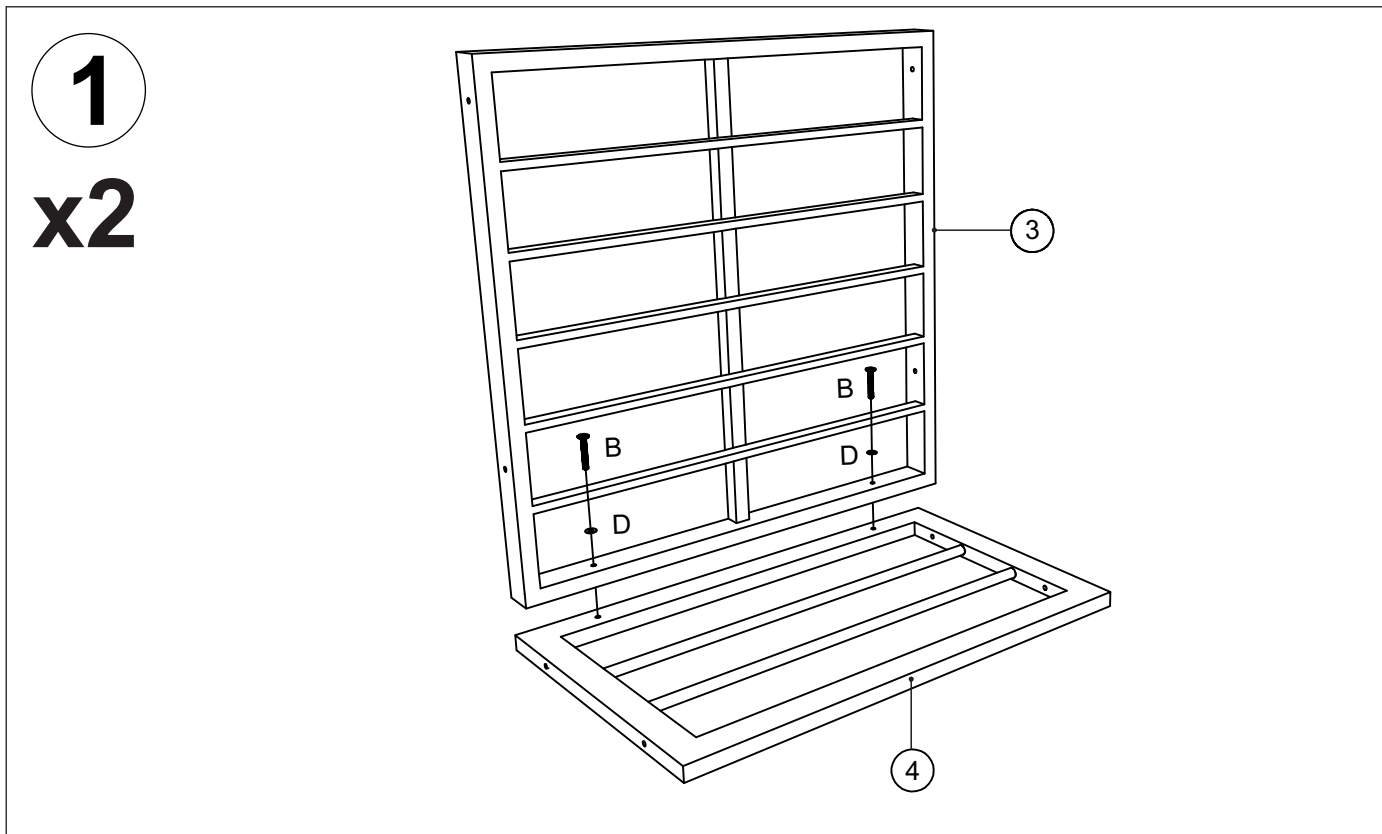

2. Locate the assembly installed in step (1) to the right arm (1) by the pre-drilled threads. Use Allen Key (E) to tighten Bolts (B), Bolts (C) and Washers (D).
Note: only tighten 80% (Photo 2).

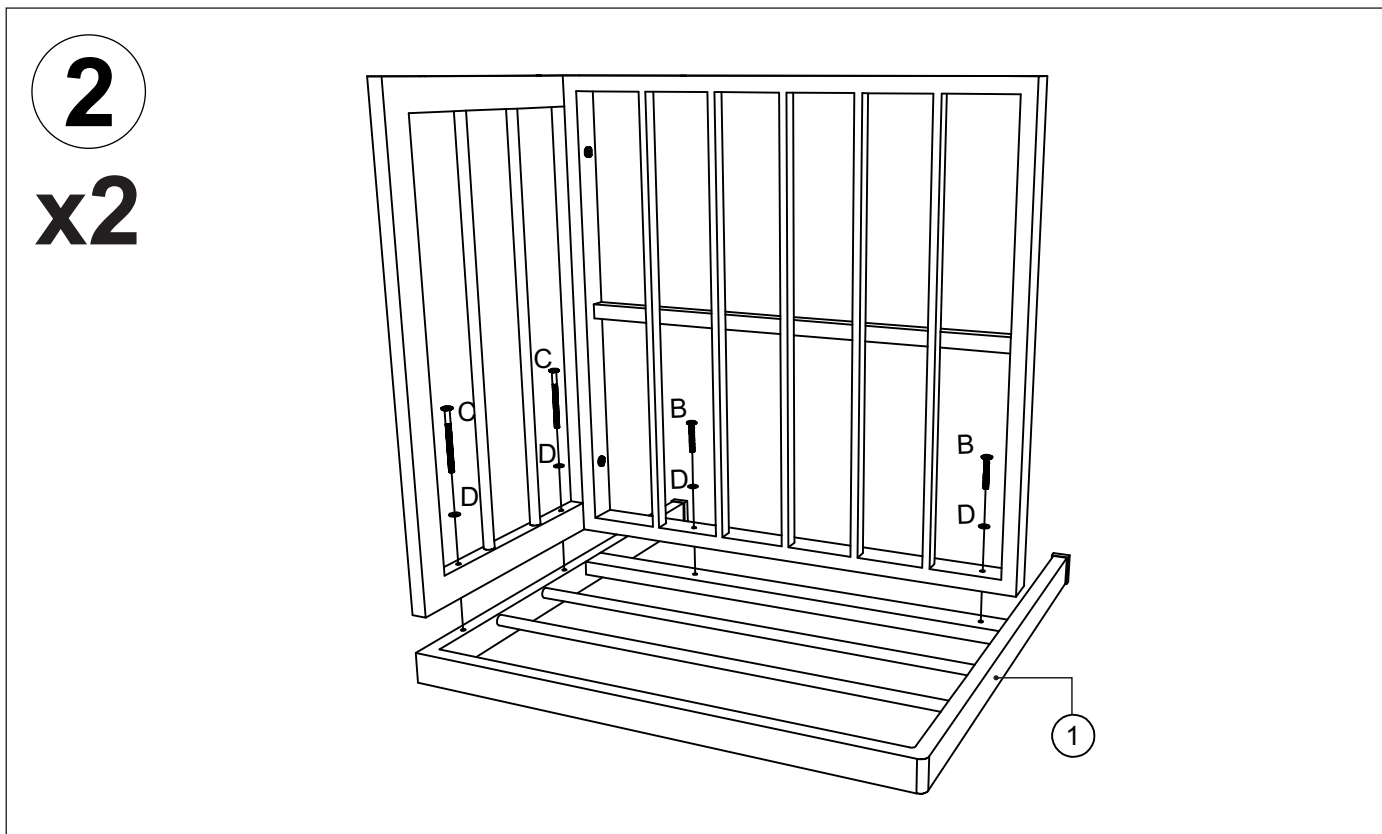

3. Locate the assembly installed in step (2) to the left arm (2) by the pre-drilled threads.
Use Allen Key (E) to tighten Bolts (B), Bolts (C) and Washers (D).
Note: only tighten 80% (Photo 3).

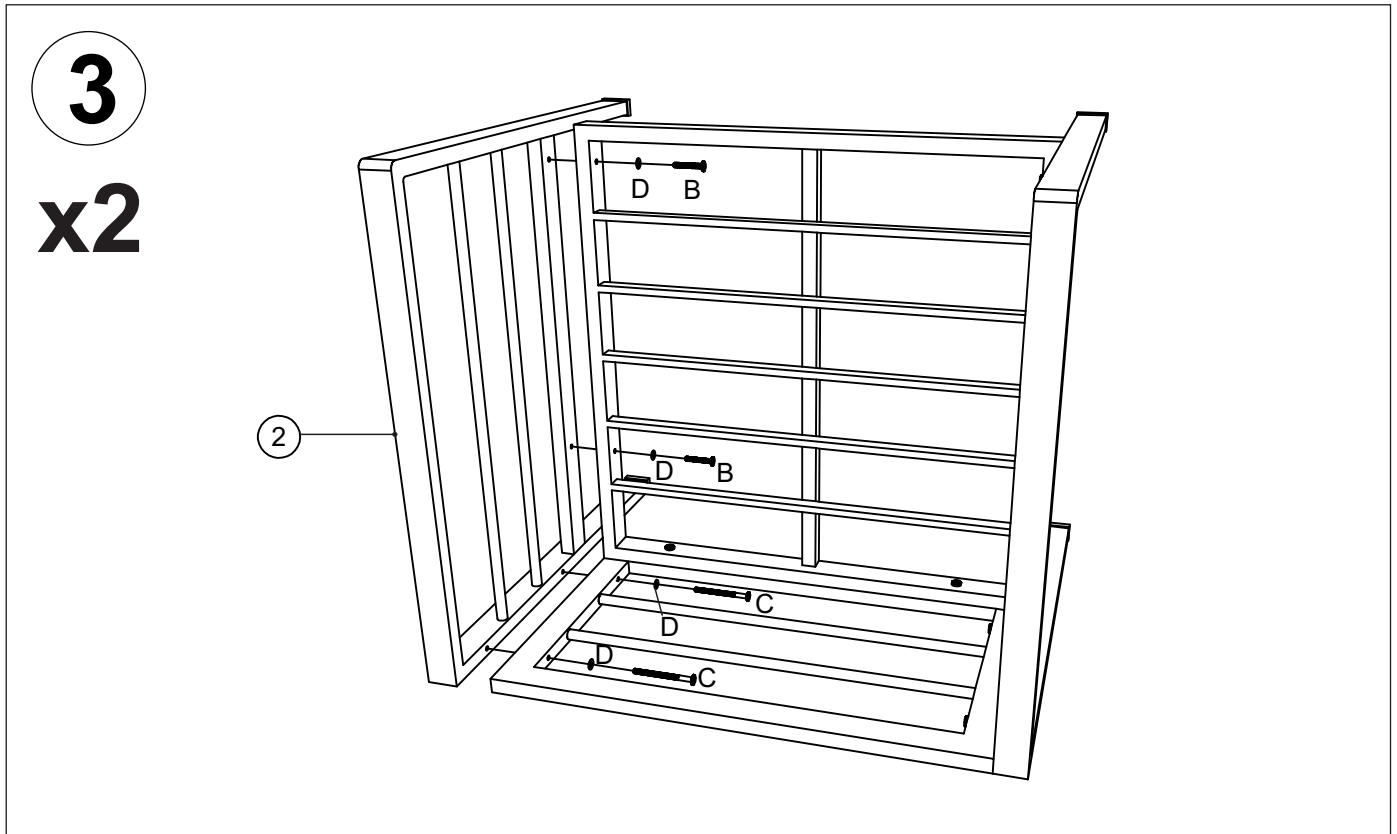

4. Use Allen Key (E) to tighten all Bolts 100%.
Place 1 chair cushion (13) on the top seat first, and then place 1 pillow (12) above it (Photo 4).

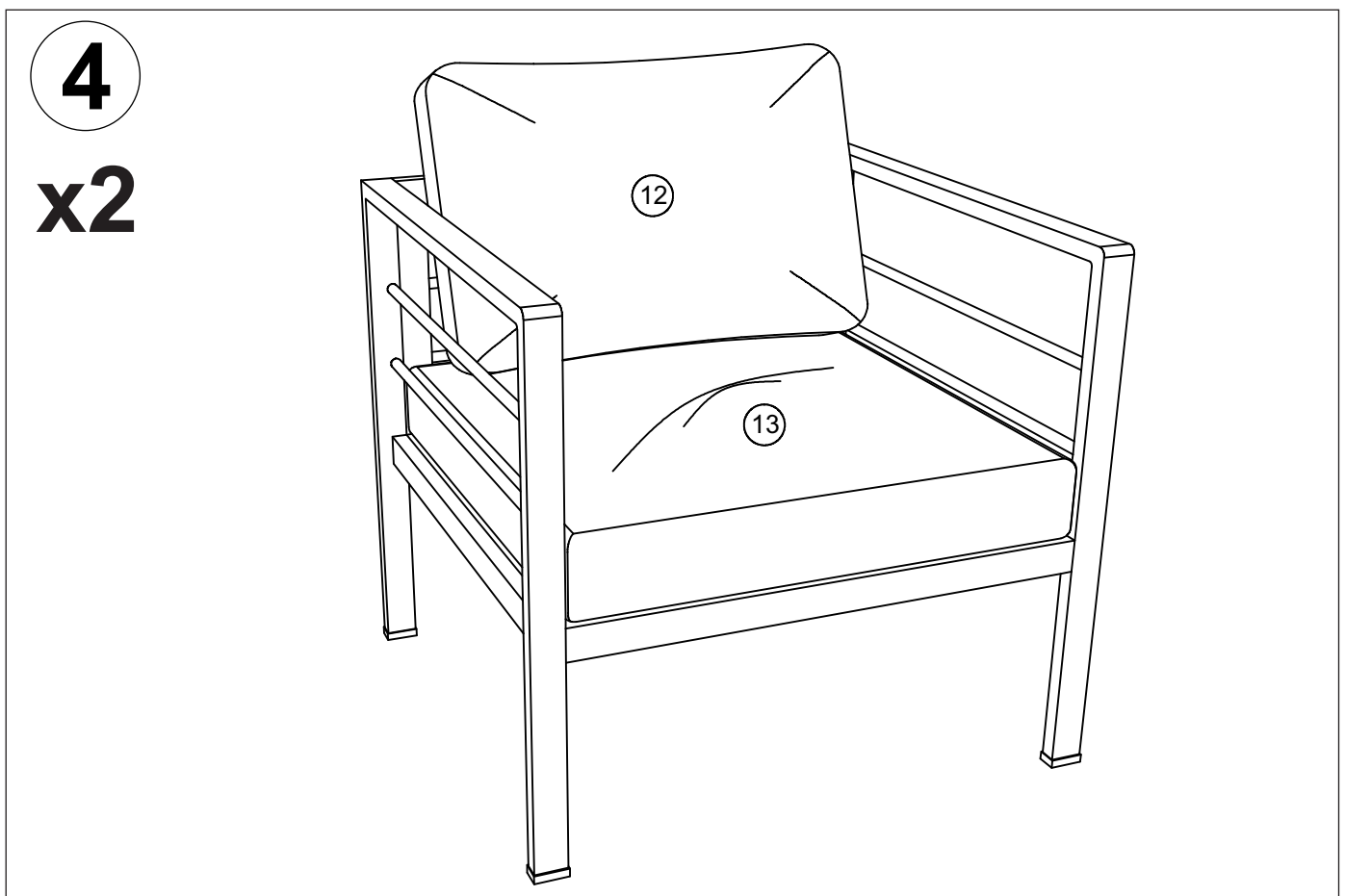

5. Locate the bench 2 seat base (5) to the bench 2 backrest (6) by the pre-drilled threads.
Use Allen Key (E) to tighten Bolts (B) and Washers (D).
Note: only tighten 80% (Photo 5).

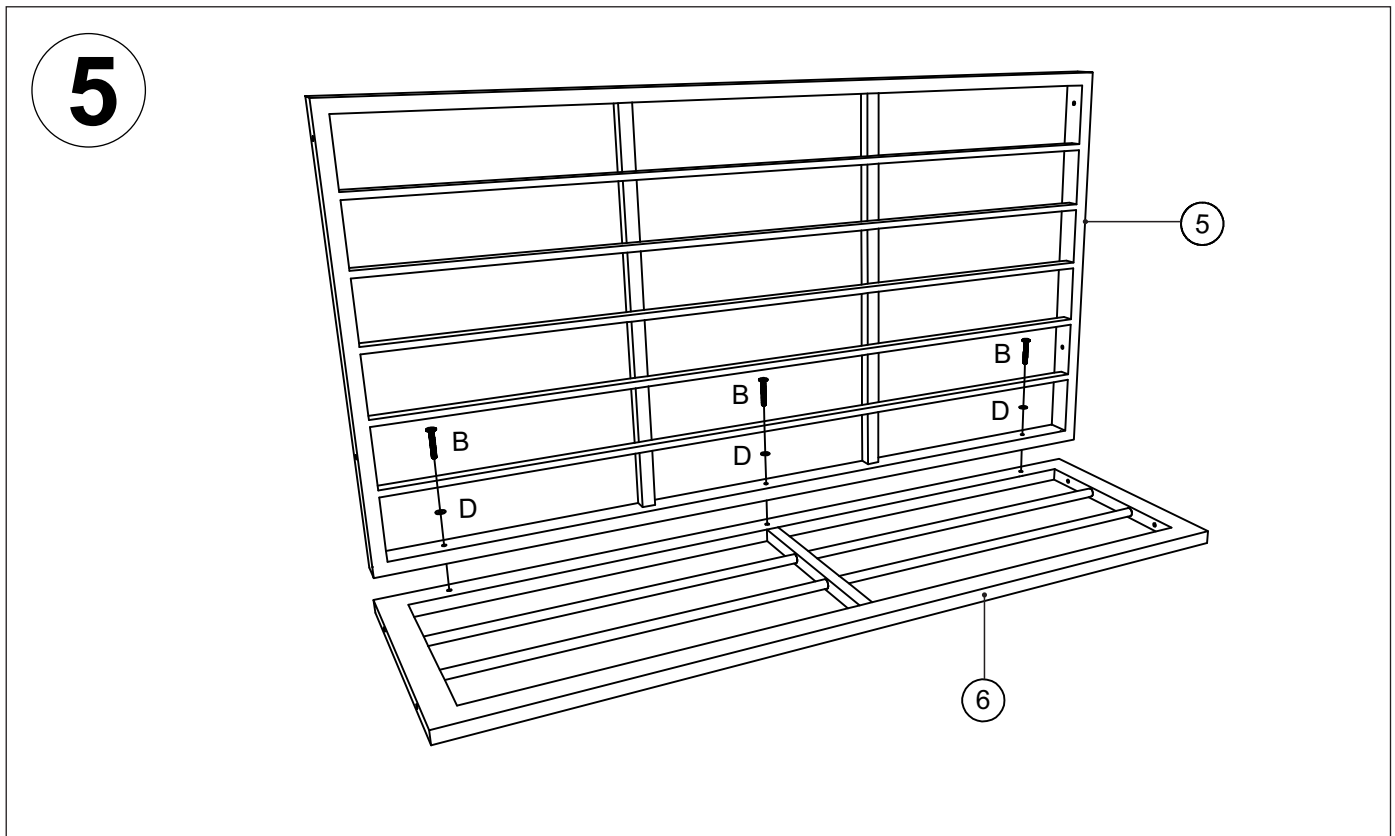

6. Locate the assembly installed in step (5) to the right arm (1) by the pre-drilled threads.
Use Allen Key (E) to tighten Bolts (B), Bolts (C) and Washers (D).
Note: only tighten 80% (Photo 6).

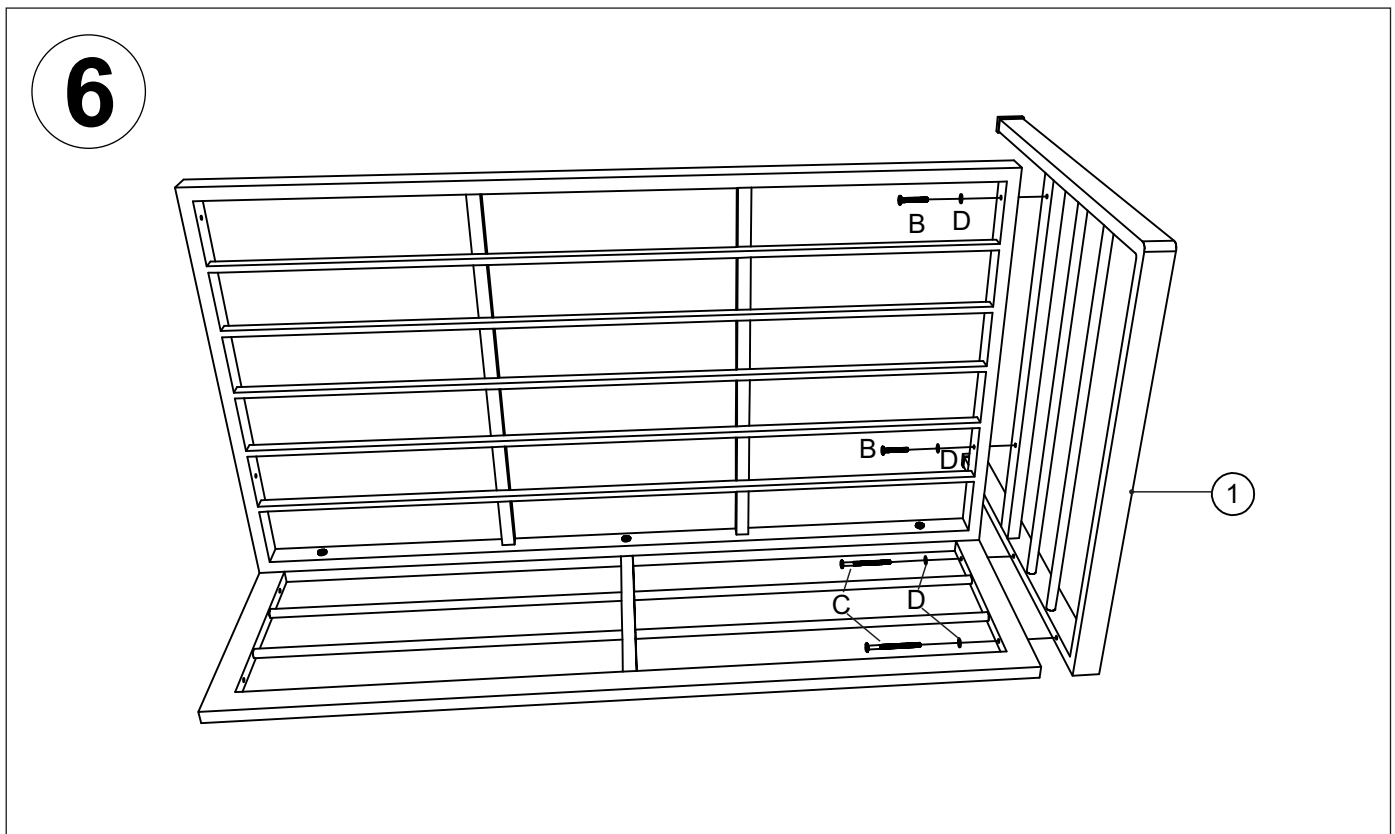

7. Locate the assembly installed in step (6) to the left arm (2) by the pre-drilled threads.
Use Allen Key (E) to tighten Bolts (B), Bolts (C) and Washers (D).
Note: only tighten 80% (Photo 7).

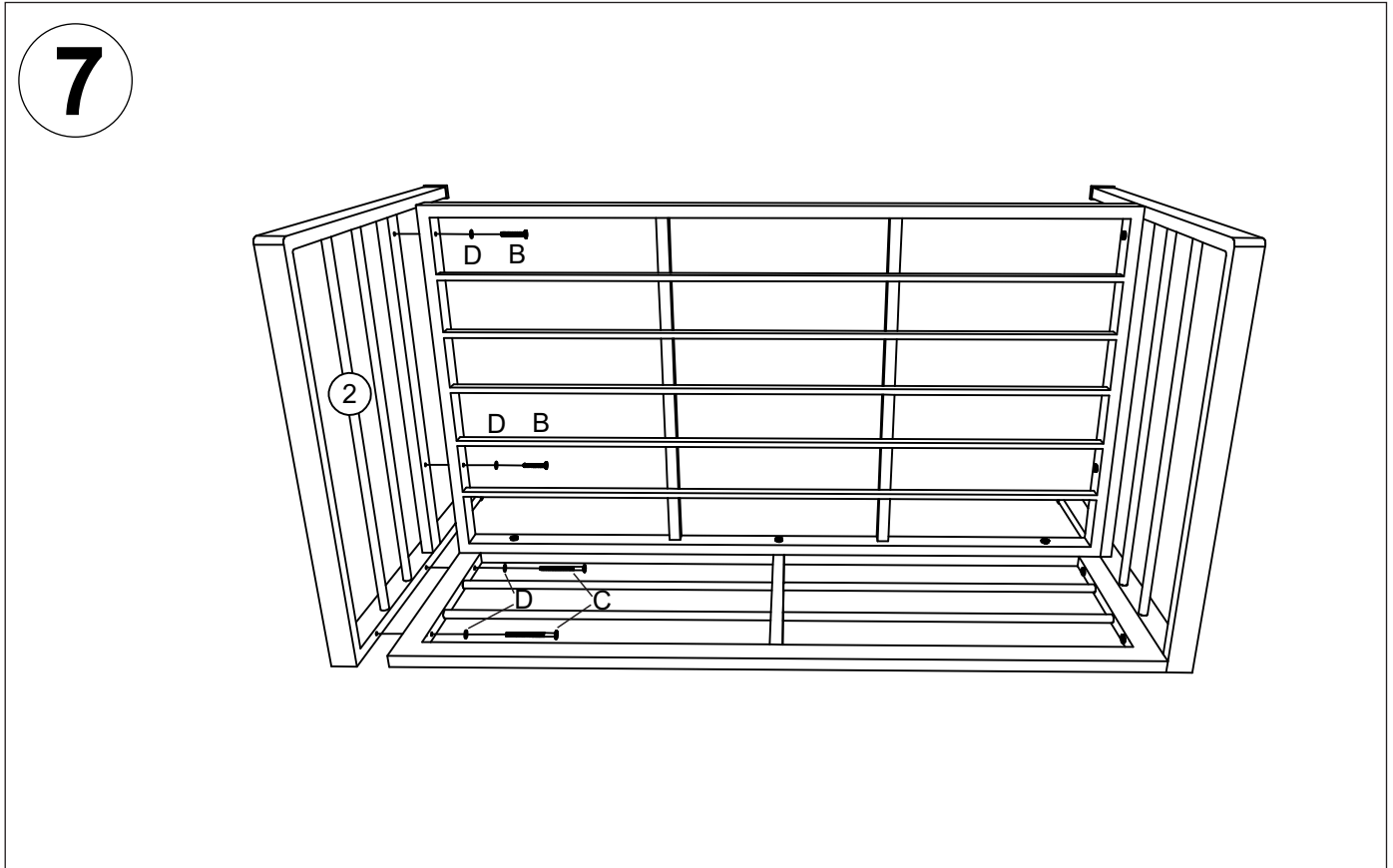

8. Use Allen Key (E) to tighten all Bolts 100%.
Place 1 bench 2 cushion (14) on the top seat first, and then place 2 pillows (12) above it (Photo 8).

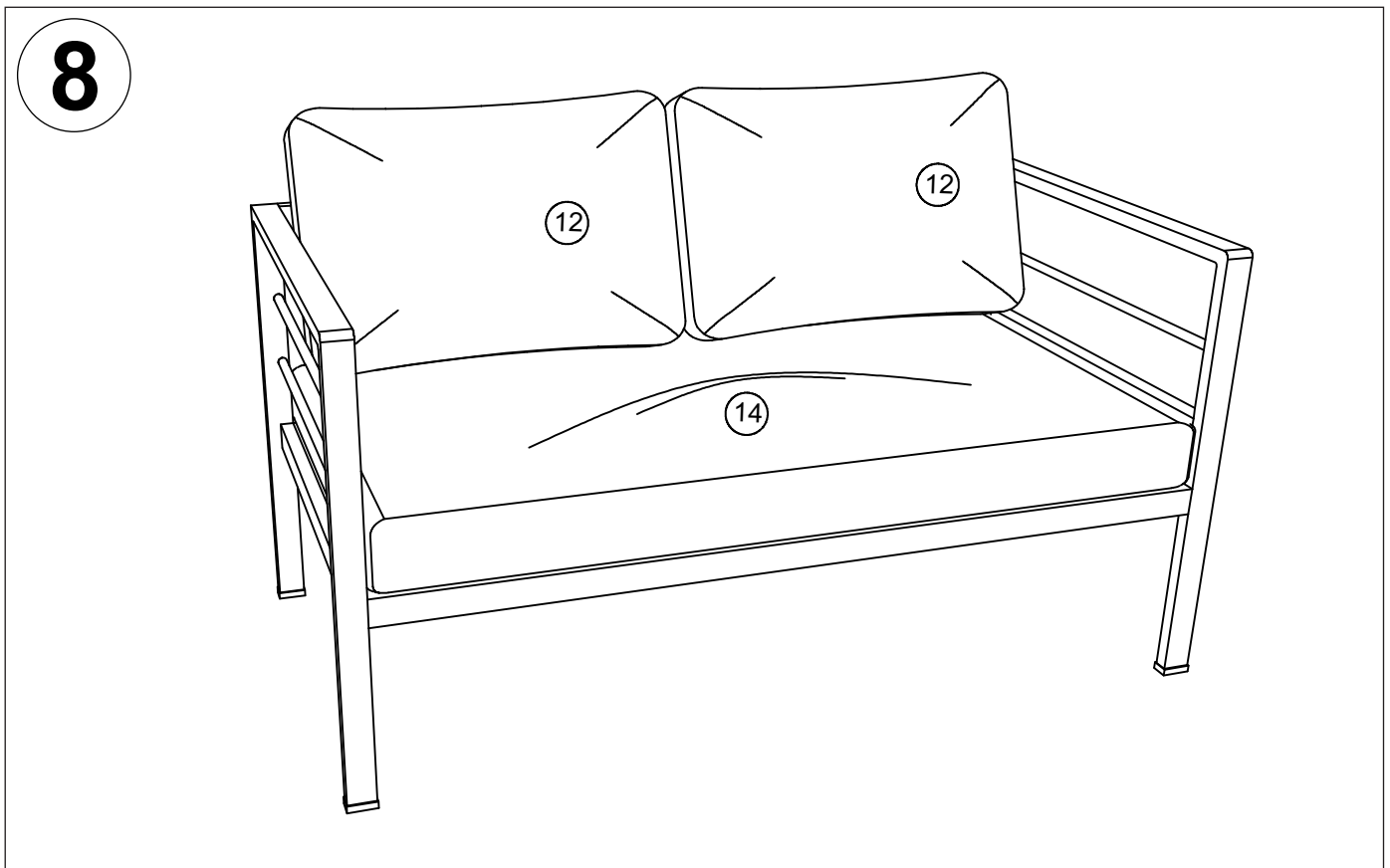

9. Locate the bench 3 seat base (7) to the bench 3 backrest (8) by the pre-drilled threads. Use Allen Key (E) to tighten Bolts (B) and Washers (D).
Note: only tighten 80% (Photo 9).

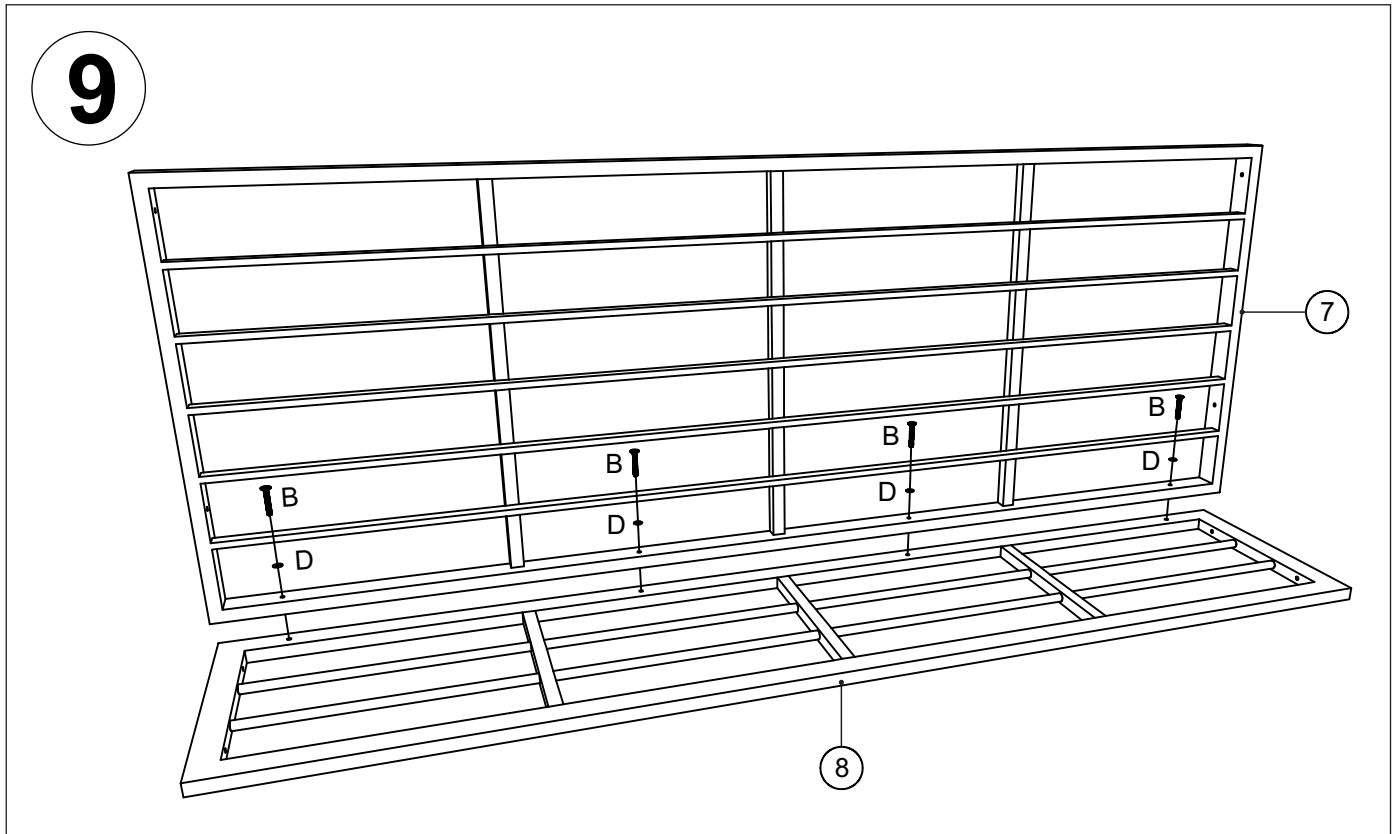

10. Locate the assembly installed in step (9) to the right arm (1) by the pre-drilled threads. Use Allen Key (E) to tighten Bolts (B), Bolts (C) and Washers (D).
Note: only tighten 80% (Photo 10).

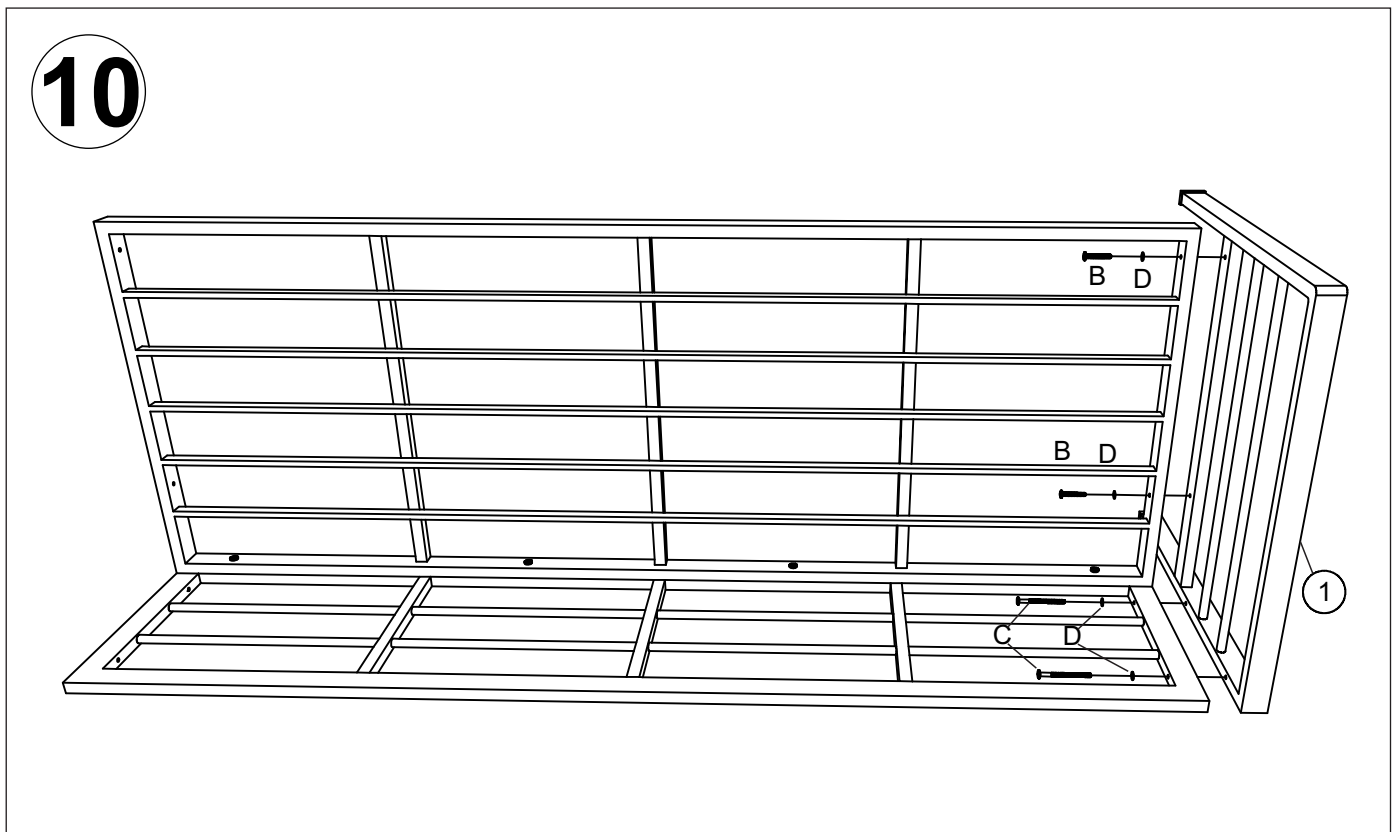

11. Locate the assembly installed in step (10) to the left arm (2) by the pre-drilled threads. Use Allen Key (E) to tighten Bolts (B), Bolts (C) and Washers (D). Note: only tighten 80% (Photo 11).

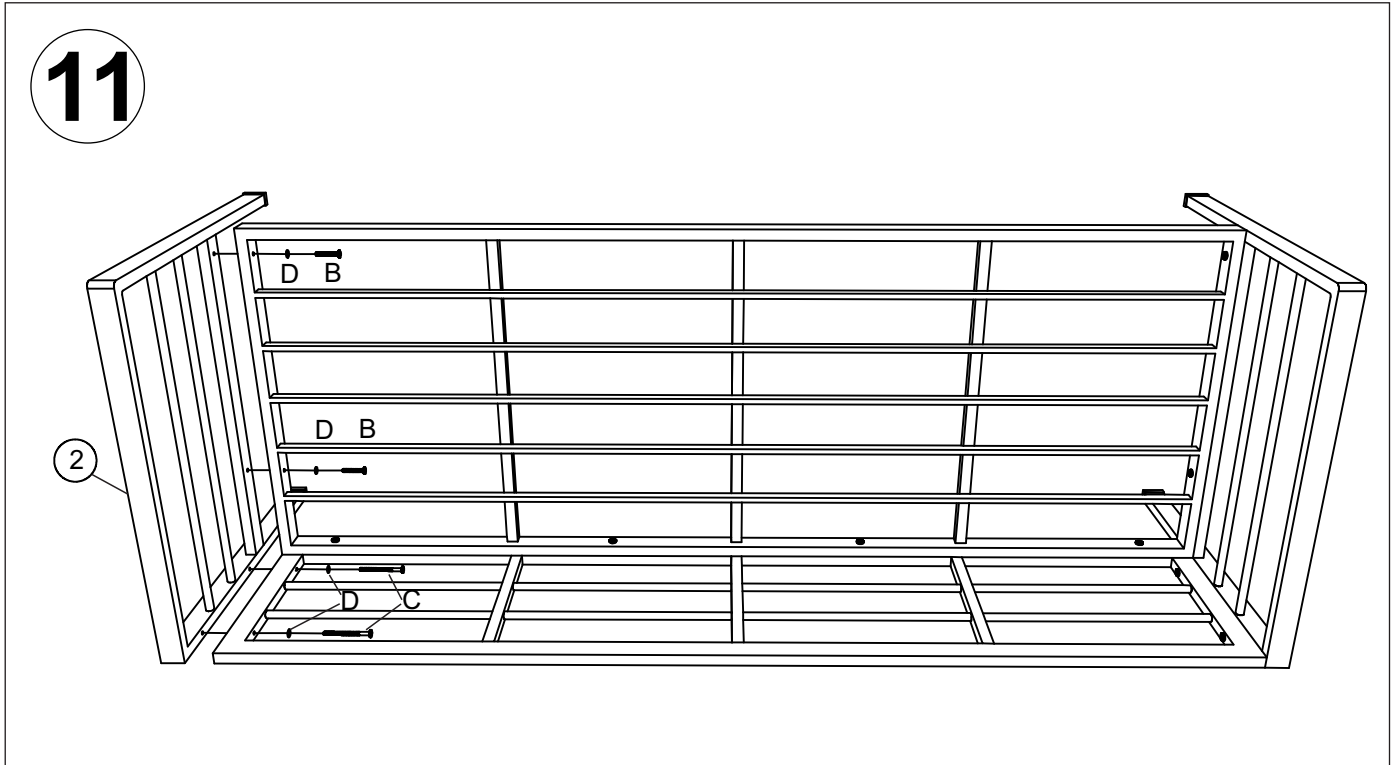

12. Locate Bench 3 middle leg (9) to the bench 3 seat base (7) by the pre-drilled threads. Use Allen Key (E) to tighten Bolts (A) and Washers (D). Fixed all bolts 100% (Photo 12).

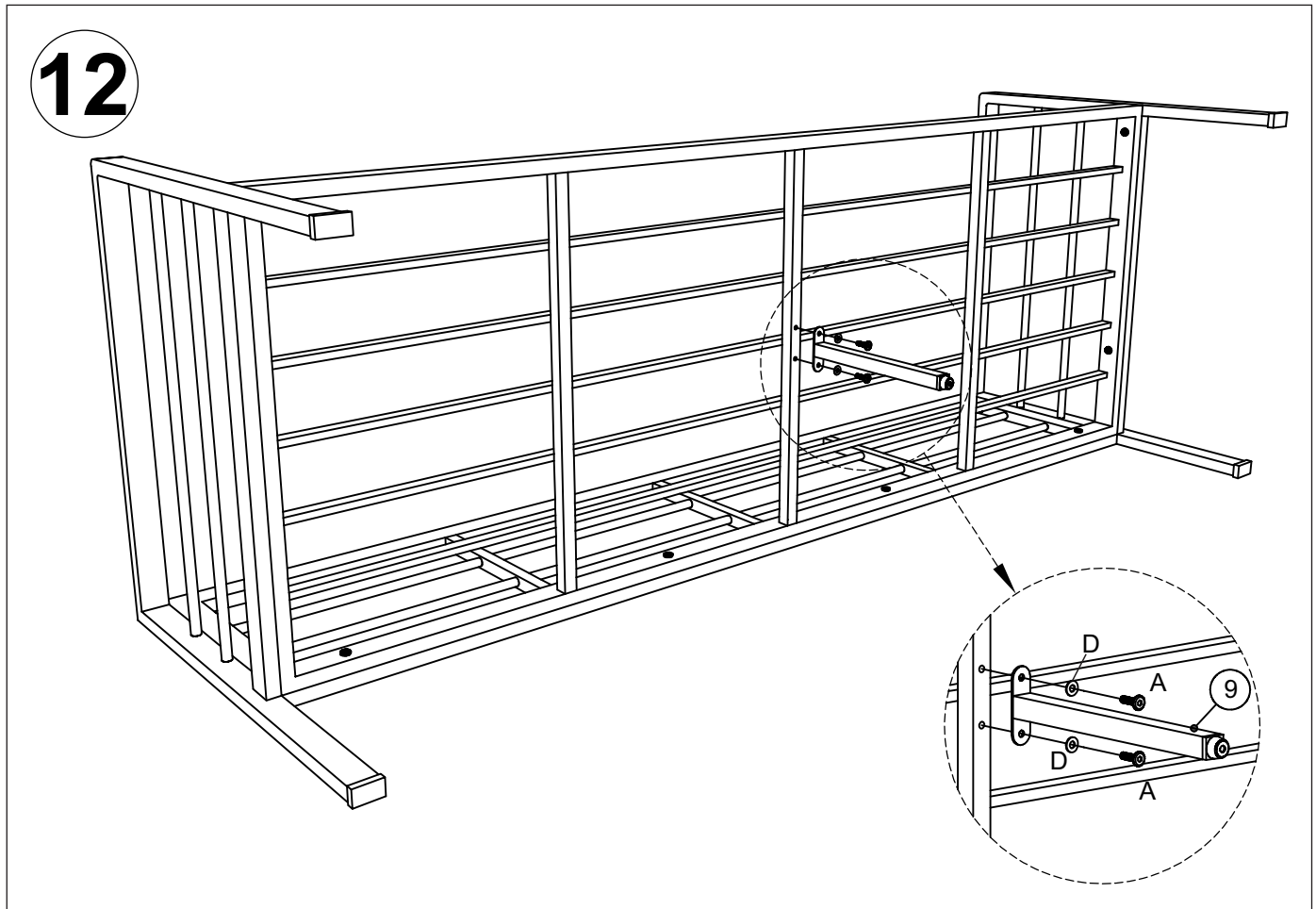

13. Use Allen Key (E) to tighten all Bolts 100%.

Place 1 bench 3 cushion (15) on the top seat first, and then place 3 pillows (12) above it (Photo 13).

13

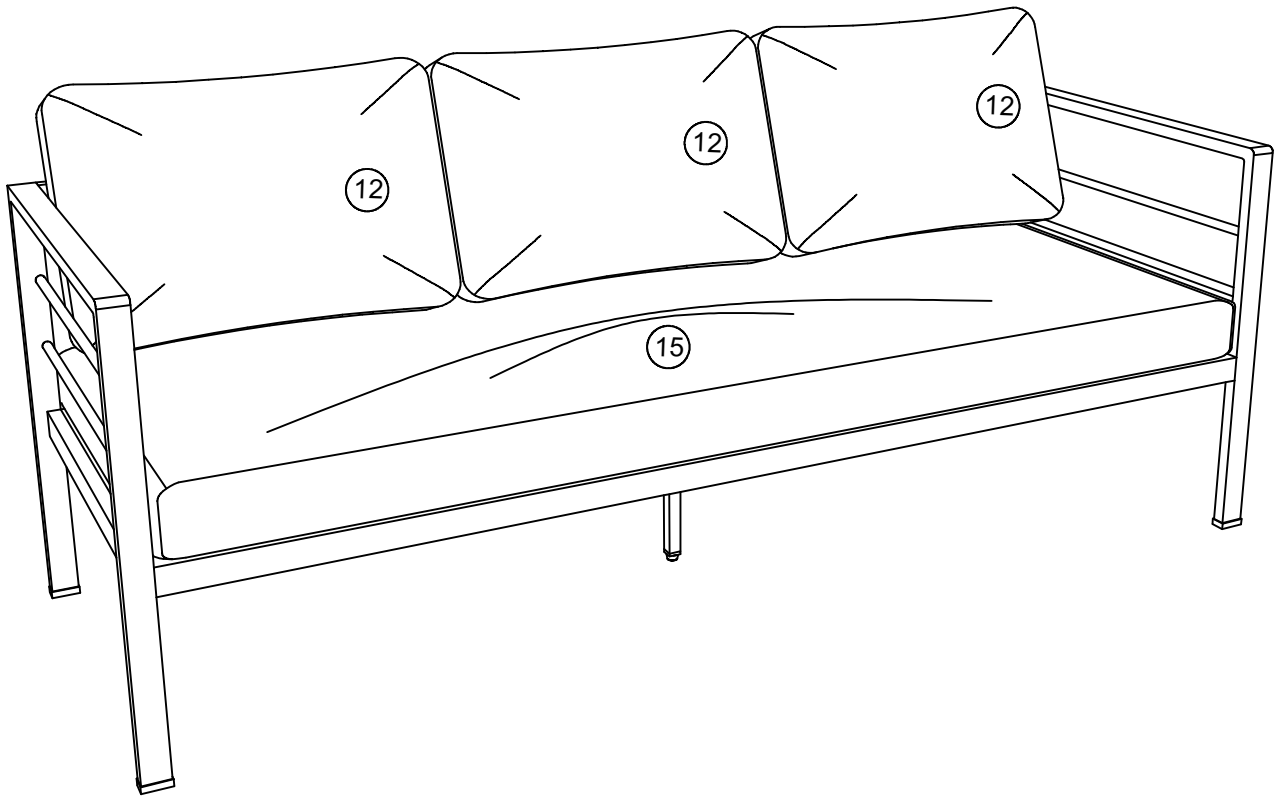

14. Locate 2 table legs (10) to the polywood table top (11) by the pre-drilled threads.
Use Allen Key (E) to tighten Bolts (A) and Washers (D).
Fixed all bolts 100% (Photo 14).

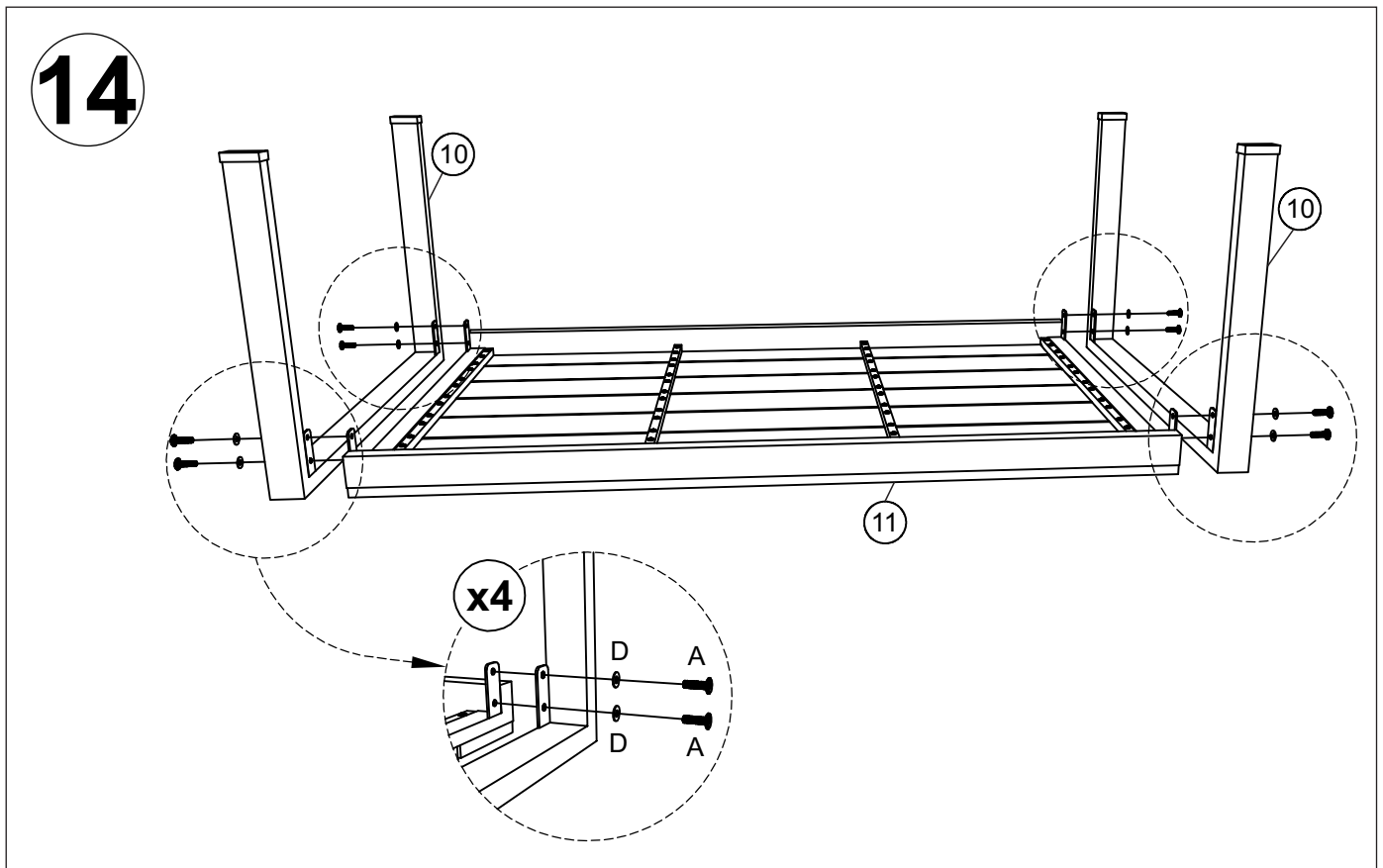

15. Finished table assembly (Photo 15).

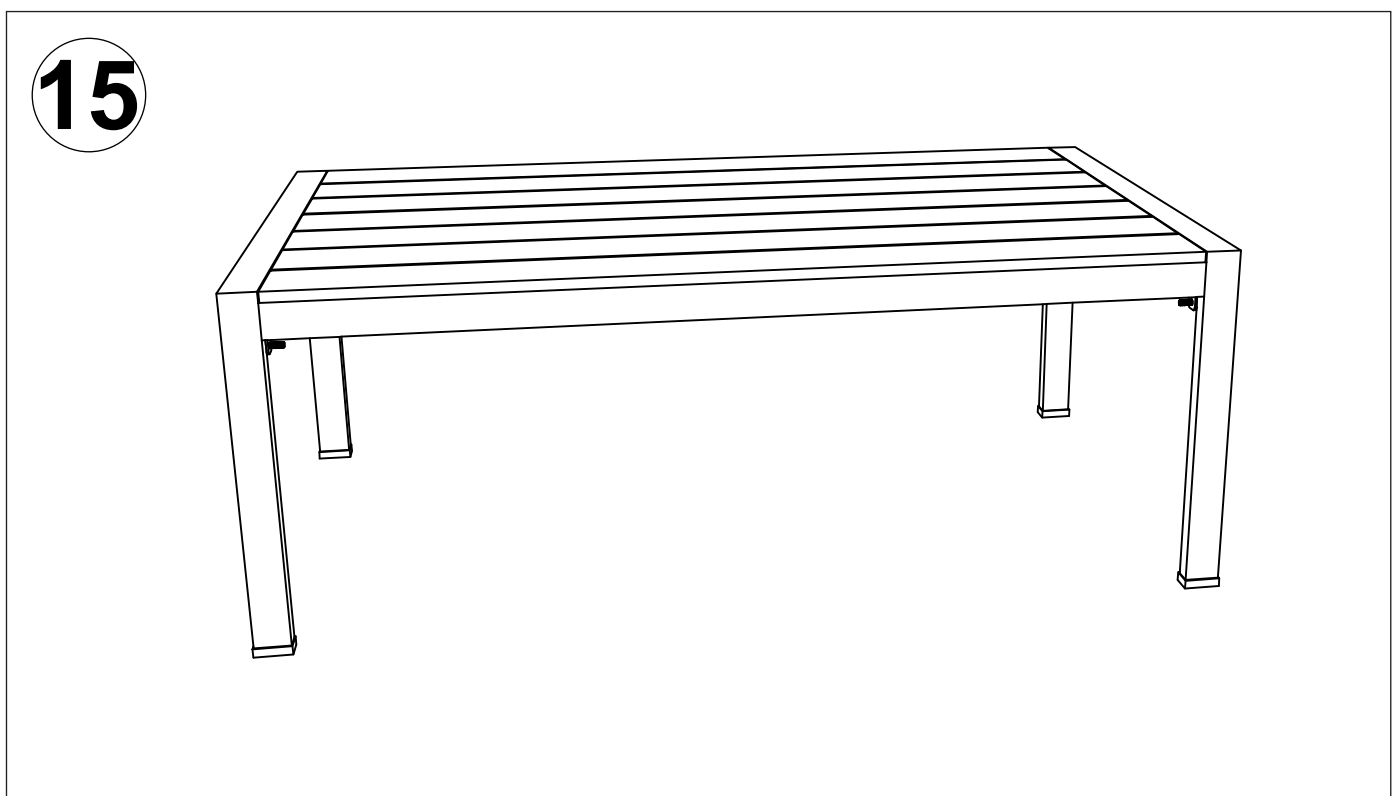

Till now you have finished the whole assembly and enjoy your furniture!