



Assembly Instructions

CAUTION: You must read these Assembly Instructions before you proceed.





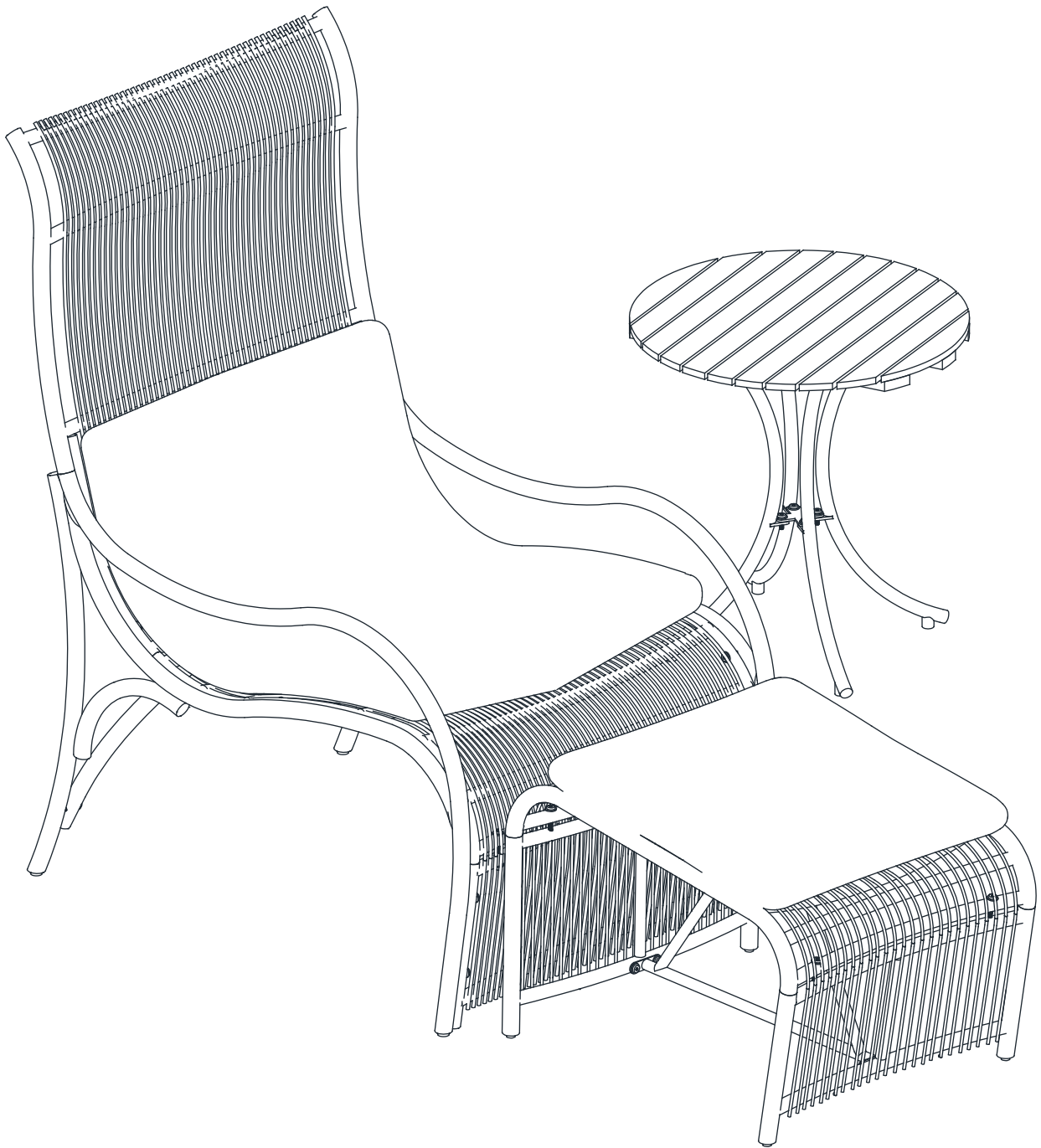

Care & Maintenance

- ⊘  ● Not for commercial use. For residential use only.
 - ✓  ● Furniture may scratch floors. We recommend using furniture pads to protect your floors.
 - ⊘  ● Do not put hot items directly on furniture surface.
 - ⊘  ● Do not clean furniture with harsh cleansers or polish.
 - ⊘  ● Do not place furniture under direct sunlight
 - ⊘  ● Do not place furniture near heating or cooling vents.
 - ⊘  ● Do not write on furniture without a padded barrier to protect the surface.
 - ⊘  ● Do not place furniture outside. For indoor use only.
 - ⊘  ● Stains may be removed with mild soap solution and damp cloth.
 - ⊘  ● Children should not climb or jump on the furniture.
-
- ✓  ● Dust and pick-up spills using a clean, non-colored, lint-free cloth.

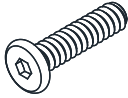
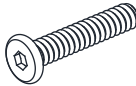
OVERVIEW

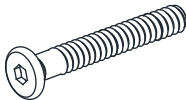

Hardware List

Label	Picture	Description	QTY
①		Bolt (M6 x 15mm)	18
②		Bolt (M6 x 25mm)	1
③		Bolt (M6 x 30mm)	4
④		Bolt (M6 x 35mm)	17
⑤		Bolt (M6 x 55mm)	5
⑥		Washer (Ø6,5x14x1mm)	48
⑦		Nut (M6)	5
⑧		Wrench Lock	1
⑨		Allen Wrench	2

Caution: You must read this before you proceed

Please look underneath the Seat Panel for hardware packs

Chair

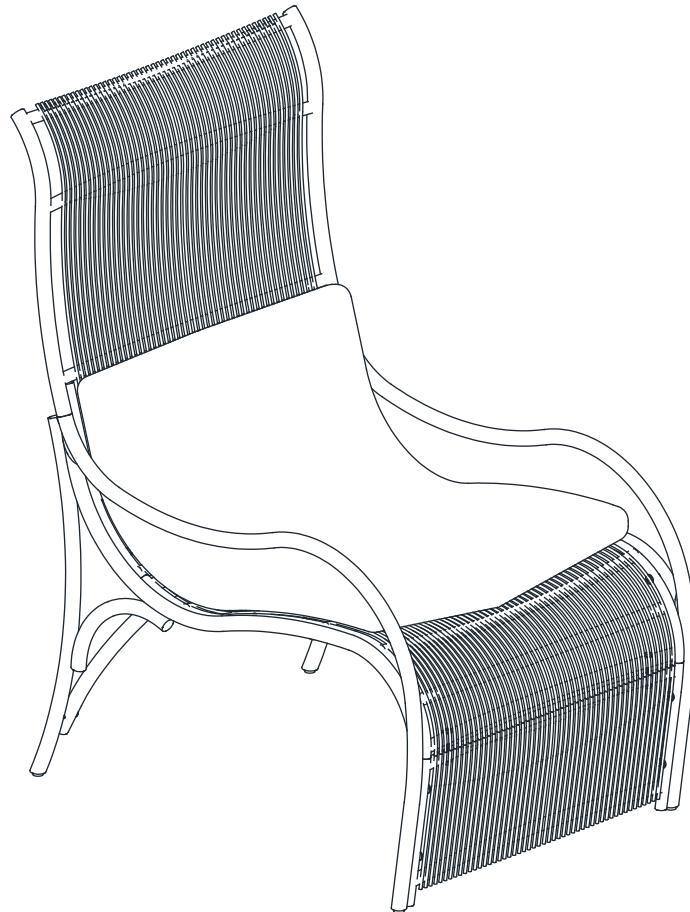

CAUTION: This Chair is NOT a TOY.



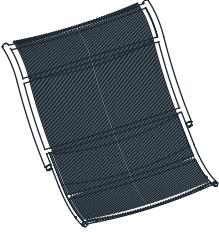
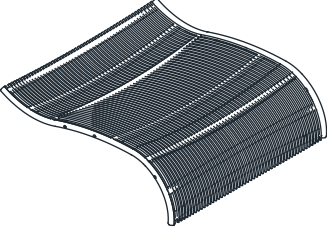
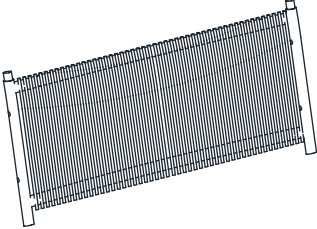
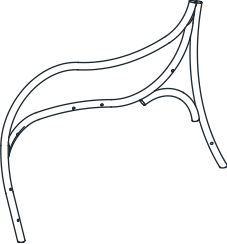
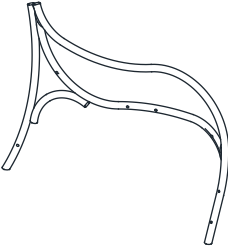
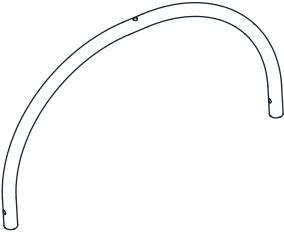
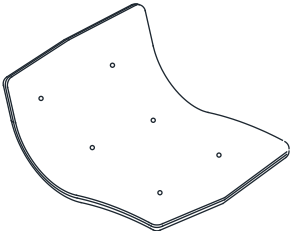

Keep your child / children at bay during the assembly process.

For turning the Chair and to prevent damage to the Chair, 02 persons may be needed to execute this action

Parts List

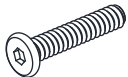
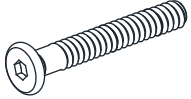
Label	Picture	Description	QTY
A		Back Frame	1
B		Seat Frame	1
C		Front Leg Frame	1
D		Left Arm	1
E		Right Arm	1
F		Leg Stretcher	1
G		Seat Cushion	1

Hardware

Label	Picture	Description	QTY
④		Bolt (M6 x 35mm)	15
⑤		Bolt (M6 x 55mm)	4
⑥		Washer (Ø6,5x14x1mm)	23
⑦		Nut (M6)	4
⑧		Wrench Lock	1
⑨		Allen Wrench	1

Assembly Preparation

Before Beginning Assembly:

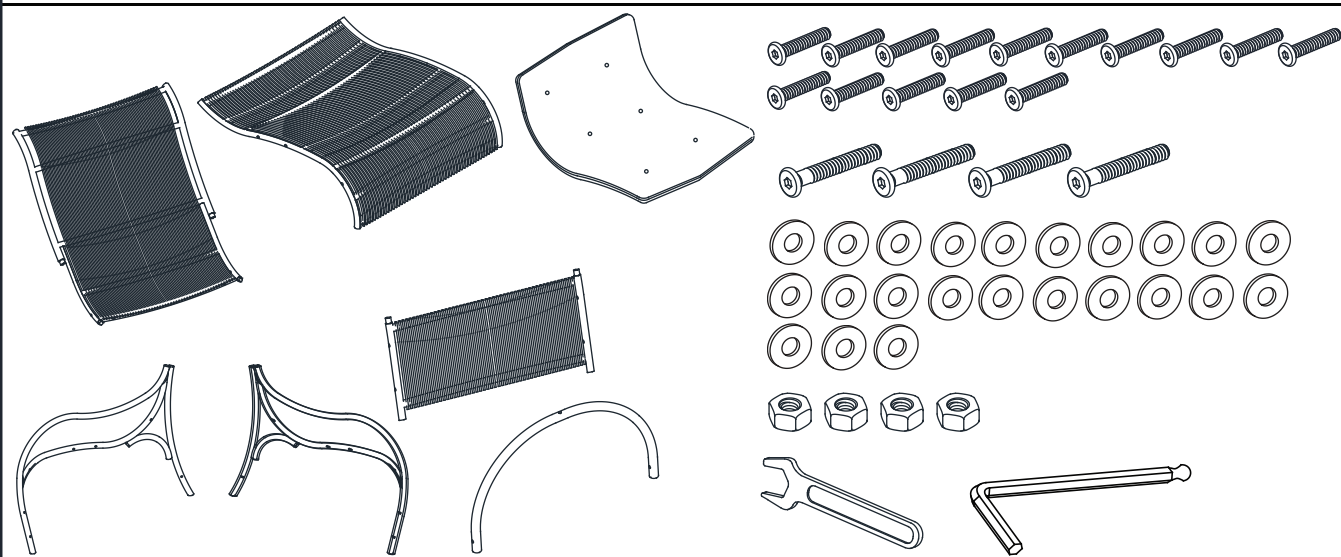

- Read instructions, cover to cover-



- Have 2 adults on hand for assembly-



- Do not assemble on flooring or carpet-



- Assemble on a clean non-marring surface (packing foam)-



- Save all packaging until finished-

Assembly Steps

Overview

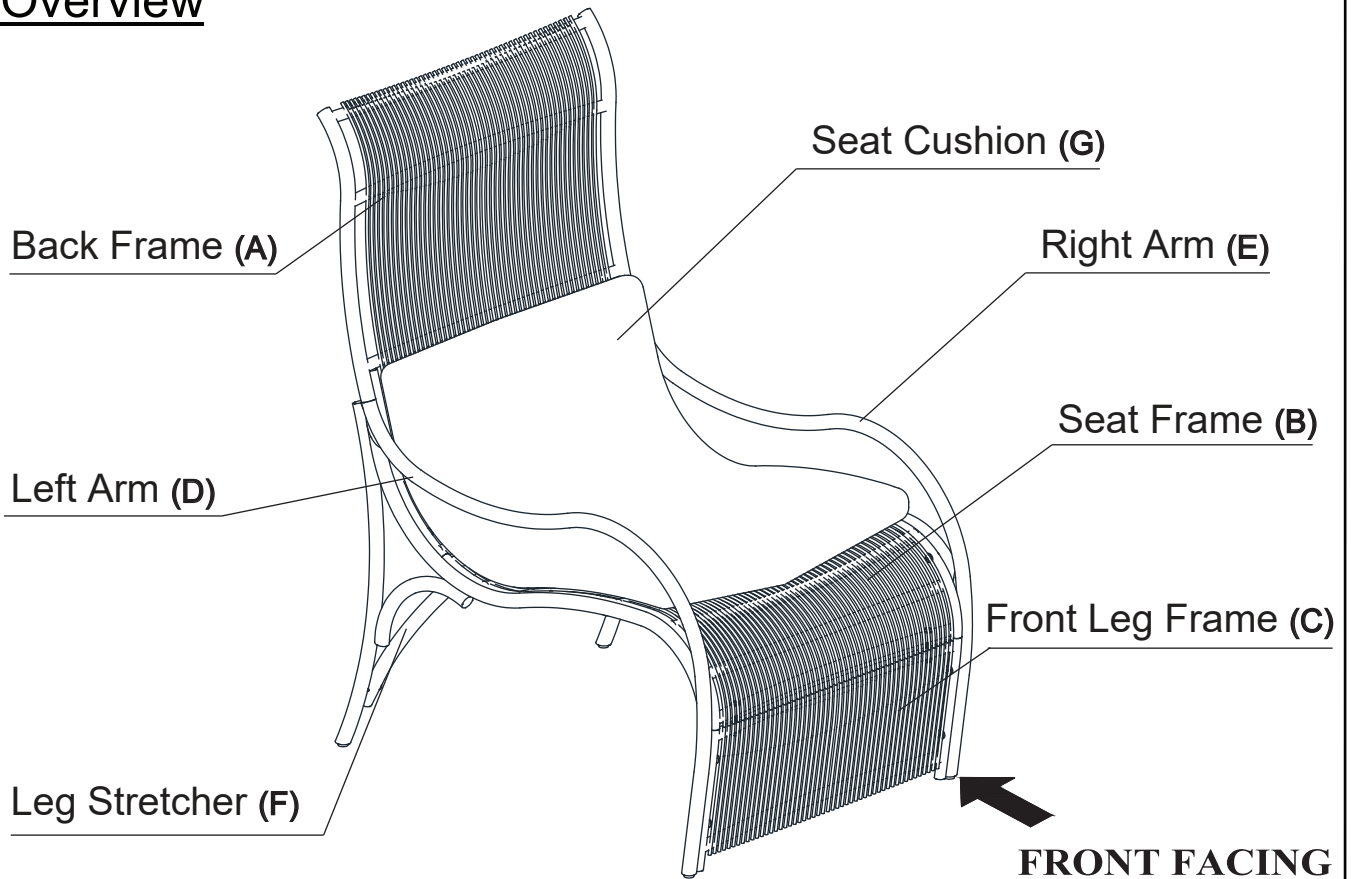

This Chair has multiple parts and may require up to 30 minutes to assemble. To give you an overview of the Chair, the above picture is to help you put the various parts into perspective. Please read through the instructions below to familiarise yourself with the parts and steps before assembly.

Step 1

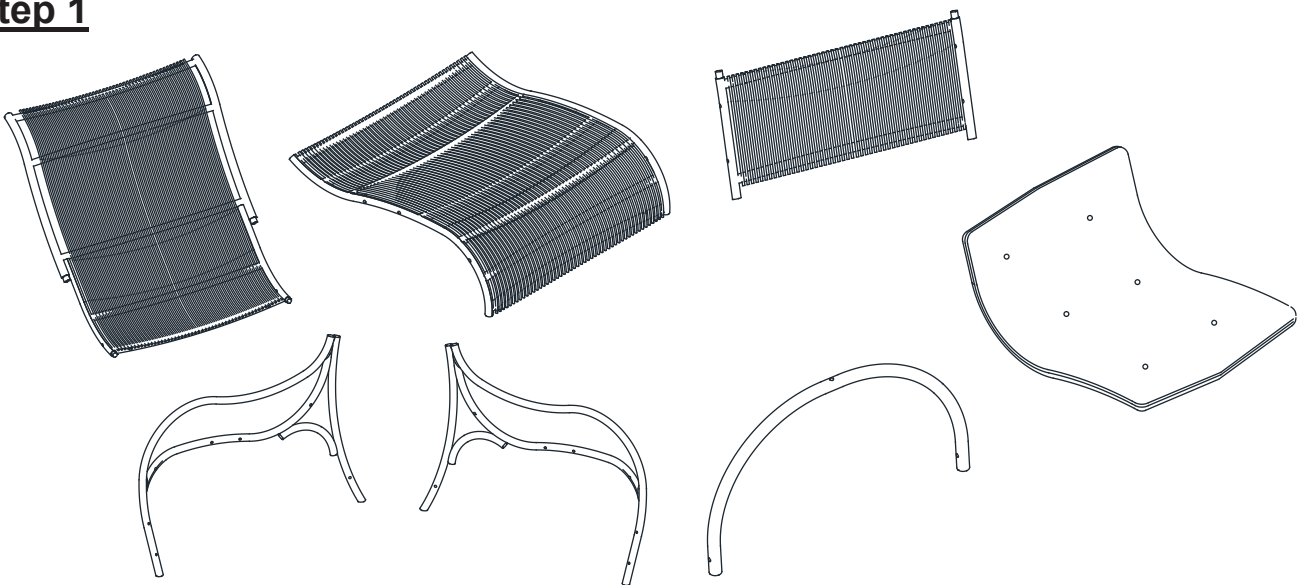

Unpack and place all parts on a clean, non-marring surface.

Step 2

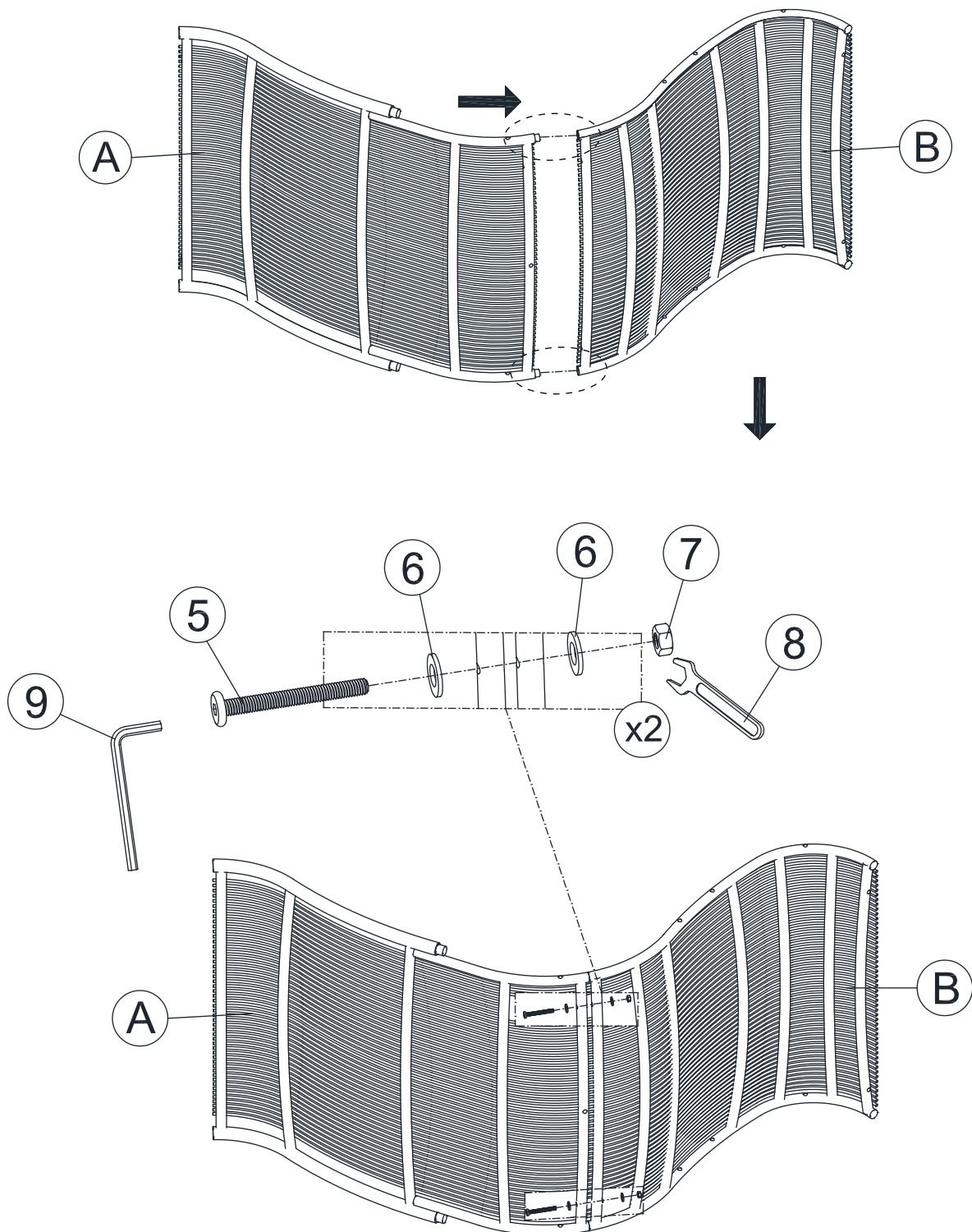

With assistance from your adult partner, please carefully turn Back Frame (A) attach in Seat Frame (B) to fixed position Dowel steel.
Insert Back Frame (A) to Seat Frame (B) by using Bolts (5), Washer (6) and Nut (7) as shown in the above picture.
Do not fully tighten the Bolts.

Step 3

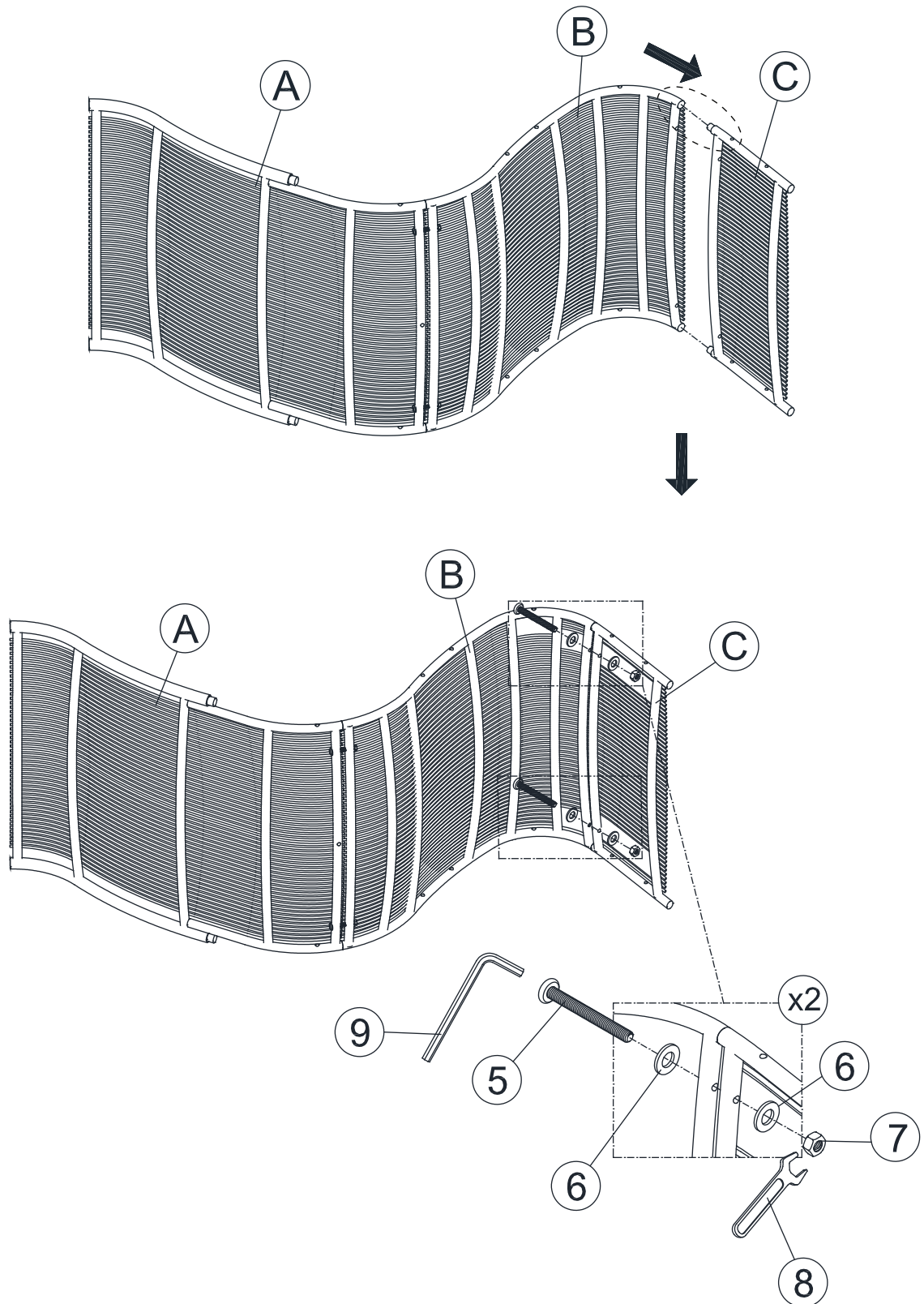

From step 2, attach Front Leg Frame (C) to Seat Frame (B) to fixed position Dowel steel.
Insert Front Leg Frame (C) to Seat Frame (B) by using Bolts (5), Washer (6) and Nut (7) as shown in the above picture.
Do not fully tighten the Bolts.

Step 4

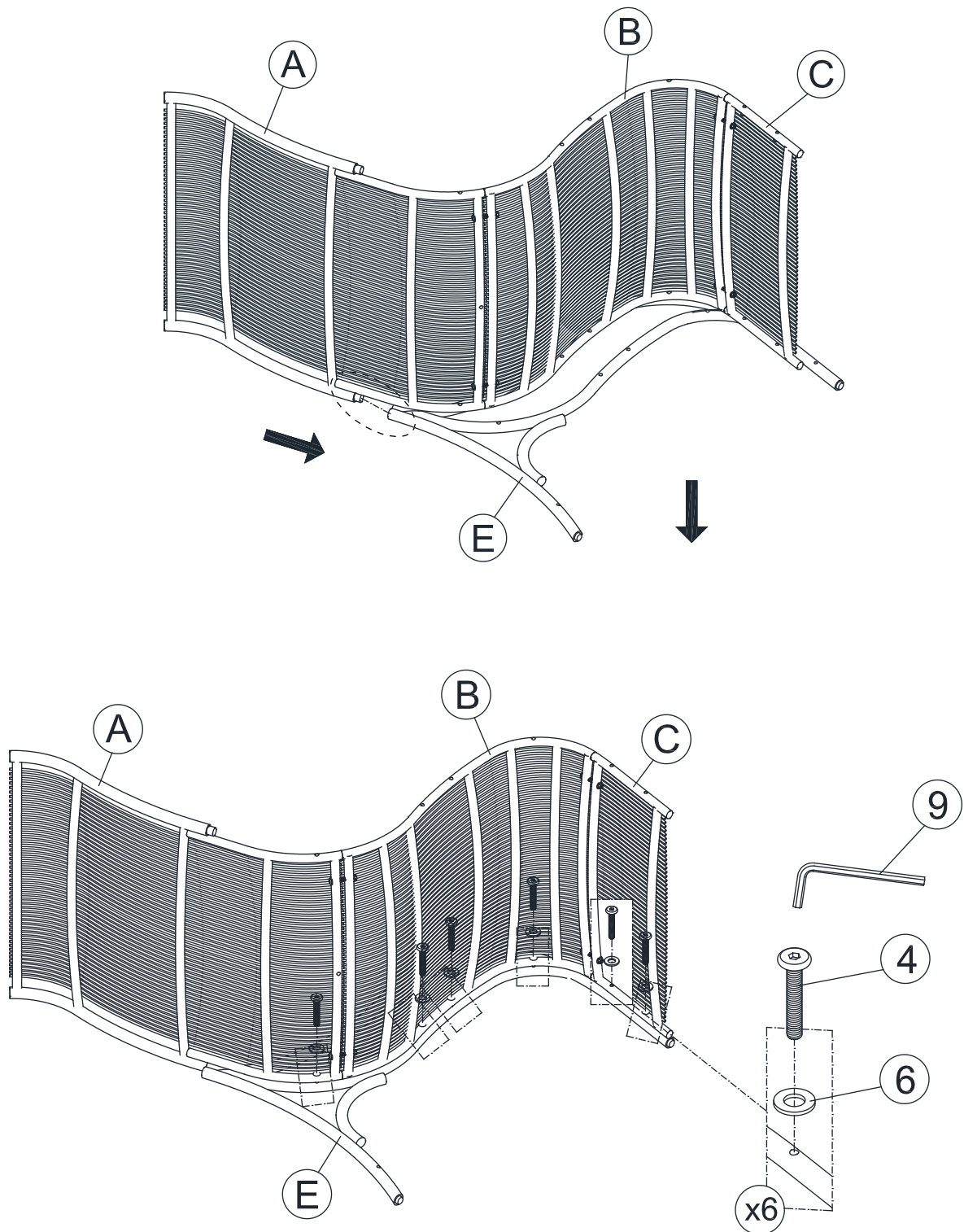

From step 3, attach Right Arm (E) to Back Frame (A) to fixed position Dowel steel.

Insert Right Arm (E) to Back Frame (A), Seat Frame (B) and Front Leg Frame (C) by using Bolts (4) and Washer (6) as shown in the above picture.

Do not fully tighten the Bolts.

Step 5

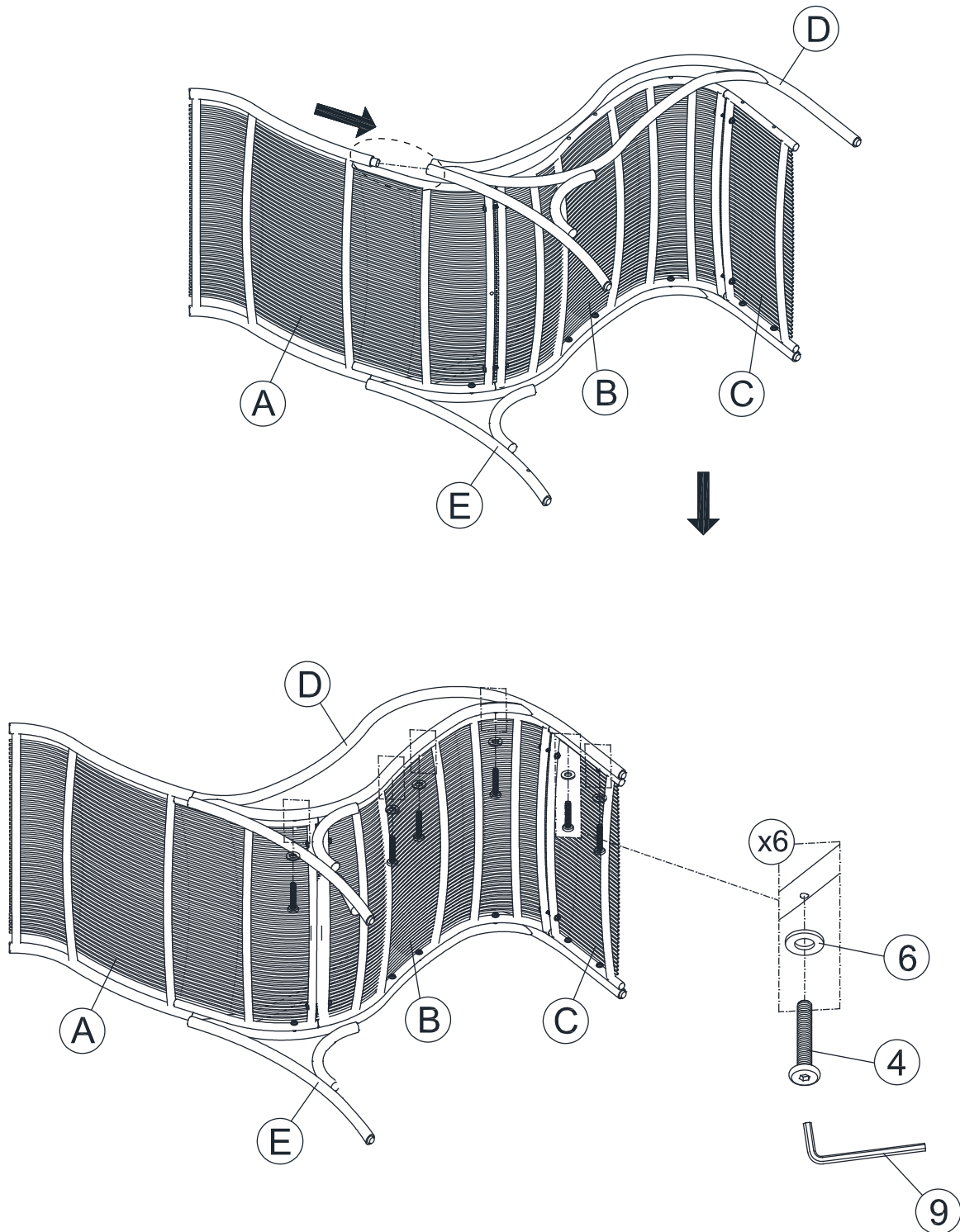

From step 4, attach Left Arm (D) to Back Frame (A) to fixed position Dowel steel.

Insert Left Arm (D) to Back Frame (A), Seat Frame (B) and Front Leg Frame (C) by using Bolts (4) and Washer (6) as shown in the above picture.

Do not fully tighten the Bolts.

Step 6

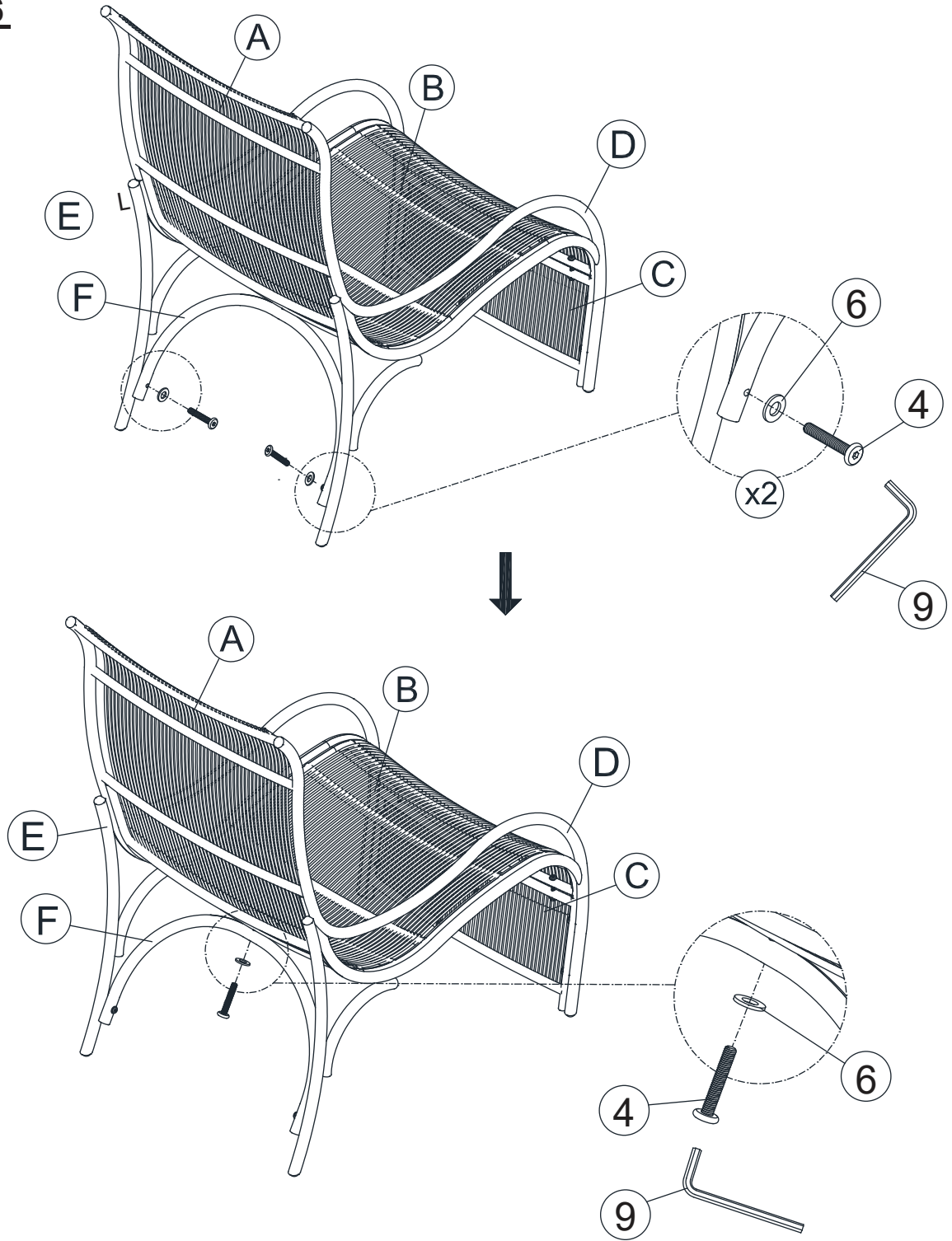

Stand the Chair up in step 5. Attach Leg Stretcher (F) to Right Arm (E) and Left Arm (D) by using Bolts (4) and Washer (6) as shown in the above picture.

Fully tighten the Bolts.

Step 7

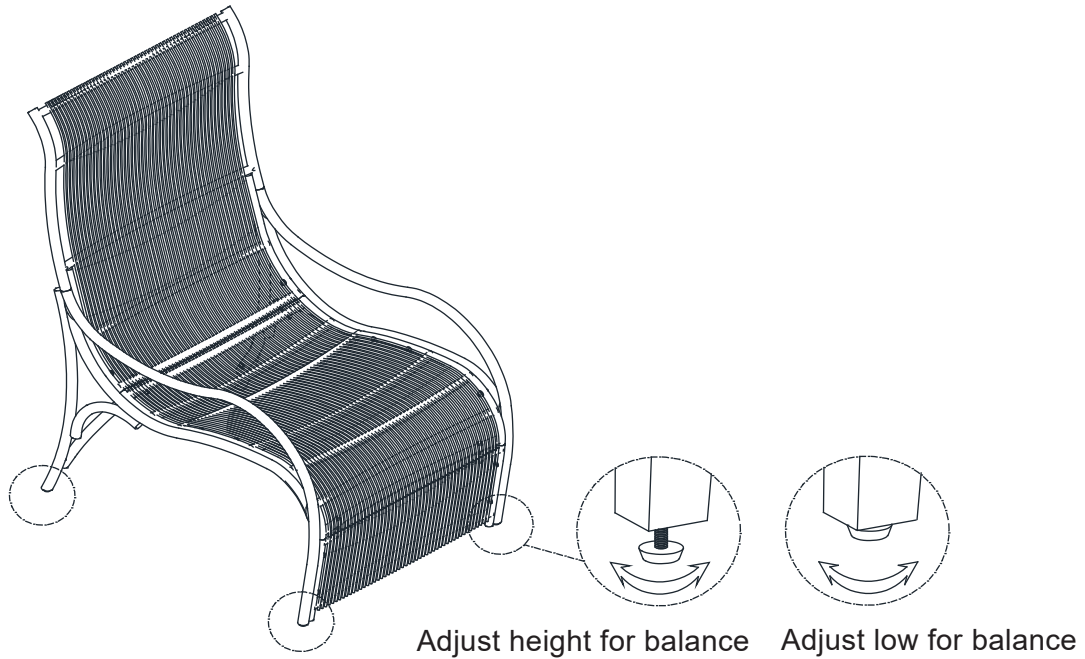

In a sequential manner, tighten all Screws and Bolts at all joints. Place the Chair on a flat, level surface to make sure it is balance. **CAUTION:** When tightening these screws and bolts, tighten sequentially. **DO NOT** tighten any screw or bolt fully and then move towards the next one. This could cause the frame to warp. **WARNING!! IF THE CHAIR IS NOT STABLE , IT COULD LEAD TO DAMAGING THE PRODUCT.** Carefully sit on the Chair. Adjust the Levellers until the Chair is level with the ground.

Step 8

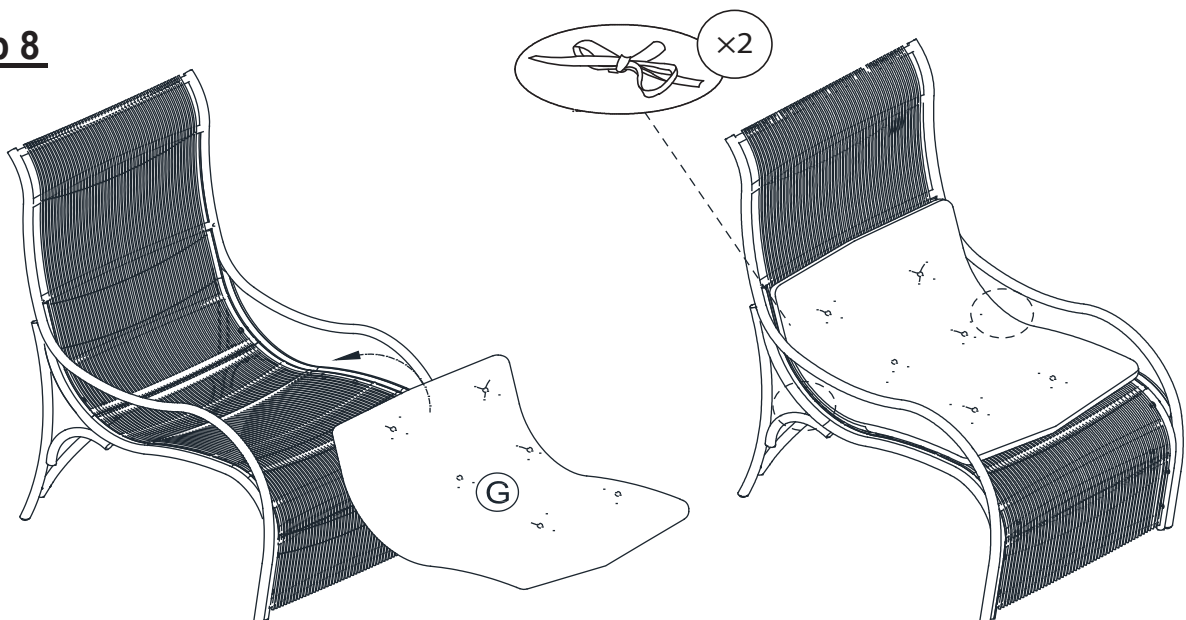

Place the Seat Cushion (G) on the Chair as shown above. Tight Seat Cushion (G) ropes directly to the third support frame which is underneath the Seat Frame (B) . Your Chair is ready to be used.

Caution: You must read this before you proceed

Please look underneath the Seat Panel for hardware packs

OTTOMAN

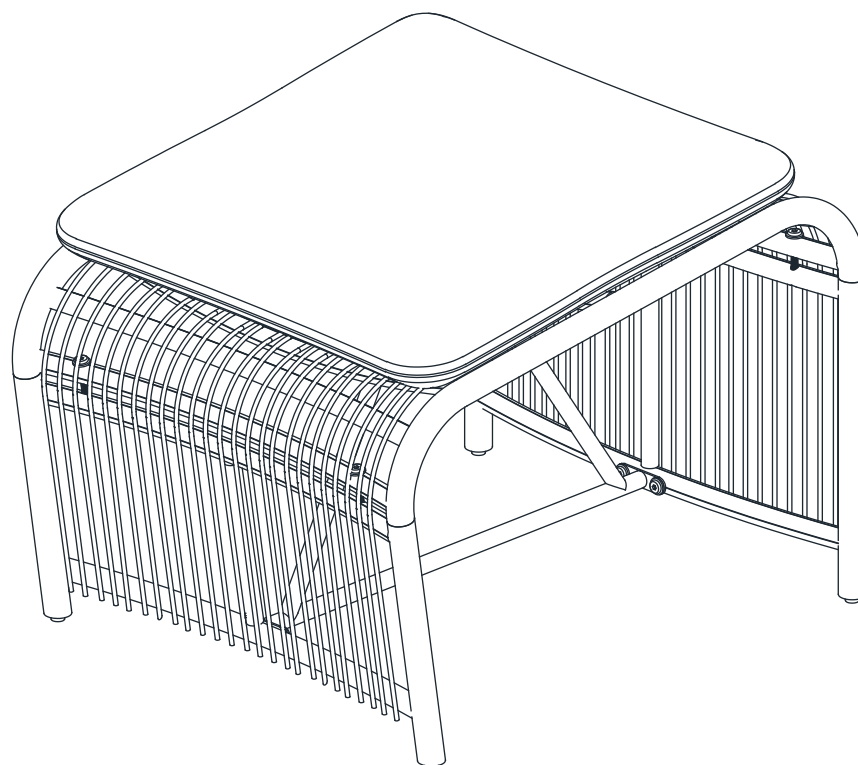



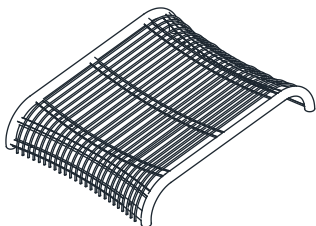
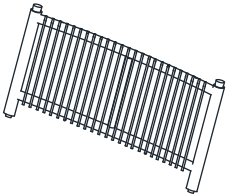
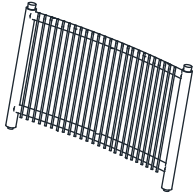
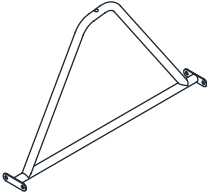
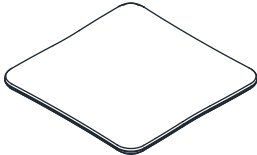

CAUTION: This Ottoman is NOT a TOY.
Keep your child / children at bay during the assembly process.
For turning the Ottoman and to prevent damage to the Ottoman, 02 persons may be needed to execute this action

Parts List

Label	Picture	Description	QTY
H		Seat Frame	1
I		Front Leg Frame	1
J		Back Leg Frame	1
K		Leg Stretcher	1
L		Seat Cushion	1

Hardware

Label	Picture	Description	QTY
①		Bolt (M6 x 15mm)	4
②		Bolt (M6 x 25mm)	1
③		Bolt (M6 x 30mm)	4
⑥		Washer (Ø6,5x14x1mm)	9
⑨		Allen Wrench	1

Assembly Preparation

Before Beginning Assembly:

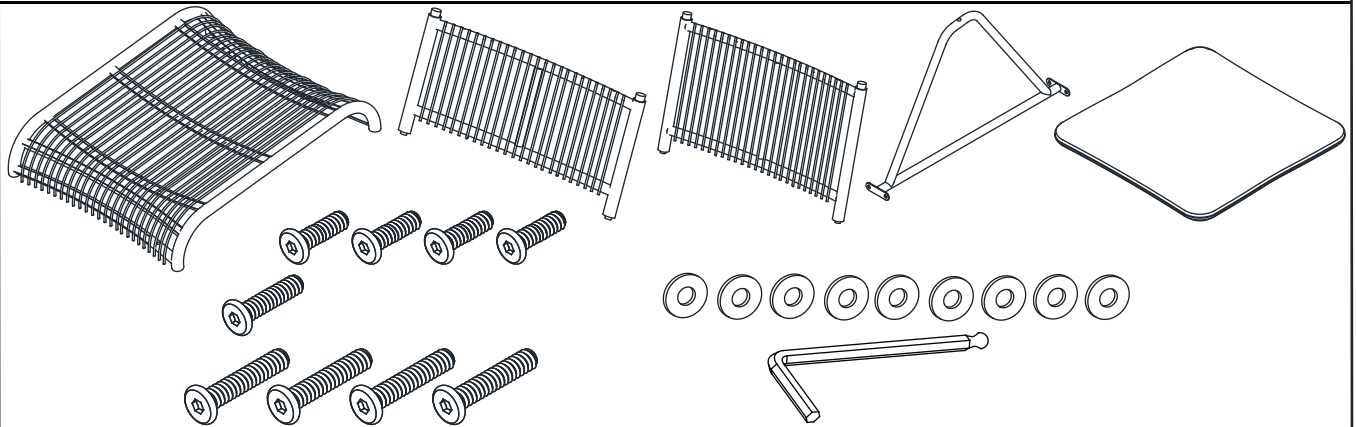

- Read instructions, cover to cover-



- Have 2 adults on hand for assembly-



- Do not assemble on flooring or carpet-



- Assemble on a clean non-marring surface (packing foam)-



- Save all packaging until finished-

Assembly Steps

Overview

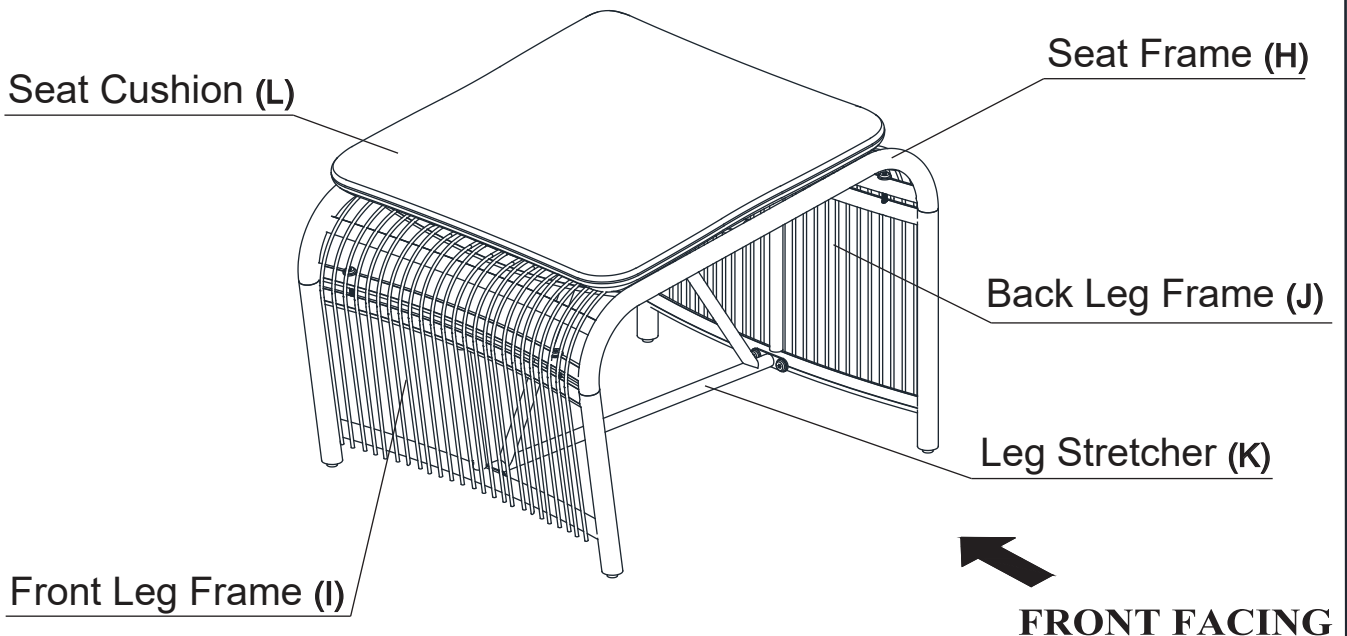

This Ottoman has multiple parts and may require up to 25 minutes to assemble. To give you an overview of the Ottoman, the above picture is to help you put the various parts into perspective. Please read through the instructions below to familiarise yourself with the parts and steps before assembly.

Step 1

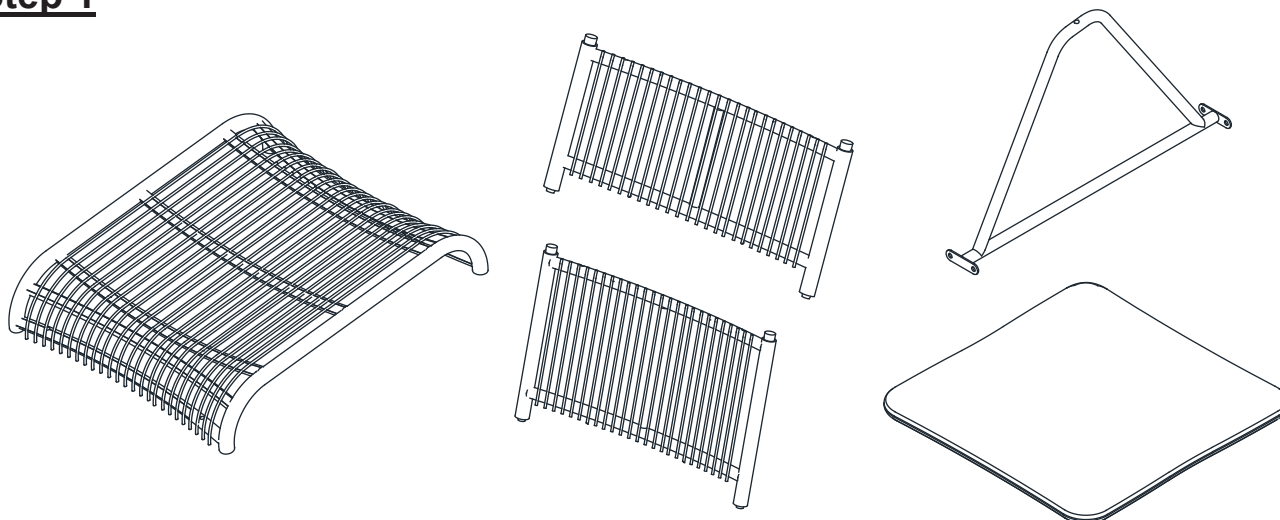

Unpack and place all parts on a clean, non-marring surface.

Step 2

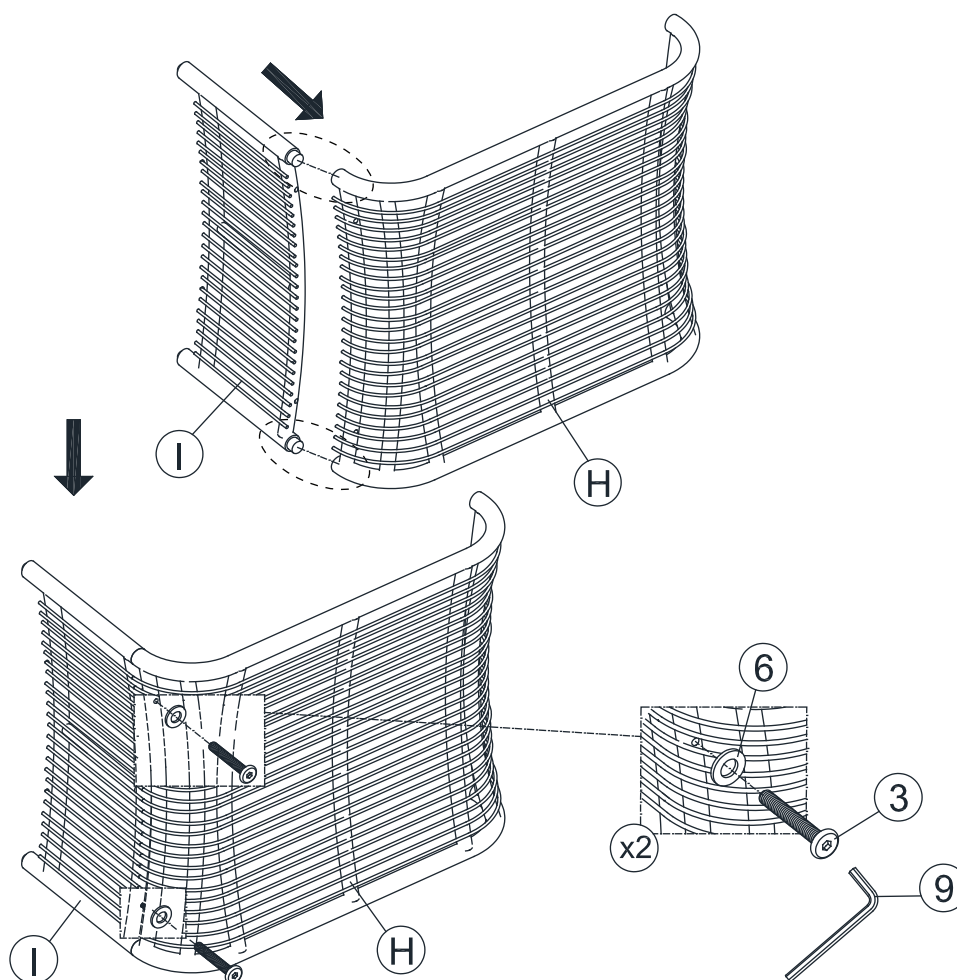

With assistance from your adult partner, please carefully turn Seat Frame (H) attach to Front Leg Frame (I) to fixed position Dowel steel.
Insert Seat Frame (H) to Front Leg Frame (I) by using Bolts (3) and Washer (6) as shown in the above picture.
Do not fully tighten the Bolts.

Step 3

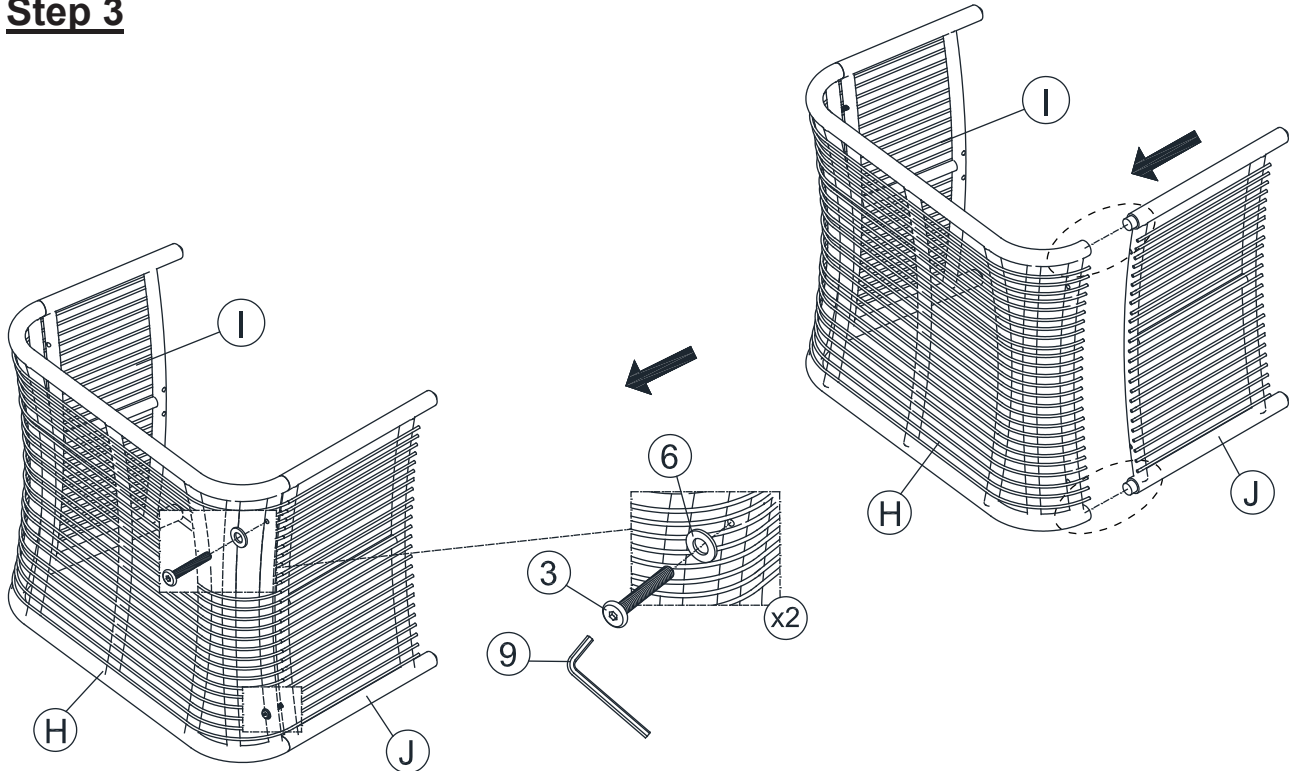

From step 2, attach Seat Frame (H) to Back Leg Frame (J) to fixed position Dowel steel.

Insert Seat Frame (H) to Back Leg Frame (J) by using Bolts (3) and Washer (6) as shown in the above picture.

Do not fully tighten the Bolts.

Step 4

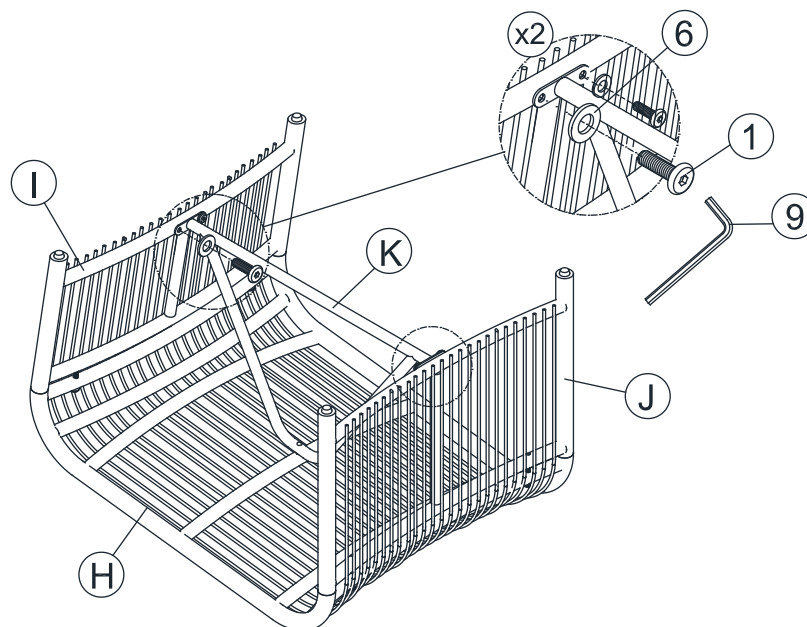

From step 3, please carefully upside down Seat Frame. Insert Leg Stretcher (K) to Front Leg Frame (I) and Back Leg Frame (J) by using Bolts (1) and Washer (6) as shown in the above picture.

Do not fully tighten the Bolts.

Step 5

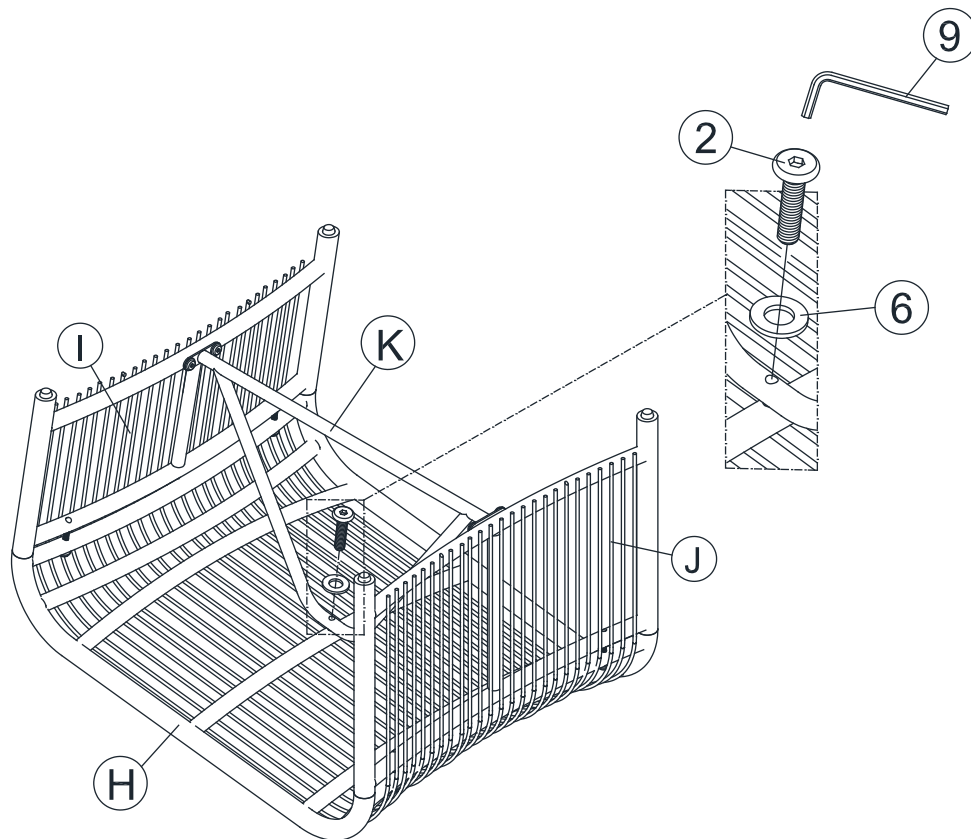

From step 4, Insert Leg Stretcher (K) to Seat Frame (H) by using Bolts (2) and Washer (6) as shown in the above picture.
Fully tighten the Bolts.

Step 6

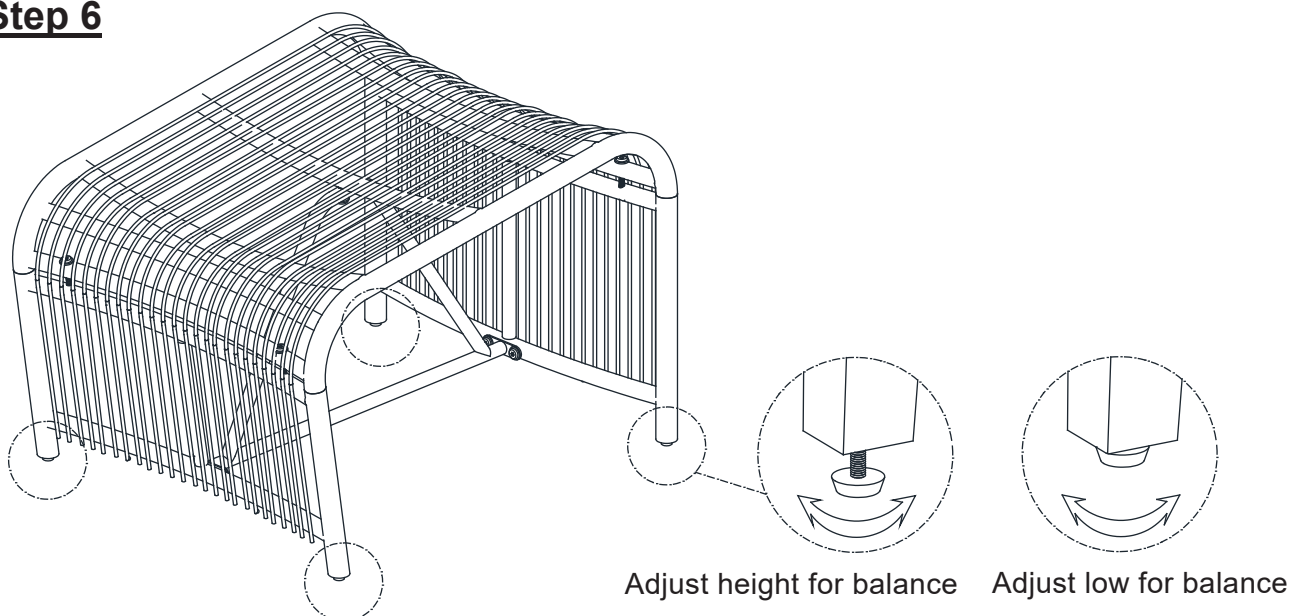

Stand the Chair up in step 5. Carefully sit on the Ottoman. Adjust the Levellers until the Ottoman is level with the ground.

Step 7

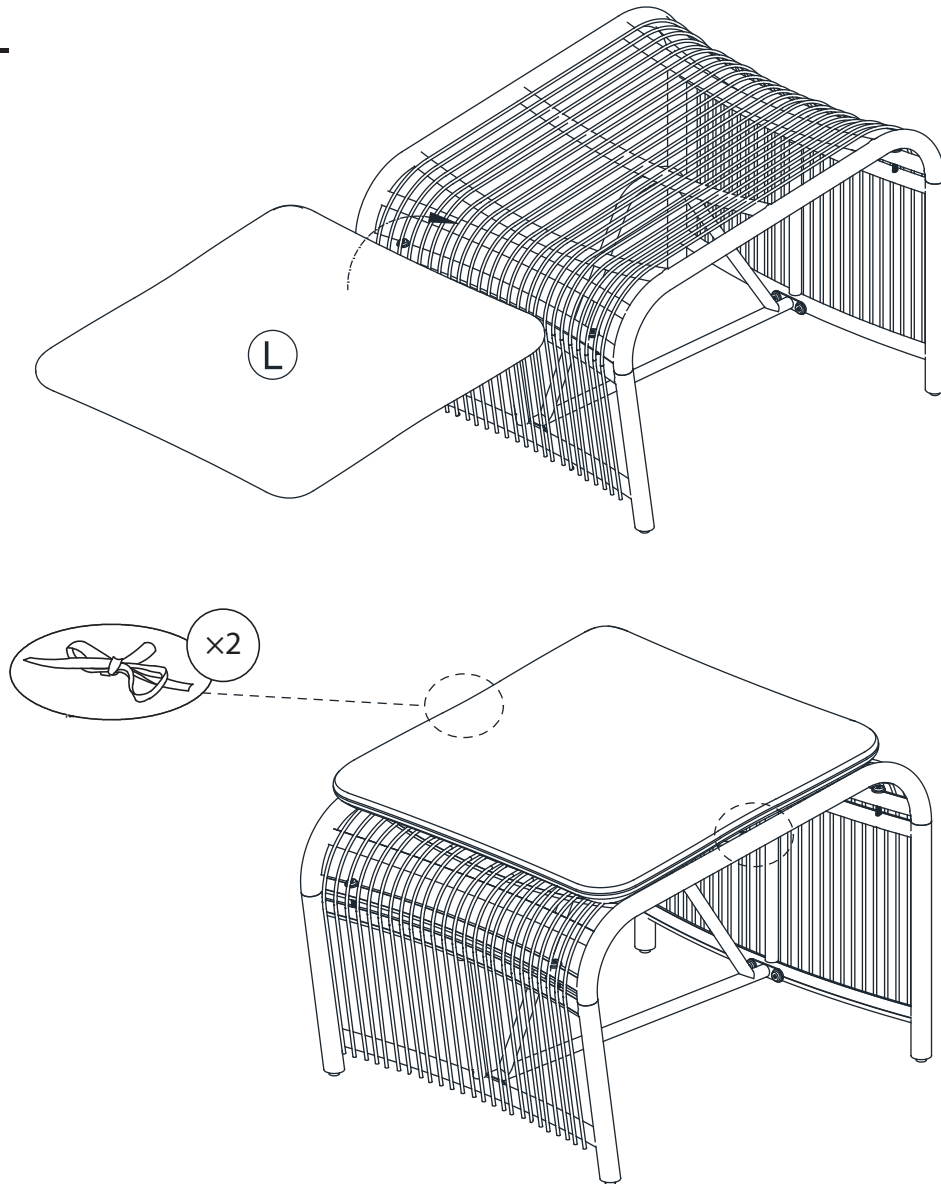

In a sequential manner, tighten all Screws and Bolts at all joints.
Place the Ottoman on a flat, level surface to make sure it is balance.
CAUTION: When tightening these screws and bolts, tighten sequentially.
DO NOT tighten any screw or bolt fully and then move towards the next one.
This could cause the frame to warp.

WARNING!! IF THE CHAIR IS NOT STABLE , IT COULD LEAD TO DAMAGING THE PRODUCT.

Place the Seat Cushion (L) on the Chair as shown above.

Tight Seat Cushion (L) ropes directly to the frame underneath the Seat Frame (H) .

Your Chair is ready to be used.

Caution: You must read this before you proceed

Please look underneath the Seat Panel for hardware packs

TABLE

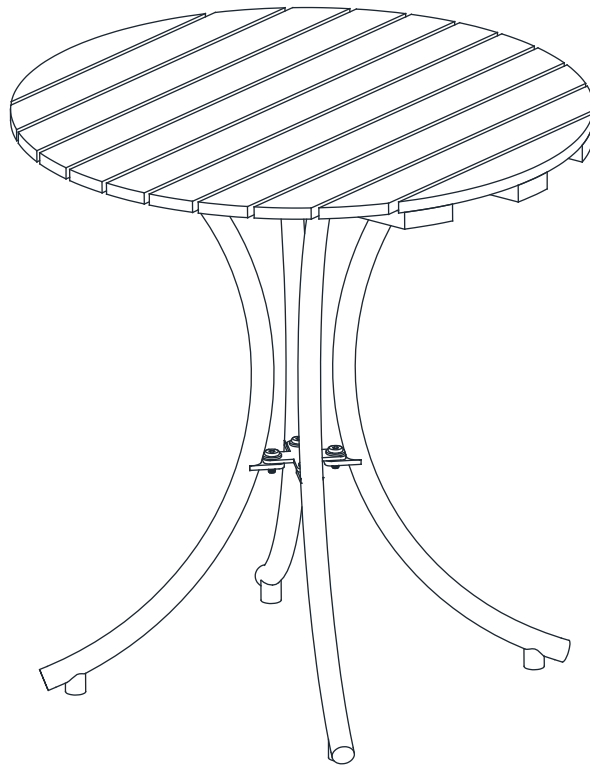

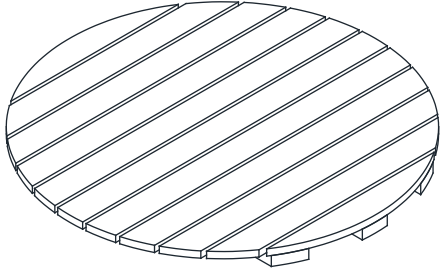
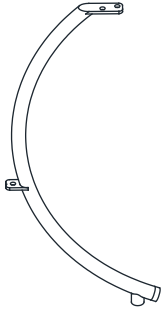
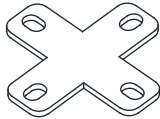

CAUTION: This Table is NOT a TOY.
Keep your child / children at bay during the assembly process.
For turning the Table and to prevent damage to the Table, 02 persons may be needed to execute this action

Parts List

Label	Picture	Description	QTY
M		Table Top	1
N		Leg	4
O		Iron Plate	1

Hardware

Label	Picture	Description	QTY
①		Bolt (M6 x 15mm)	12
⑥		Washer (Ø6,5x14x1mm)	12
⑨		Allen Wrench	1

Assembly Preparation

Before Beginning Assembly:

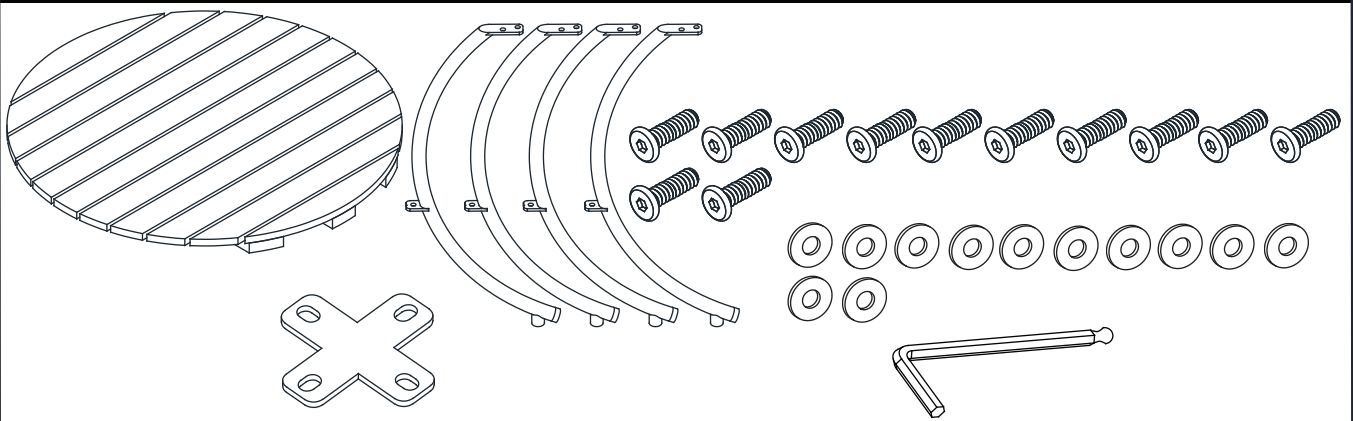

- Read instructions, cover to cover-



- Have 2 adults on hand for assembly-



- Do not assemble on flooring or carpet-



- Assemble on a clean non-marring surface (packing foam)-



- Save all packaging until finished-

Assembly Steps

Overview

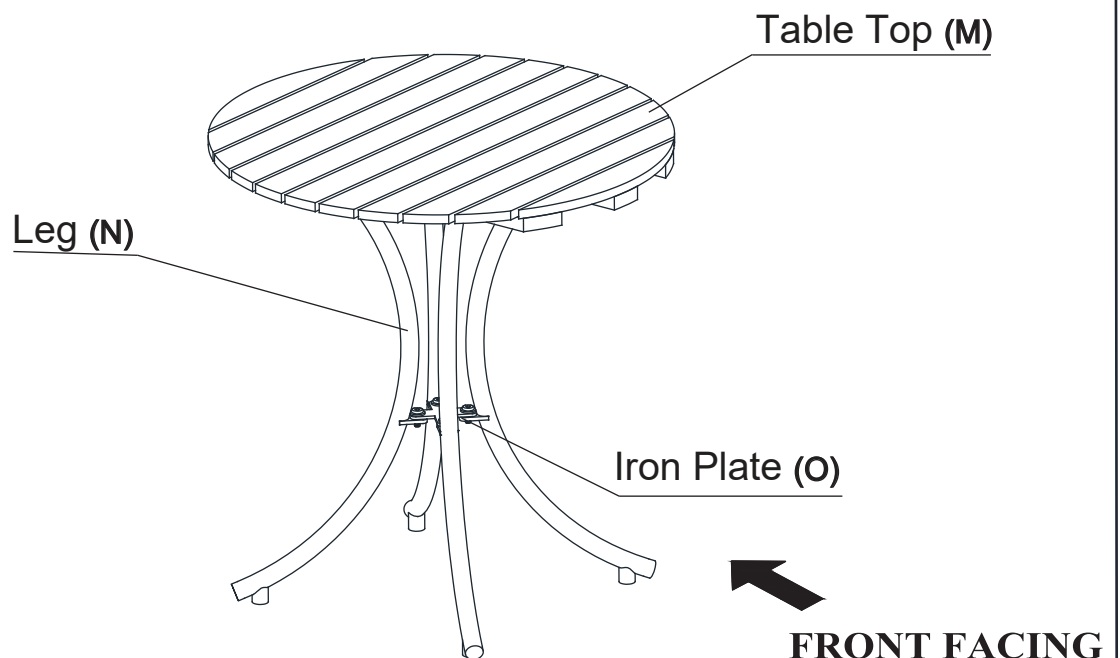

This Table has multiple parts and may require up to 25 minutes to assemble. To give you an overview of the Table the above picture is to help you put the various parts into perspective. Please read through the instructions below to familiarise yourself with the parts and steps before assembly.

Step 1

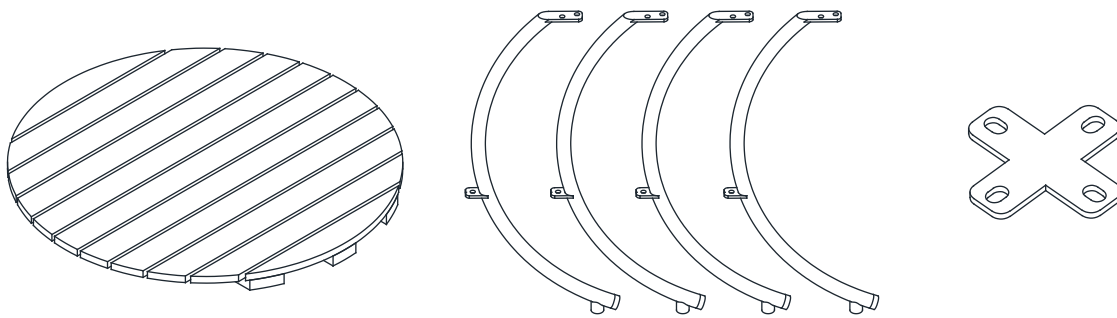

Unpack and place all parts on a clean, non-marring surface.

Step 2

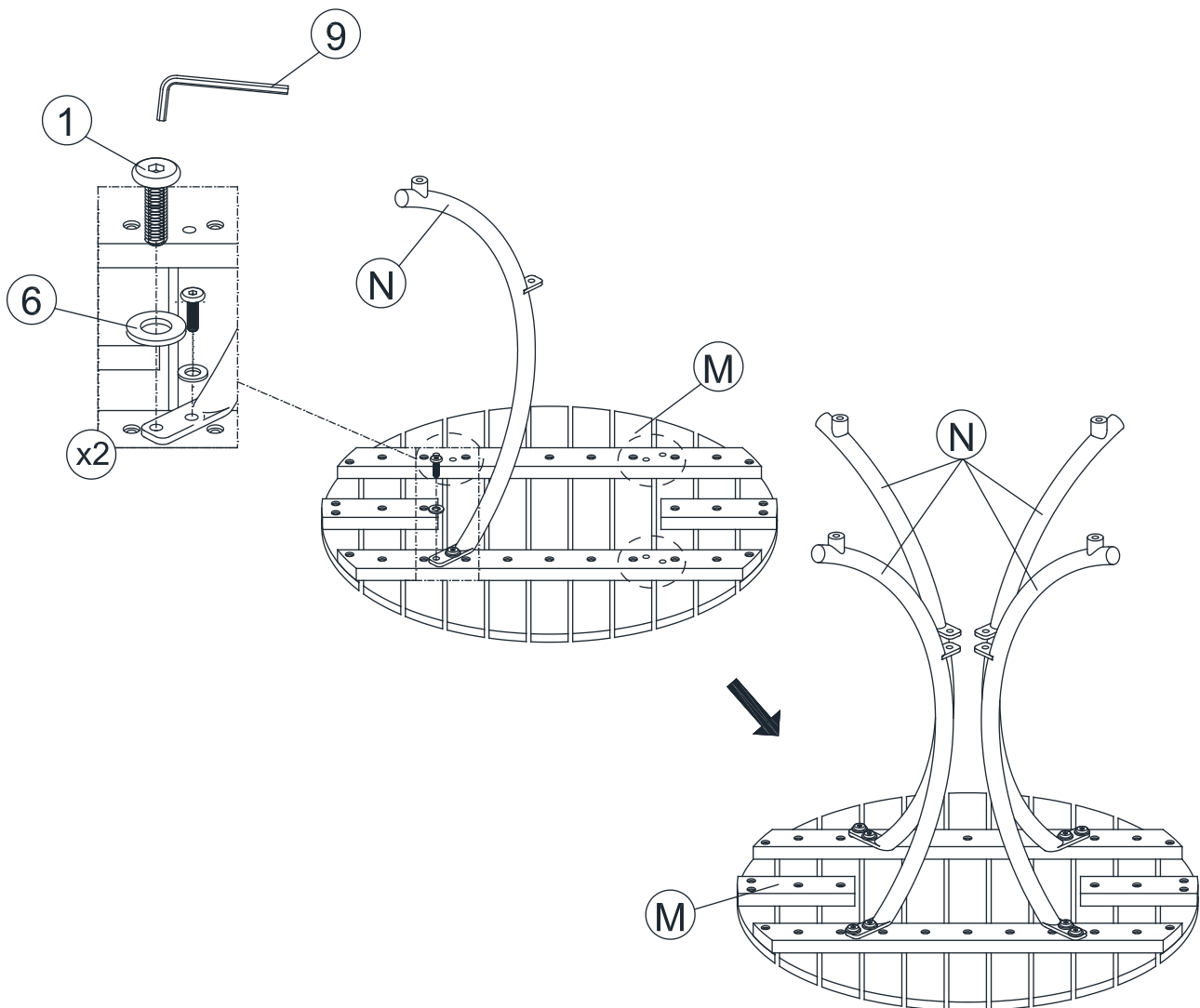

With assistance from your adult partner, please carefully upside down Table Top (M). Insert Leg (N) to Table Top (M) by using Bolts (1) and Washer (6) as shown in the above picture.

Do not fully tighten the Bolts.

Step 3

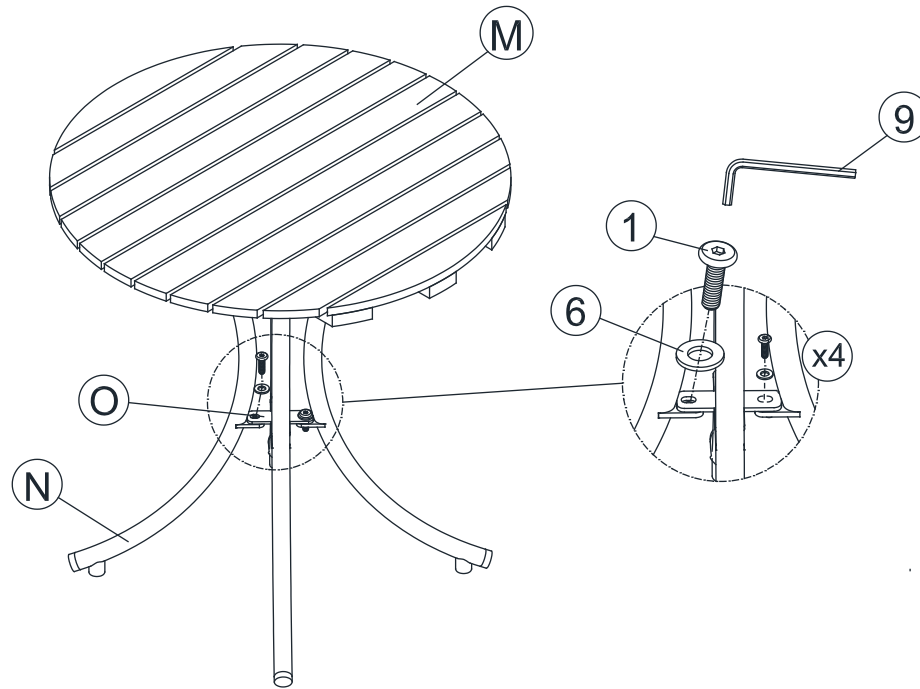

Stand the Chair up in step 2, attach Iron Plate (O) to Leg (N) to fixed position by using Bolts (1) and Washer (6) as shown in the above picture. **Fully tighten the Bolts.**

Step 4

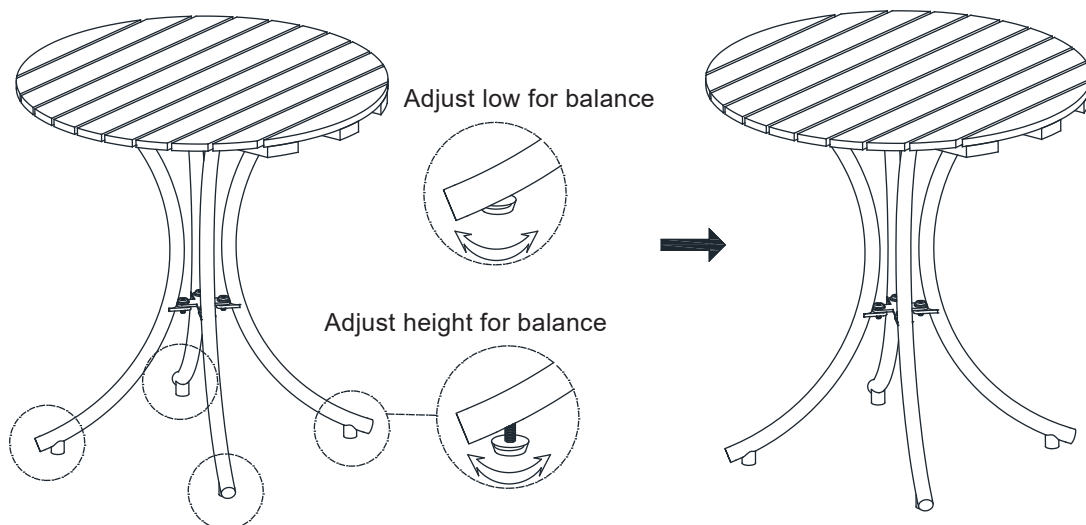

In a sequential manner, tighten all Screws and Bolts at all joints. Place the Table on a flat, level surface to make sure it is balance. **CAUTION:** When tightening these screws and bolts, tighten sequentially. **DO NOT** tighten any screw or bolt fully and then move towards the next one. This could cause the frame to warp. **WARNING!! IF THE CHAIR IS NOT STABLE , IT COULD LEAD TO DAMAGING THE PRODUCT.** Adjust the levers at the bottom of the legs (if needed) to balance the Table. Your Table is ready to be used. This table can only used on a flat, level surface.

Questions & Answers about Proposition 65

- What is Proposition 65?

Proposition 65 requires businesses to provide warnings to Californians about significant exposures to chemicals that cause cancer, birth defects or other reproductive harm. These chemicals can be in the products that Californians purchase, in their homes or workplaces, or that are released into the environment. By requiring that this information be provided, Proposition 65 enables Californians to make informed decisions about their exposures to these chemicals. Proposition 65 also prohibits California businesses from knowingly discharging significant amounts of listed chemicals into sources of drinking water.

Proposition 65 requires California to publish a list of chemicals known to cause cancer, birth defects or other reproductive harm. This list, which must be updated at least once a year, has grown to include approximately 900 chemicals since it was first published in 1987.

- What types of chemicals are on the Proposition 65 list?

The list contains a wide range of naturally occurring and synthetic chemicals that include additives or ingredients in pesticides, common household products, food, drugs, dyes, or solvents. Listed chemicals may also be used in manufacturing and construction, or they may be byproducts of chemical processes, such as motor vehicle exhaust.

- What does a warning mean?

If a warning is placed on a product label or posted or distributed at a workplace, a business, or in rental housing, the business issuing the warning is aware or believes that it is exposing individuals to one or more listed chemicals.

By law, a warning must be given for listed chemicals unless the exposure is low enough to pose no significant risk of cancer or is significantly below levels observed to cause birth defects or other reproductive harm.

- Where can I get more information on Proposition 65?

If you have specific questions on the administration or implementation of Proposition 65, you can contact OEHHA's Proposition 65 program at P65.Questions@oehha.ca.gov, or by phone at (916) 445-6900.