

HAPPINESS HAPPINESS INSTALLATION



CAUTION

Parts are placed at the bottom of the product.

- If you have any questions with the product, please contact us by:
- **Email: customerservice@zoy-living.com**
(we will reply to you within 24 hours)

Assembly Instructions

Model: RR5648AF

CAUTION







DO NOT use any sharp objects to open plastic wrapped components as this may result damage to product or components .

Your Loveseat or sofa comes packaged in THREE boxes.

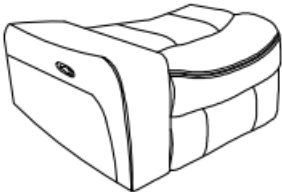
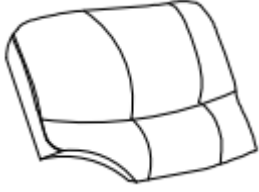
(Loveseat: **Box1&Box 2& Box3**; Sofa: **Box1&Box3&Box4**)

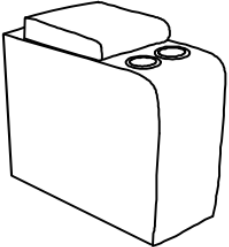
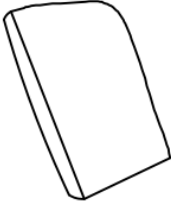
Carefully remove all components from the packaging and set them aside for assembly.

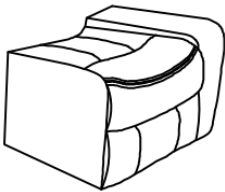
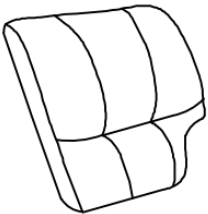
Package Contents

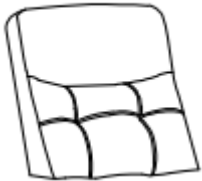
BOX 1 RR5648AF51L				
	A Left Seat*1	B Left Back*1	C Left Armrest*1	
BOX 2 RC5648AF61N				
	D Storage Base*1	E Storage Back*1	F Latches*2	
BOX 3 RR5648AF51R				
	G Right Seat*1	H Right Back*1	I Right Armrest*1	
BOX 4 RS5648AF61NB				
	K Middle Seat*1	J Middle Back*1		

1 RECLINER ASSEMBLY - BODY SETUP

STEP1:

As shown in the picture, first zip up the **Armrest (C&I)** to secure it to the armrest, and then firmly attach the Velcro strip on the inside of the armrest cushion.

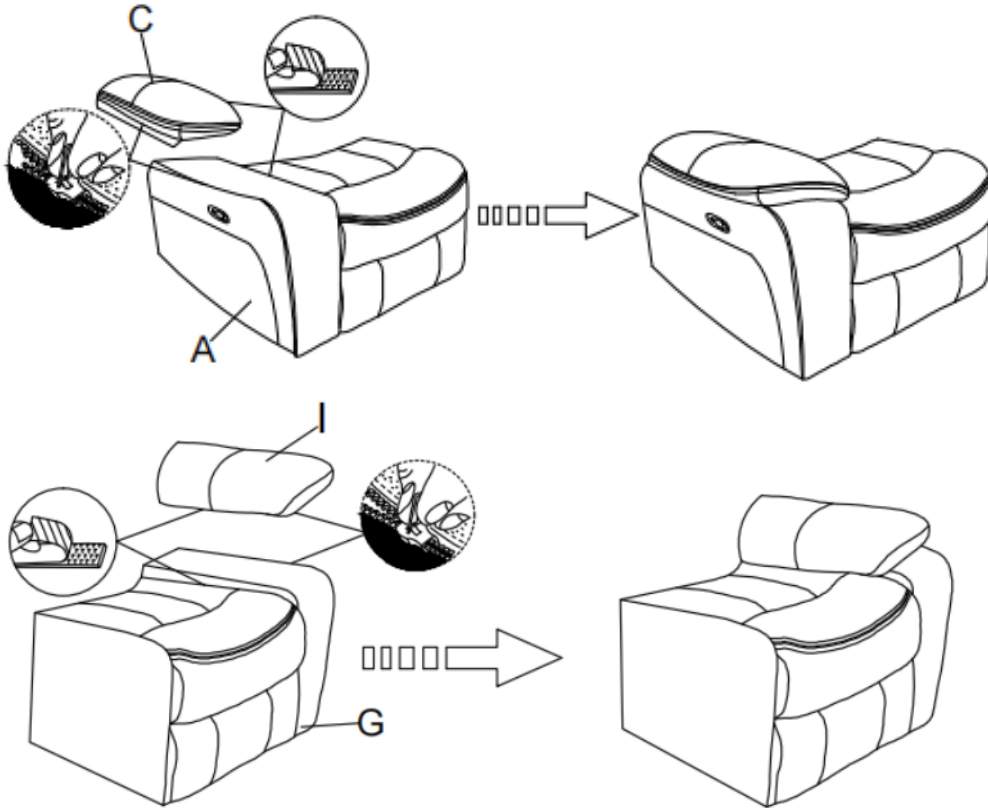

STEP2:

The Storage Back(E) is placed in the Storage Base(D).

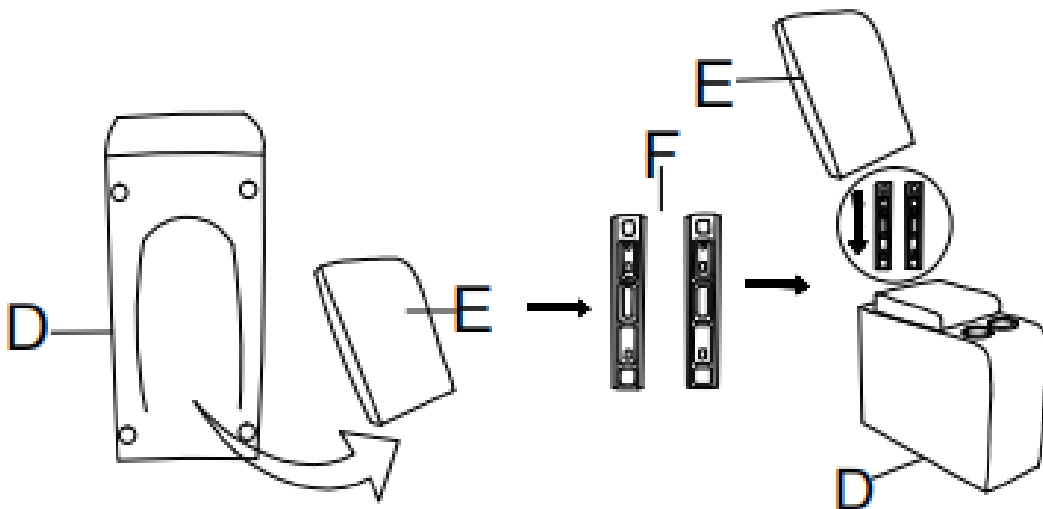

Note: The 2 latches(F) should be inserted into Storage (E) before installation.

2 RECLINER ASSEMBLY - BODY SETUP

STEP3:

Attach Back(B&E&J&H)to Seat(A&D&K&G) by aligning the metal sliders. And connect the parts of the sectional assembly by means of the metal grooves at the bottom.

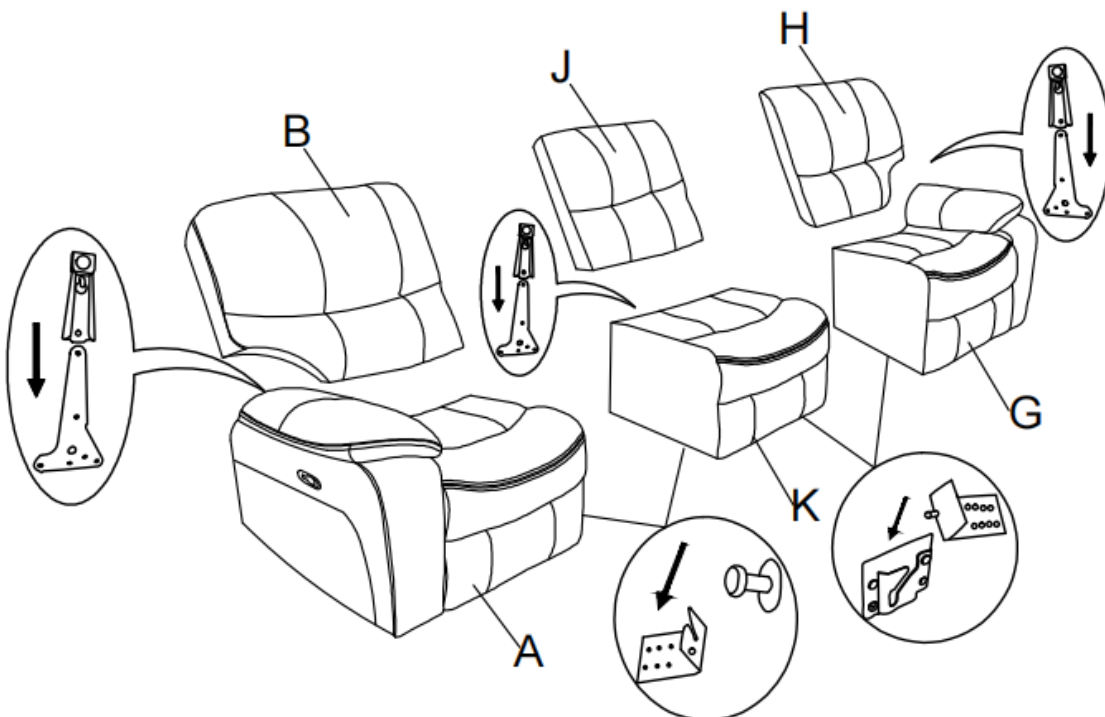
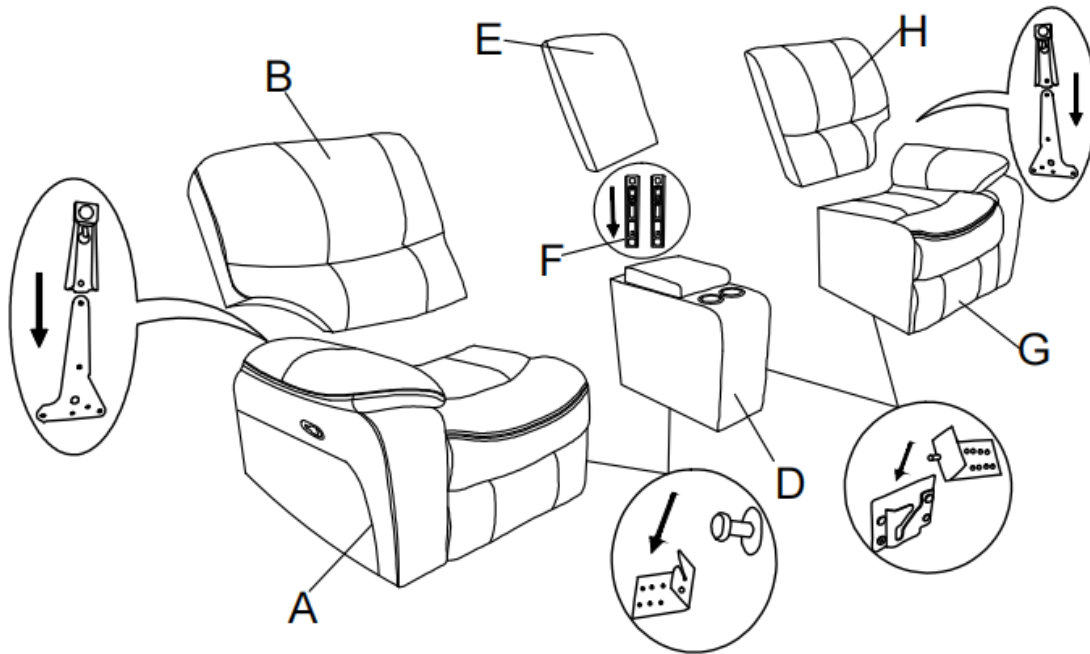

3 RECLINER ASSEMBLY - BODY SETUP

ASSEMBLY COMPLETED

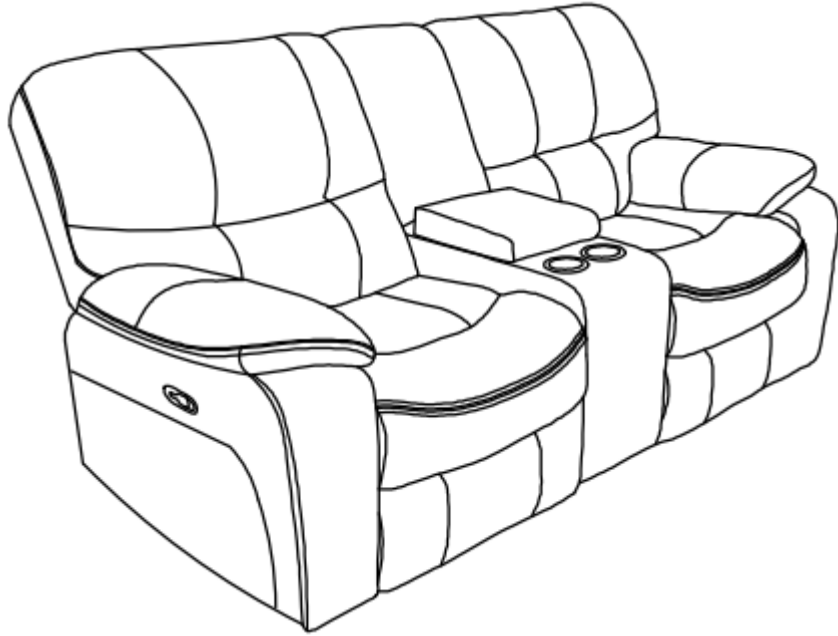

ASSEMBLY COMPLETED

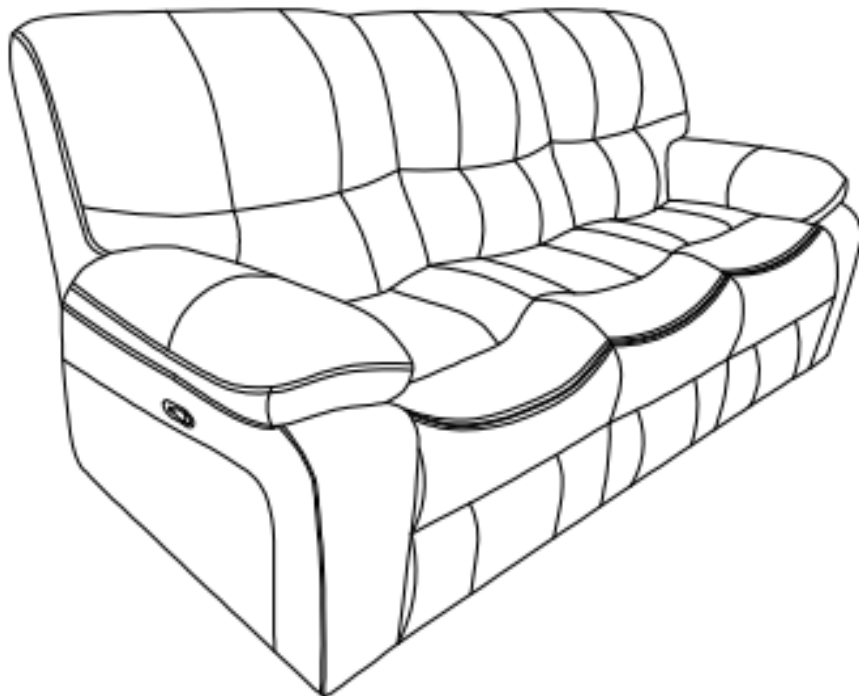

4 RECLINER ASSEMBLY - BODY SETUP

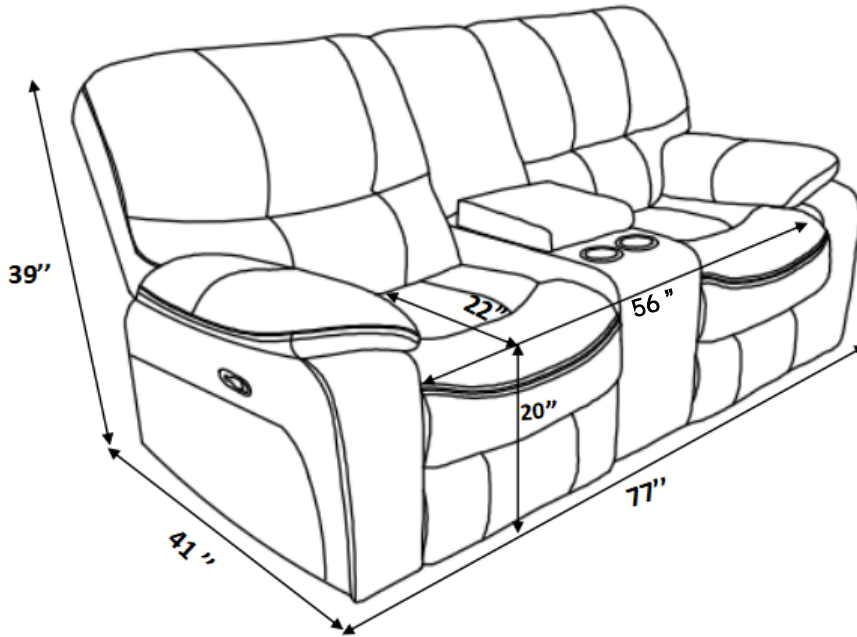

Loveseat

RR5648AF51L+RC5648AF61N+RR5648AF51R

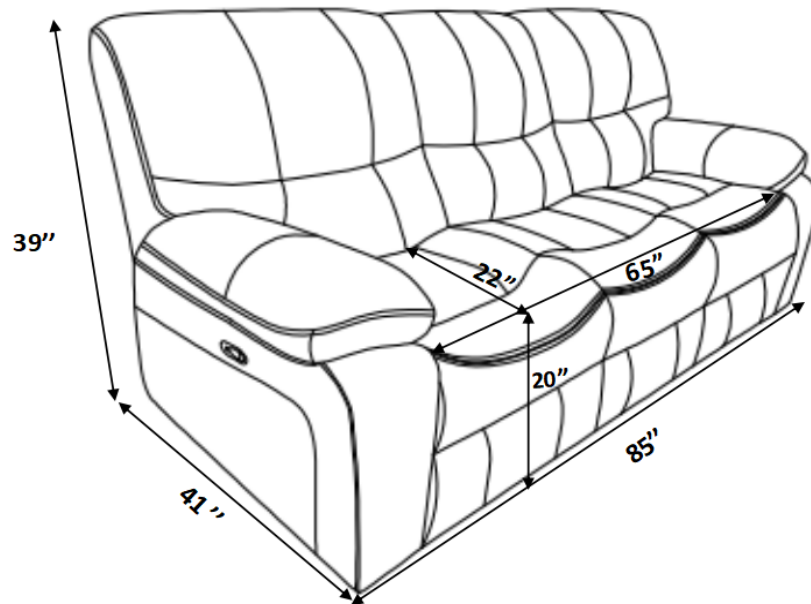

Sofa

RR5648AF51L+RS5648AF61NB+RR5648AF51R

⚠️ WARNINGS

1. Please check if the components of the chair are all included and can be used normally.
2. Assemble all components according to the instruction correctly before you sit in the sofa.
3. Please DO NOT sit on the armrests or footrest to eliminate the risk of tipping over.
4. If the chair is damaged or doesn't match the website description, please send clear pictures of the product and label of the carton to our service team for further help.
5. If the recliner doesn't work, you may try the following measures for self-checking firstly:
 - a) check if all the cables are connected;
 - b) check if the light of transformer is on.

If the chair still doesn't work, please feed the information back to our customer service in time and we will help you solve the matter as soon as possible.

6. If you have any questions about our products, please contact us by:

Email: customerservice@zoy-living.com (we will respond to your inquiry within 24 hours)

