

**ASSEMBLY INSTRUCTIONS**  
**Item No: WF306388AAE-WF306388AAD**  
**Description: Dining Table**

Thank you for purchasing this quality product. Be sure to check all packing material carefully for small part that may have come loose inside the carton during shipment.

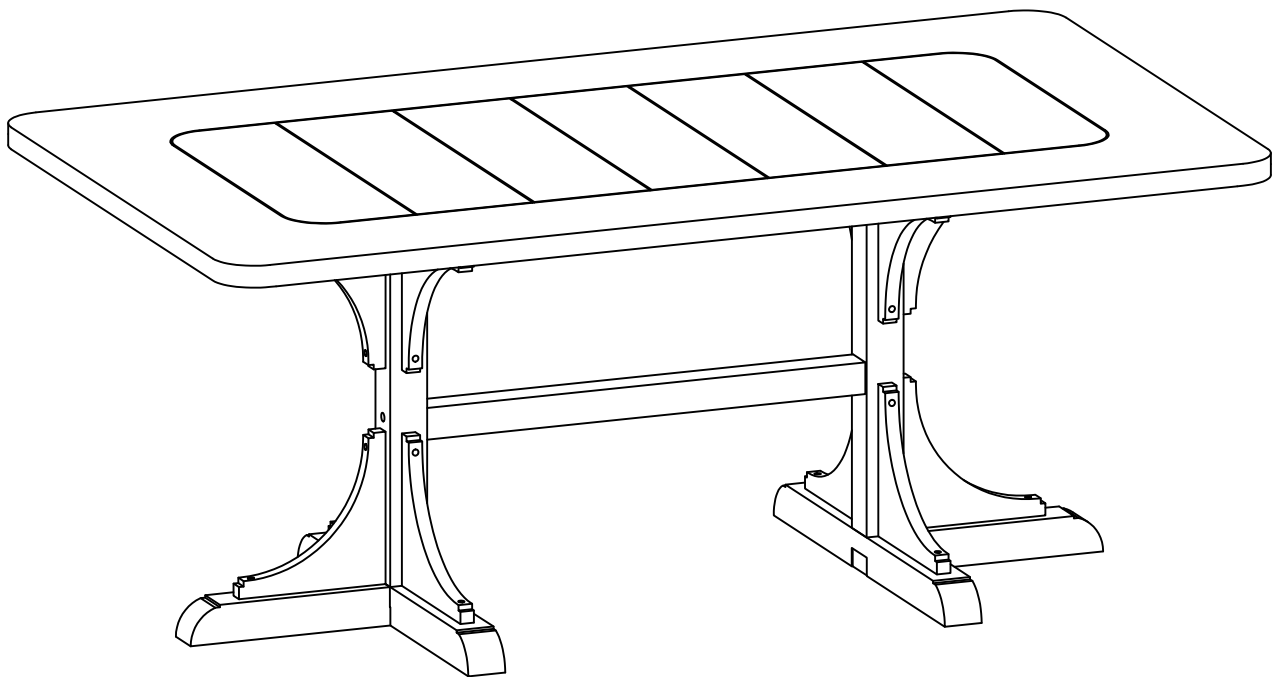





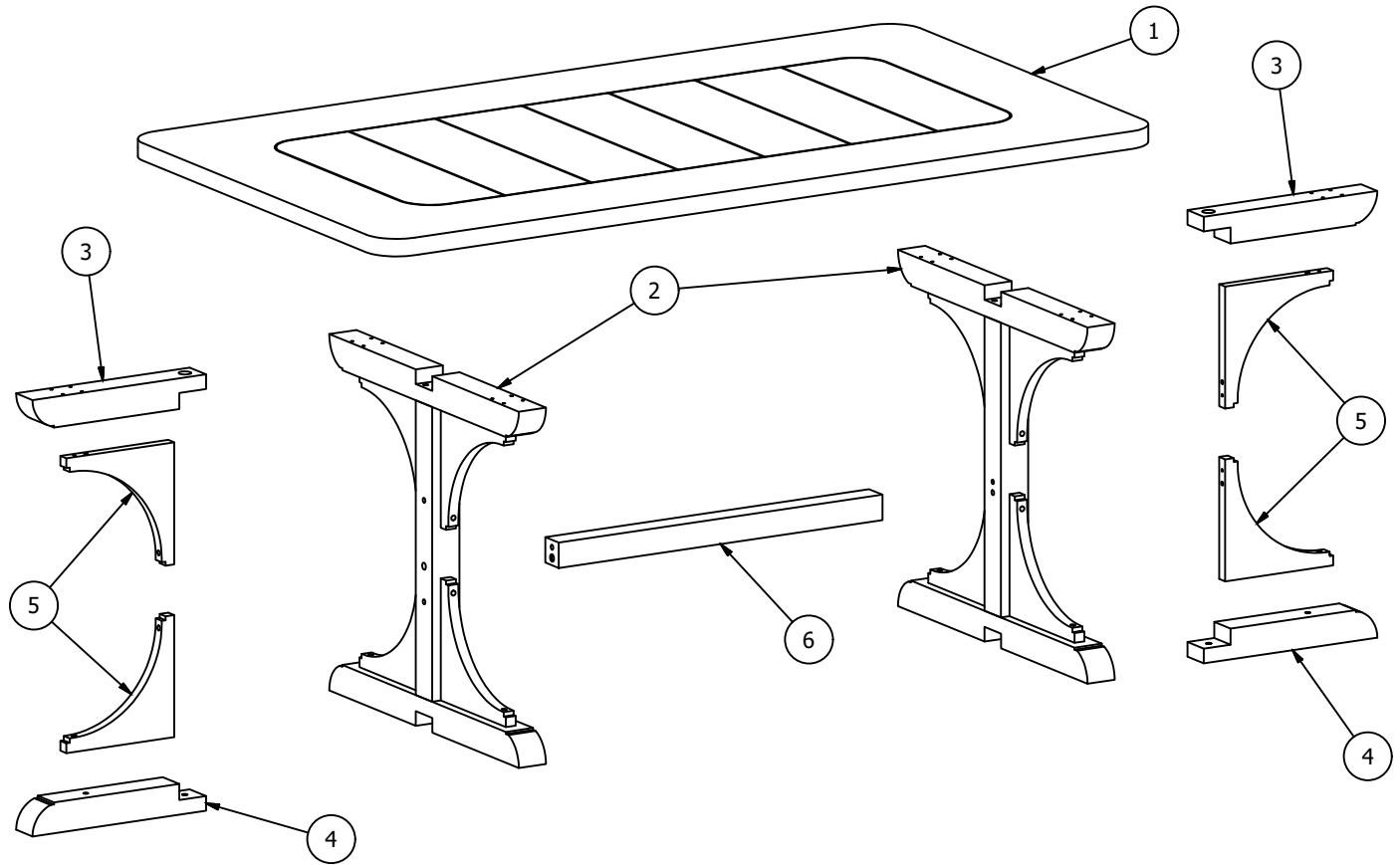

**WF306388AAE-WF306388AAD**

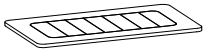











**ASSEMBLY INSTRUCTIONS**  
 Item No: WF306388AAE-WF306388AAD  
 Description: Dining Table

Thank you for purchasing this quality product. Be sure to check all packing material carefully for small part that may have come loose inside the carton during shipment.



PART LIST :			
No	DESCRIPTION	SKETCH	Qty
1	Table Top		1 pc
2	Table Leg		2 pcs
3	Table Side Leg (Top)		2 pcs
4	Table Side Leg (Bottom)		2 pcs
5	Leg Support		4 pcs
6	Center Rail		1 pc

TOOLS REQUIRED (Not provided)	
	Screwdriver

HARDWARE LIST :			
No	DESCRIPTION	SKETCH	Qty
A	ALLEN WRENCH M5		1 pc
B	JCBB SCREW M8 X 80MM		4 pcs
C	JCBC SCREW M6 X 70MM		2 pcs
D	SPRING WASHER M6 X 13MM		2 pcs
E	SPRING WASHER 5/16		4 pcs
F	FLAT WASHER 1/4x19x2MM		4 pcs
G	WOOD DOWEL M8 X 30MM		8 pcs
H	CSK SCREW M4 X 32MM		32 pcs
I	WOOD BUTTON 10MM		24 pcs
J	WOOD BUTTON 14.5MM		2 pcs
K	WOOD DOWEL M10 X 40MM		2 pcs
L	ALLEN WRENCH M4		1 pc

**ASSEMBLY INSTRUCTIONS**  
 Item No: WF306388AAE-WF306388AAD  
 Description: Dining Table

Thank you for purchasing this quality product. Be sure to check all packing material carefully for small part that may have come loose inside the carton during shipment.

**Step 1: Screw table leg and leg support with hardware H.**

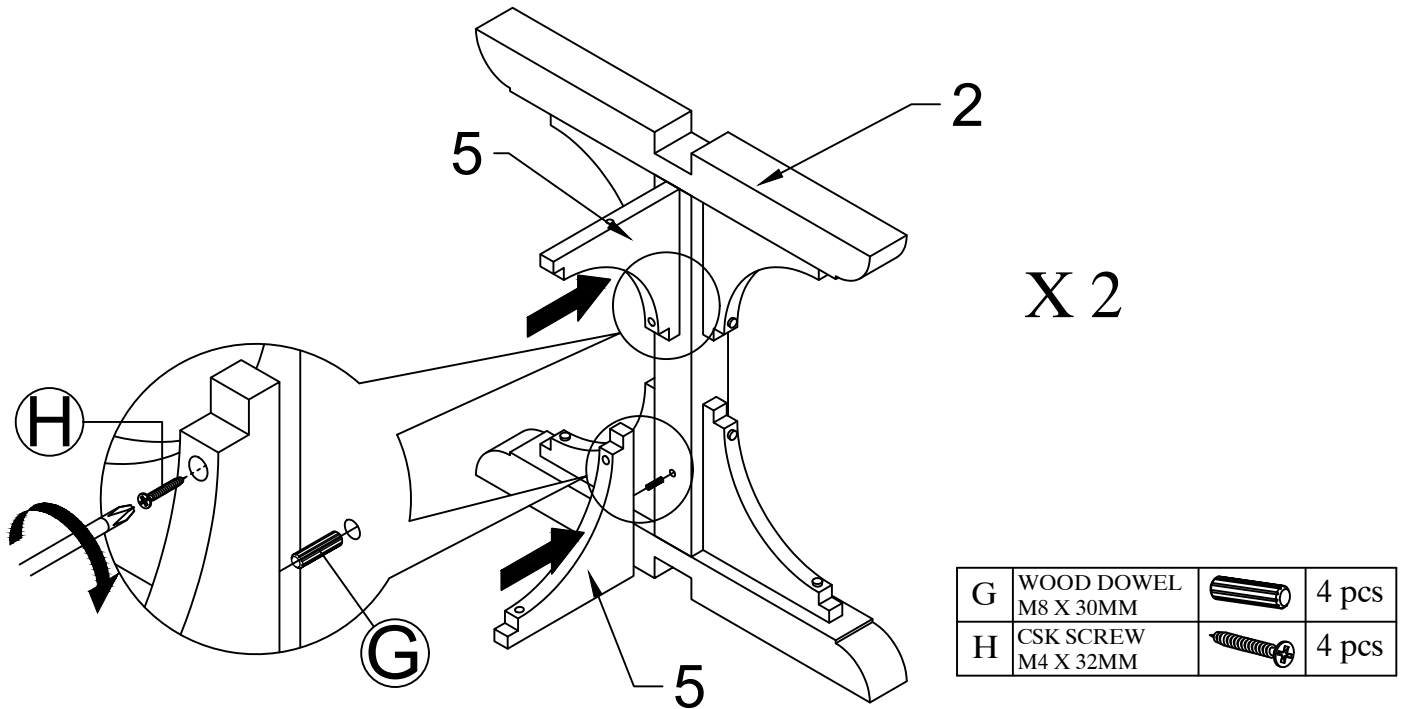

**Step 2: Screw leg support with table side leg top and table side leg btm with hardware H .**  
 Put hardware G to between table side leg top and leg support. Tie table side leg btm and table leg with hardware B, E, F

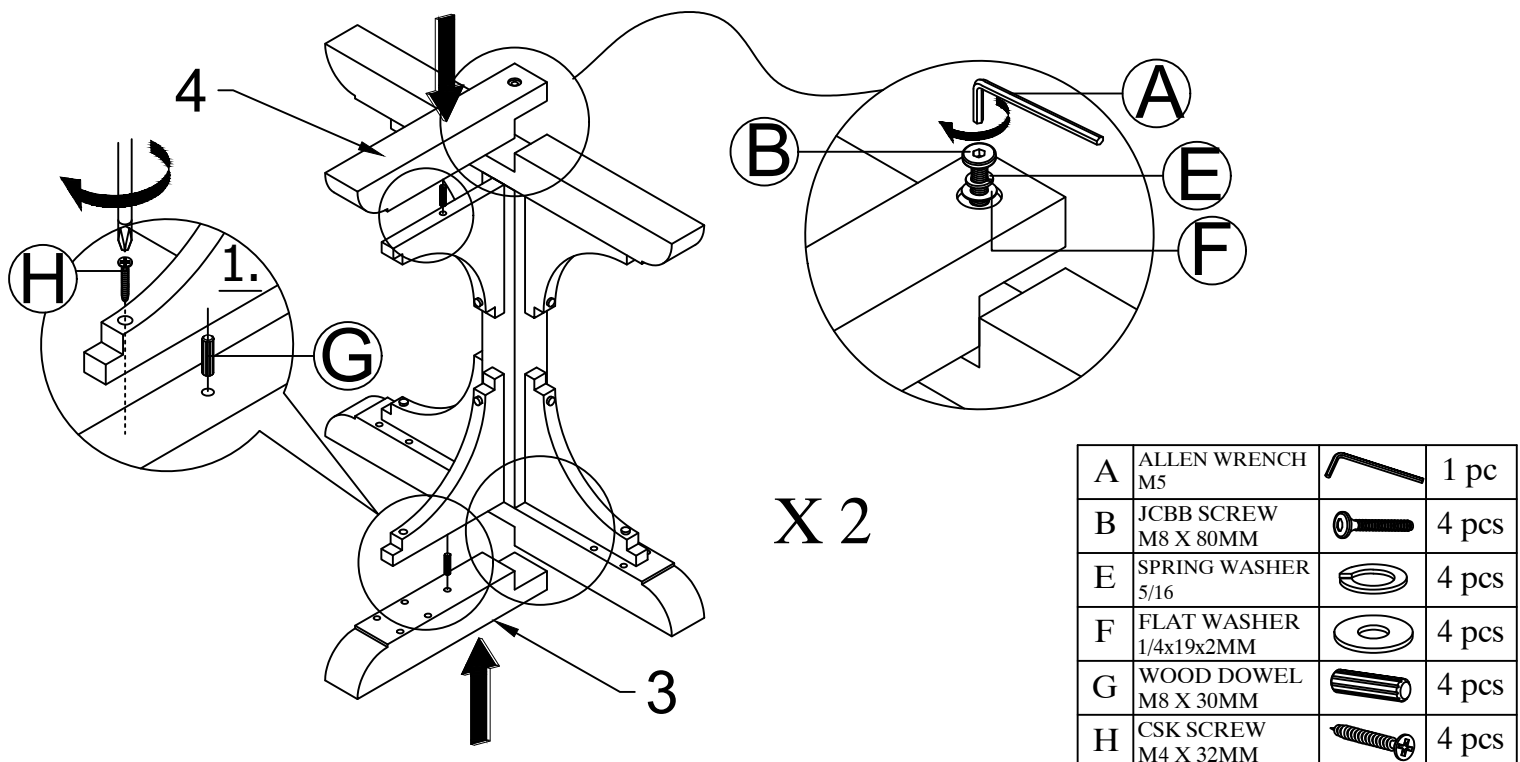

**ASSEMBLY INSTRUCTIONS**  
 Item No: WF306388AAE-WF306388AAD  
 Description: Dining Table

Thank you for purchasing this quality product. Be sure to check all packing material carefully for small part that may have come loose inside the carton during shipment.

**Step 3: cover the hole with hardware I.**

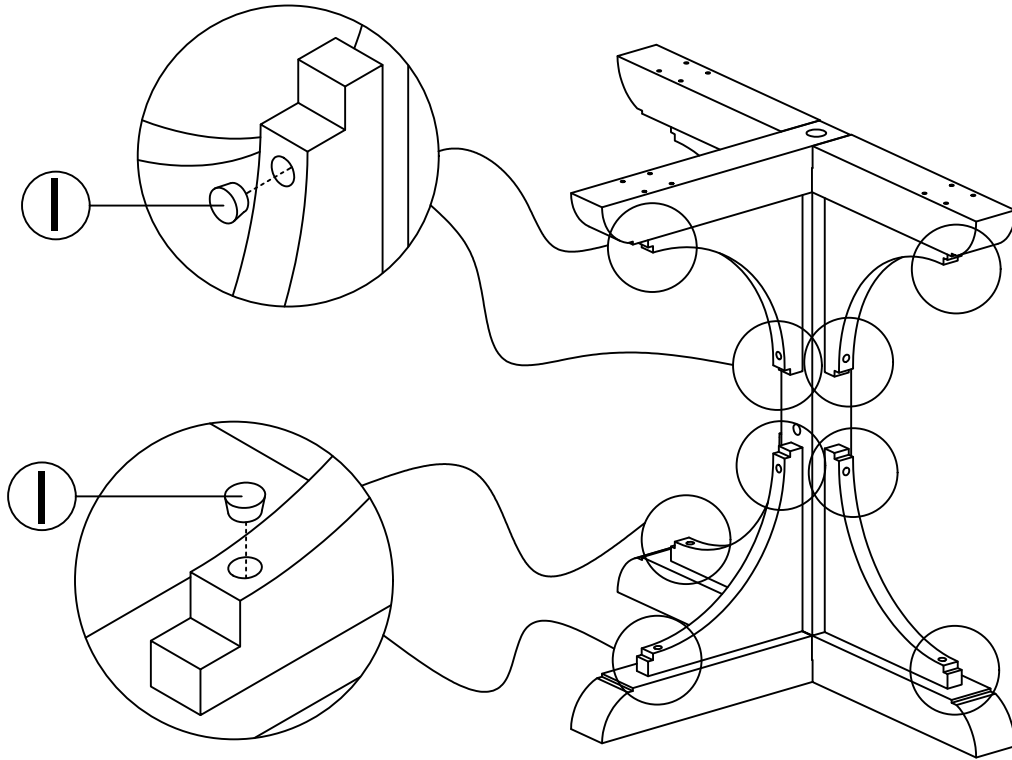



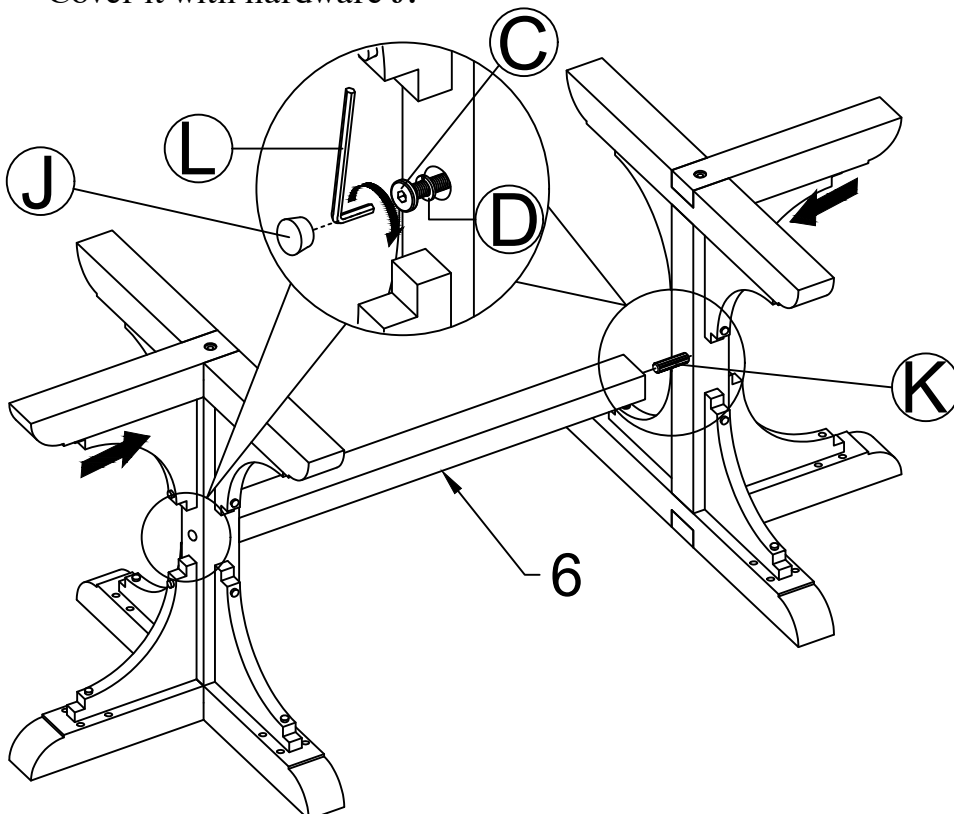

**X 2**

<b>I</b>	WOOD BUTTON 10MM		24 pcs
----------	---------------------	---	--------

**Step 4: Put hardware K to between center rail and table leg. And then tie it with hardware C, D.  
 Cover it with hardware J.**





<b>C</b>	JCBC SCREW M6 X 70MM		2 pcs
<b>D</b>	SPRING WASHER M6 X 13MM		2 pcs
<b>K</b>	WOOD DOWEL M10 X 40MM		2 pcs
<b>J</b>	WOOD BUTTON 14.5MM		2 pcs
<b>L</b>	ALLEN WRENCH M4		1 pc

ASSEMBLY INSTRUCTIONS  
Item No: WF306388AAE-WF306388AAD  
Description: Dining Table

Thank you for purchasing this quality product. Be sure to check all packing material carefully for small part that may have come loose inside the carton during shipment.

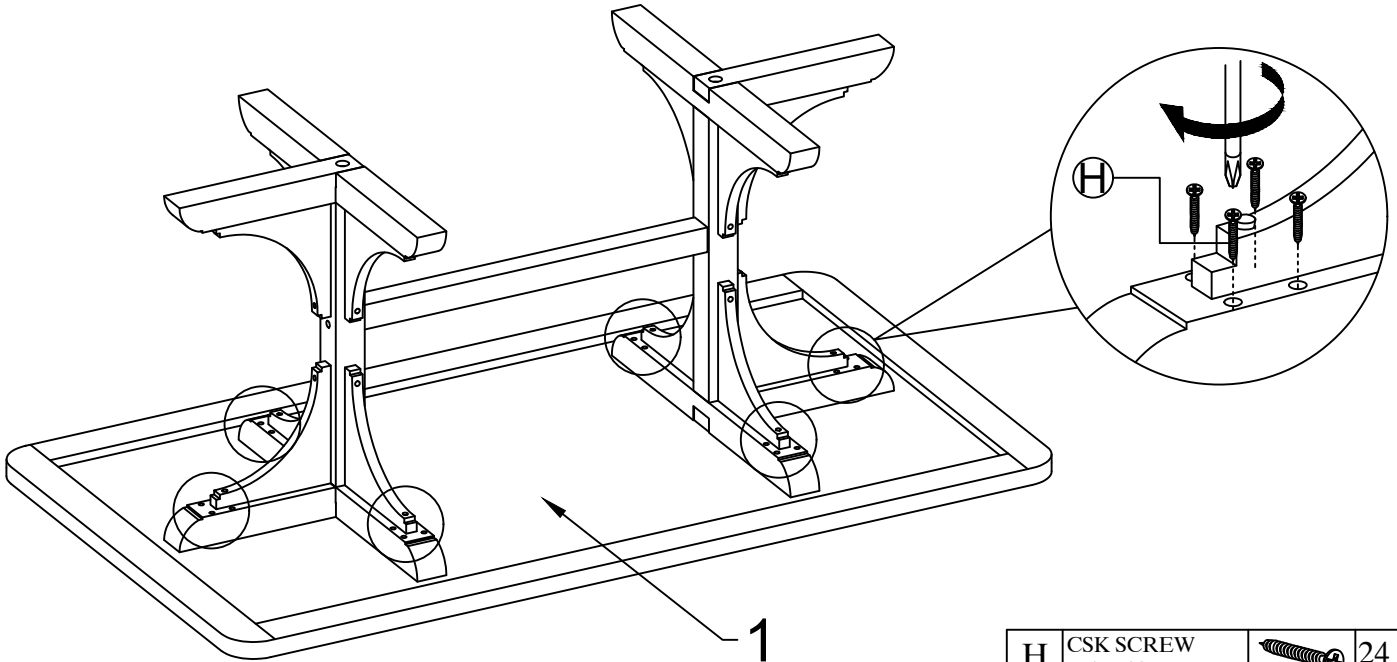
Step 4: Screw table leg with table top by using hardware H



H	CSK SCREW M4 X 32MM		24 pcs
---	------------------------	---	--------