

Outdoor Metal Bar Stool

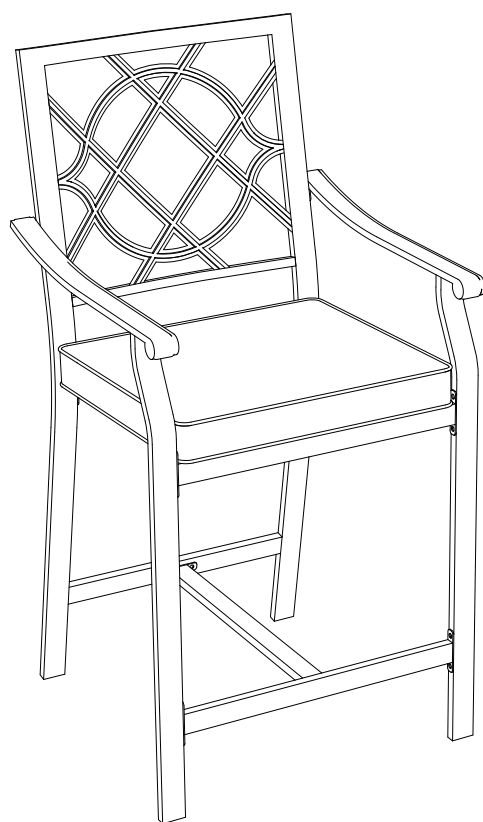

Read the instructions before use of this product.

Please keep this instruction manual for future reference.

! NOTICE

- Please keep children away during assembly. This item contains small parts that can be dangerous for children. Children should always be under direct adult supervision while using this product.
- Do not discard any of the packaging until you have checked that you have all of the parts and fittings required.
- Carefully remove the contents from the package. If any parts are missing, broken, damaged, do not attempt to use the product until they have been obtained.
- Make sure that each bolt needed for all steps matches the corresponding figure ensure proper assembly.
- Please do not exceed the weight limitations of this item.
- Do not stand on or use any part of this item as a step ladder.
- Firmly secure all bolts, screws and knobs before use.
- Be aware that some parts are heavy and have sharp edges.
- Do not use or store this item in the proximity of open flame or flammable/combustible chemicals.

CLEANING AND MAINTENANCE

- Clean frame with mild soapy water, rinse thoroughly. Dry frame parts completely. Do not use bleach, acid, or other solvents on the fabric and metal parts.
- If outdoor furniture is caught during a sudden rain storm, please make sure to drain any water that may have accumulated inside the frame and dry completely.
- We recommend the use of furniture covers to protect when not in use, and store properly during inclement weather and the winter/rainy seasons.
- Inspect and tighten all bolts on a regular basis to ensure proper performance and safety.
- In order to prolong the life and beauty of your outdoor furniture, we recommend storing it in a dry and protective area during off season periods.

PARTS

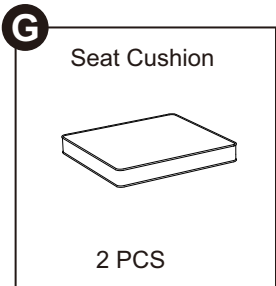
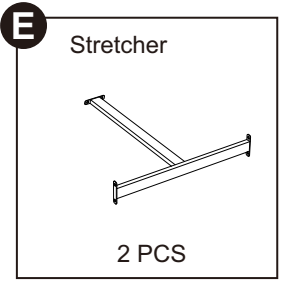
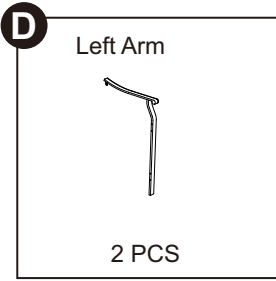
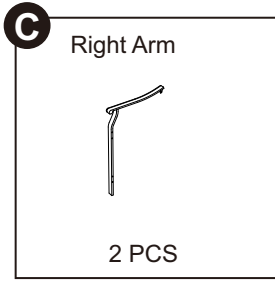
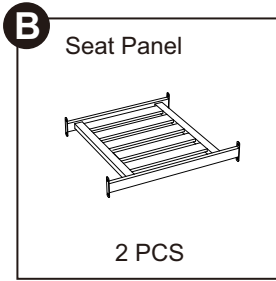
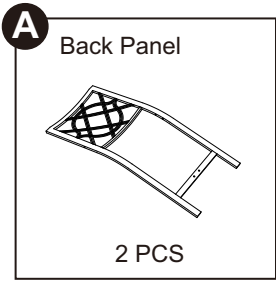

HARDWARE

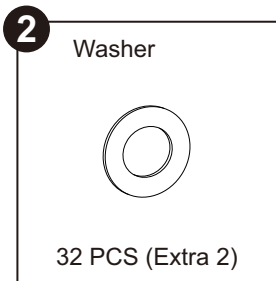
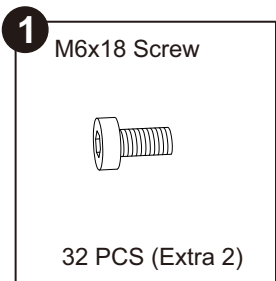

TOOLS REQUIRED

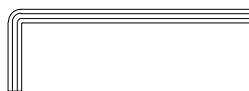

Allen Wrench
1PC

PRODUCT ASSEMBLY

1

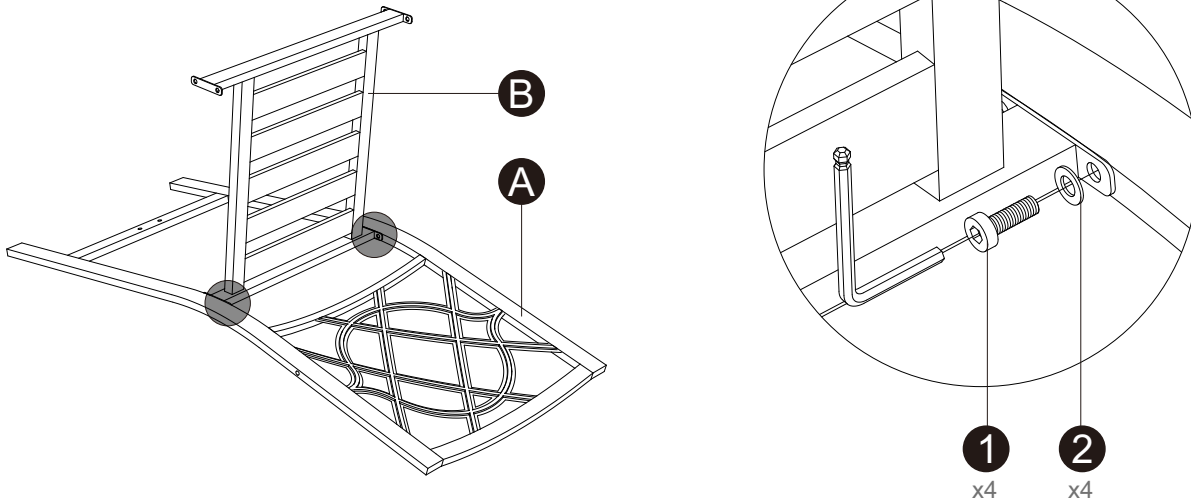

Attach seat panel (B) to back panel (A) using screws (1), washers (2) and allen wrench.

NOTE: Please do not fully tighten bolts until unit is fully assembled.

2

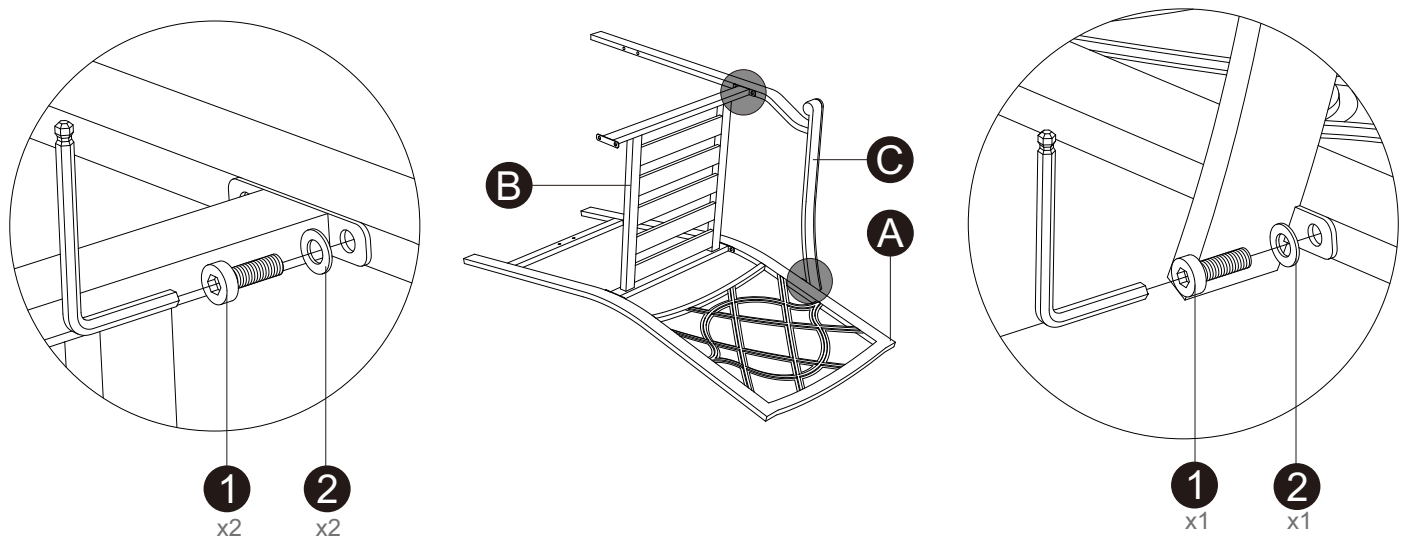

Attach right arm (C) to seat panel (B) and back panel (A) using screws (1), washers (2) and allen wrench.

NOTE: Please do not fully tighten bolts until unit is fully assembled.

PRODUCT ASSEMBLY

3

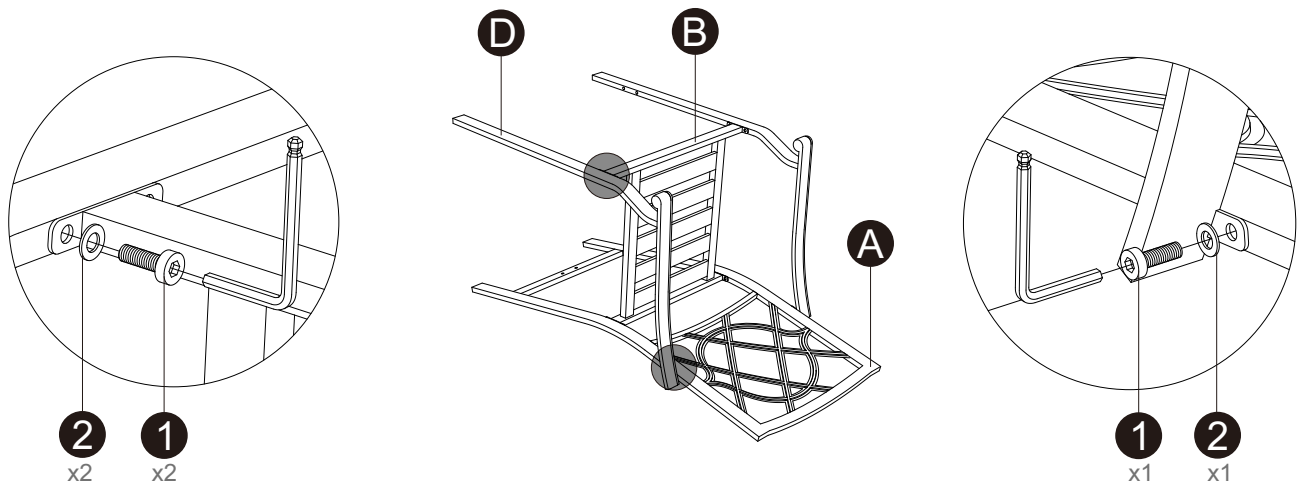

Attach left arm (D) to seat panel (B) and back panel (A) using screws (1), washers (2) and allen wrench.

NOTE: Please do not fully tighten bolts until unit is fully assembled.

4

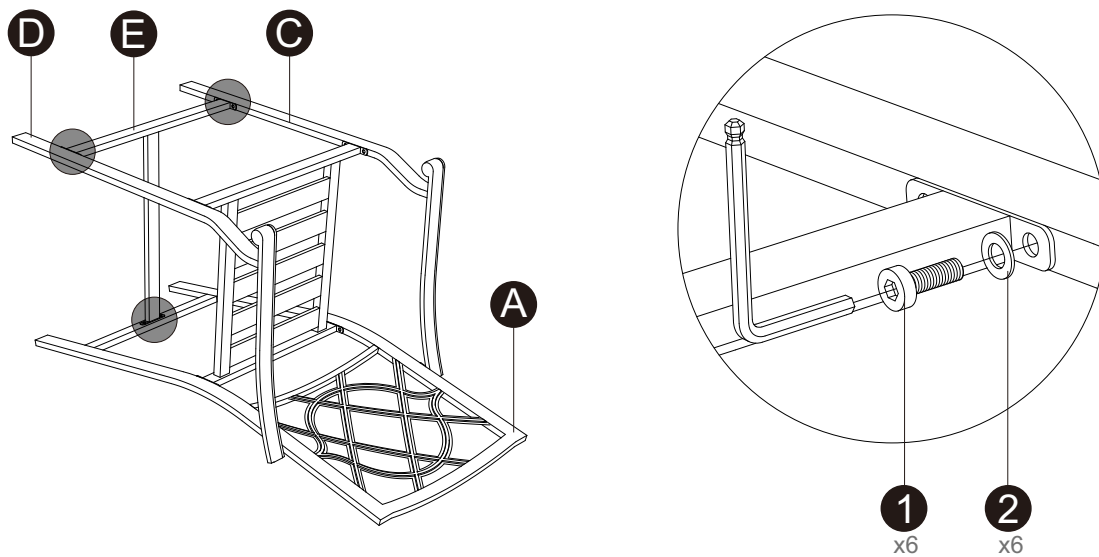

Attach stretcher (E) to arms (C & D) and back panel (A) using screws (1), washers (2) and allen wrench.

NOTE: Please fully tighten all bolts at this time.

5

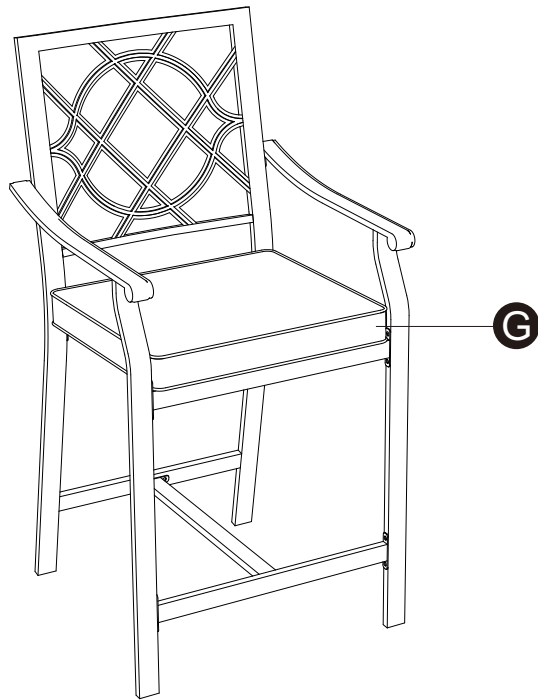

Carefully turn unit upright.

Place seat cushion(G). Repeat steps 1-5 to assemble remaining stool.