

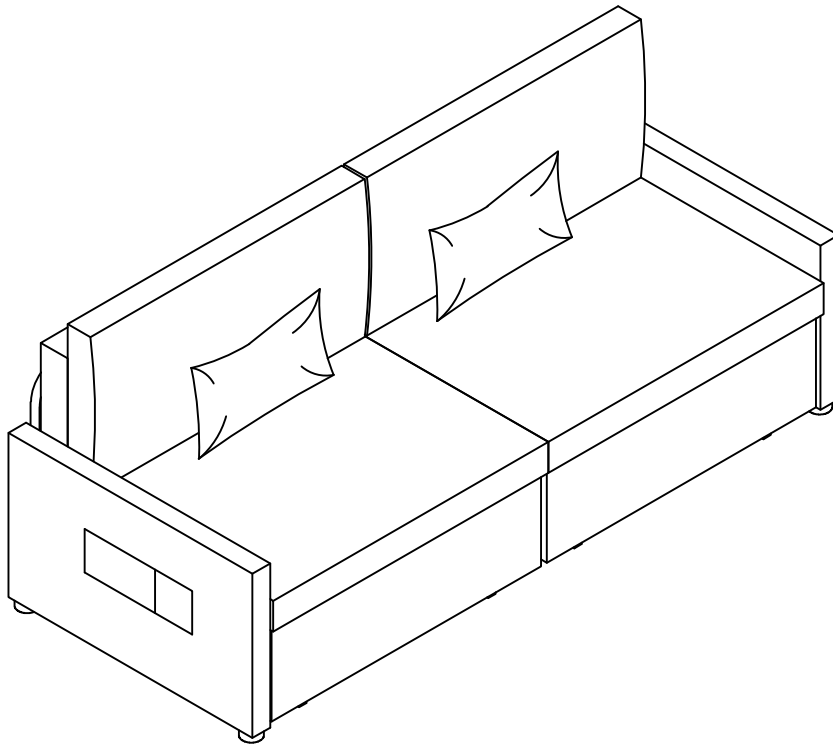

X 2

# Owner Manual Sofa Bed



## FAQ

Q1: What should I do if the product I received is damaged or incorrect?

A1: If you've received a damaged, incorrect, or incomplete product, please reach out to our Customer Support Center . Include your order number and photos.

Q2: What should I do if I encounter problems during installation?

A2: If you encounter any installation issues, please attach a detailed description of the problem, we will provide you for professional technical support.

Q3: How do I apply a return?

A3: You can initiate a return within 30 days of purchase. Email us with your order number and the reason for return. We'll guide you through the process.

Note:

- Please contact us before returning the product to avoid any complications.
- Ensure the product is returned in its original packaging with all accessories included.

## PREGUNTAS FRECUENTES

P1: ¿Qué debo hacer si el producto que he recibido está dañado o es incorrecto?

R1: Si has recibido un producto dañado, incorrecto o incompleto, ponte en contacto con nuestro Centro de Atención al Cliente. Incluye tu número de pedido y fotos que documenten el problema para que podamos ayudarte con la devolución o el cambio.

P2: ¿Qué debo hacer si encuentro problemas durante la instalación?

R2: Si tienes algún problema durante la instalación, por favor envía un correo electrónico adjuntando una descripción detallada del problema.

Te proporcionaremos soporte técnico profesional.

P3: ¿Cómo puedo solicitar una devolución?

R3: Puede iniciar una devolución en los 30 días siguientes a la compra. Envíenos un correo electrónico con su número de pedido y el motivo de la devolución. Te guiaremos a través del proceso.

Nota:

- Póngase en contacto con nosotros antes de devolver el producto para evitar complicaciones.
- Asegúrate de devolver el producto en su embalaje original y con todos los accesorios incluidos.

# Product Guide and Maintenance Instructions

EN

Thank you for purchasing our product! To ensure a smooth installation and optimal user experience, we recommend that you carefully read the following guide and instructions before starting.

## Assembly Instructions:

- Before installation, inspect all parts and accessories to confirm that none are damaged or missing. If any issues are found, please contact us promptly.
- Assemble the product in a spacious and flat area to ensure sufficient space for moving parts, avoid accidental collisions, and facilitate the assembly process.
- It is advisable to refer to the schematic diagrams during assembly to make the process easier. Align all screws with the corresponding pre-drilled holes, then tighten each screw one by one after all parts are correctly positioned.
- When tightening screws during assembly, pay attention to the force applied. If any parts are damaged, please contact us promptly.

## Safety Warnings:

- **Child Safety**  
Keep small parts out of reach of children during assembly. Do not allow children to climb on or play with the product to prevent serious injuries from tipping.

## Usage Restrictions:

- Do not stand on or jump on the sofa.
- Avoid placing sharp objects on the sofa to prevent material damage.

## Product Usage:

- This product is intended for indoor use only. We are not responsible for any damage caused by unintended use or modifications.

## Product Maintenance:

- **Environmental Conditions**  
Keep the product away from direct sunlight, rain, and damp areas to prevent fading or deformation. Also, keep it away from sharp objects and corrosive substances to protect the sofa's surface.

By following these guidelines, you can enjoy a safe and pleasant product experience. Thank you for choosing our product!

ES

¡Gracias por adquirir nuestro producto! Para garantizar una instalación sencilla y una experiencia de uso óptima, le recomendamos leer atentamente la siguiente guía e instrucciones antes de comenzar.

## Instrucciones de Montaje

- Antes de la instalación, inspeccione todas las piezas y accesorios para asegurarse de que no estén dañados ni falten. Si encuentra algún problema, contáctenos de inmediato.
- Ensamble el producto en un área espaciosa y plana para garantizar suficiente espacio para las piezas móviles, evitar colisiones accidentales y facilitar el proceso de montaje.
- Se recomienda consultar los diagramas esquemáticos durante el montaje para facilitar el proceso. Alinee todos los tornillos con los orificios preperforados correspondientes y, una vez que todas las piezas estén correctamente posicionadas, apriete cada tornillo uno por uno.
- Al apretar los tornillos durante el montaje, preste atención a la fuerza aplicada. Si alguna pieza está dañada, contáctenos de inmediato.

## Advertencias de Seguridad

- **Seguridad Infantil**  
Mantenga las piezas pequeñas fuera del alcance de los niños durante el montaje. No permita que los niños trepen o jueguen con el producto para evitar posibles lesiones graves por vuelco.

## Restricciones de Uso

- No se pare ni salte sobre el sofá.
- Evite colocar objetos afilados sobre el sofá para prevenir daños en el material.

## Uso del Producto

- Este producto está diseñado exclusivamente para uso en interiores. No nos hacemos responsables de los daños causados por un uso inadecuado o modificaciones.

## Mantenimiento del Producto

- **Condiciones Ambientales**  
Mantenga el producto alejado de la luz solar directa, la lluvia y las áreas húmedas para evitar la decoloración o deformación. Asimismo, protéjalo de objetos afilados y sustancias corrosivas para preservar la superficie del sofá.

Siguiendo estas recomendaciones, podrá disfrutar de una experiencia segura y satisfactoria con nuestro producto.

¡Gracias por elegir nuestro producto!

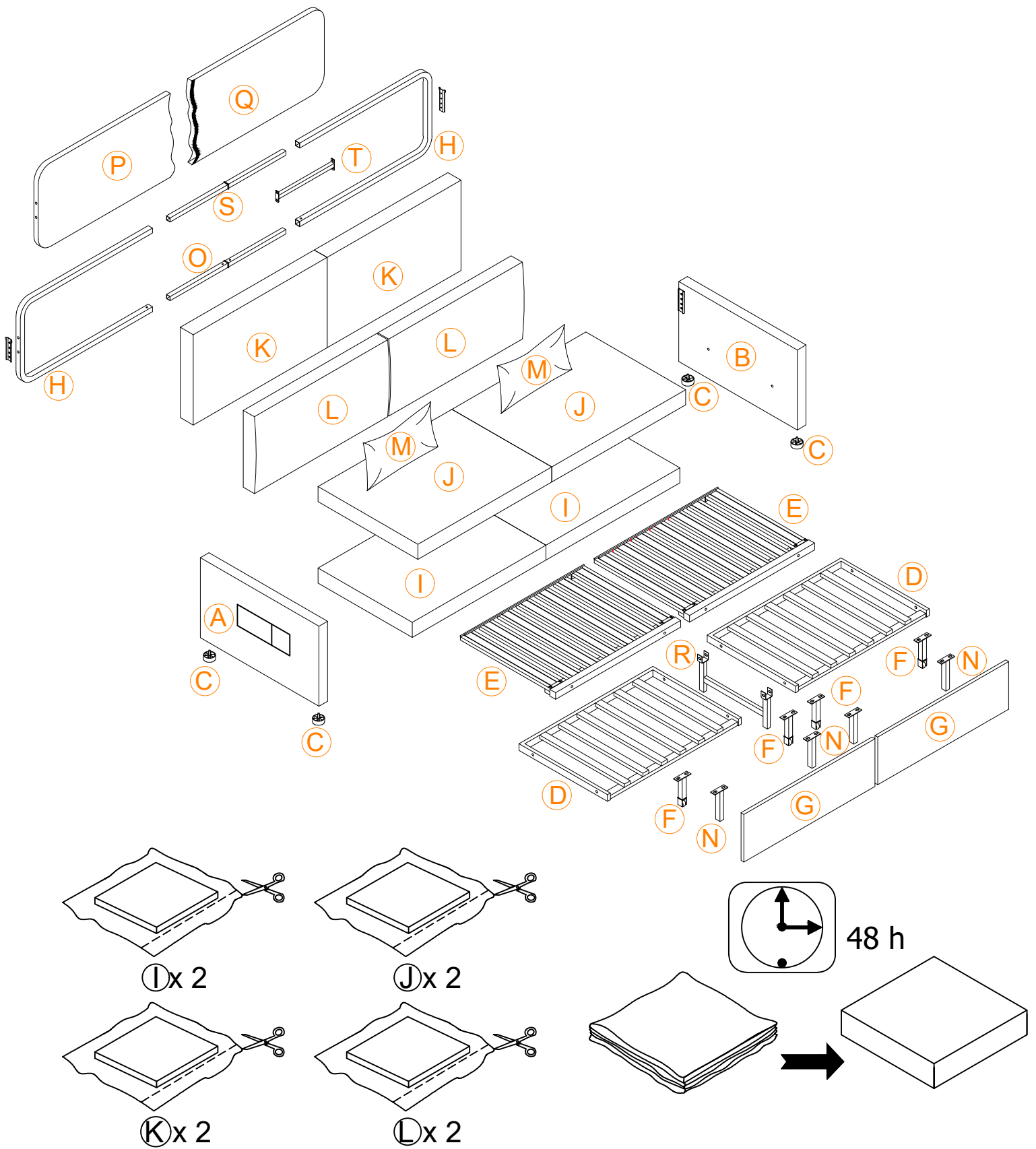

**Please don't tighten the screws until all the screws are put into the hole. And if there is any problem, please contact us and we will help you to solve it.**

# BOX 1

A x 1

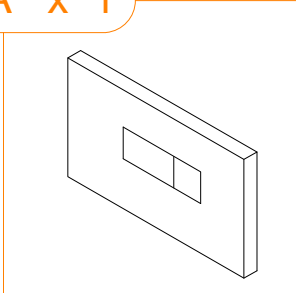

C x 2

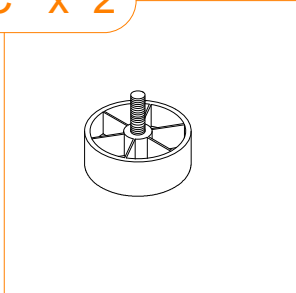

D x 1

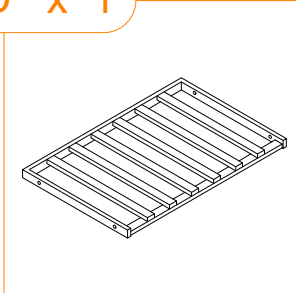

E x 1

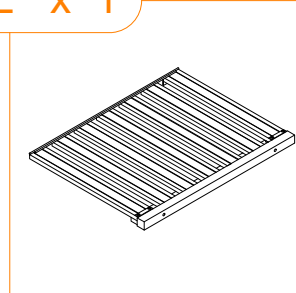

F x 2

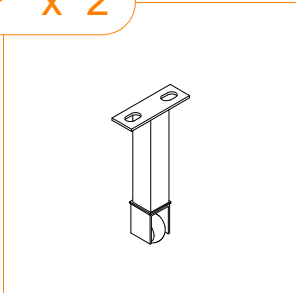

G x 1

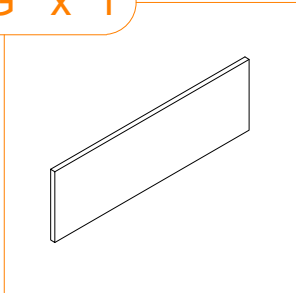

H x 1

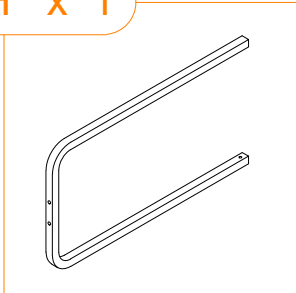

I x 1

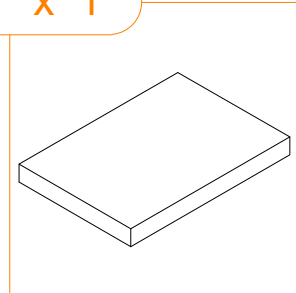

J x 1

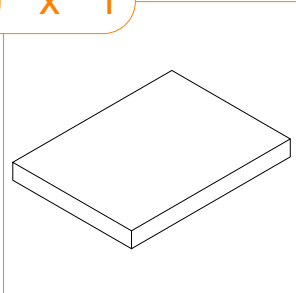

K x 1

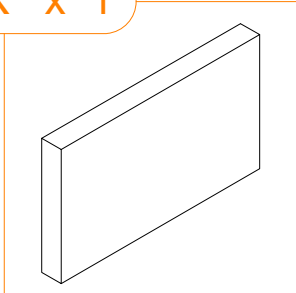

L x 1

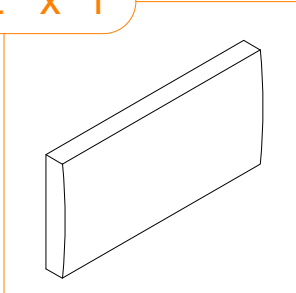

M x 1

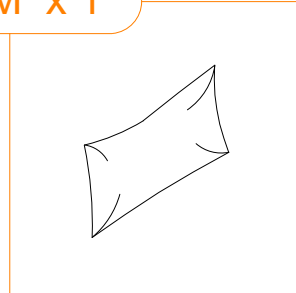

N x 2

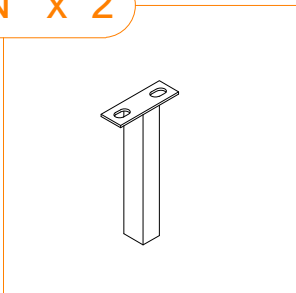

O x 1

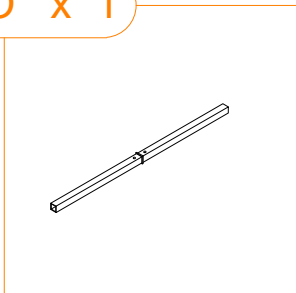

P x 1

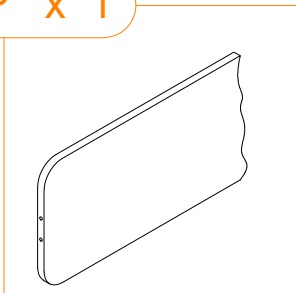

R x 1

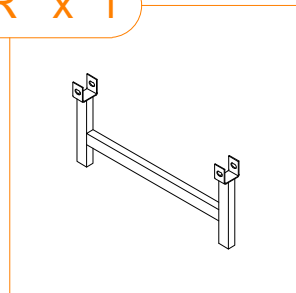

x 1

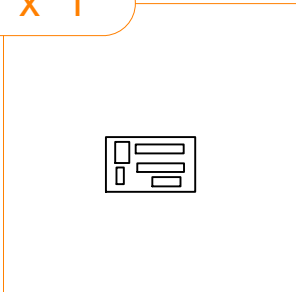

# BOX 2

B x 1

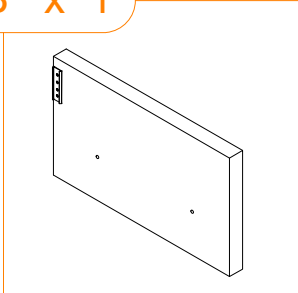

C x 2

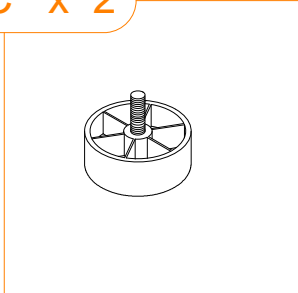

D x 1

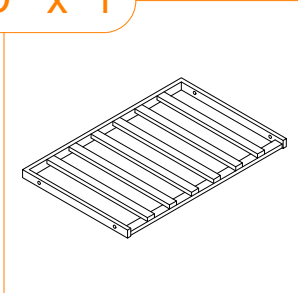

E x 1

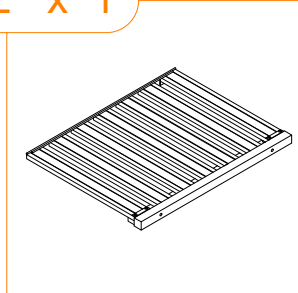

F x 2

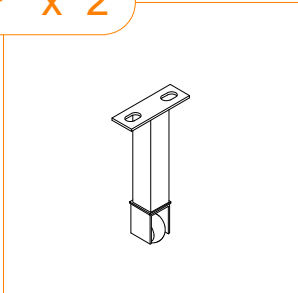

G x 1

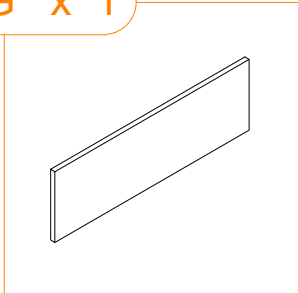

H x 1

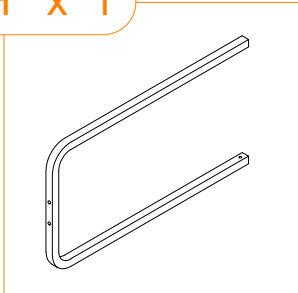

I x 1

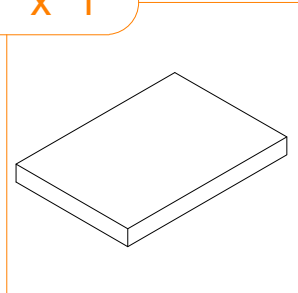

J x 1

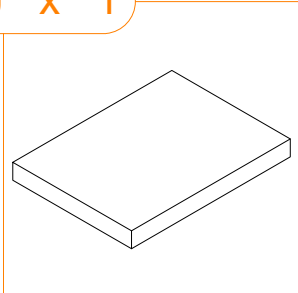

K x 1

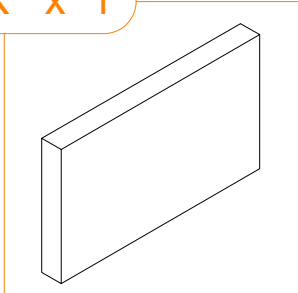

L x 1

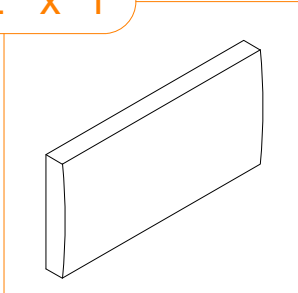

M x 1

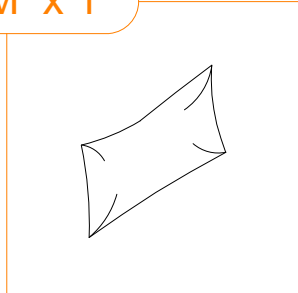

N x 2

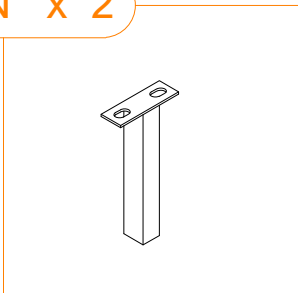

S x 1

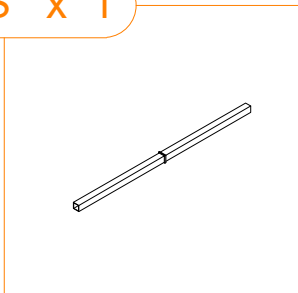

Q x 1

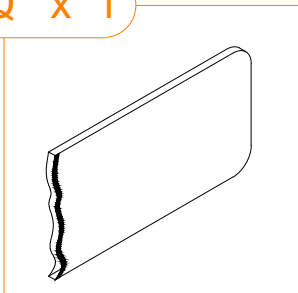

T x 1

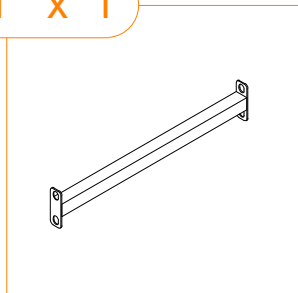

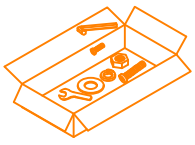

1 x 1



M8

2 x 28



M8

3 x 28



M8x19mm

4 x 16



M8x19mm

5 x 10

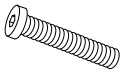

M8x55mm

6 x 1



M6

7 x 4



M6

8 x 4



M6x16mm

9 x 8



M6x25mm

10 x 2

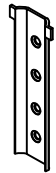

120x40x10

11 x 2



12 x 1

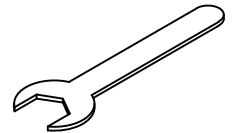

13mm

1

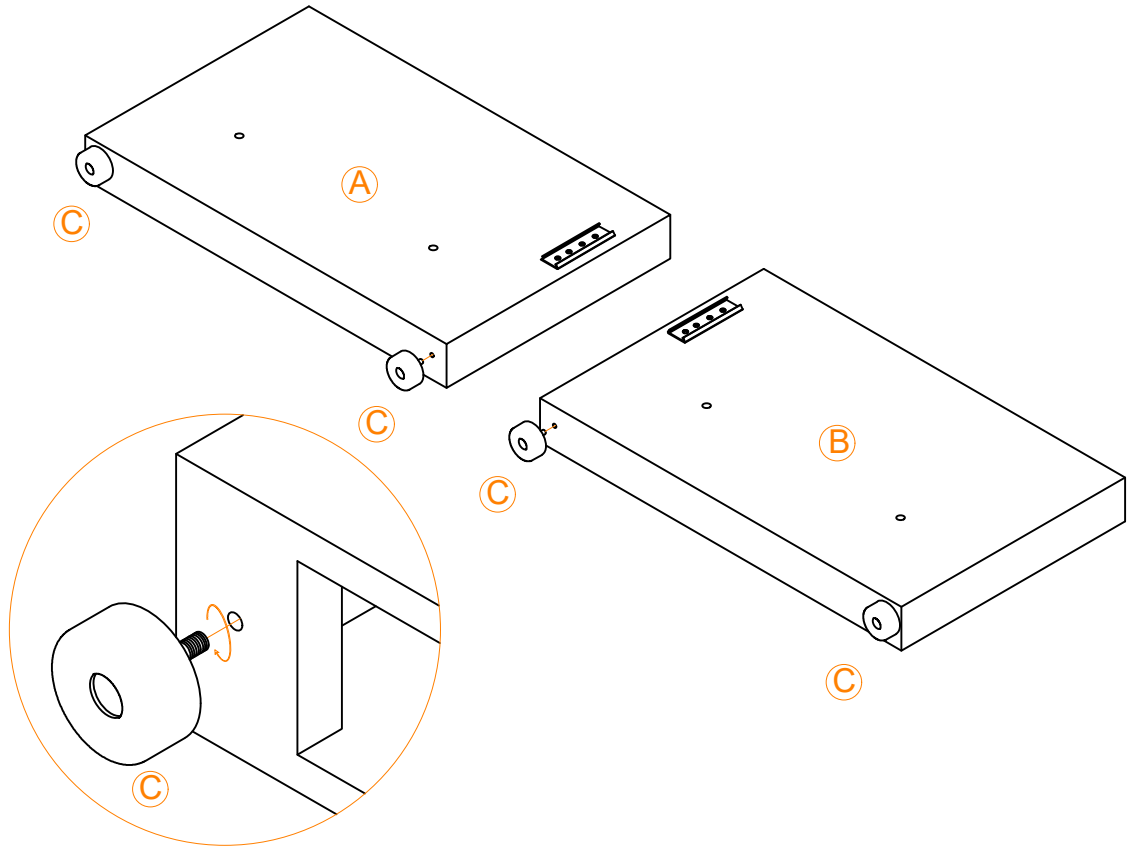
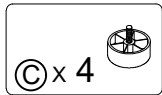
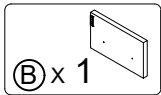
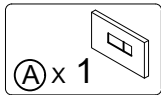

2

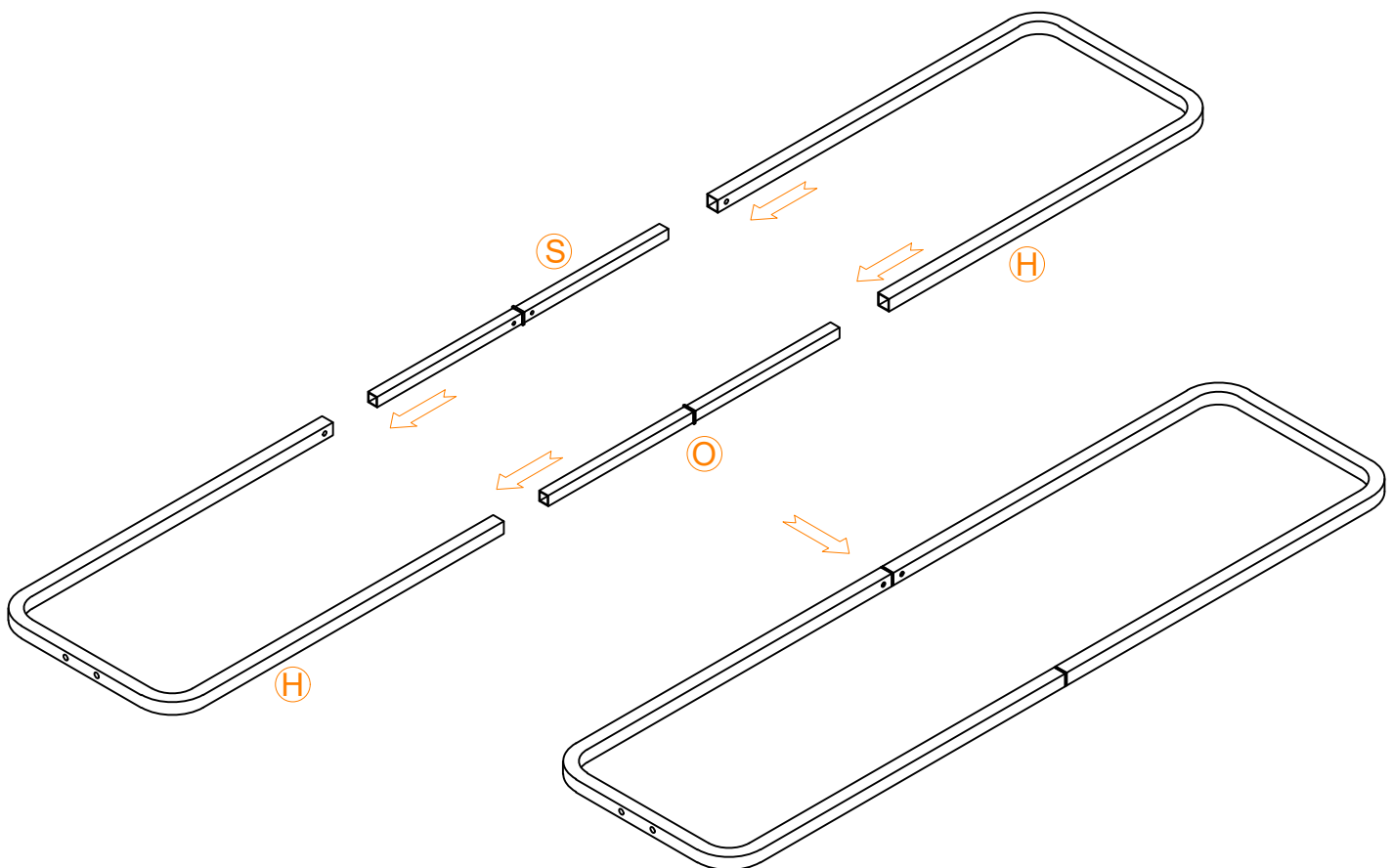
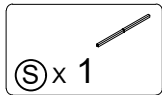
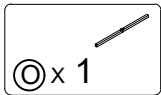
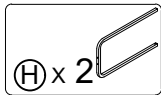

3

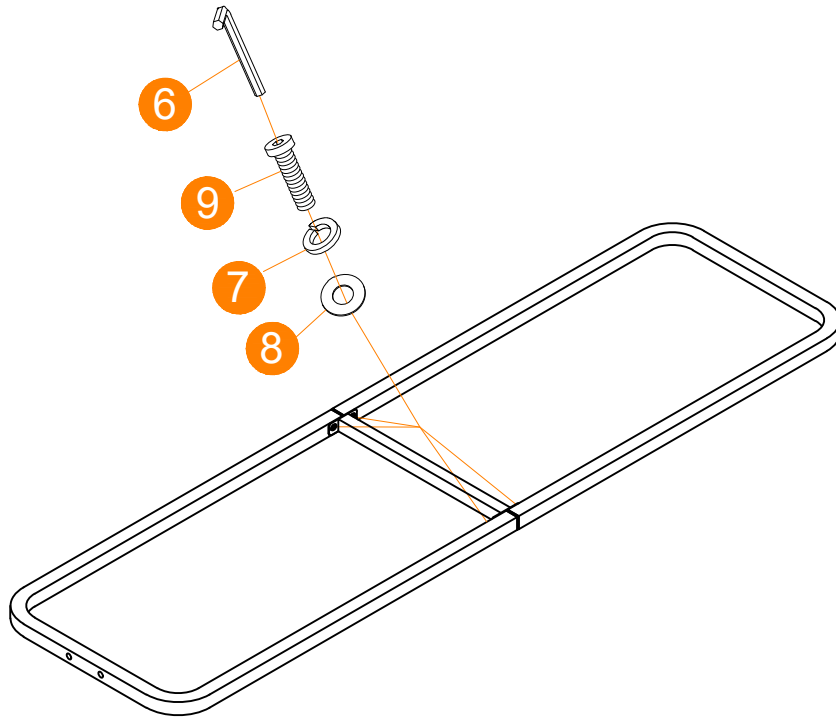
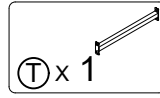
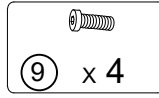
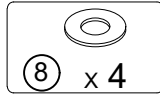
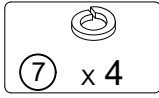
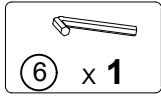

4

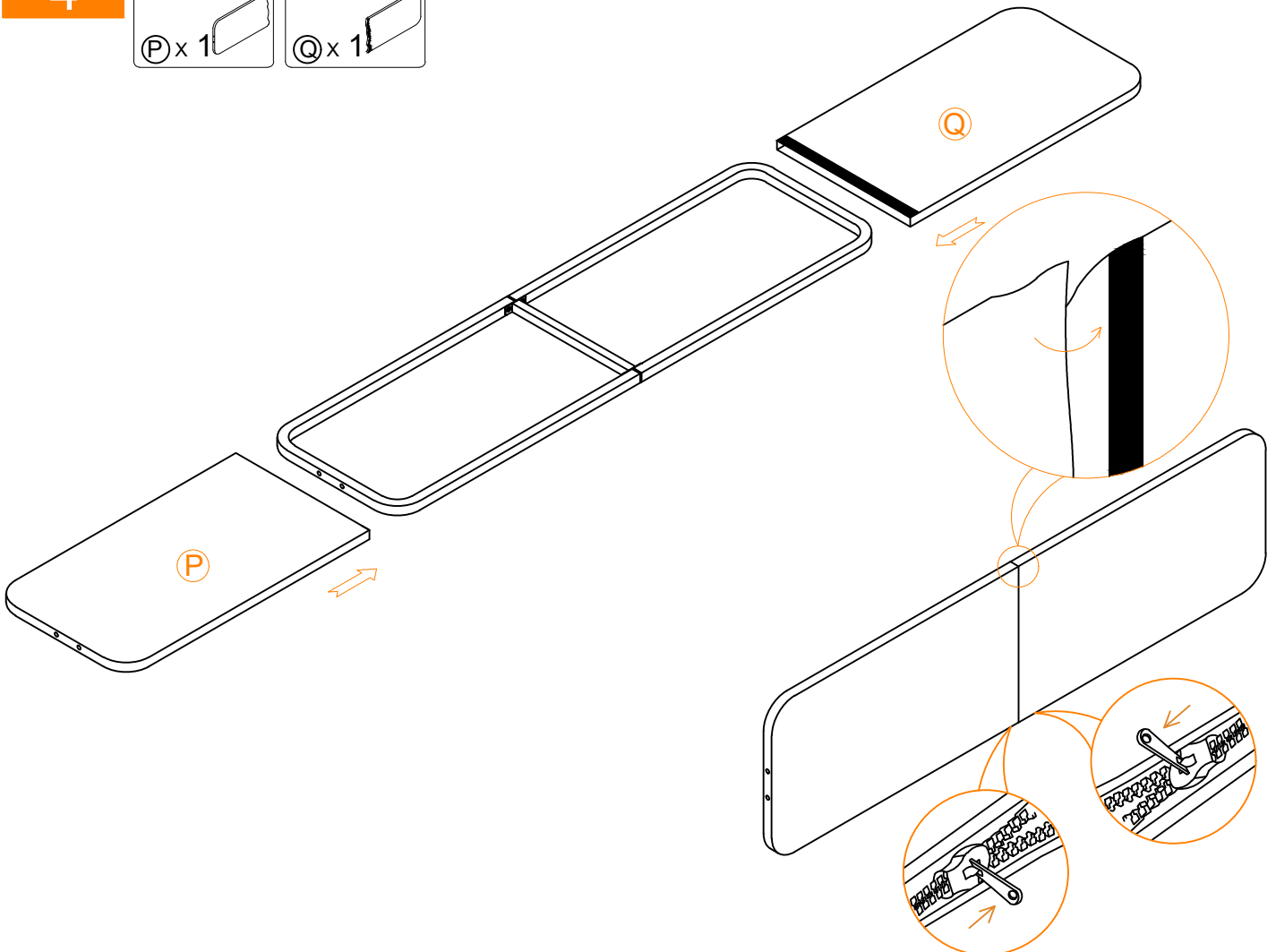
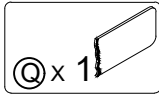
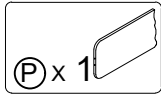

5

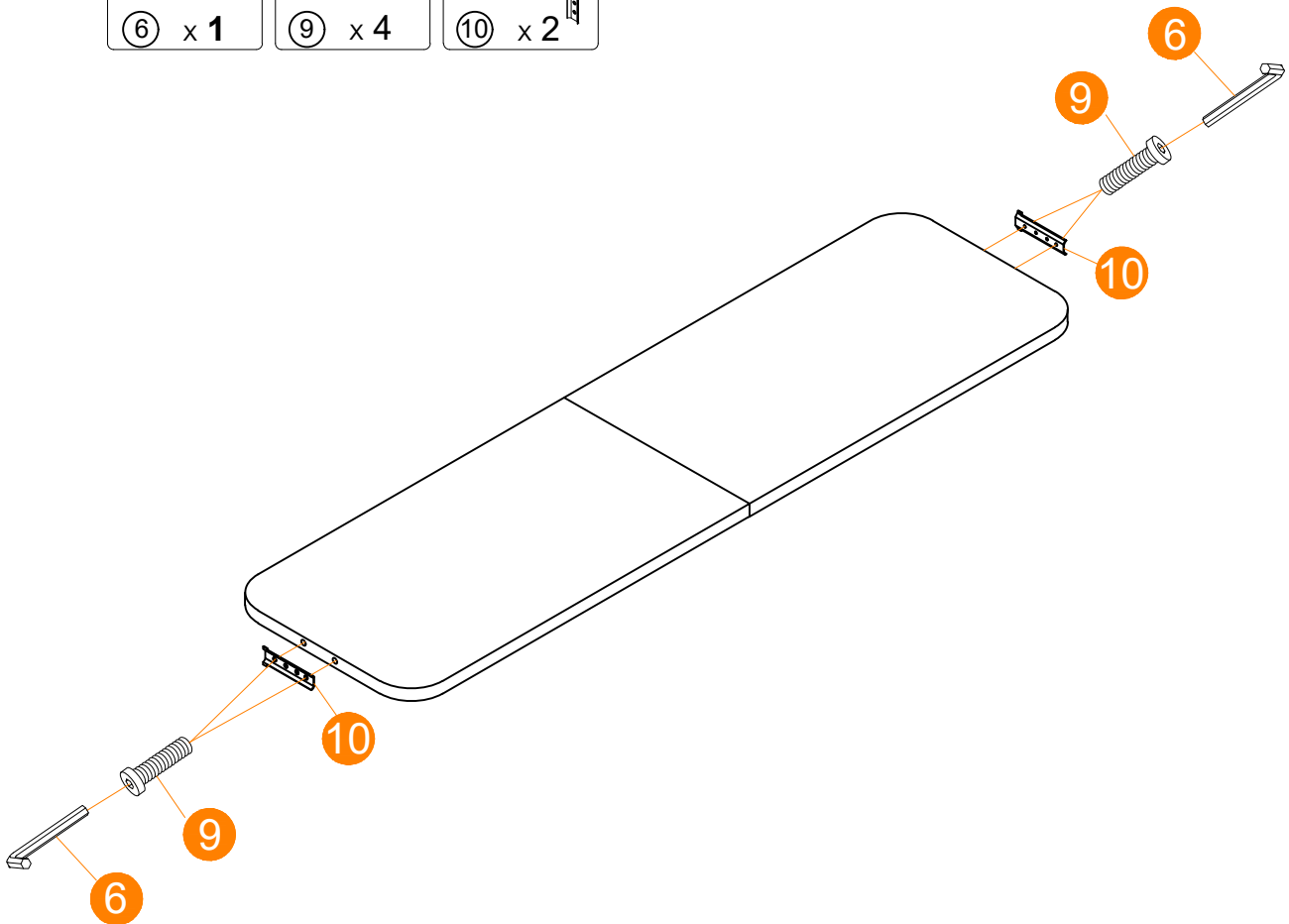
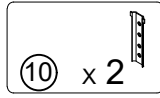
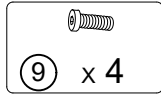
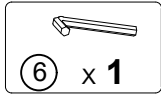

6

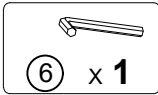
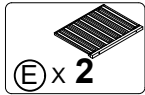

- EN: Loosen pre-installed screws but do not remove.  
 DE: Vorgebaute Schrauben lösen, aber nicht entfernen.  
 IT: Allentare le viti preinstallate ma non rimuoverle.  
 FR: Desser les vis préinstallées mais ne pas les retirer.  
 ES: Afloje los tornillos preinstalados pero no los retire.

If the metal part slides tightly, slightly loosen the screw during assembly. After finishing, tighten it until movement is smooth

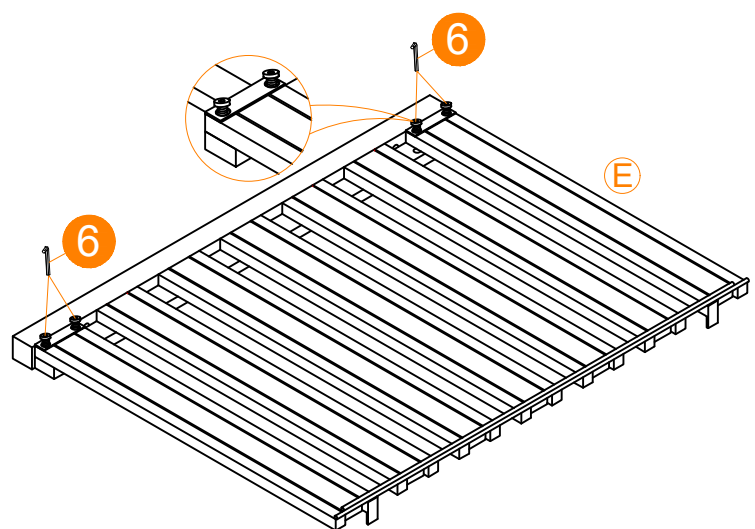
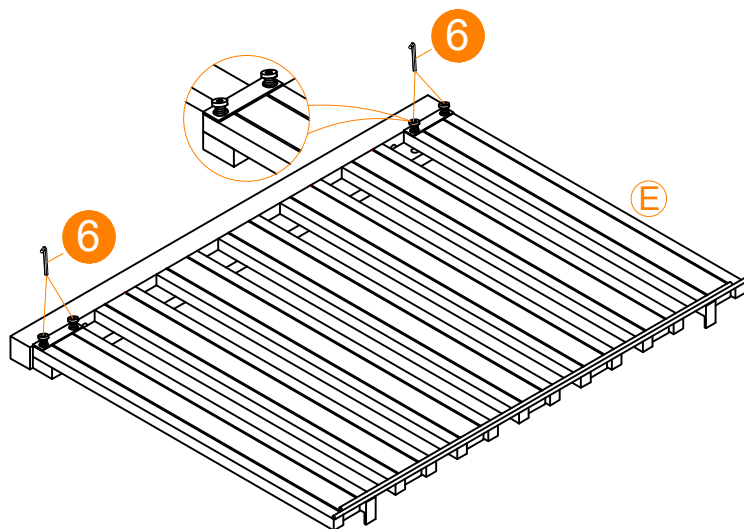

ⓔ x 2

7

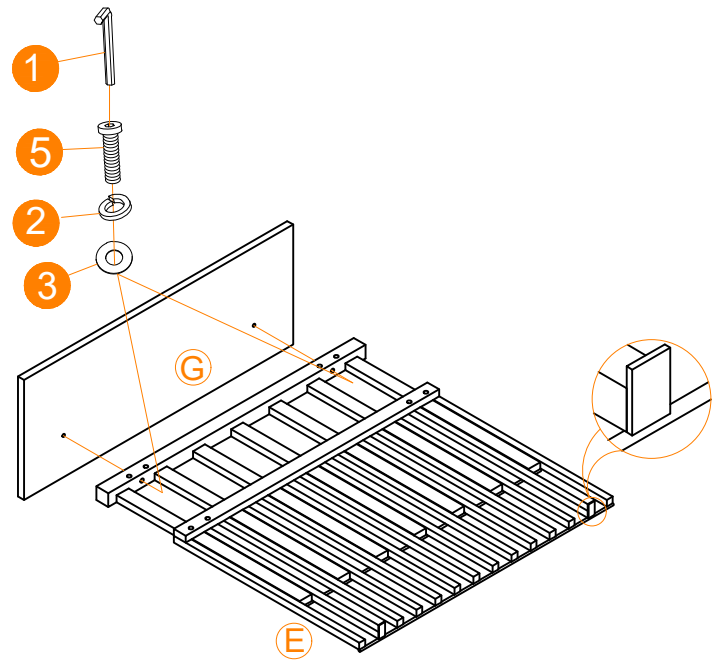
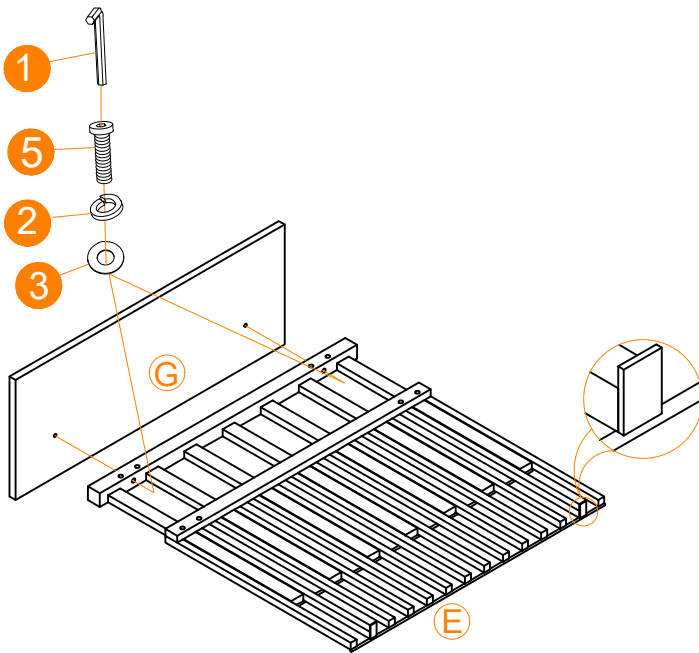
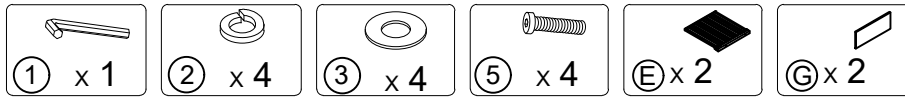

E x 2  
G x 2

8

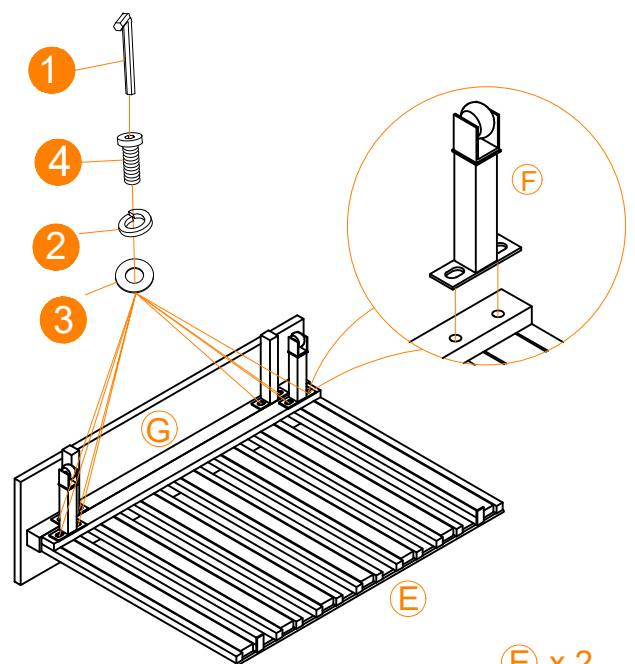
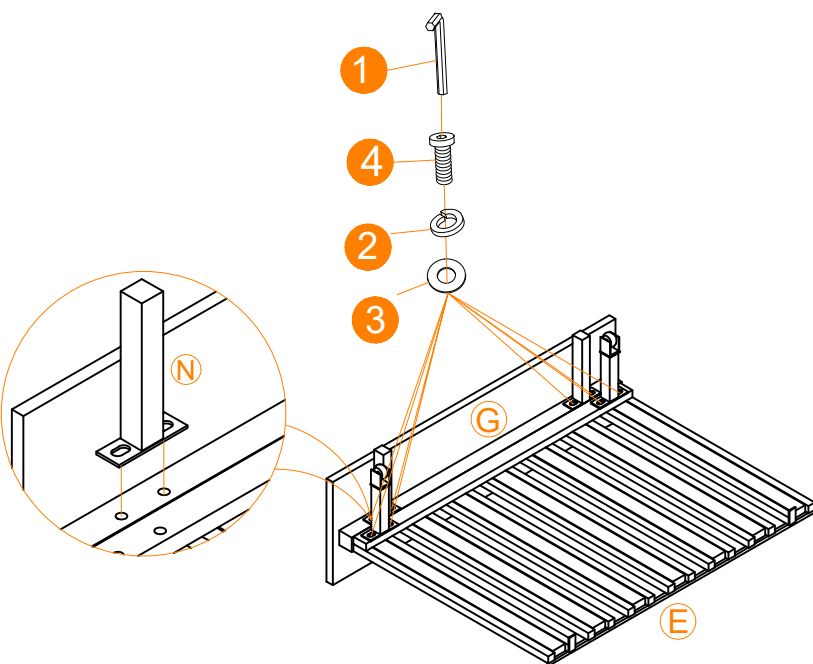
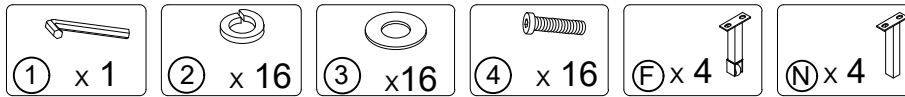

E x 2  
F x 4  
G x 2  
N x 4

9

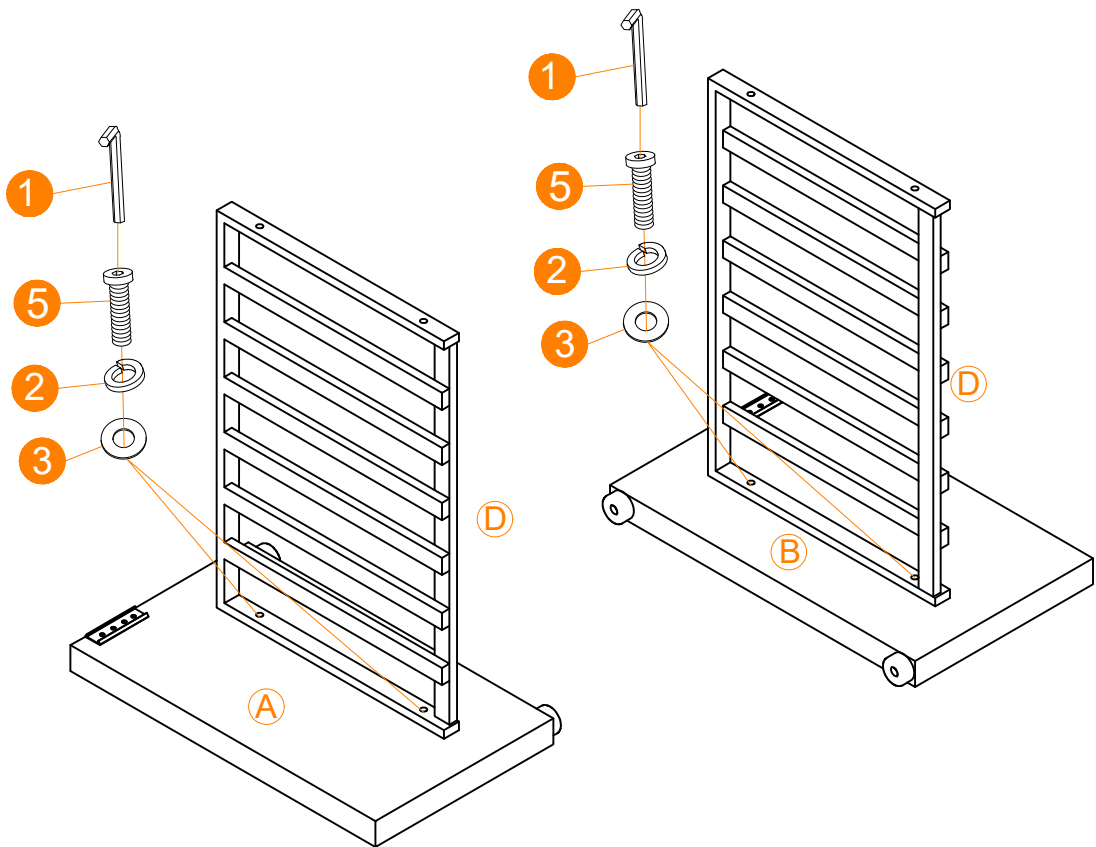
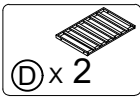
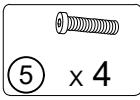
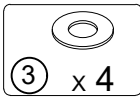
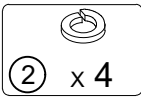
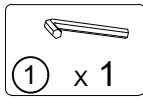

10

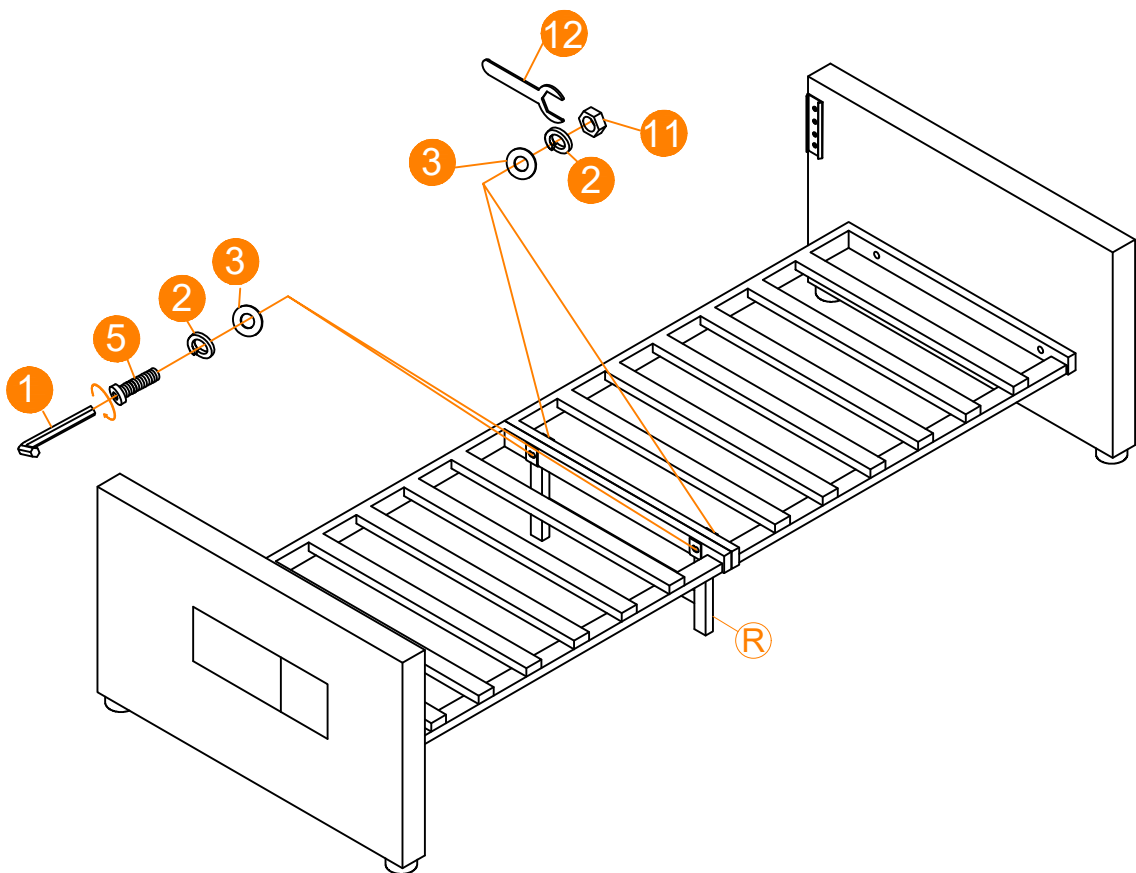
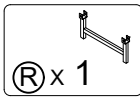
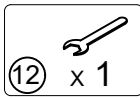
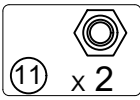
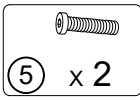
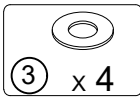
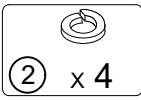
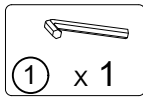

9

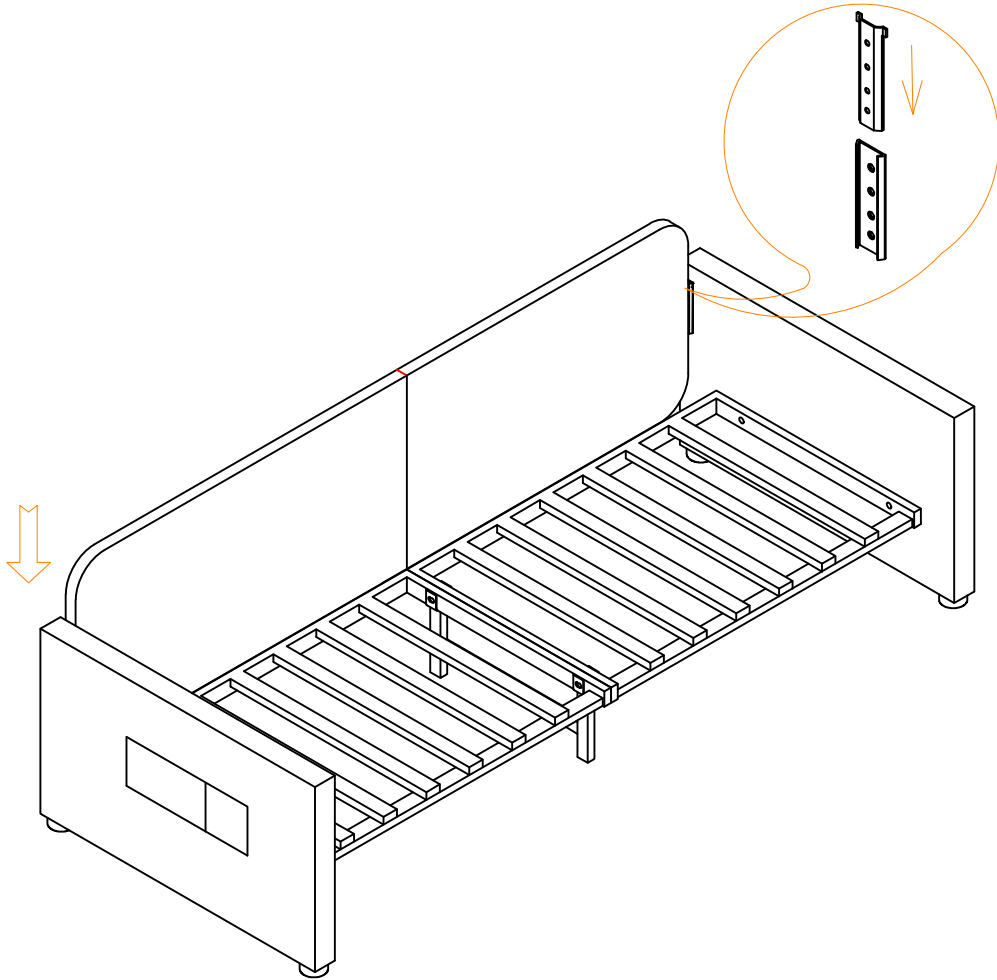

10

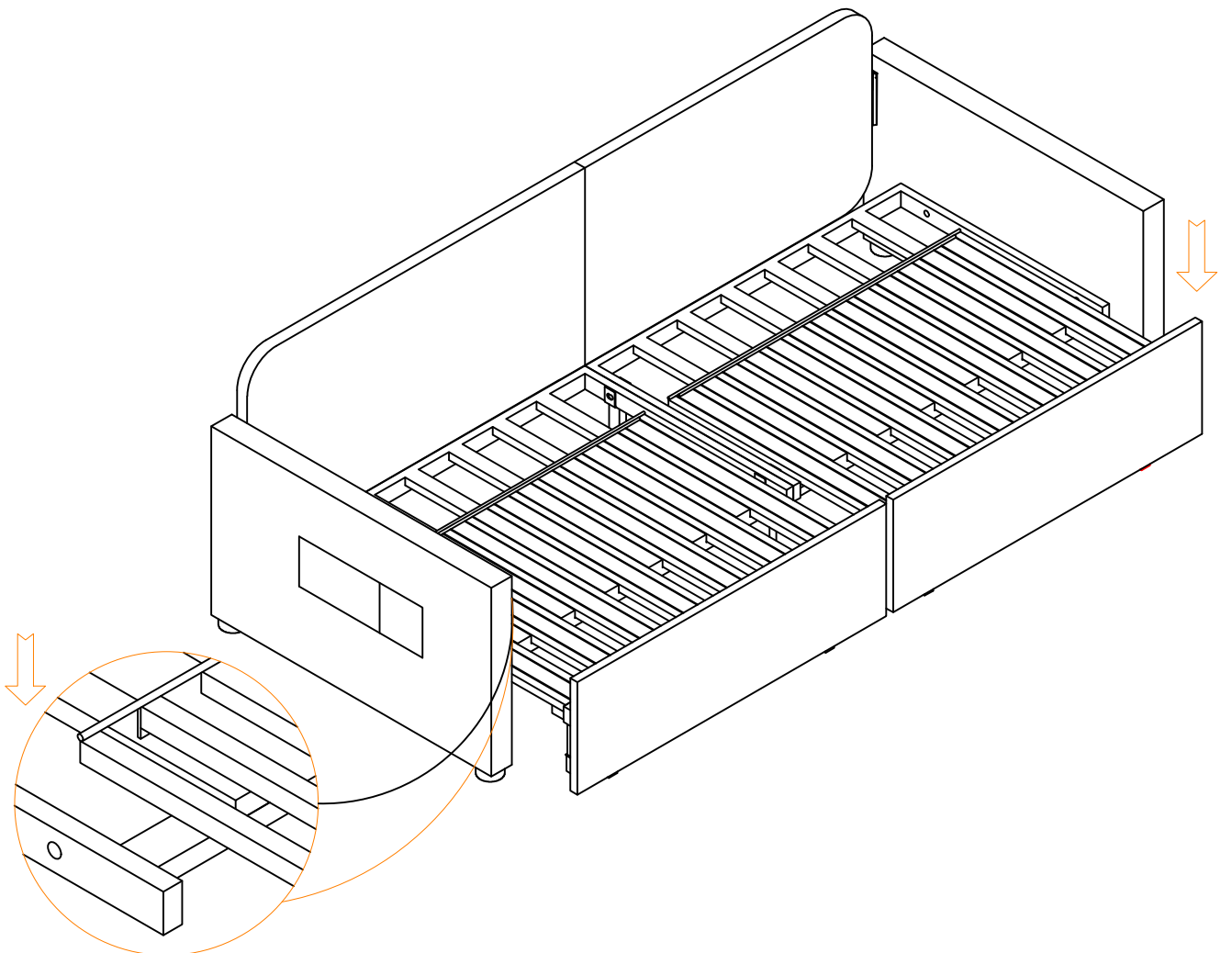

11

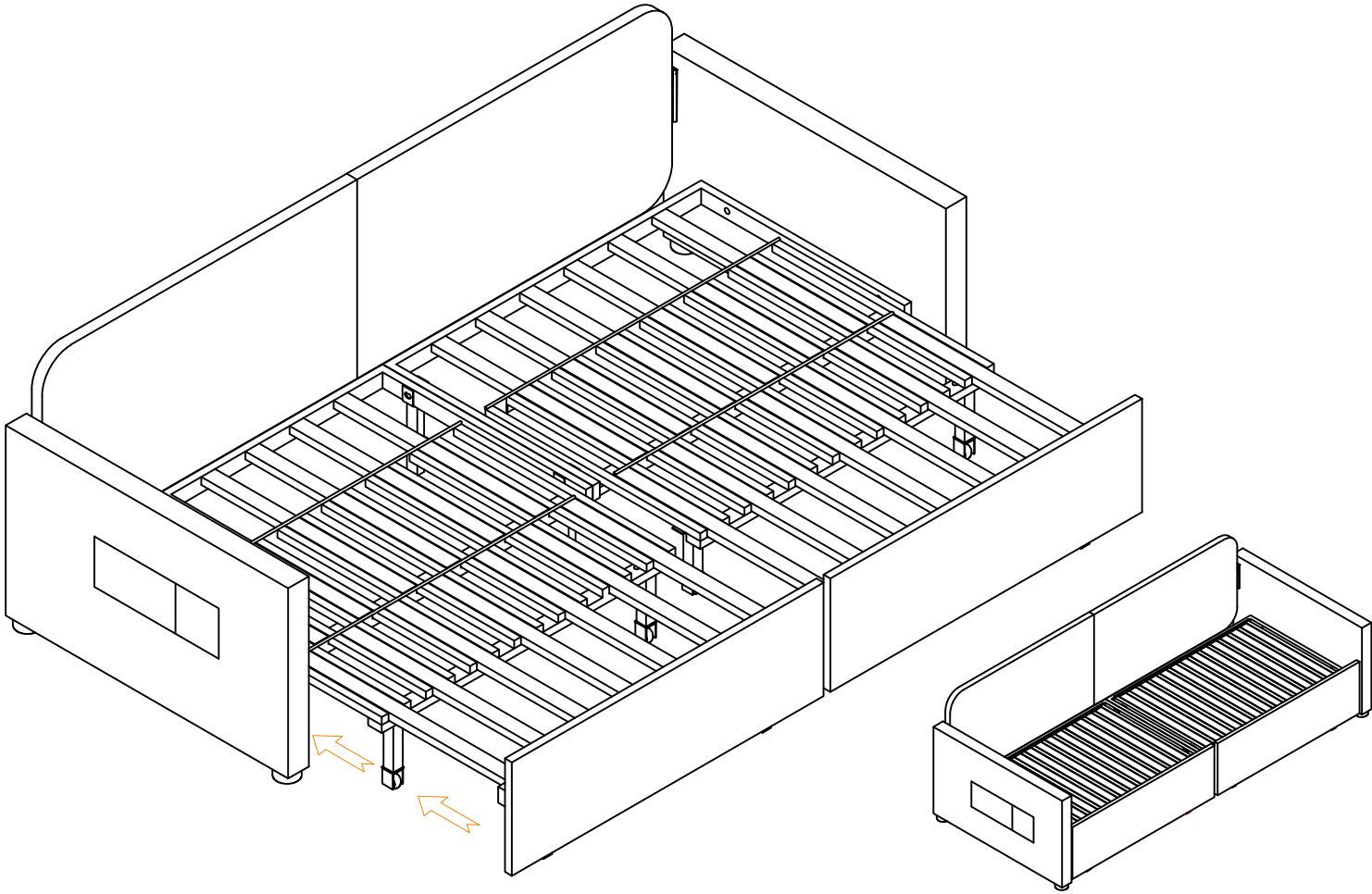

12

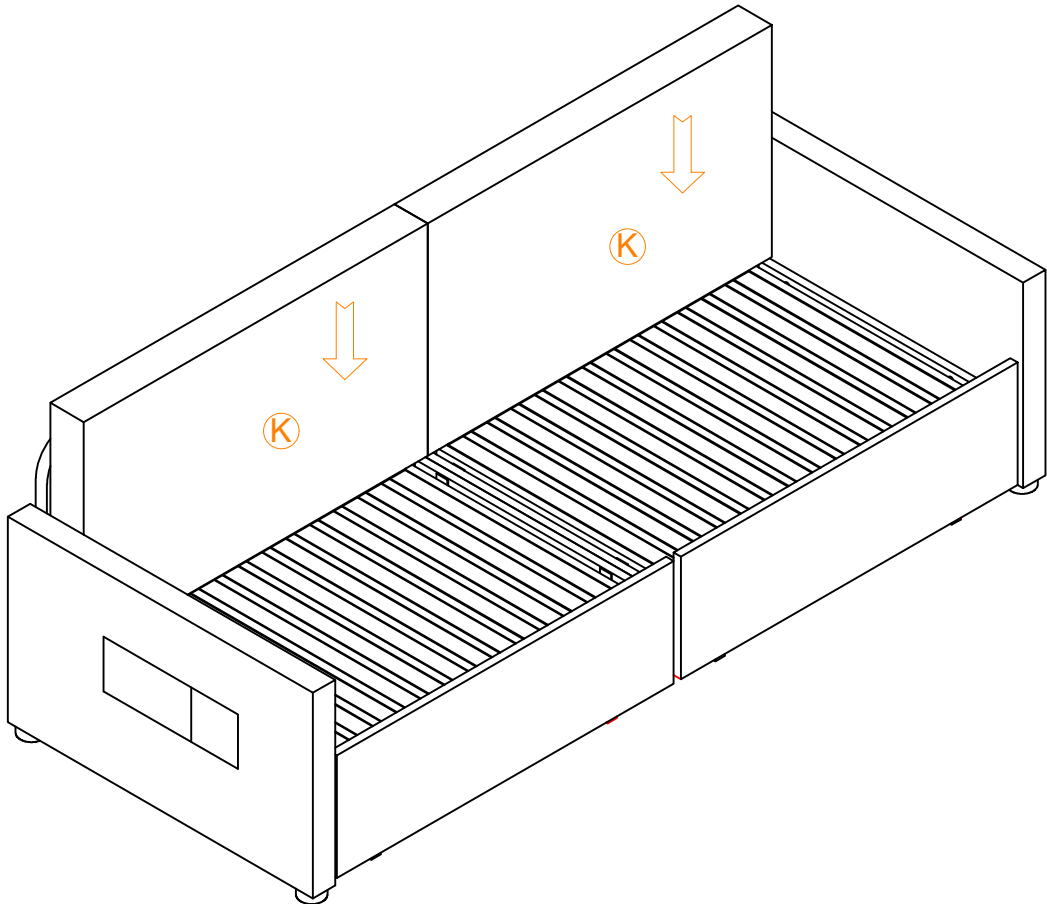
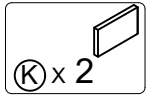

13

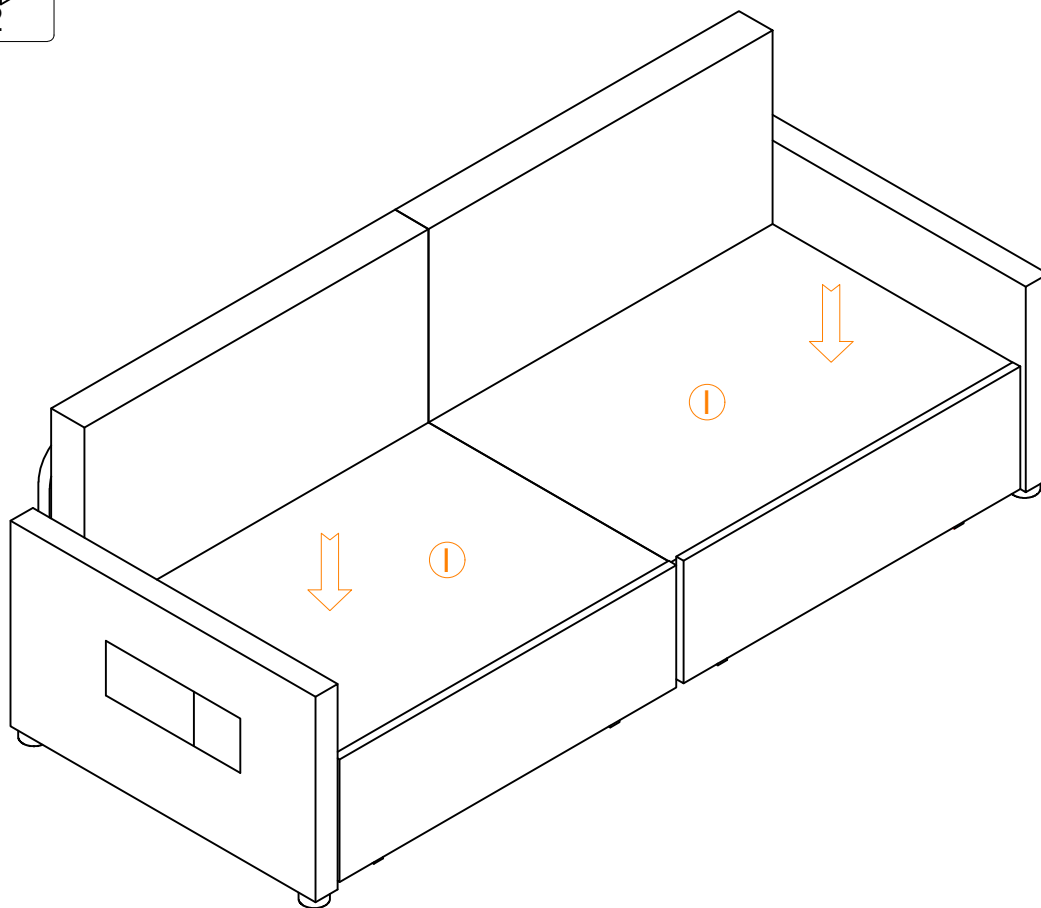
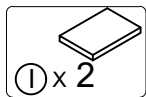

14

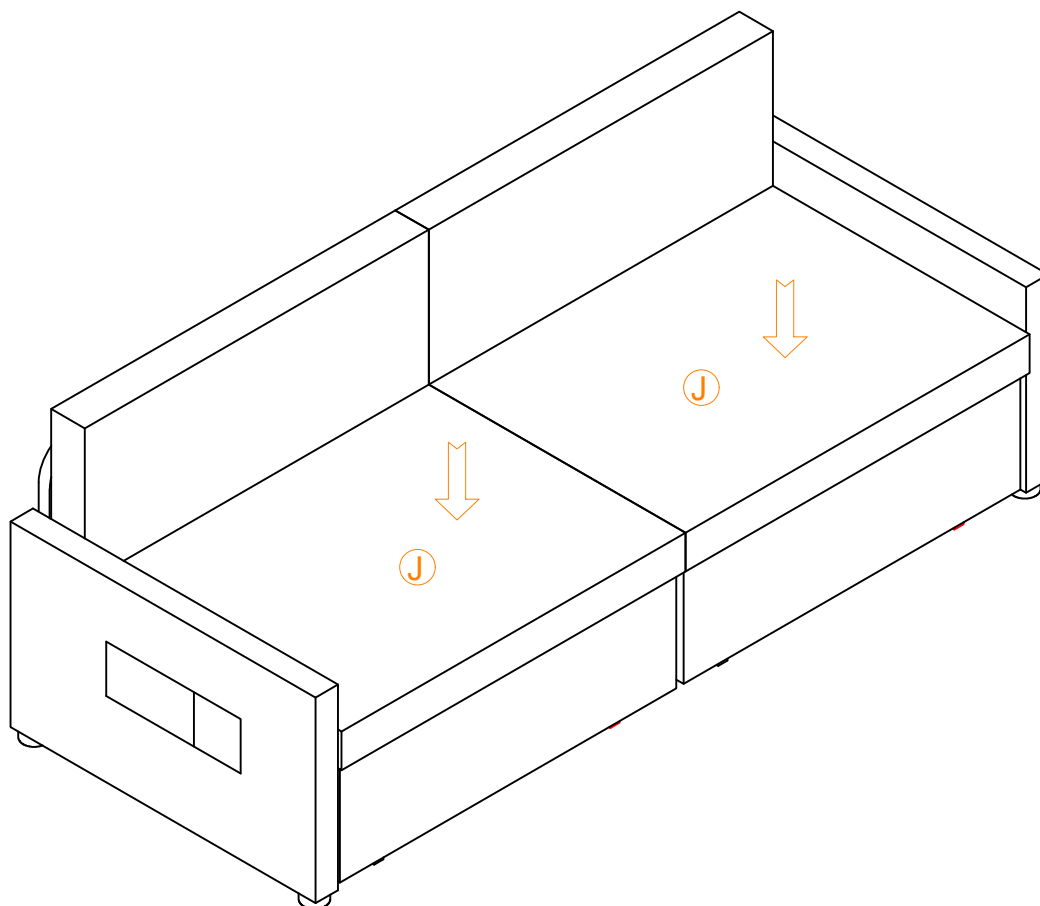
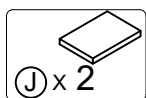

15

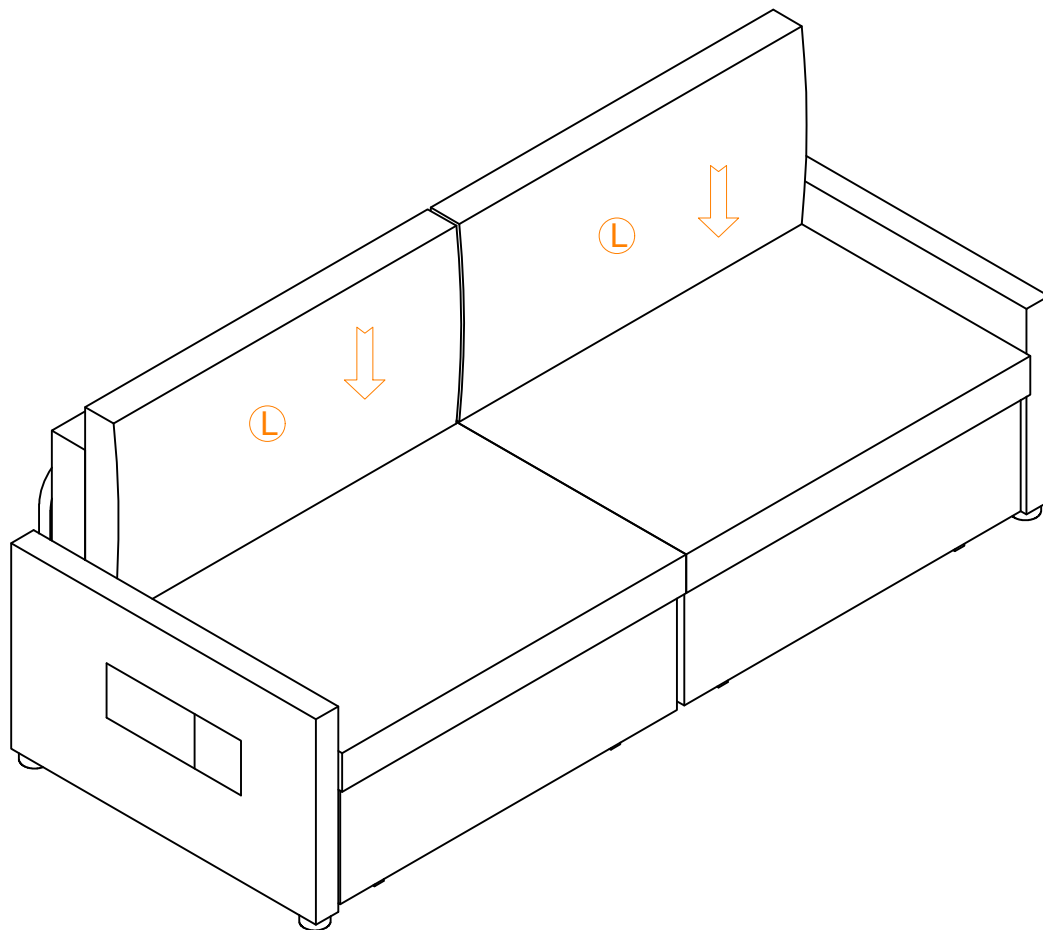
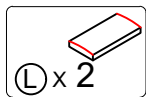

16

