

Sofa

Assembly Instruction - Please keep properly for future reference.

If you find any missing boxes, damaged parts, or accessory shortages, please contact the customer service team of your purchasing channel immediately. We will resolve the issue as quickly as possible.

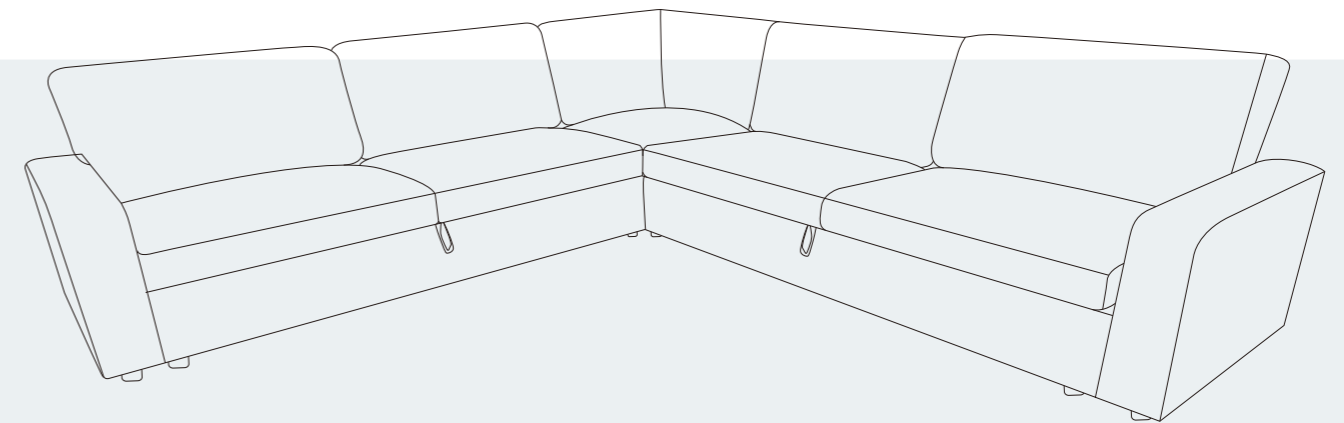

CONTACT US

- In order to receive assistance more quickly, please provide

THE FOLLOWING INFORMATION:

- Order number
- Purchase platform
- Purchase date
- Detailed description of the issue along with photos (if applicable)

Important - Please read these instructions carefully before starting the installation.

V1.0

EN

| Sofa

Before Assembly



Thank you for choosing our product!

To ensure a smooth installation process, please read this guide carefully to familiarize yourself with the required tools, materials, and installation steps.

Follow the relevant sections to avoid any damage caused by improper installation, and make sure to review all operation and safety guidelines for correct installation procedures.

Packaging Notice:

1. Multi-Box Shipping Notice

This product is packaged in 3 separate boxes for shipping and may arrive in batches at different times. To ensure a smooth assembly process, please make sure all boxes are received before unpacking and starting the installation.

2. Box and Packaging Verification

Each box is labeled with a corresponding number. Please refer to the packing list on the next page of this manual to verify that all boxes have been received.

If you find any missing boxes, damaged parts, or accessory shortages, please contact the customer service team of your purchasing channel immediately. We will resolve the issue as quickly as possible.

Installation Information

- All information in this guide is based on the product's condition at the time of printing. We reserve the right to modify product features, packaging, or availability without prior notice.
- Before installing the furniture, ensure that all necessary electrical or environmental preparations are completed.
- This manual contains important instructions on installation, cleaning, and maintenance. Please read it thoroughly and keep it for future reference.

Pre-Installation Checklist

1. Carefully inspect the new product for any damage or defects.
2. Ensure installation is carried out on a clean, flat surface to maintain balance and stability.

3. Avoid prolonged exposure of the product to damp environments or direct sunlight.
4. Handle with care during installation. Use protective materials (e.g., soft pads) to prevent scratches.
5. For any questions or technical support, refer to the customer service guide and contact the seller's customer service.

Usage and Maintenance Recommendations

1. Clean furniture regularly to maintain hygiene and prevent bacteria growth. Use a damp cloth that has been wrung out to avoid scratching the finish.
2. Avoid contact with acidic or alkaline corrosive liquids.
3. Do not use unauthorized replacement parts. For replacement parts, contact the manufacturer or distributor.
4. Do not machine wash or rinse any part of this product with water.



Safety Warnings

1. Warning Labels:

Do not remove warning labels on the product or packaging, and always follow the related instructions.

2. Regular Inspections:

Regularly check all parts of the product to ensure they are correctly installed, undamaged, and all connectors are securely tightened.

3. Safe Use:

Do not play on or under the sofa, and strictly avoid jumping or any actions that may harm the sofa or users.

4. Rope Hazard:

Do not attach ropes, hooks, straps, or other unintended items to any part of the product.

5. Guide Preservation:

Retain this manual for future reference.

6. Supervisory Responsibility:

Safety is a shared responsibility between the manufacturer and the user. Always adhere to safety guidelines when using the product.

Disclaimer

We are committed to providing safe and reliable products. If you have any questions about this product or require additional support, please contact our customer service team. We are here to assist you.

Customer Service Guide



Thank you for choosing our product! We are committed to providing you with excellent service. If you find any missing parts, damaged packaging, or product damage after receiving all packages, please follow the steps below to quickly contact our customer service team. We will do our best to resolve your issue.

1. Missing Parts

Verify Parts:

1. Refer to the “Parts List” in the manual to verify the name, specifications, and quantity of the missing parts.
2. Take a clear photo of the parts list and mark the missing parts with detailed information, e.g., “Missing 5 pieces of M6×30mm screws.”

Contact Us:**By Email:**

Send an email with the subject line “Missing Parts Issue.” Include the following in the email:

- A description of the missing parts and a photo of the parts list.
- Order details (order number, purchase platform, purchase date).

2. Product or Packaging Damage

If it affects normal use:**Steps:**

1. Take clear photos or videos showing the damaged parts and the extent of the damage (multi-angle shots are recommended).

2. Email the photos/videos along with order details with the subject line “Product Damage Issue.”

Resolution:

After verification, we will arrange for a replacement part, product exchange, or refund as quickly as possible.

If it does not affect normal use:**Steps:**

1. Contact our customer service team.
2. Provide a description of the damage and include relevant photos or videos.

Resolution:

We will provide repair guidance or an appropriate compensation plan based on the specific situation.

Helpful Tips

To process your issue efficiently, please prepare the following information:

- Order details (order number, purchase platform, purchase date).
- Clear photos or videos.
- We are committed to providing quick and professional solutions, no matter the size of the issue, to ensure your satisfaction.

**Thank you for your trust and support!
We hope you enjoy using our product!**

Parts List



Box 1

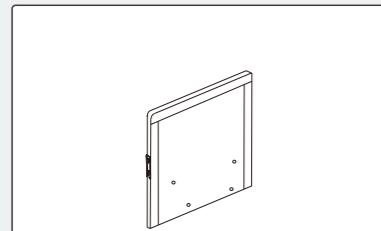

05 x1

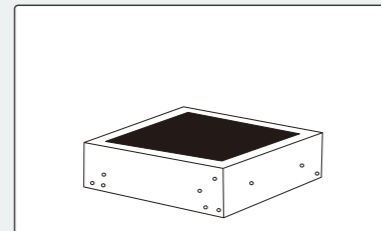

06 x1

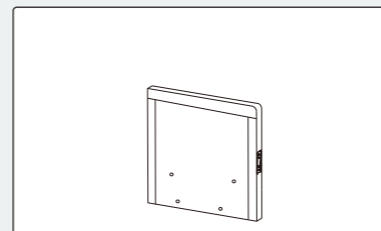

07 x1

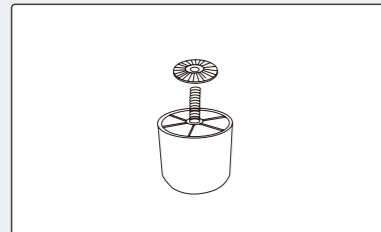

11 x12

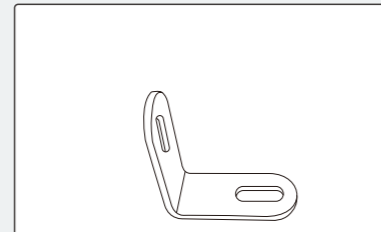

12 x4

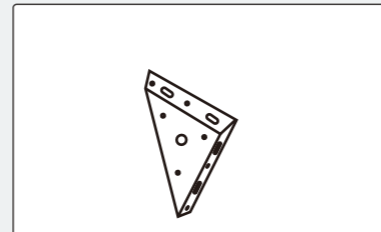

13 x2

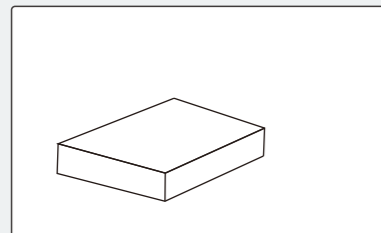

14 x3

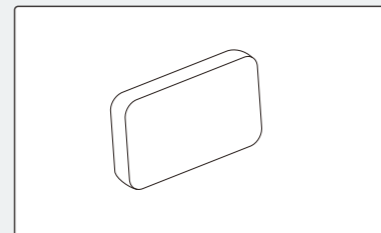

15 x1

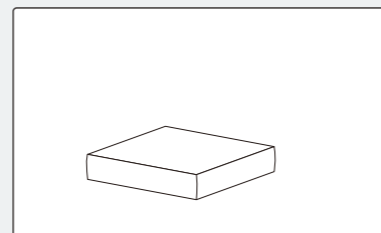

17 x1

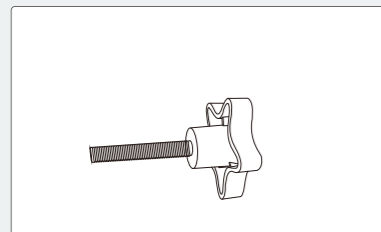

18 x4

Hardware List (in Box 1)

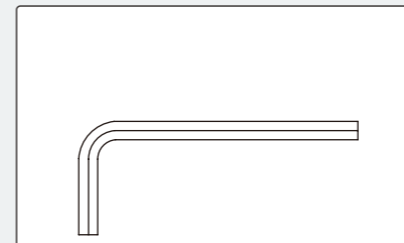

A M6 x1

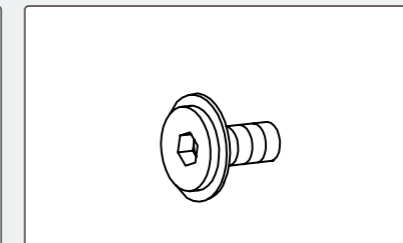

B M6x20mmx16

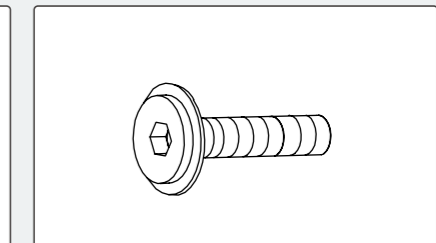

C M6x40mmx8

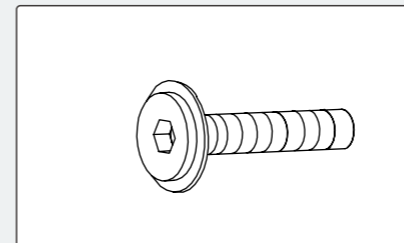

D M6x50mm x4

Box 2

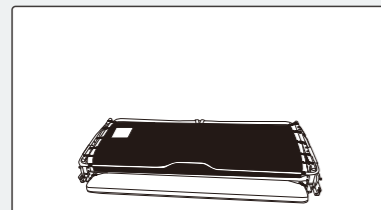

02 x1

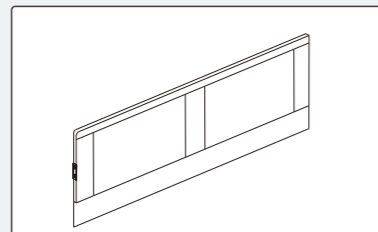

04 x1

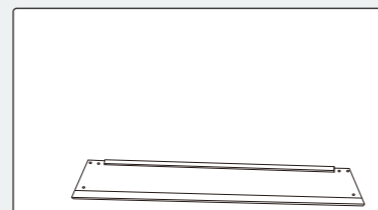

08 x1

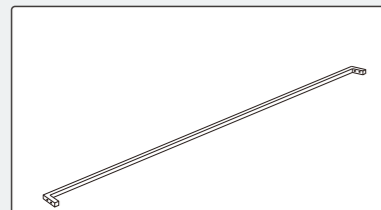

10 x1

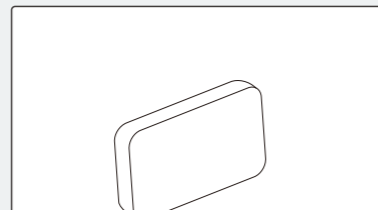

15 x2

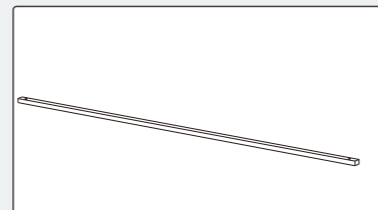

19 x1

Box 3

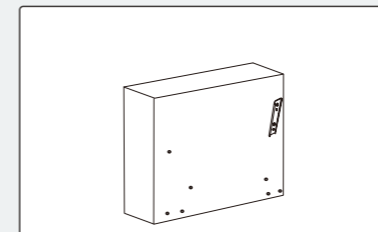

01 x1

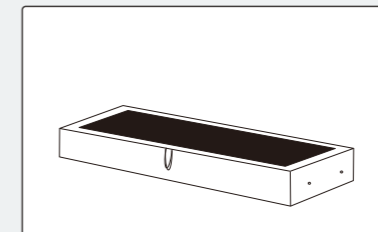

03 x1

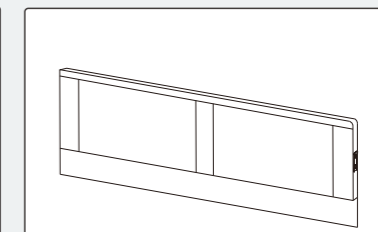

04 x1

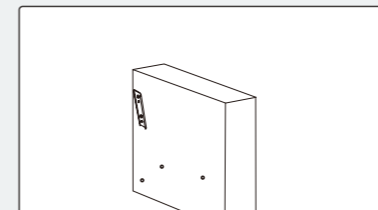

09 x1

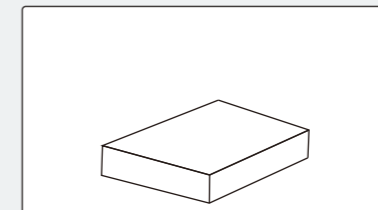

14 x1

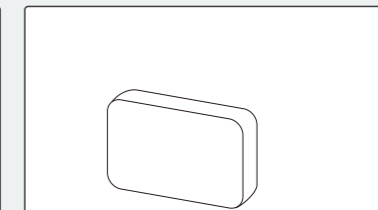

15 x1

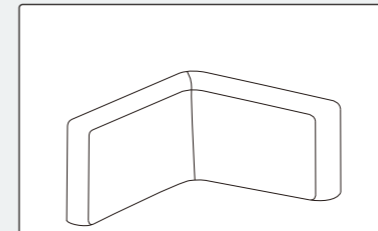

16 x1

Exploded View

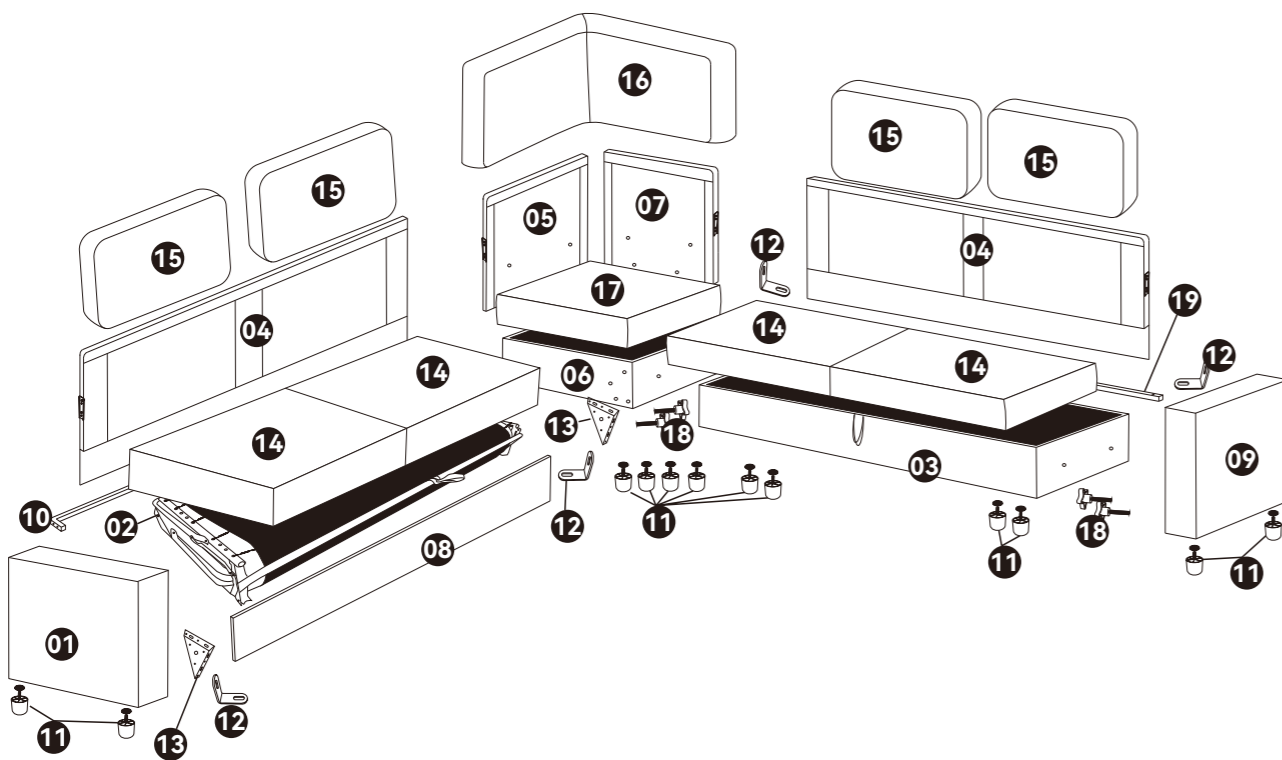
**Important Notes:**

This product requires two people for assembly. The estimated assembly time is within one hour. The product is heavy, so please handle it with care.



The protective fabric on the back Nylon Fastener of parts 14, 15, 16, and 17 must be removed before adhesion.

Assembly Instructions



! **Important :** Please read these instructions fully before starting asembly.

! **Note :**

Delivered with **THREE PACKAGES** with **THREE TRACKINGS**, may **NOT** be delivered at the same time.

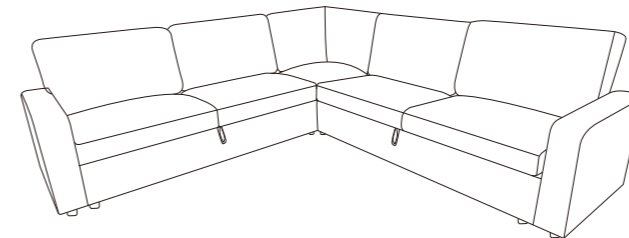

Before starting asembly, determine where the sofa will be placed and the orientation you want it to be.



2 people needed

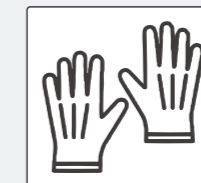

Work gloves



Tape measure

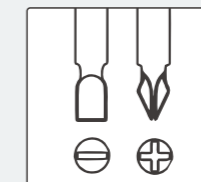

Other Tools Required
Phillips Screwdriver
(Not Included)

Simple Assembly Steps

1. Read the manual carefully.
2. Check all parts and hardware.
3. Prepare necessary tools.
4. Have at least two adults for assembly.

Please follow the instructions and use a sanitary napkin to protect the product during your assembly process.

Note:

1. The assembly should be done on a flat surface to maintain balance.
 2. Do not tighten the screws before the assembly is complete.
- To make the assembly process easier and better, two or more adults are needed.

Chaise - Exploded View

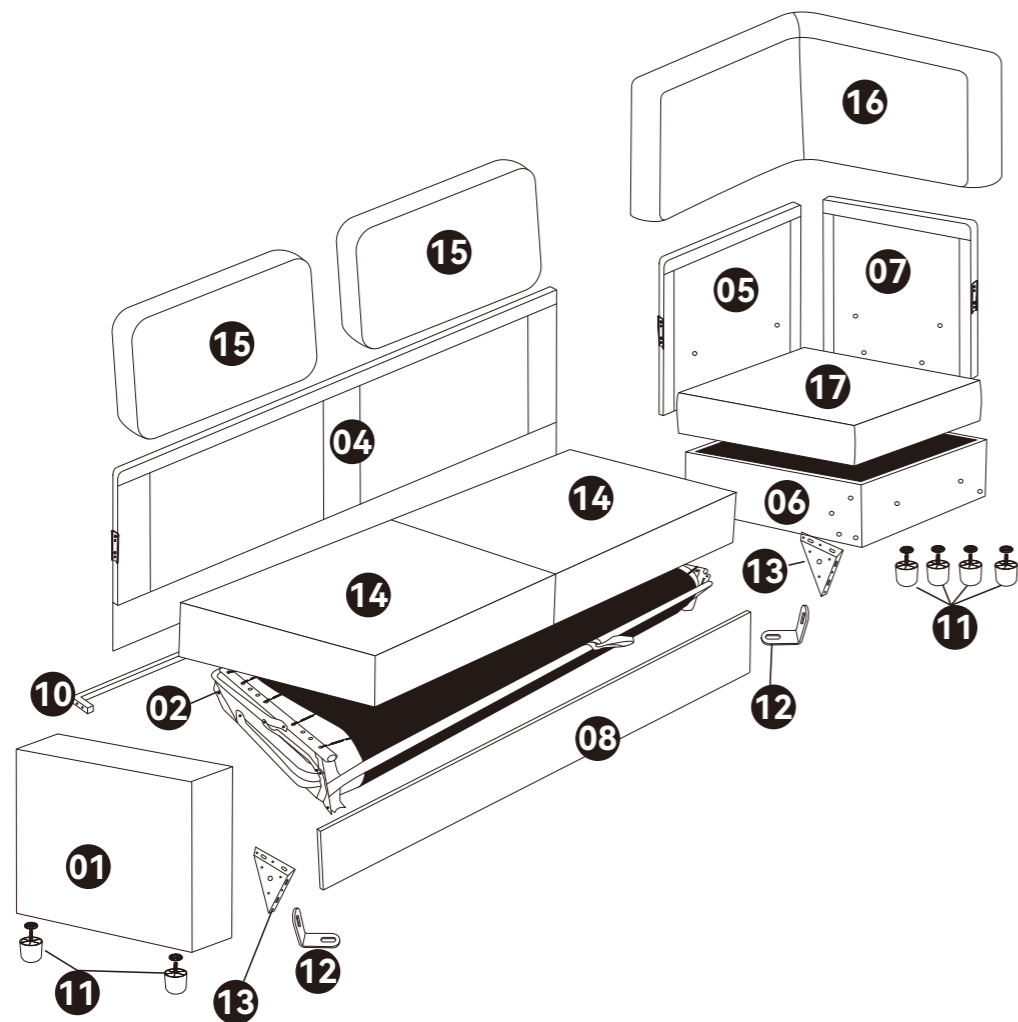

01 x1	02 x1	04 x1	05 x1	06 x1	07 x1	08 x1
10 x1	11 x6	12 x2	13 x2	14 x2	15 x2	16 x1
17 x1	<p>Important Notes: This product requires two people for assembly. The estimated assembly time is within one hour. The product is heavy, so please handle it with care.</p>					

Step 1

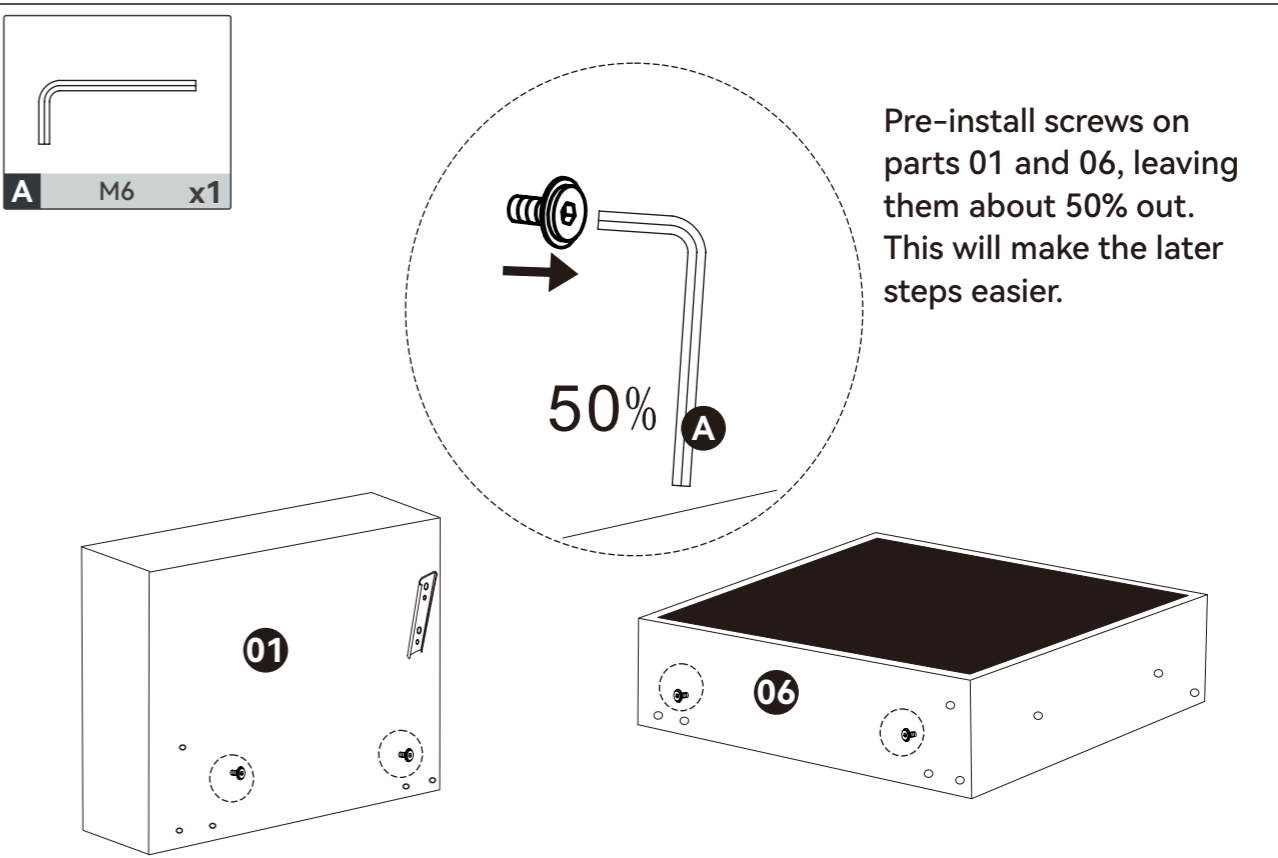

Step 2

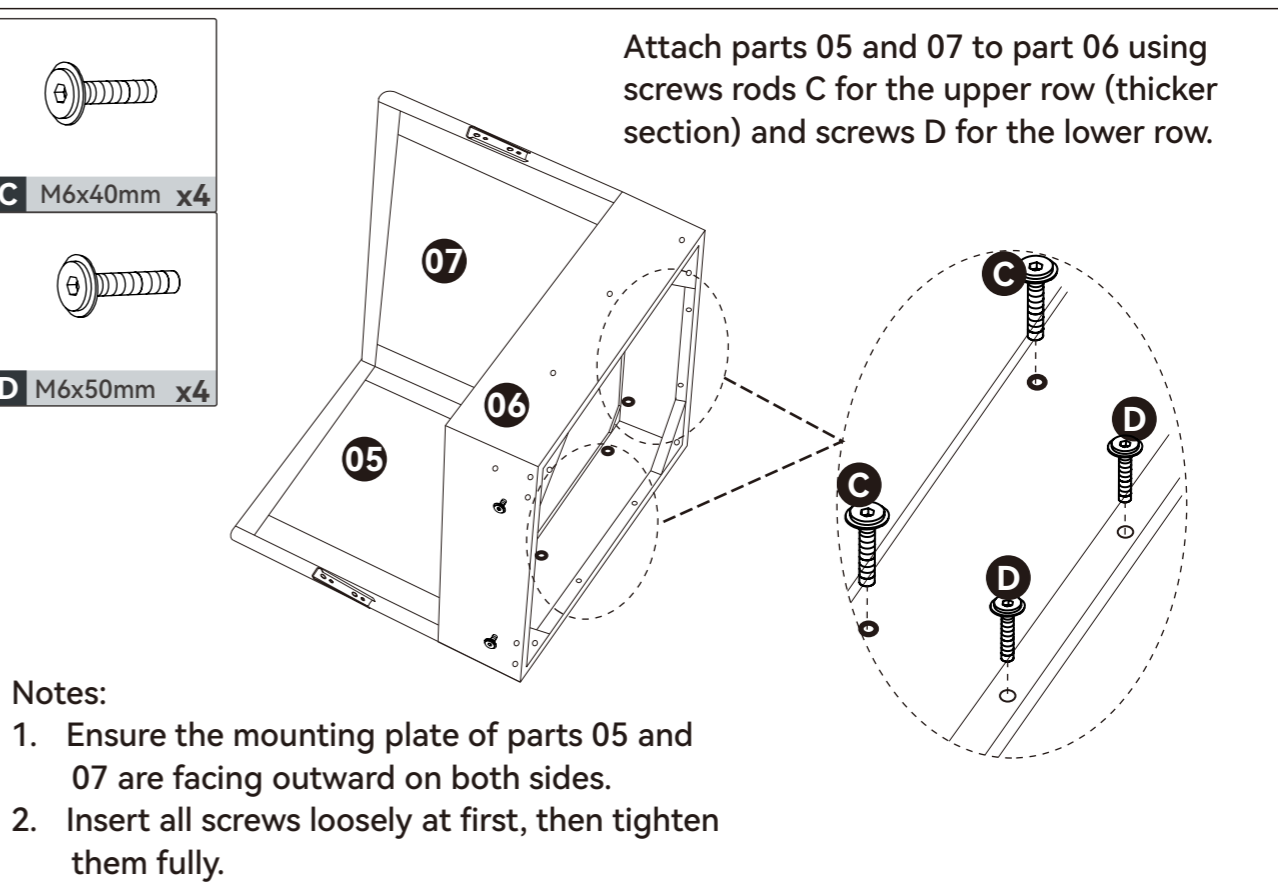

Step 3

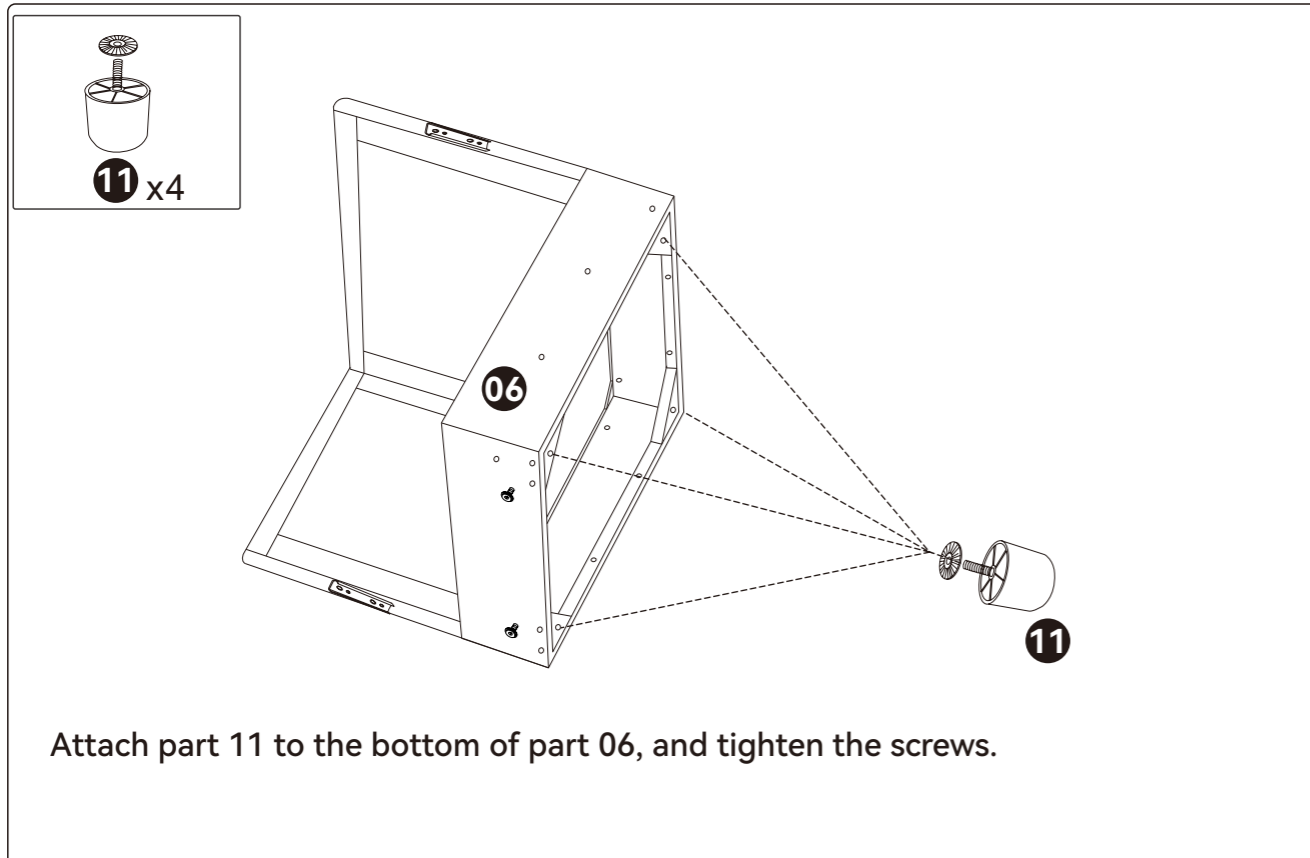

Step 4

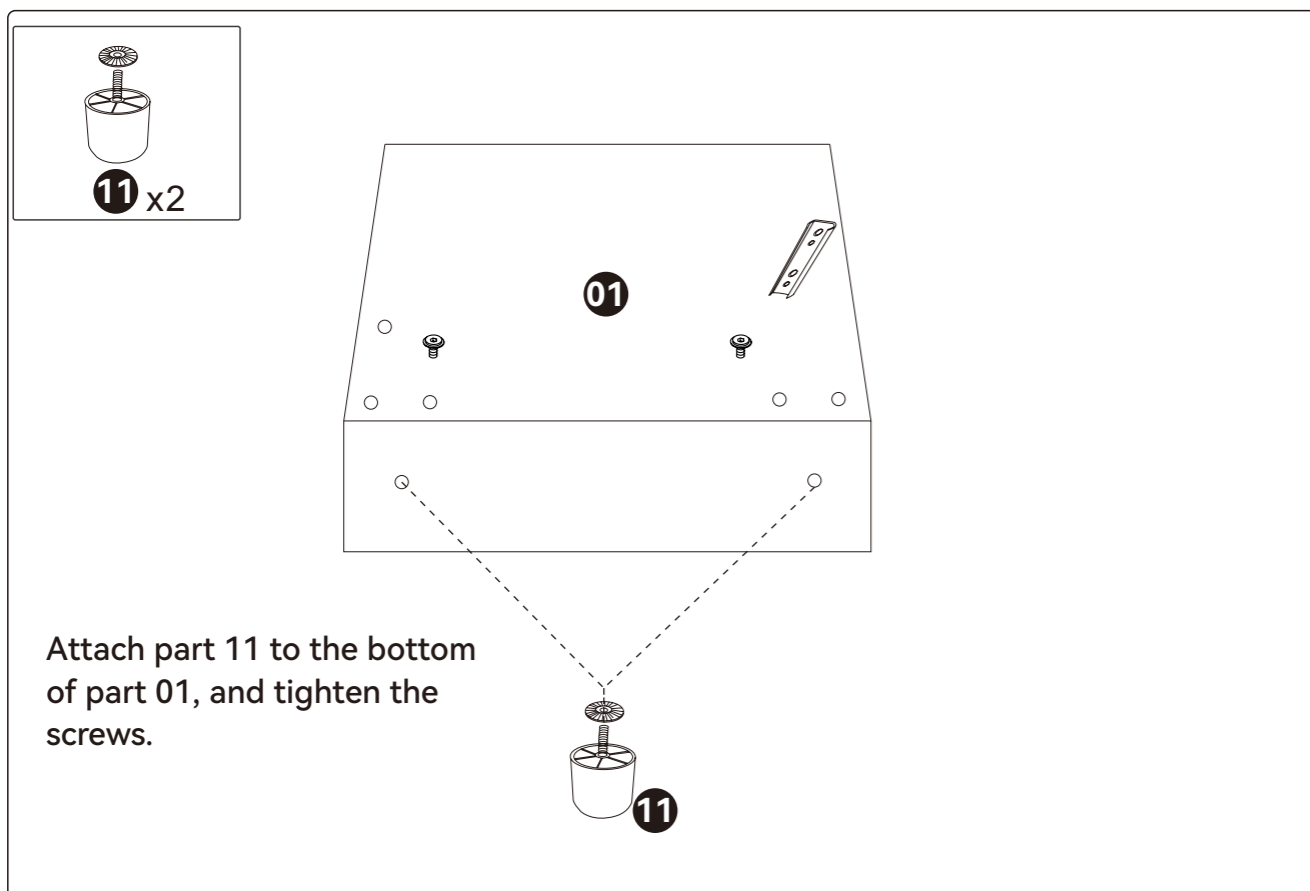

Step 5

Connect part 04 to parts 01 and 05.

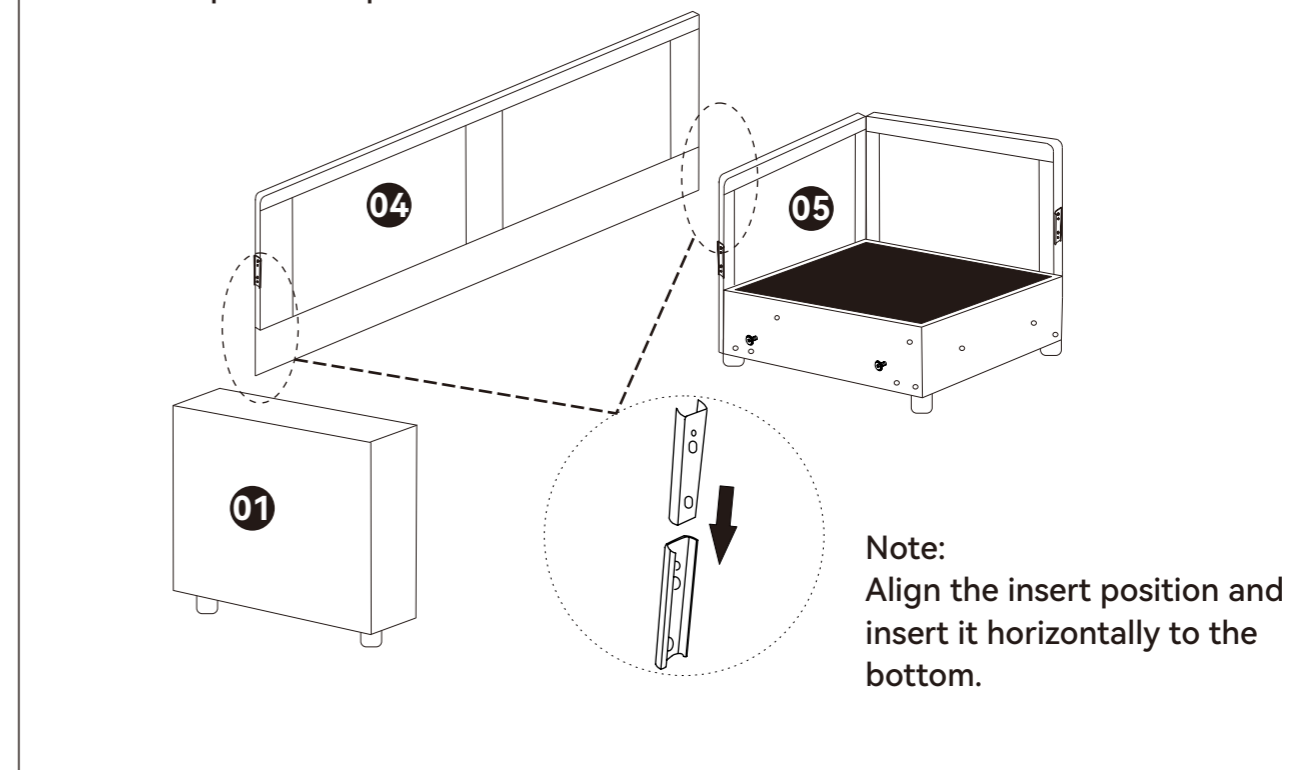

Step 6

Insert the slot of part 02 onto the inner pre-installed screws on parts 01 and 06.

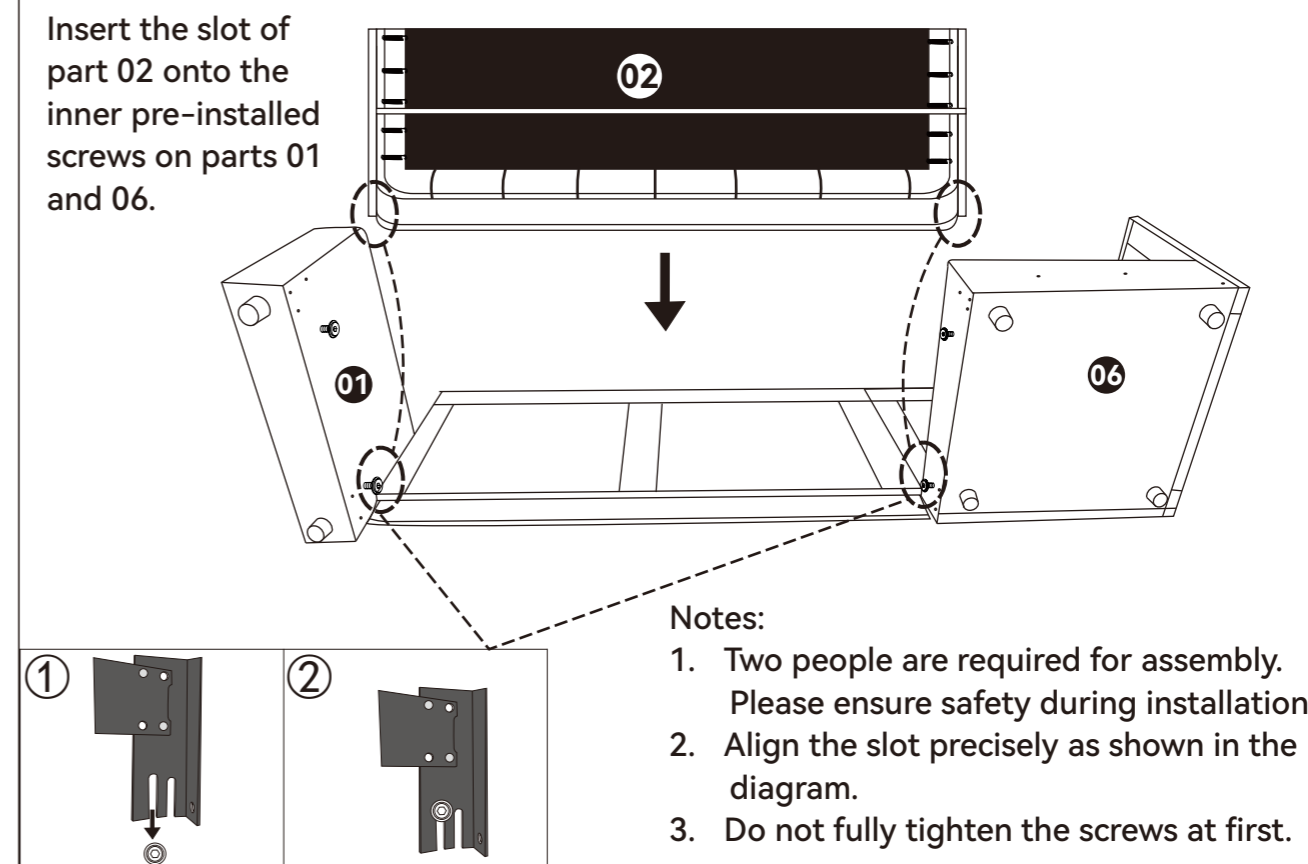

Step 7

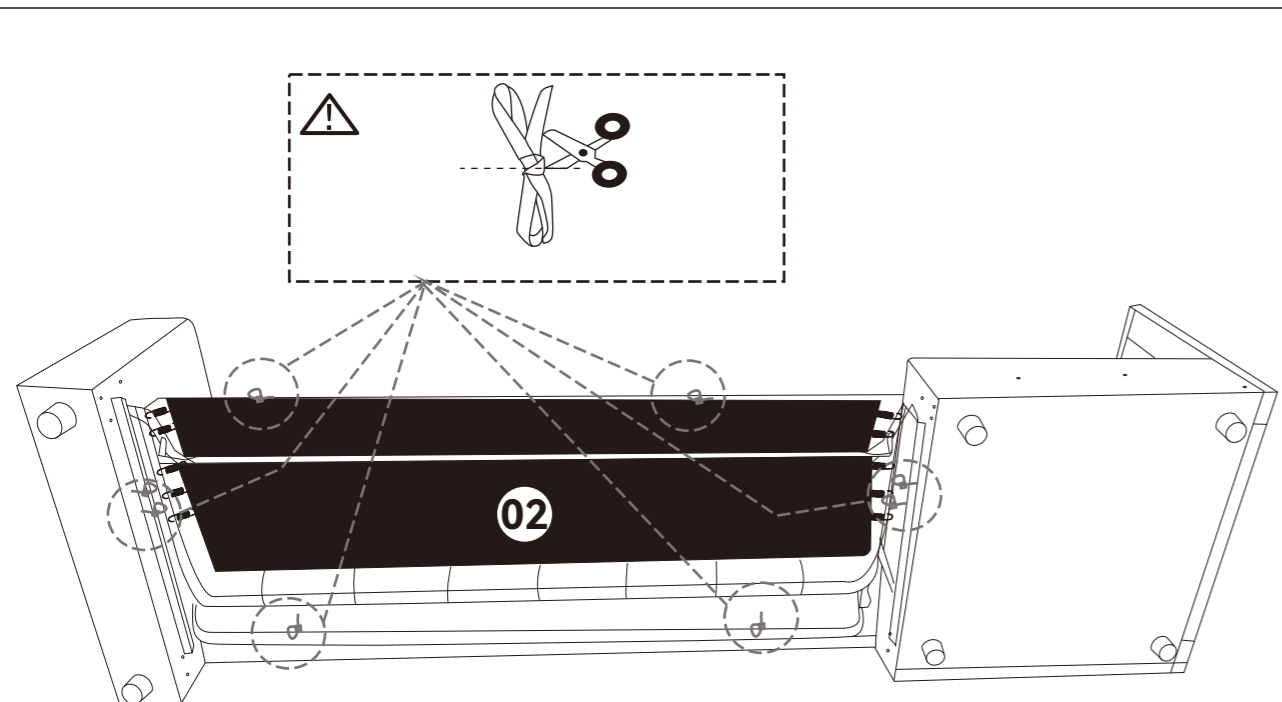

Cut the straps around part 02 and open the first layer of hinges. Use caution when cutting.

Step 8

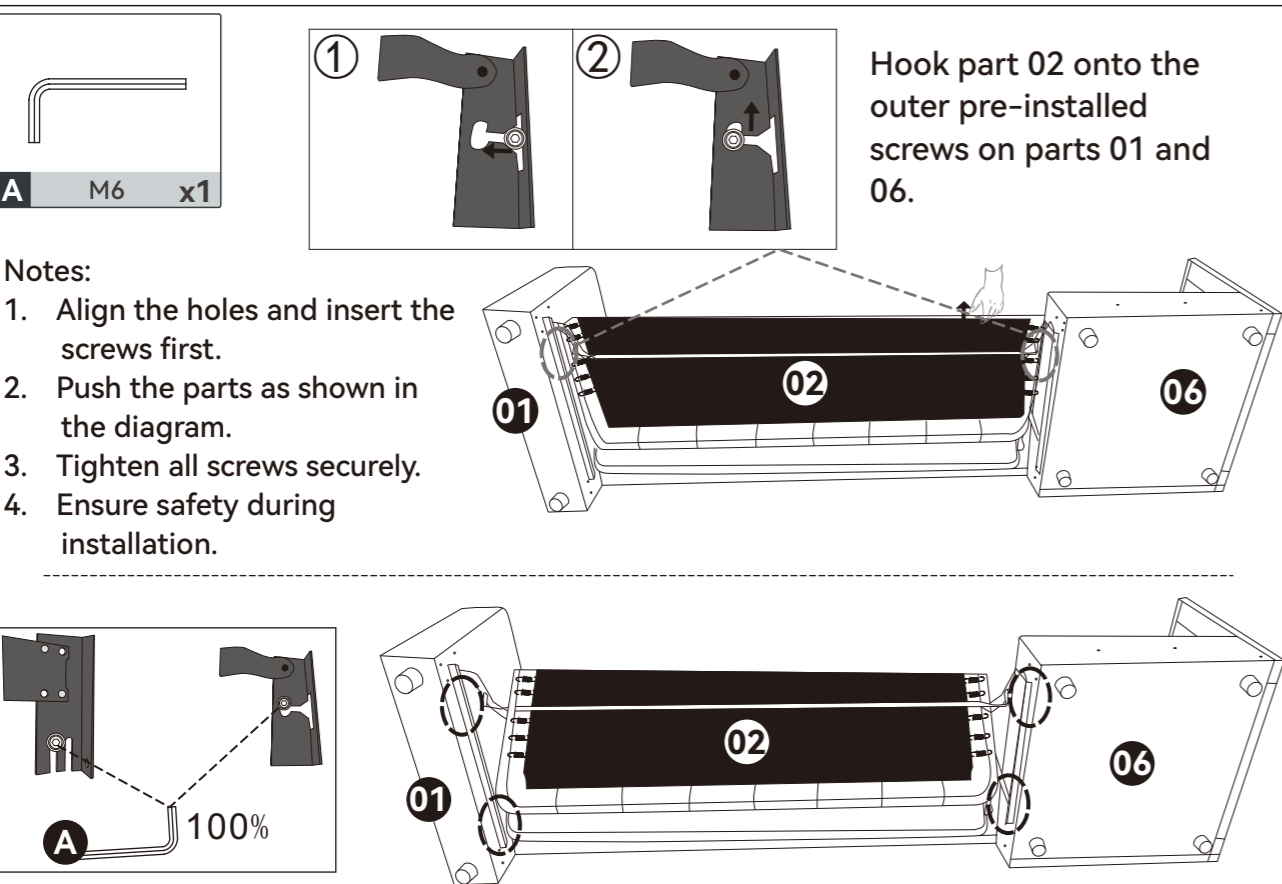

Step 9

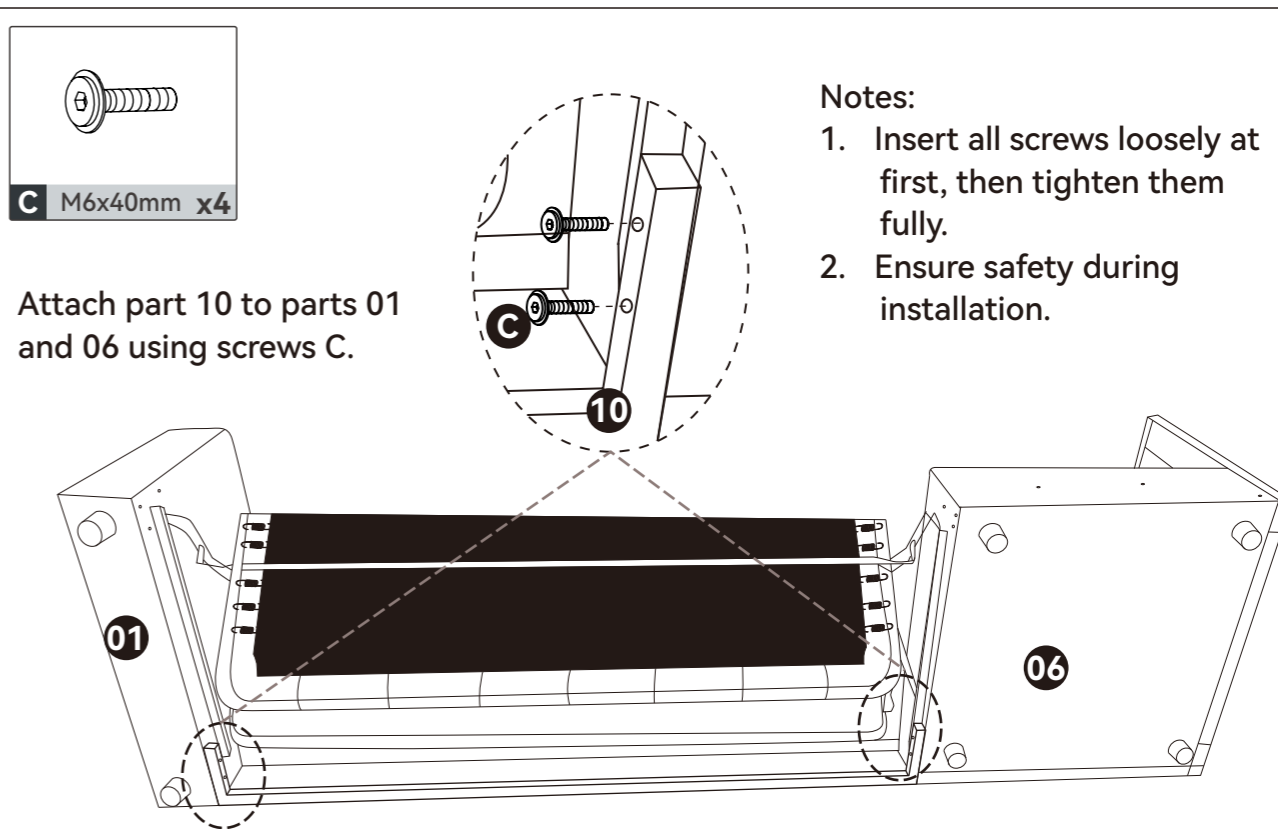

Step 10

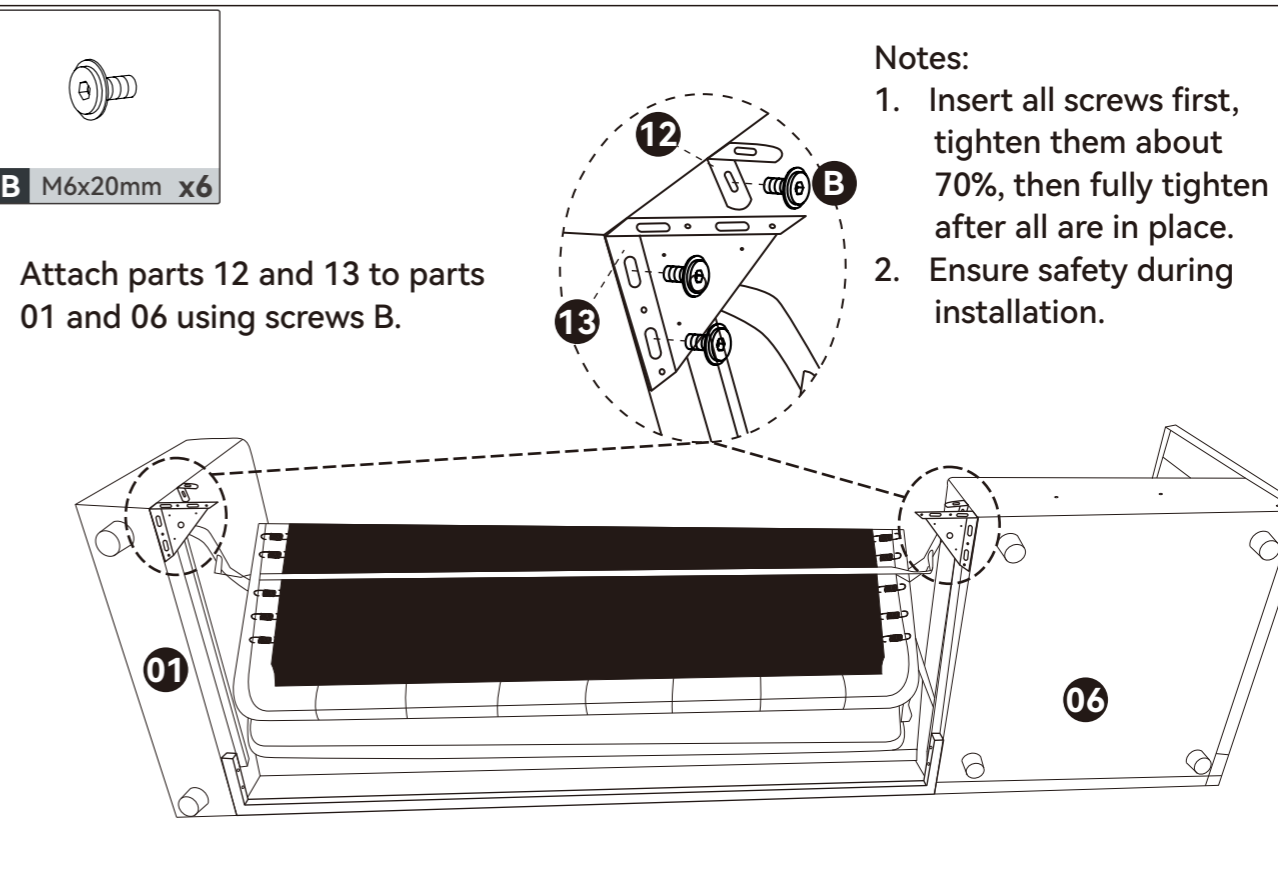

Step 11



B M6x20mm x6

Install part 08 onto parts 12 and 13, and secure it with screw B.

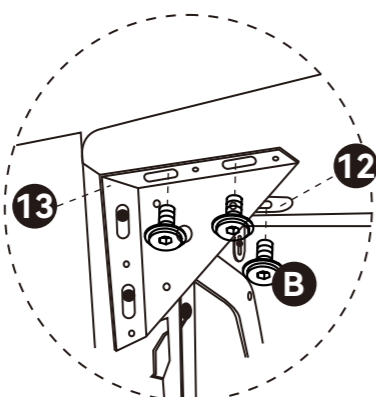

Note:

1. When installing part 08, pull parts 01 and 06 outward on both sides.
2. First insert and loosely fasten all screws, including those that were previously not tightened, then tighten them all securely.
3. Please pay attention to safety during installation.

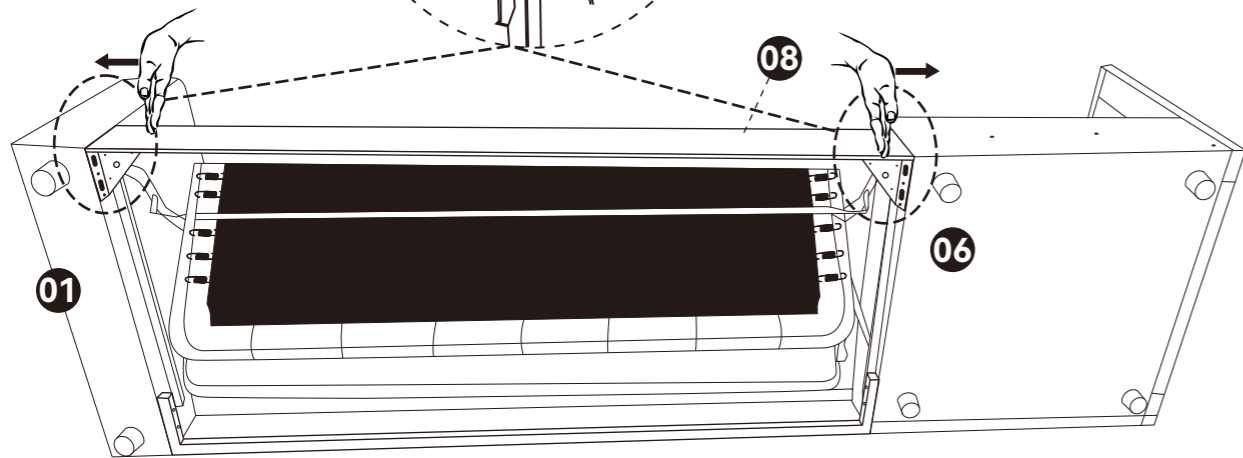

Step 12

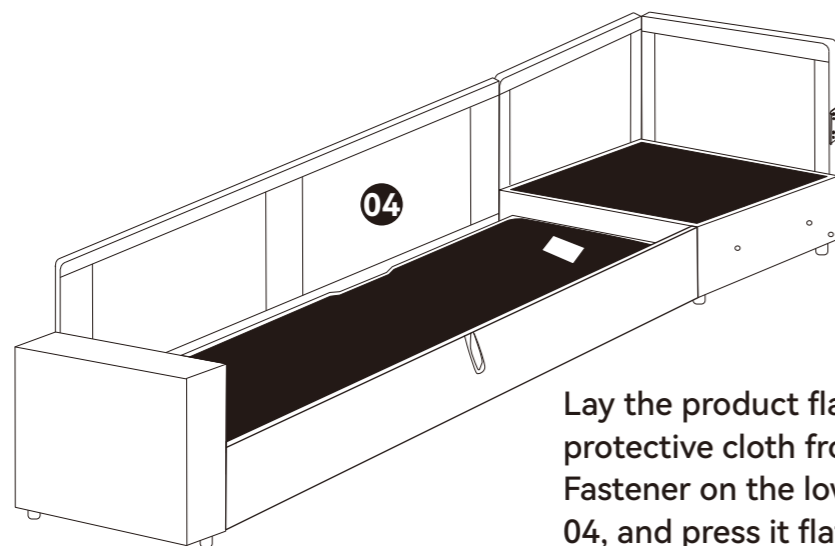
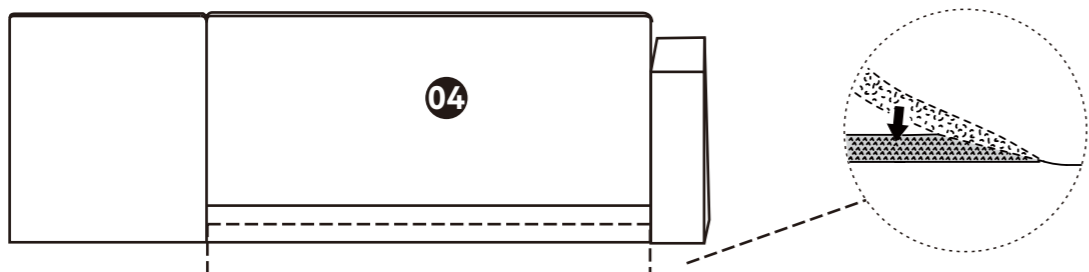

Lay the product flat, tear off the protective cloth from the Nylon Fastener on the lower back of part 04, and press it flat.

2 - Seater - Exploded View

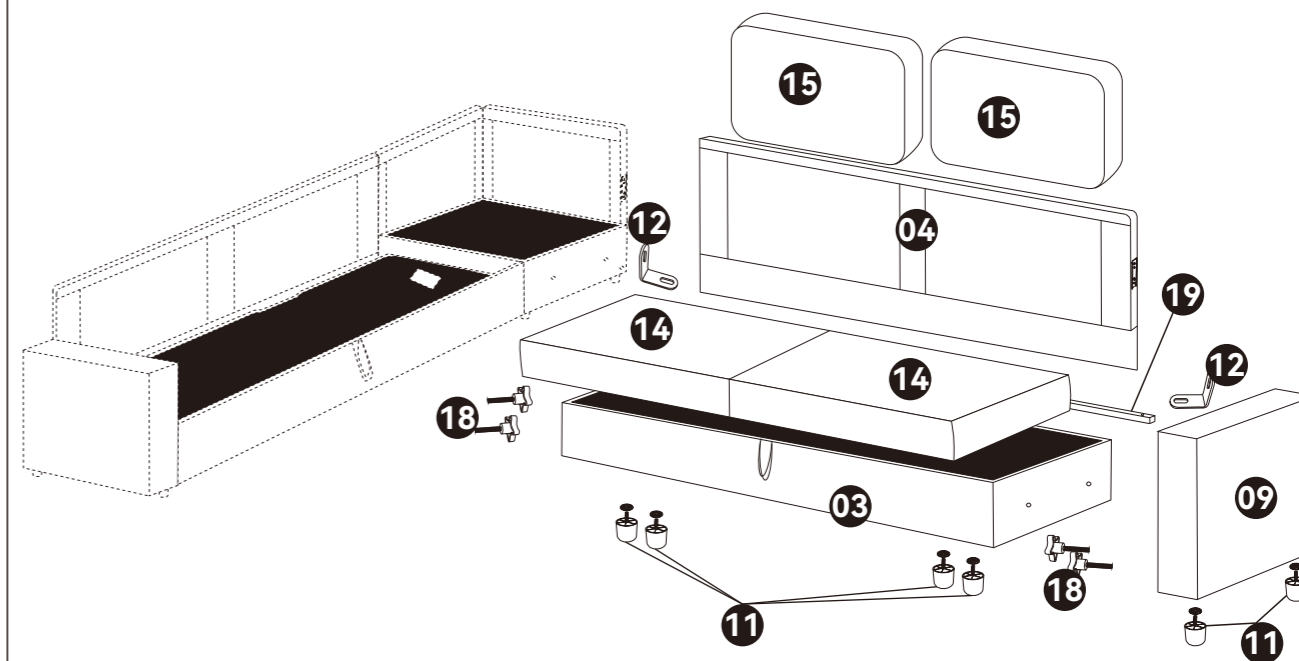

03	04	09	11	12	14
	x1	x1	x6	x2	x2
15	18	19			
x2	x4	x1			

Step 13

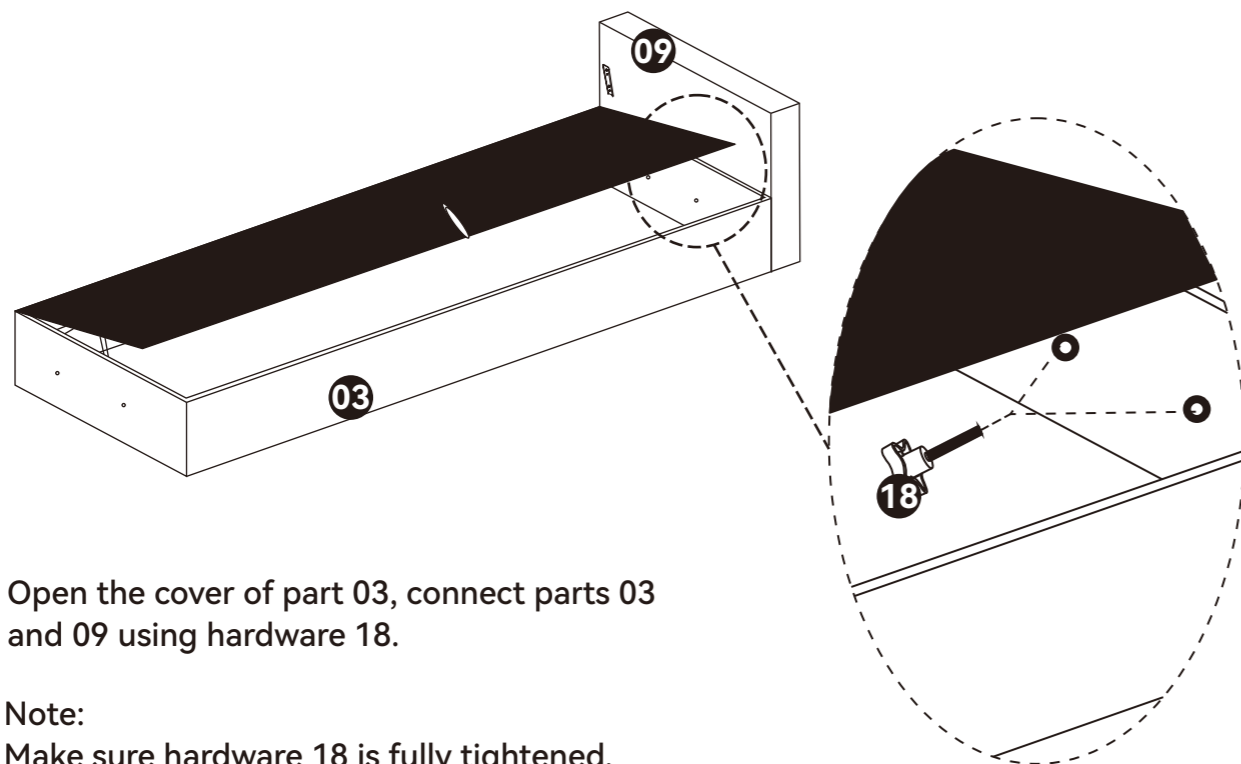

Open the cover of part 03, connect parts 03 and 09 using hardware 18.

Note:
Make sure hardware 18 is fully tightened.

Step 14

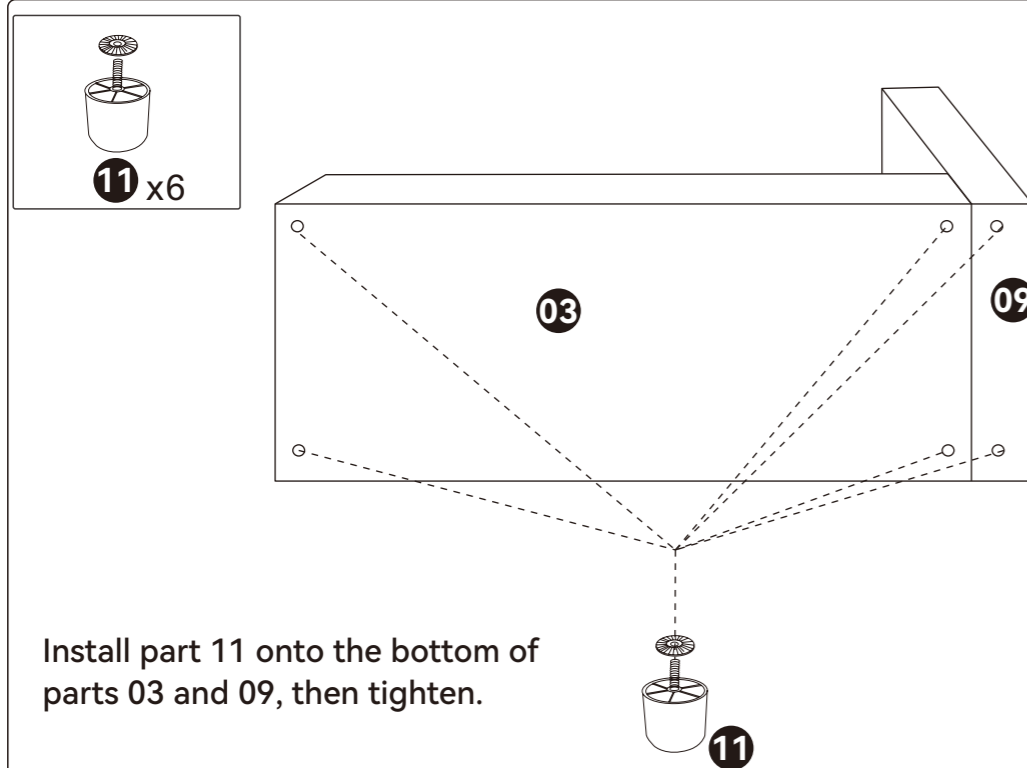

Install part 11 onto the bottom of parts 03 and 09, then tighten.

Step 15

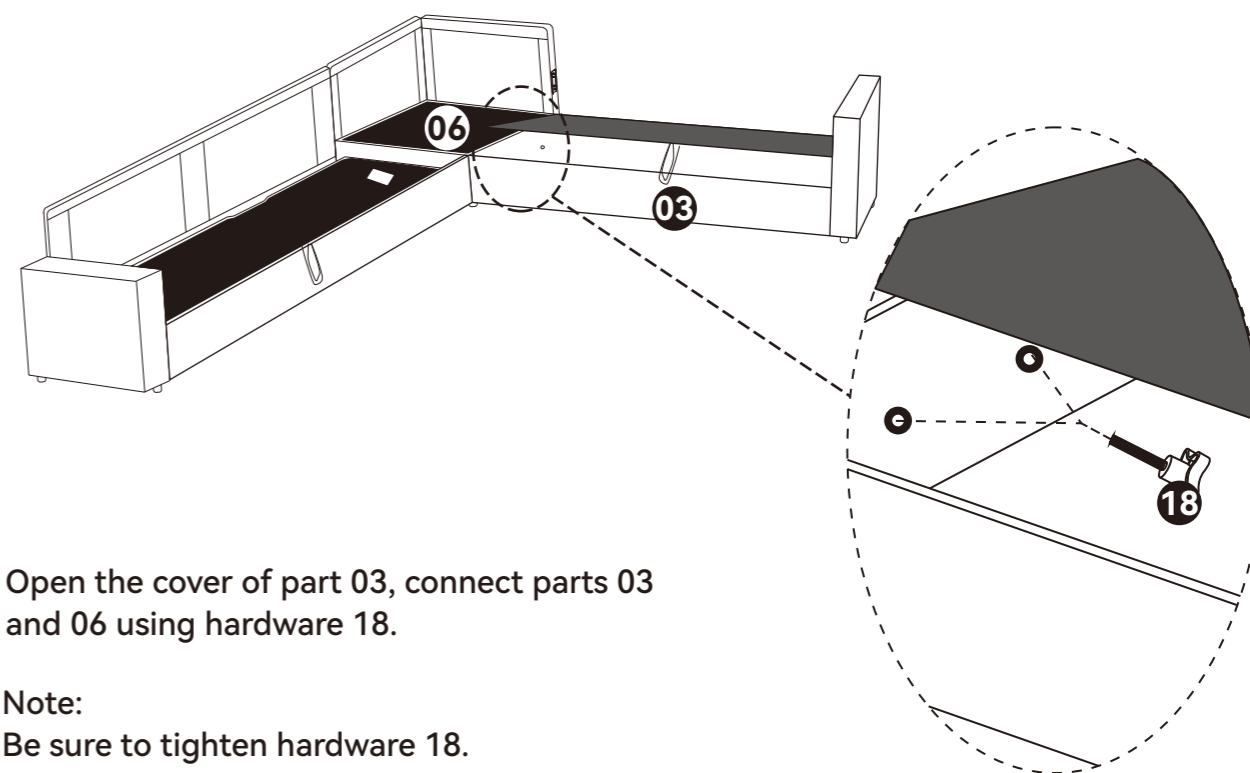

Open the cover of part 03, connect parts 03 and 06 using hardware 18.

Note:
Be sure to tighten hardware 18.

Step 16

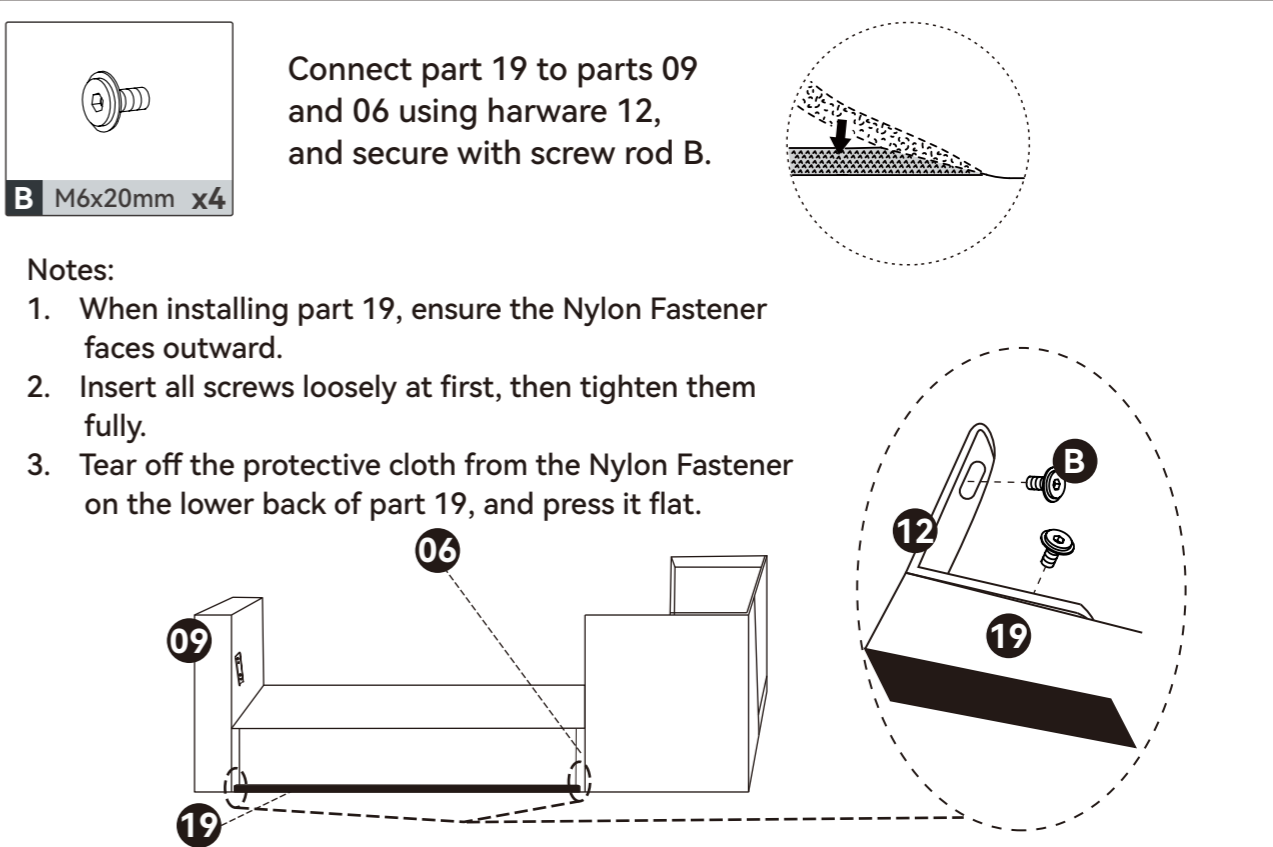

Connect part 19 to parts 09 and 06 using hardware 12, and secure with screw rod B.

B M6x20mm x4

Notes:

1. When installing part 19, ensure the Nylon Fastener faces outward.
2. Insert all screws loosely at first, then tighten them fully.
3. Tear off the protective cloth from the Nylon Fastener on the lower back of part 19, and press it flat.

Step 17

Connect part 04 to parts 07 and 09.

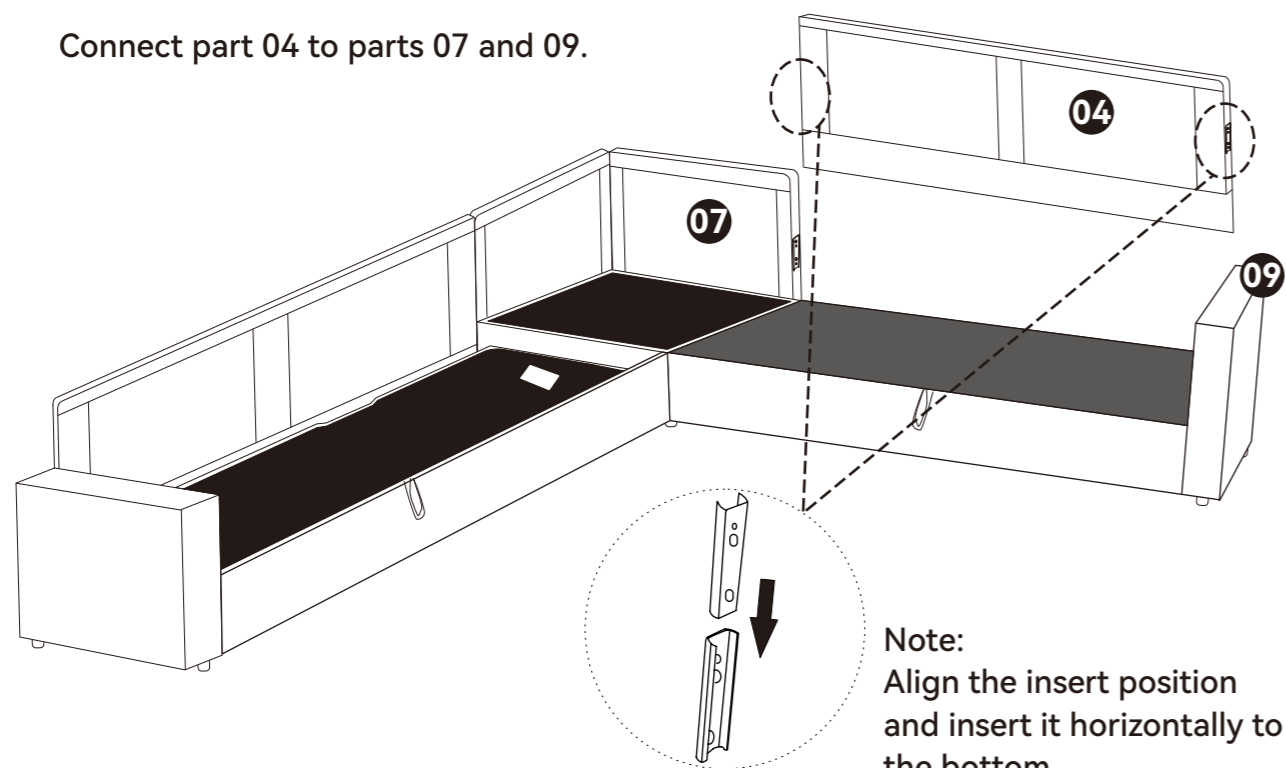

Note:
Align the insert position
and insert it horizontally to
the bottom.

Step 18

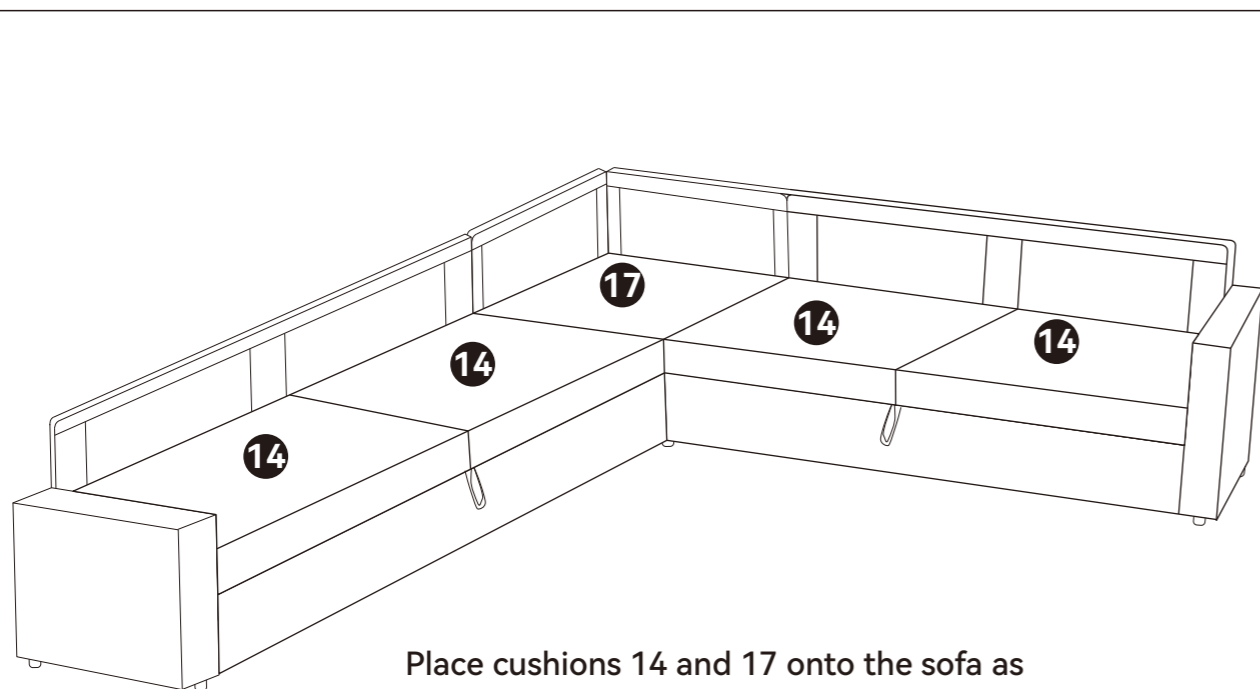

Place cushions 14 and 17 onto the sofa as
shown in the diagram.

Step 19

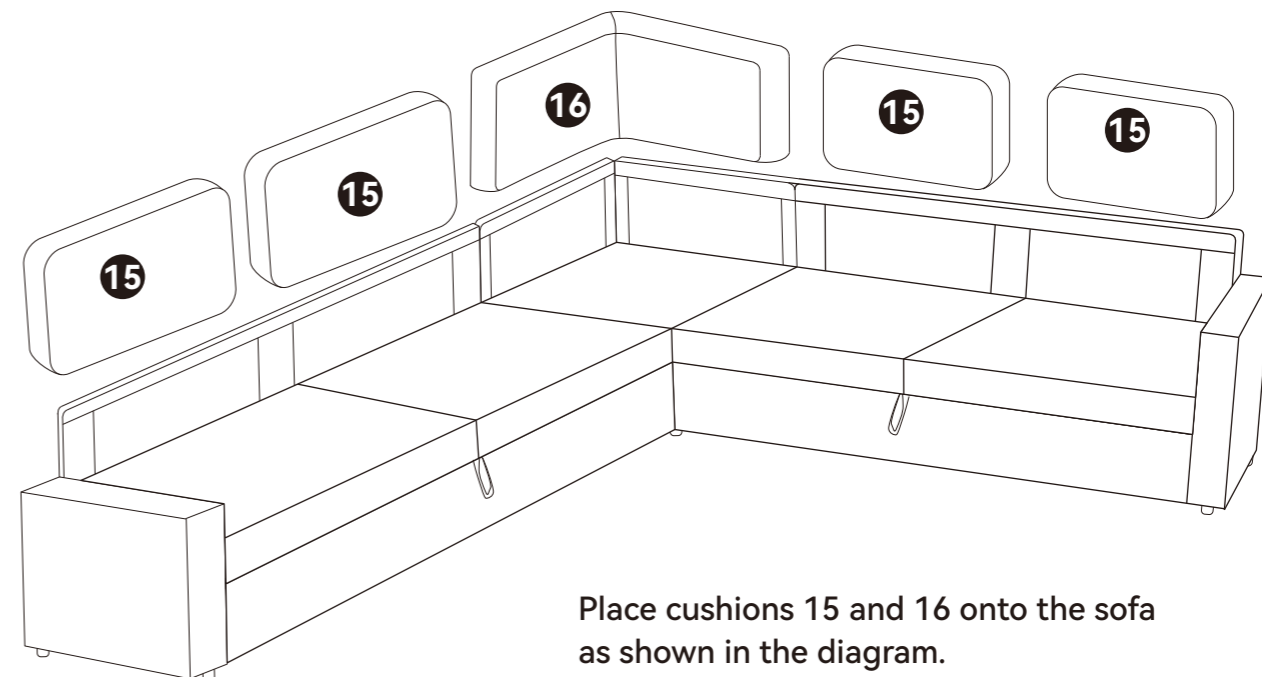

Place cushions 15 and 16 onto the sofa
as shown in the diagram.

Step 20

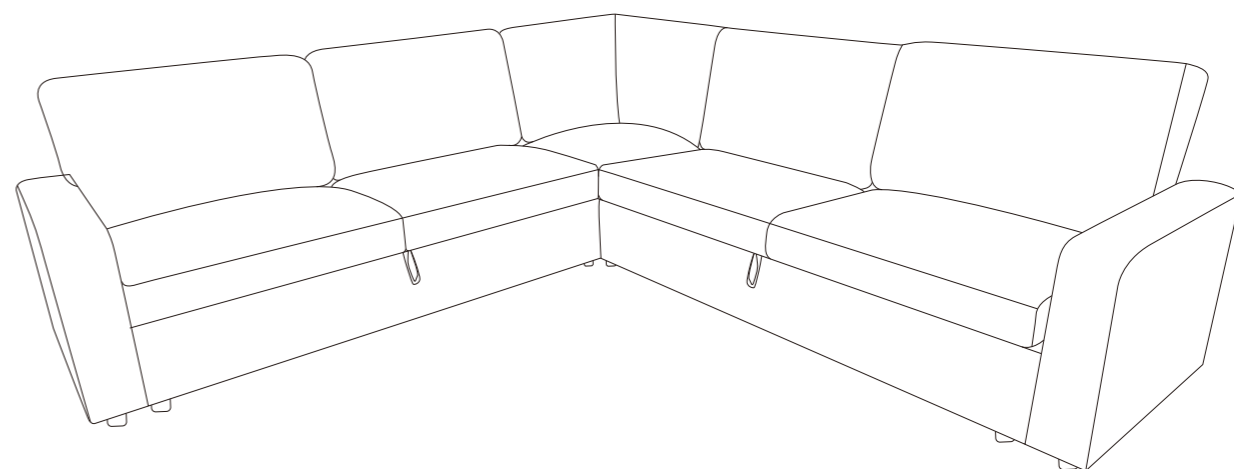

Assembly complete.

Step 21

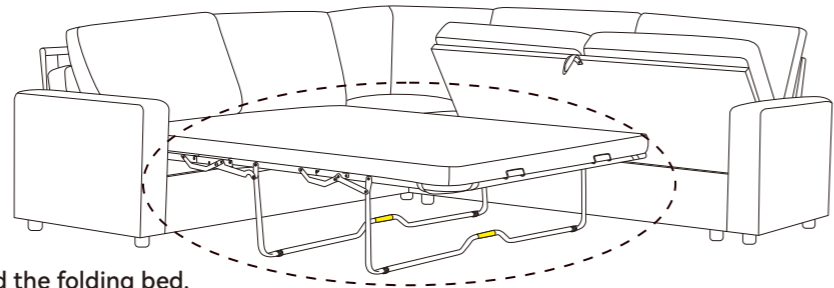

How to Use the Bed Frame:

Follow the illustrated steps to unfold the folding bed.

The seat cushions and backrests can be placed in the space behind. When not in use, fold the bed back in sequence.

Please pay attention to proper operation and safety while opening and closing the bed.

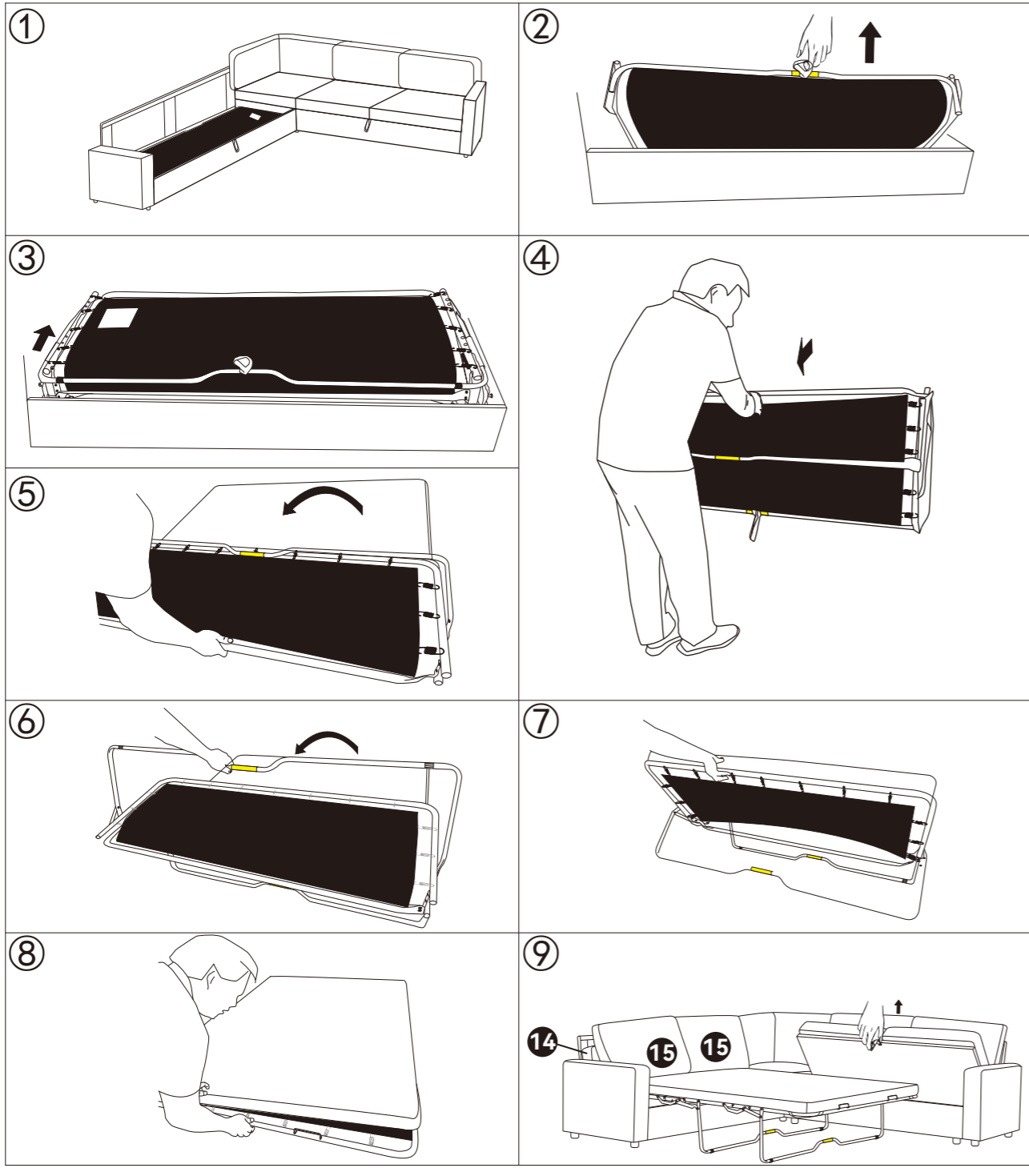

Maintenance

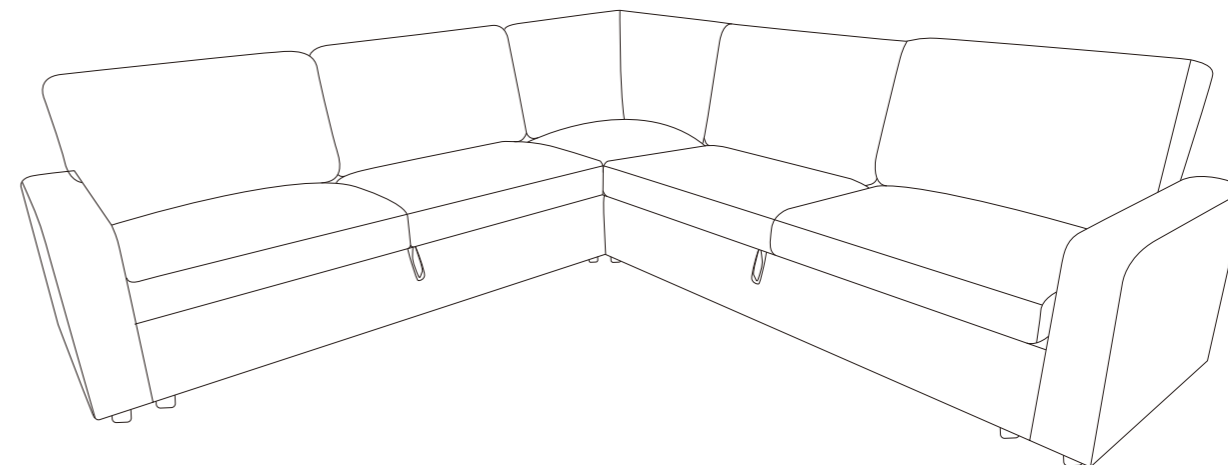

1. Avoid direct sunlight, preferably placed in a place that can avoid sunlight, or use translucent tulle curtains to block the sun.
2. Vacuum at least once a week, paying particular attention to removing dust accumulation between fabric structures.
3. Sofa cushions are turned over once a week to evenly distribute wear.
4. If stained, use a clean cloth dipped in water to wipe. In order to avoid leaving marks, it is best to wipe from the periphery of the stain. Velvet furniture should not be dipped in water and should use a dry cleaning agent.
5. All cloth covers and bushings should be dry-cleaned, not washed, not bleached.
6. If you find loose thread, do not tear it with your hand; it is best to cut the thread neatly with scissors.