

Installation Instructions

Ultima™ Selectronic® Battery Powered Toilet Flush Valve, Piston-Type

MODEL NUMBERS

606B.111 606B.121 606B.161 606B.721 606B.761

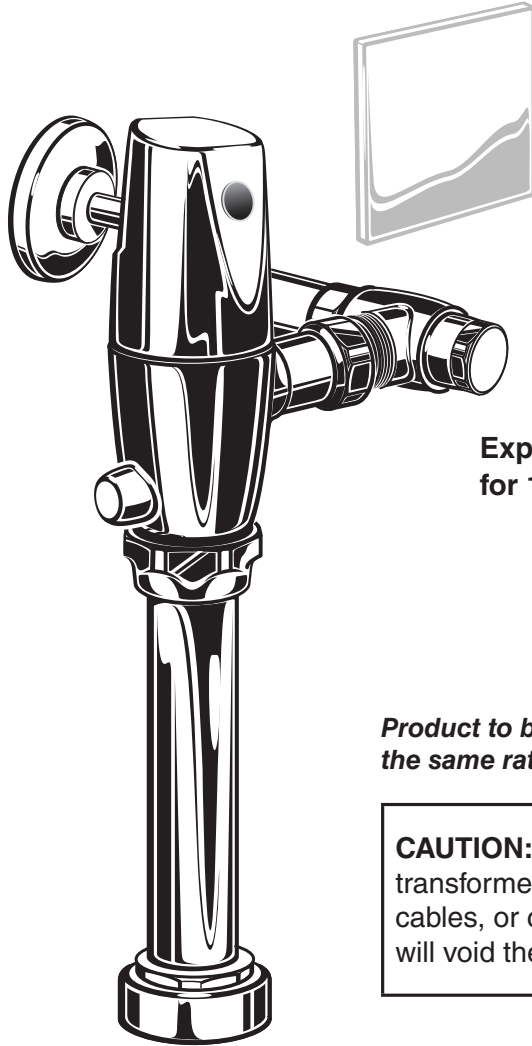

COVER PLATE
(Required for Front Installation Only)

Exposed Flush Valve
for 1-1/2" Top Spud Bowls

Product to be used with WaterSense Certified Fixture with the same rated flush volume.

CAUTION: Use only American Standard supplied transformers and cable sets. Using non-AS supplied cables, or cutting, splicing or modifying any components will void the warranty.

Certified to comply with ASME A112.19.2
© 2021 AS America, Inc.



American Standard

NOTE TO INSTALLER: Please give this manual to the customer after installation.

To learn more about American Standard Selectronic® Products visit our website at: www.americanstandard-us.com
or e-mail us at: CRTTEAM@americanstandard.com

For Parts, Service, Warranty or other Assistance,
please call (844) CRT-TEAM / (844) 278-8326 (In Canada: 1-800-387-0369)
(In Toronto Area only: 1-905-306-1093)

American Standard
CRT
Certified Response Technician

Thank you for selecting American-Standard...the benchmark of fine quality for over 100 years. To ensure that your installation proceeds smoothly--please read these instructions carefully before you begin.

UNPACKING

All American Standard Products Are Water Tested At Our Factory. Some Residual Water May Remain In The Valve During Shipping.

Remove the Flush Valve items from the carton. The illustration below shows all items after they have been removed from the carton. Some items may be packaged partially assembled to other items.

- | | |
|----------------------------------|------------------|
| 1. Installation Instructions | 8. Sweat Adapter |
| 2. Flush Valve Body Assembly | 9. Stop Valve |
| 3. Vacuum Breaker Tube | |
| 4. Spud Coupling Nut and Washers | |
| 5. Spud Flange | |
| 6. Wall Escutcheon | |
| 7. Cover Tube | |

CARE INSTRUCTIONS:

DO: CLEAN THE PRODUCT WITH CLEAR WATER, DRY WITH A SOFT COTTON FLANNEL CLOTH.

DO NOT: DO NOT CLEAN THE PRODUCT WITH SOAPS, ACID, POLISH, ABRASIVES, HARSH CLEANERS, OR A CLOTH WITH A COARSE SURFACE.

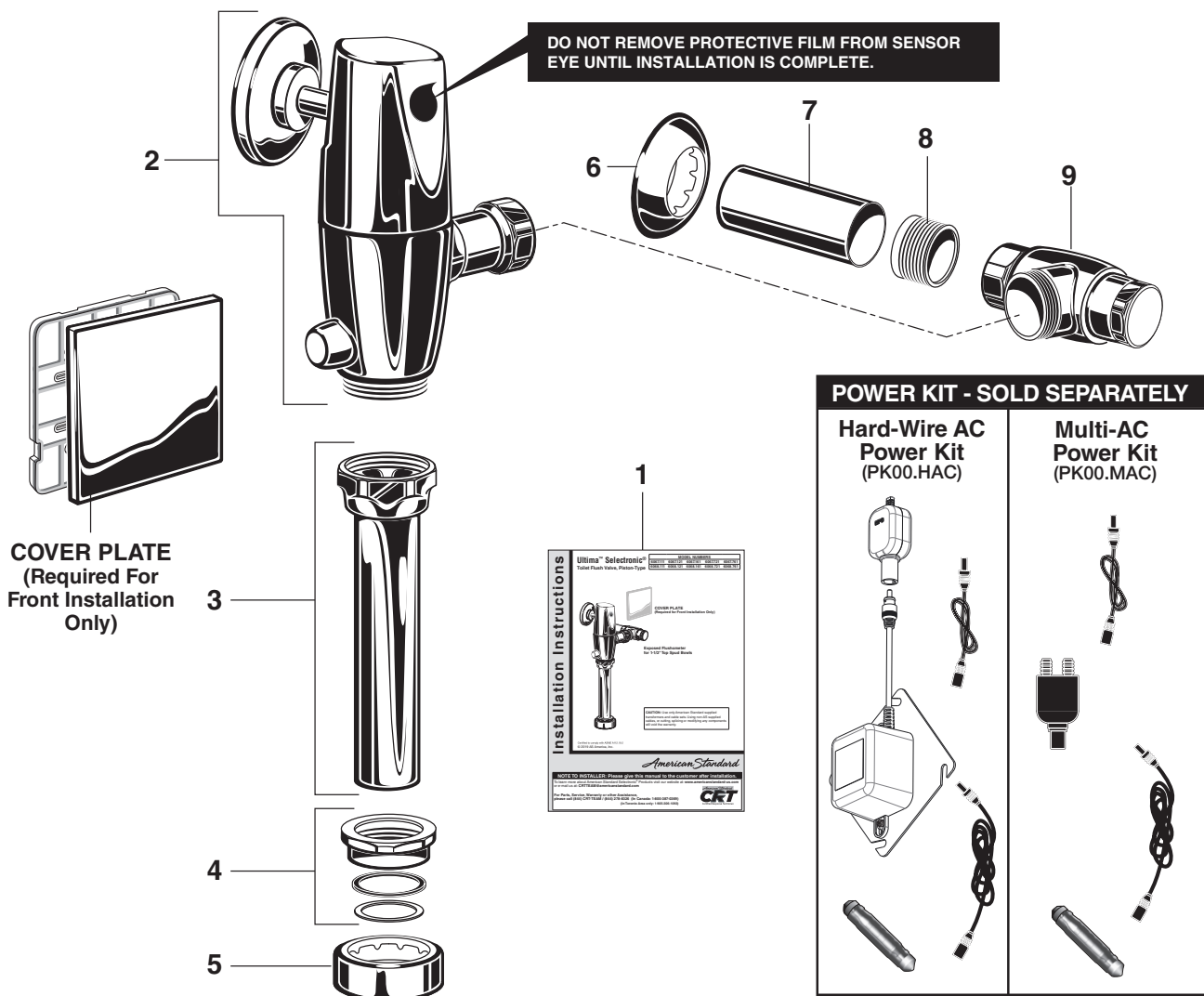

Roughing-in Dimensions *(Front Installation Shown)*

Right or Left Hand Installation

See (Section 5) for converting Flush Valve to Left Hand Installation.

GENERAL DESCRIPTION:

**SELECTRONIC® PROXIMITY TOILET
FLUSH VALVE for 1-1/2" Top Spud Fixtures**

CAUTION: Use only American Standard supplied transformers and cable sets. Using non-AS supplied cables, or cutting, splicing or modifying any components will void the warranty.

4" (102 mm) SQ. BOX DEVICE COVER (PLASTER RING).
3/4" (19 mm) HIGH **Hubbel-RACO #779** OR EQUAL
(BY CONTRACTOR).
*NOTE: INSTALL PLASTER RING SO THAT SCREW
HOLES ARE ON THE LEFT AND RIGHT SIDE OF BOX.*

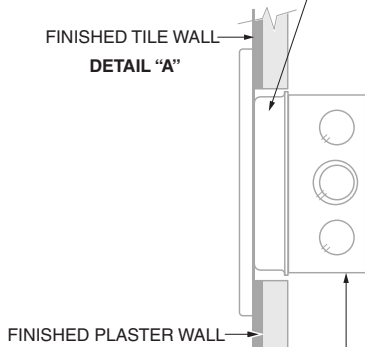

4" (102 mm) SQ. x 3-1/2" (89 mm) DEEP ELECTRICAL BOX
Hubbel-RACO #256 OR EQUAL (BY CONTRACTOR).

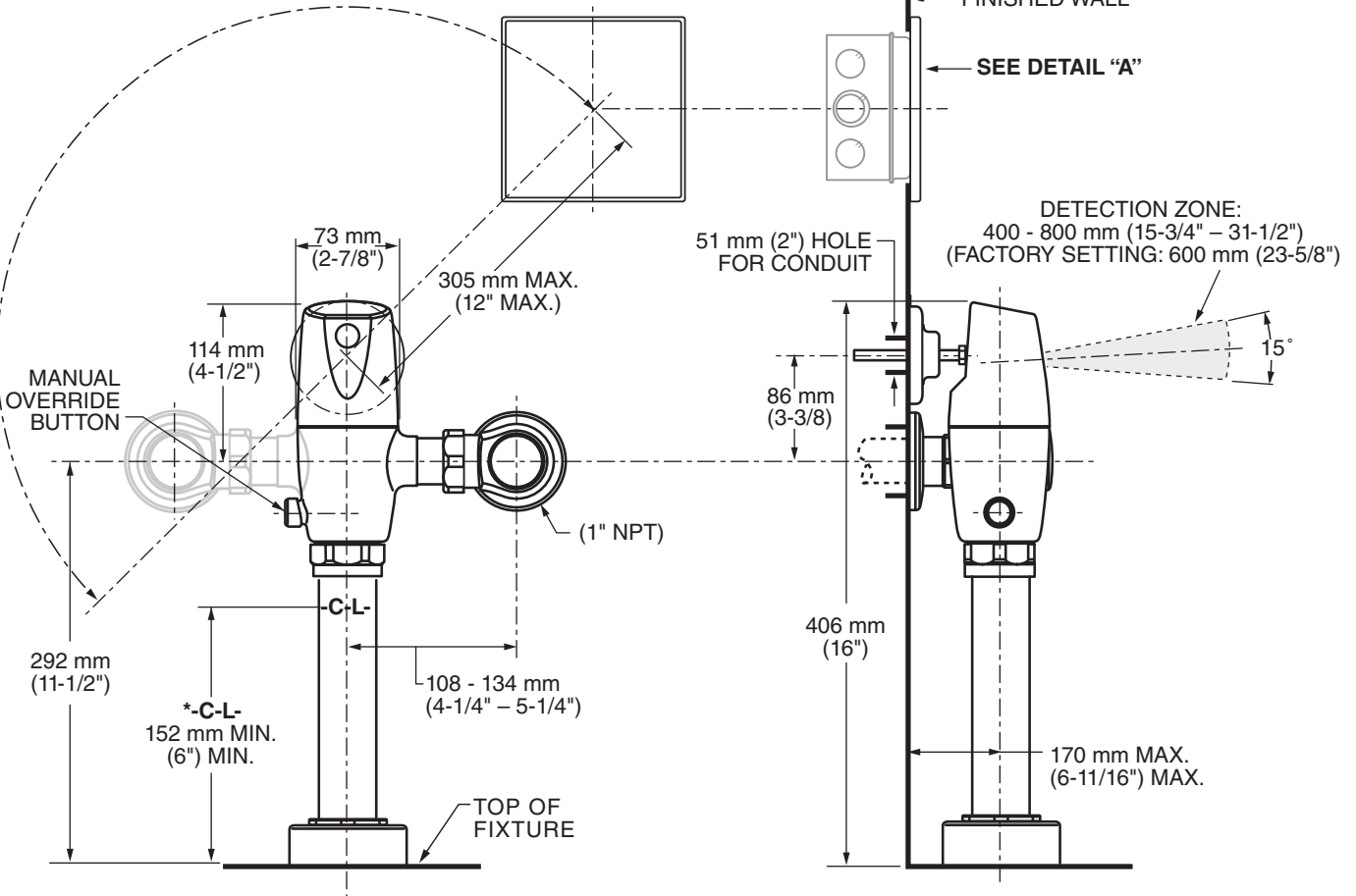

*Note: The Critical Line (-C-L-) on Vacuum Breaker must typically be 6" (152mm) above fixture. Consult Codes for details.

RECOMMENDED TOOLS; Fig. 2.

1. Teflon Tape
2. Flat Blade Screwdriver
3. Adjustable Wrench
4. Tape Measure
5. Hacksaw
6. Tubing Cutter
7. File
8. For Sweat Connection; Solder and Torch
9. 2.5 mm Hex Wrench
10. 1.5 mm Hex Wrench

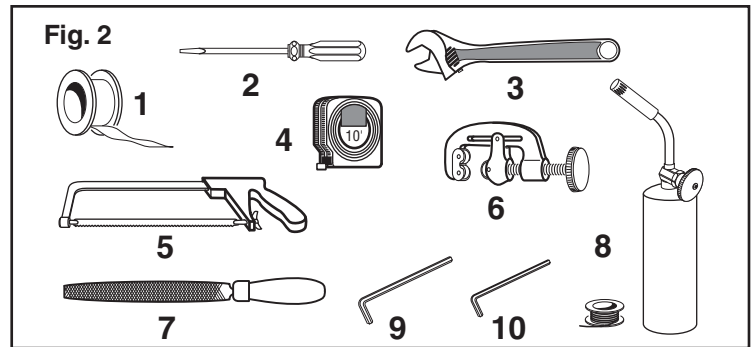

PRIOR TO INSTALLATION

Note: Prior to installing the Selectronic™ Flush Valve the following items must be installed.

1. Toilet
2. Drain line
3. Water supply line

IMPORTANT:

- All plumbing and electrical wiring should be installed in accordance with applicable codes and regulations.
- The use of water hammer arrestors is strongly recommended for commercial applications. All piping behind the walls should be properly secured and fastened.
- Water supply lines must be sized to provide an adequate volume of water for each fixture.

- Flush all water lines prior to operation. Dirt and debris can cause flush valve to run continuously.
- With the exception of Stop Valve Inlet, DO NOT use pipe sealant or plumbing grease on any valve component or coupling!
- Protect the chrome or special finish on the Flushometer. DO NOT USE toothed tools on finished surfaces to install or service these valves. Also see "Care and Cleaning" section of this manual.
- This product contains mechanical and/or electrical components that are subject to normal wear. These components should be checked on a regular basis and replaced as needed to maintain the valve's performance.

FLUSH VALVE INSTALLATION

1 INSTALL SWEAT ADAPTER; Fig. 3

CAUTION Turn water supplies off before beginning

Note: Install Optional Sweat Adapter (Supplied) for copper pipe supply line.

1. Measure the distance (A) from the finished wall to the center of the inlet spud on the fixture.
2. Cut the supply pipe 1-1/4" (A-B=C) shorter than the measurement taken in Step 1. File any rough edges off the end of the supply pipe.
3. Clean the end of the supply pipe. Push the threaded Adapter until it is seated against the internal stop. Sweat the Adapter to the pipe.

Fig.3

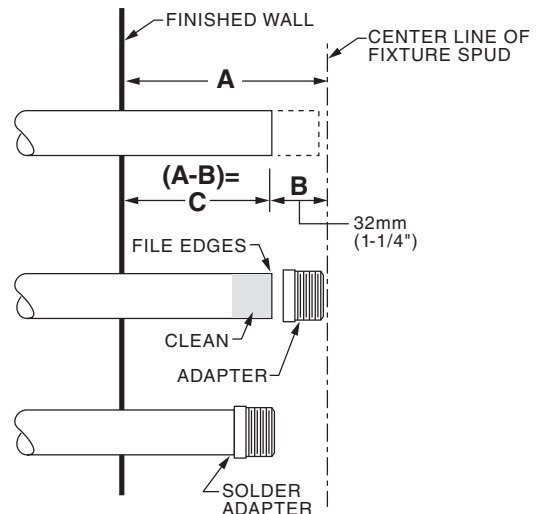

2 INSTALL COVER TUBE, WALL ESCUTCHEON and STOP VALVE; Fig. 4

1. Measure from finished wall to first thread of Adapter or threaded supply pipe (dimension "X"). Cut COVER TUBE (1) to length (X). Apply Teflon Tape to the threaded end of the Adapter or supply pipe.
2. Push WALL ESCUTCHEON (2) onto the COVER TUBE (1). Slide both onto the SUPPLY PIPE (3).
3. Push the COVER TUBE (1) in to expose the threads of the supply pipe. With a wrench, thread the STOP VALVE (4) onto the SUPPLY PIPE (3). Align and tighten.
4. Pull COVER TUBE (1) against STOP VALVE (4) and push WALL ESCUTCHEON (2) against finished wall.

Fig. 4

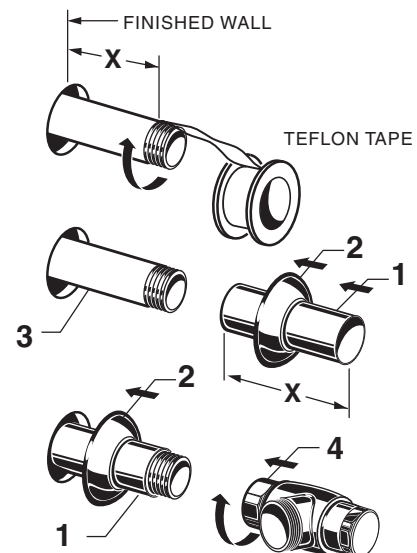

3 INSTALL VACUUM BREAKER TUBE; Fig. 5

1. Place the SPUD FLANGE (1) over the spud on the Fixture.
2. Place FRICTION WASHER (3) and SEAL WASHER (4) inside SPUD COUPLING NUT (2) and thread onto Spud. Do not tighten fully.
3. Insert the VACUUM BREAKER TUBE (5) into the SPUD COUPLING NUT (2) and push it down.

Note: If cutting VACUUM BREAKER TUBE (5) to size, note that Critical Line (C/L) on Vacuum Breaker must typically be 6" (152mm) above fixture. Consult Code for details.

Fig. 5

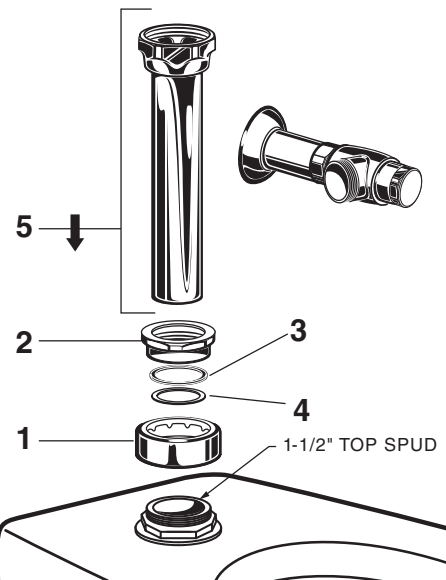

4 FLUSH OUT SUPPLY LINES; Fig. 6

1. Remove STOP VALVE COVER (1) from STOP VALVE (2).
2. Open STOP VALVE (2) with a flat blade screwdriver.
3. Turn on water supply to flush line of any debris or sediment.
4. Close STOP VALVE (2) and replace STOP VALVE COVER (1).

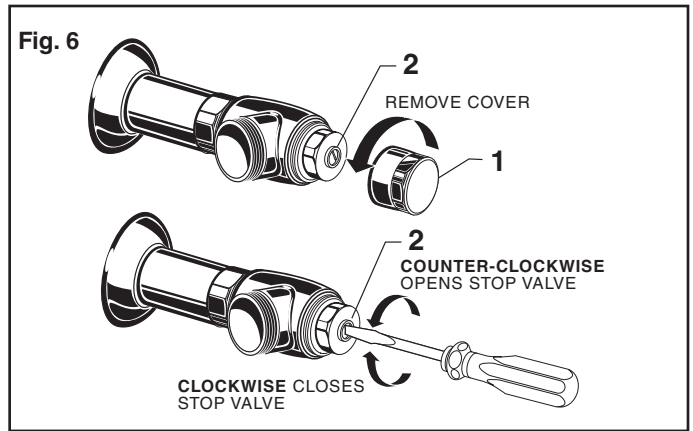

5 LEFT OR RIGHT HAND INSTALLATION; Fig. 7

The unit is shipped with the adjustable tailpiece on the right side. If needed, the orientation can be modified by following the steps below.

1. Loosen SET SCREW (1) with 2.5mm Hex Wrench (4) in back of FLUSH VALVE COVER (2).
2. Rotate FLUSH VALVE COVER (2) to the right and lift off.
3. Rotate FLUSH VALVE BODY (3) 180°
4. Replace COVER (2) and rotate until key engages. Tighten SET SCREW (1).

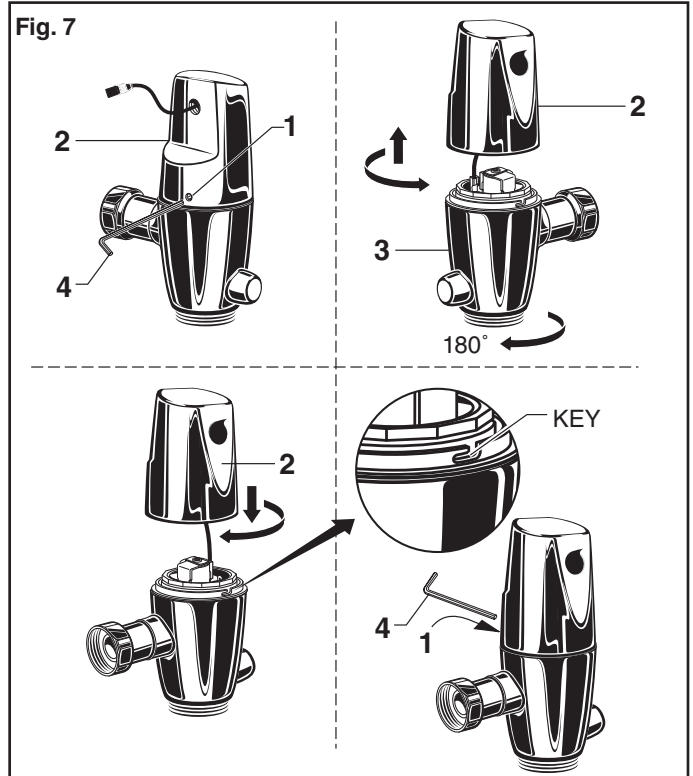

6 INSTALL FLUSH VALVE; Fig. 8, 8a

1. Insert ADJUSTABLE TAILPIECE (1) into the STOP VALVE (2). Lubricate the O-RING (3) with water if necessary. Lightly tighten COUPLING NUT (4). Fig. 8.

Important: Do not use lubricants (other than water) or any type of thread sealing paste or tape.

2. Align the FLUSH VALVE BODY (5) directly above the VACUUM BREAKER TUBE (7) and VACUUM BREAKER COUPLING NUT (6). Fig. 8a.

Note: There is a +13mm, -6mm (+1/2, -1/4) tolerance for the 121mm (4-3/4) dimension.

3. Pull the VACUUM BREAKER TUBE (7) up to meet the threaded FLUSH VALVE BODY (5), hand tighten the VACUUM BREAKER COUPLING NUT (6). Align all components of the flush valve assembly. Fig. 8a.

4. Lightly tighten the COUPLING NUT (4) connection first, then the VACUUM BREAKER COUPLING NUT (6) and finally the SPUD COUPLING NUT (8). Once aligned correctly, use a wrench to tighten couplings to make water tight connections. Fig. 8a.

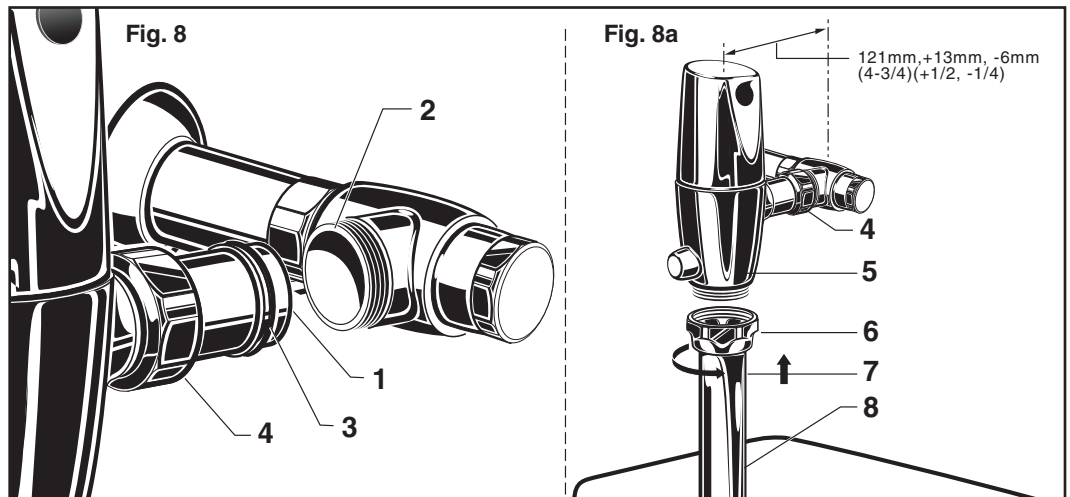

ELECTRICAL INSTALLATION

7 INSTALL POWER SUPPLY AND MAKE ELECTRICAL CONNECTIONS; Fig. 9 (remote and front installation)

CAUTION Ensure that the line power to bathroom is OFF prior to making connections.

1. Connect Black and White power connections to AC TRANSFORMER (1). Mount AC TRANSFORMER (1) onto ELECTRICAL BOX (2).
2. Connect the 10' EXTENSION CABLE (sold separately) to the CONVERTER (7).

Fig. 9

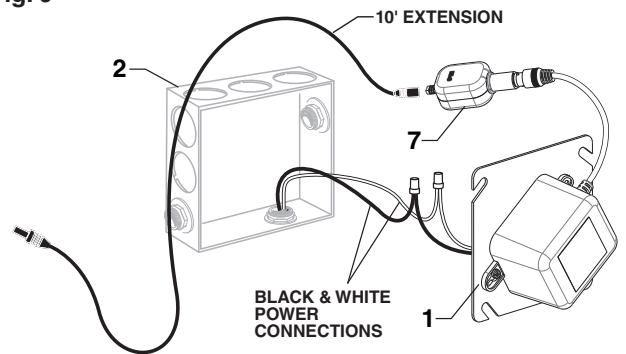

NOTE: AC Transformer must be installed on the outside of the Electrical Box.

8 INSTALL ELECTRICAL BOX (BY OTHERS); Fig. 10

FRONT INSTALLATION (with optional cover plate)

Note: The ELECTRICAL BOX (1) can be installed in any location along the marked arc.

Cut a 105 x 105 mm (4-1/8" x 4-1/8") opening in finished wall for ELECTRICAL BOX (1) (by others) and follow installation template provided in box. See Fig. 10.

REMOTE INSTALLATION FOR POWER SUPPLY

Mount a 4" x 4" x 2-1/2" (102 x 102 x 64 mm), ELECTRICAL BOX (1) (by others) within 10' from the installed flush valve. See Fig. 10.

8a INSTALL CONDUIT, ESCUTCHEON AND SENSOR CABLE; Fig. 10

1. Drill a 2" diameter hole (shown in Fig. 10) in the finished wall for the CONDUIT (2).
2. Pull 27" EXTENSION CABLE (3) through CONDUIT (2).
3. Slide ESCUTCHEON (1) onto CONDUIT (2).
4. For front installation, connect the 10' EXTENSION CABLE (4) to the 27" EXTENSION CABLE (3). Secure this connection with the CONNECTOR LOCKING DEVICE (5) and place inside electrical box.
5. Slide ESCUTCHEON (1) tight against finished wall and secure by tightening SET SCREW (6).

Fig.10 (TOP SPUD FIXTURE ILLUSTRATED)

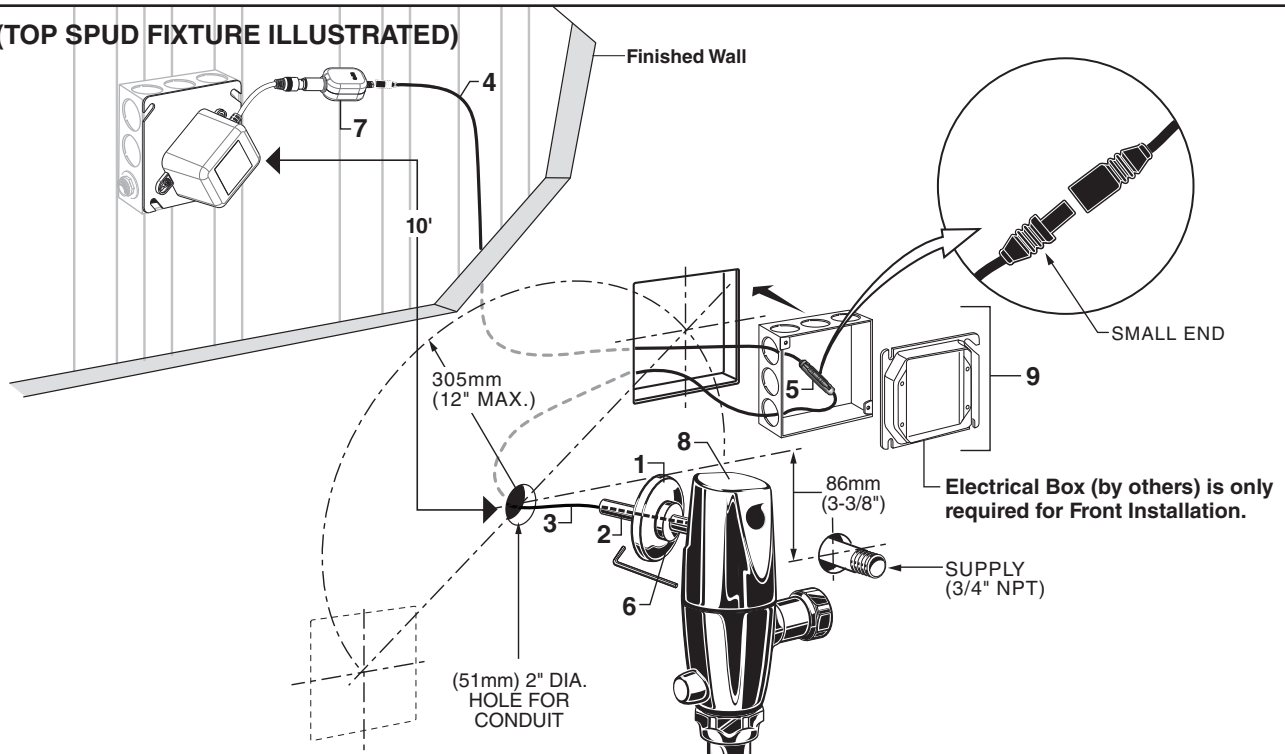

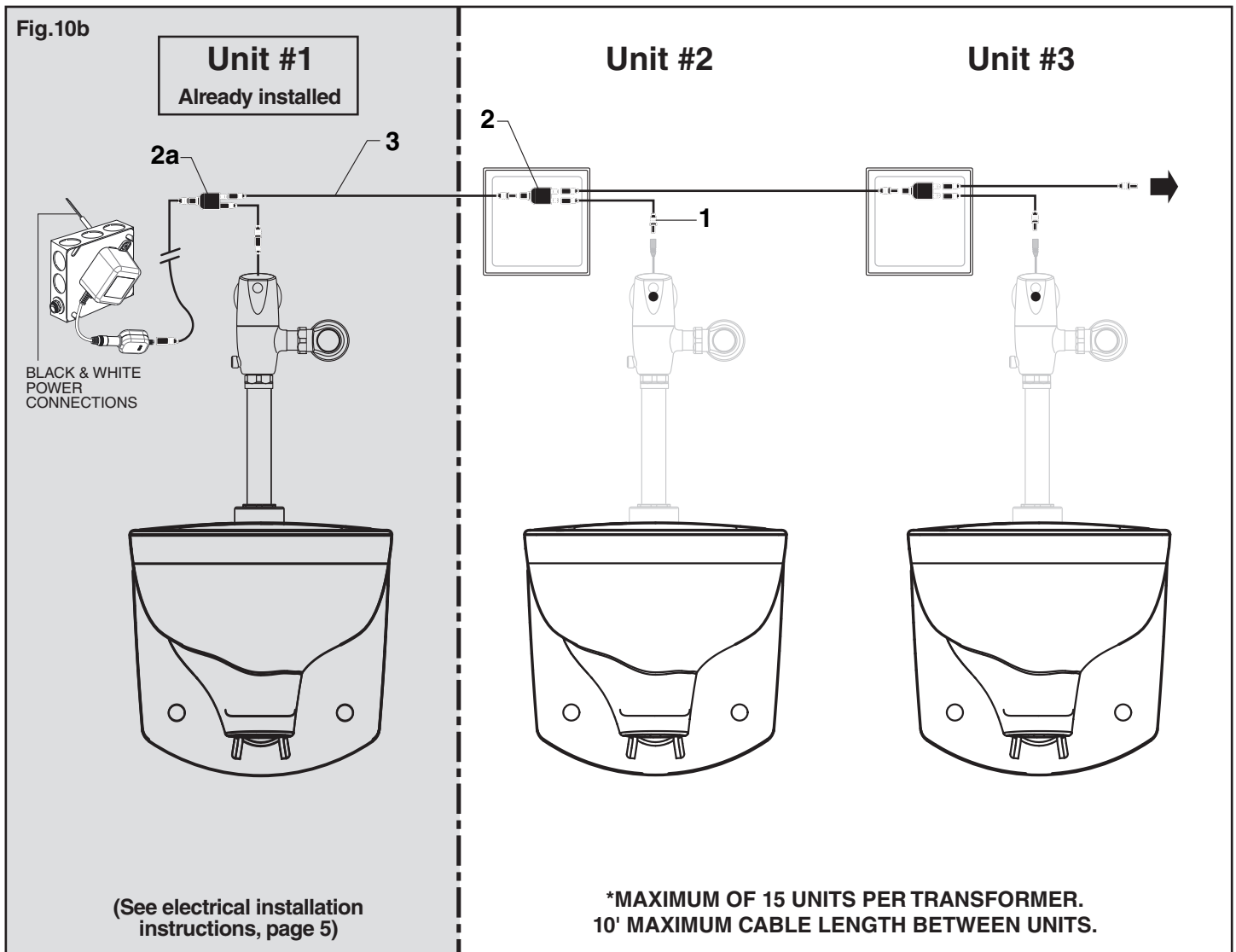

8b MULTI-AC VERSION (DAISY-CHAIN); Fig. 10b.

CAUTION Ensure that the line power to bathroom is OFF prior to making connections.

Important: All cover plates must be removed before beginning to make daisy-chain connections.

Note: For Unit #1 electrical instructions, refer to section #7 & #8a (page 5).

For subsequent Units, refer to section #7 (page 5), as well as instructions below..

1. Connect one end of the 27" EXTENSION CABLE (1) to one of the two available terminals on the one end of the Y-ADAPTER (2).
2. Take the 10' EXTENSION (3) and connect one end to the single terminal of Y-ADAPTER (2), and the other end to available terminal of the previous unit's Y-ADAPTER (2a).
3. Repeat process for each subsequent unit.
4. Place Y-ADAPTERS (2) into respective electrical box.
5. Reconnect the first unit's Y-ADAPTER (2a) to power supply once all daisy-chain unit connections have been made.

CAUTION: Use only American Standard supplied transformers and cable sets. Using non-AS supplied cables, or cutting, splicing or modifying any components will void the warranty.

9 COVER PLATE FRAME AND COVER PLATE INSTALLATION (front installation); Fig. 11

1. After power supply is remotely installed and wire connections are completed, install the COVER PLATE FRAME (1) onto the ELECTRICAL BOX (2).
2. Install the two tabs on the back side of the COVER PLATE (3) into the two Slots located on the top edge of the COVER PLATE FRAME (1). Push on bottom until it snaps into place.

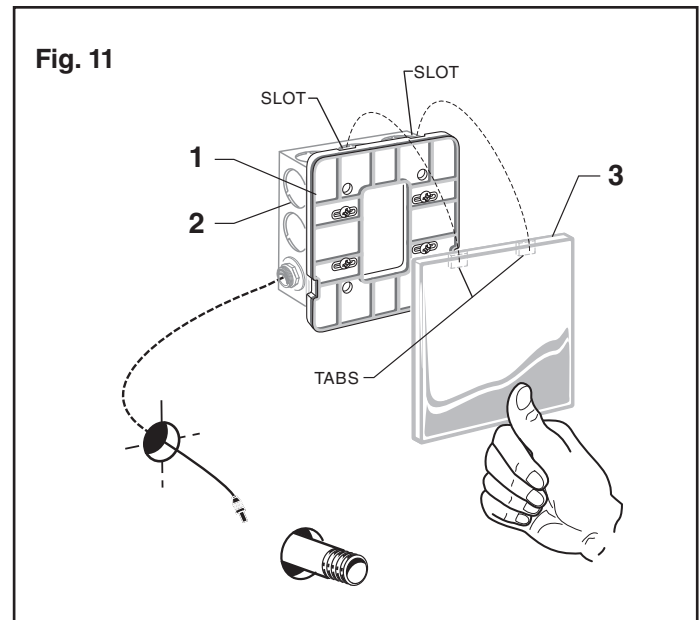

CAUTION: Use only American Standard supplied transformers and cable sets. Using non-AS supplied cables, or cutting, splicing or modifying any components will void the warranty.

MAINTENANCE

A ADJUST STOP VALVE; Fig. 12

IMPORTANT: To avoid overflowing, the STOP VALVE (3) must never be opened to the point where the flow from the valve exceeds the draining ability of the fixture.

1. After installation is complete, peel off the PROTECTIVE FILM (1) from the sensor. Standing to one side, block the sensor with your hand for 10 seconds.

Remove your hand and listen for audible “click” from within the valve.

2. Remove STOP VALVE COVER (2) from STOP VALVE (3). Turn on water supply 1/4 turn to 1/2 turn (CCW) and test for leaks.

Note: Unit may flush for approximately 5 to 10 sec. when water is first turned on. If flow persists, turn water off and repeat step #1 above.

3. Actuate the FLUSH VALVE:
 - A) Cover sensor with hand for 10 seconds.

NOTE: Stand outside of sensor detection area.

- B) Remove hand from sensor detection area; unit will flush in approximately 3 seconds.

4. Adjust STOP VALVE (3) after each flush until the stated flush volume is achieved, no splashing occurs and the fixture is properly cleansed.

5. When adjustment is complete, replace STOP VALVE COVER (2) and tighten to ensure vandal-resistance.

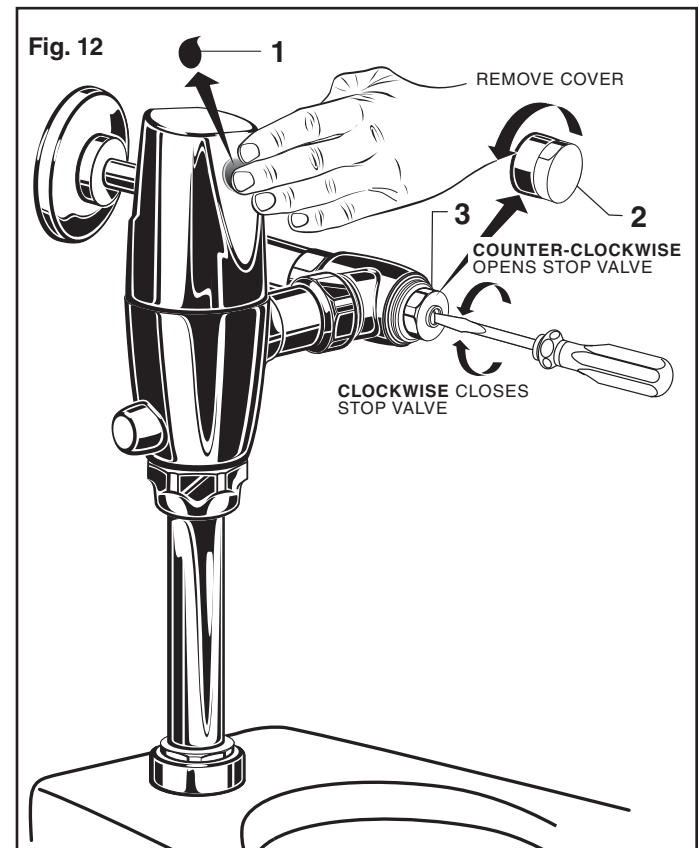

B SET DETECTION RANGE (if Required); Fig. 13 & 14

Note: *The detection distance is preset and ideal for most installations. Should an adjustment be required, follow the steps below.*

1. To remove the COVER PLATE (1), insert WIRE KEY (2) (supplied) into the two holes located at the bottom of the COVER PLATE (1). Push the WIRE KEY (2) up until it releases the bottom clips. Pull the bottom edge away and lift the COVER PLATE (1) off. **Fig. 13.**
2. Remove the connections from the CONNECTOR LOCKING DEVICE (5). Disconnect the 27" EXTENSION CABLE (3) from the 10' EXTENSION CABLE (4), and reconnect.

Note: *You have 5 seconds to begin entering the program code after power connection is made.*

3. While the SENSOR CONTROL LED (1) is blinking slowly, place your hand 1 to 2 in. (30-50 mm.) in front of the sensor. **Fig. 14.**
4. When the LED (1) stops blinking and stays "ON", move your hand to the desired position from sensor and hold in place until the LED (1) begins to blink again.

Note: *Detection Zone is 400 - 800 mm (15-3/4"x 31-1/2"). (Factory Setting: 400 mm (15-3/4"))*

5. Once the SENSOR CONTROL LED (1) begins to blink again, remove your hand from the detection zone. When the flashing stops, the detection distance is set.
6. Actuate the FLUSH VALVE:
 - A) Cover sensor with hand for 10 seconds.

NOTE: Stand outside of sensor detection area.

 - B) Remove hand from detection area; unit will flush in approximately 3 seconds.

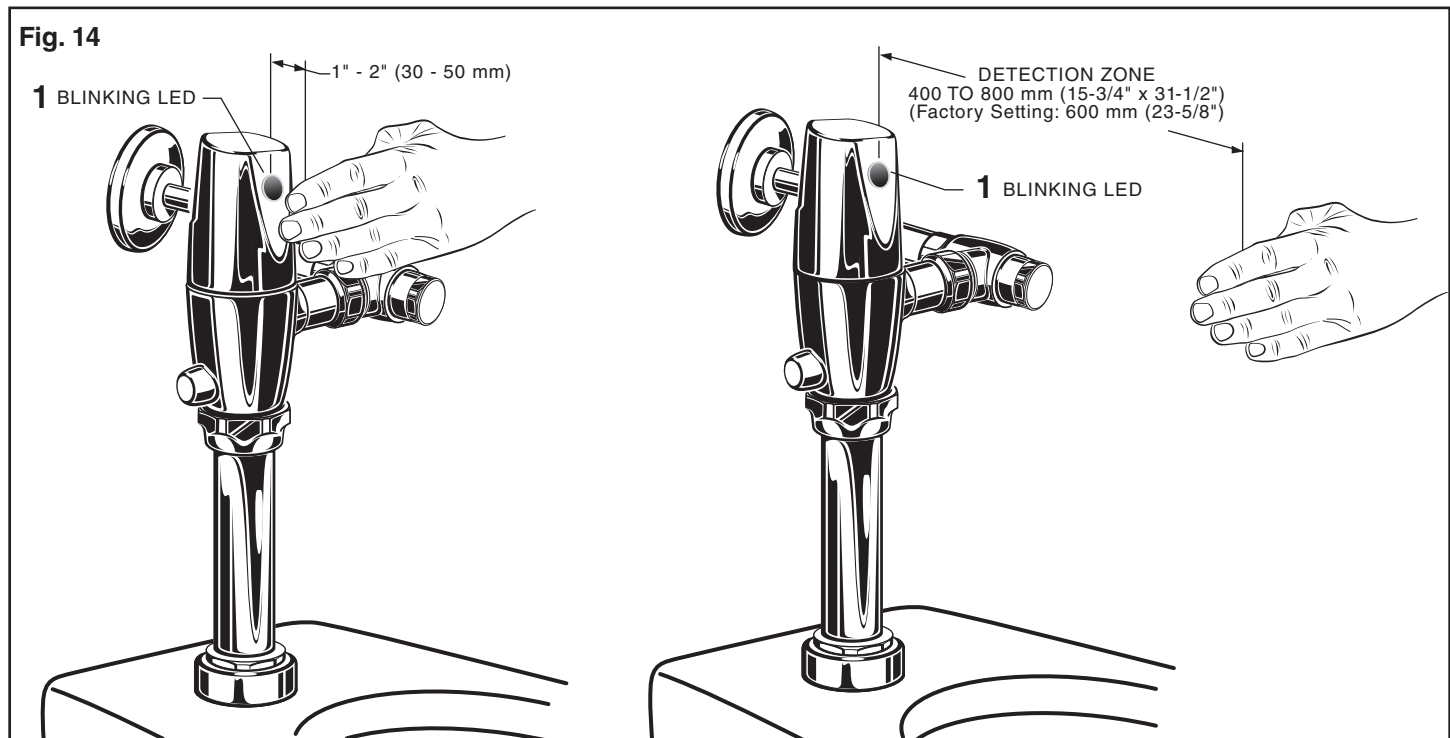
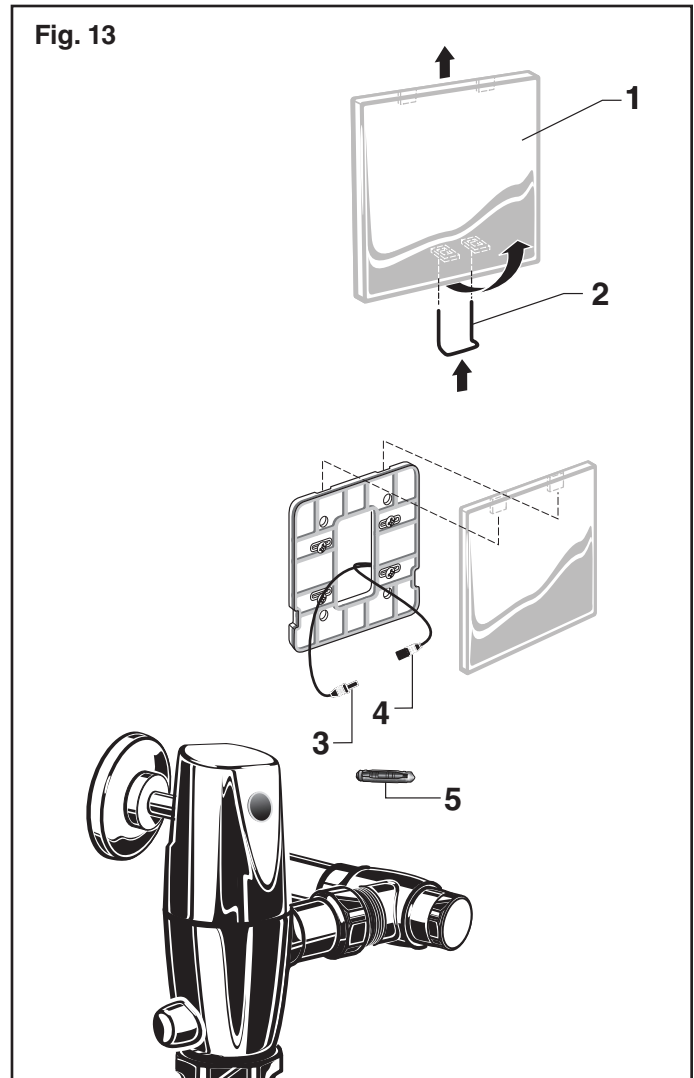

TROUBLESHOOTING FLOW CHARTS

UNIT DOES NOT FUNCTION

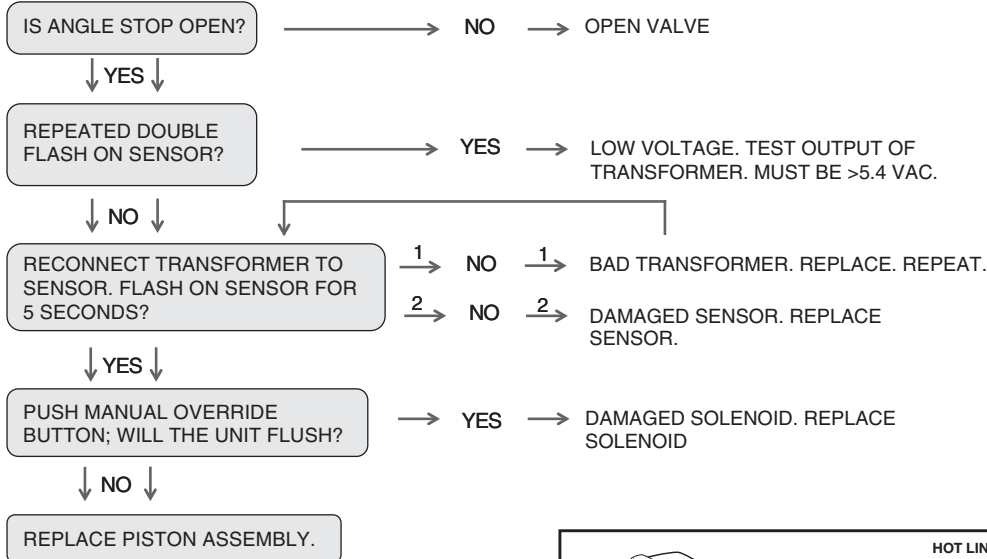

UNIT IS CONTINUOUSLY FLUSHING

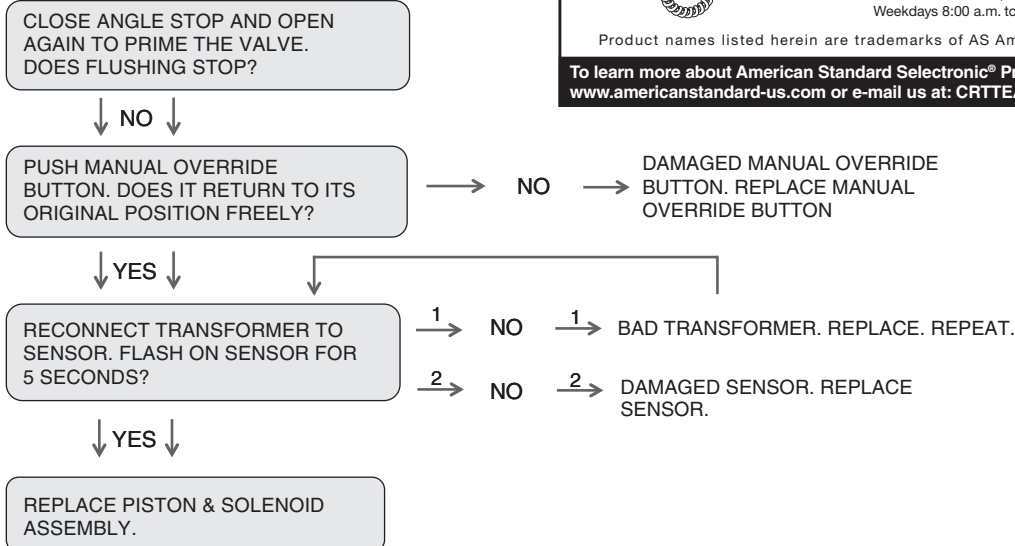

UNIT WILL ONLY FLUSH MANUALLY

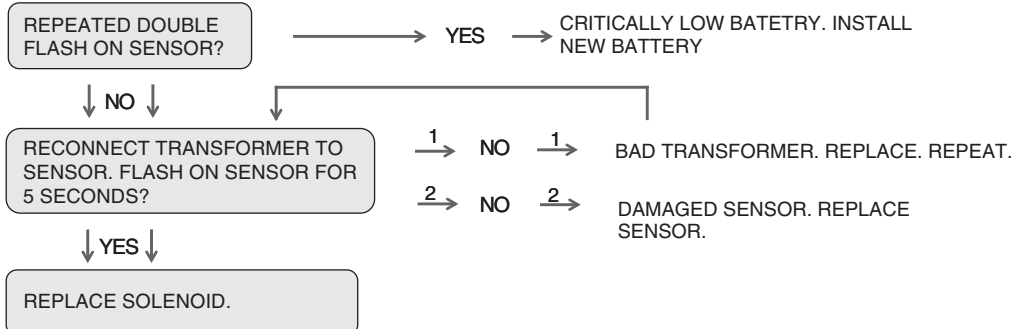



HOT LINE FOR HELP

For toll-free information and answers to your questions, call:
 (844) CRT-TEAM / (844) 278-8326
 Mon.– Fri. 8:00 a.m. to 8:00 p.m. EST Sat. 10:00 a.m. to 4:00 p.m. EST
 IN MEXICO 01-800-839-1200
 IN CANADA 1-800-387-0369 (TORONTO 1-905-306-1093)
 Weekdays 8:00 a.m. to 7:00 p.m. EST

Product names listed herein are trademarks of AS America, Inc. ©2021

To learn more about American Standard Selectronic® Products visit our website at:
www.americanstandard-us.com or e-mail us at: CRTTEAM@lixiamerica.com

American Standard

Ultima™ Selectronic® Battery Powered Toilet Flush Valve, Piston-Type

MODEL NUMBERS				
606B.111	606B.121	606B.161	606B.721	606B.761

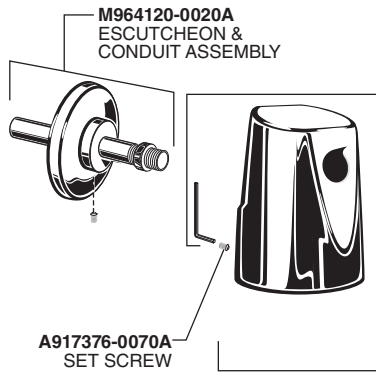

M964120-0020A
ESCUTCHEON &
CONDUIT ASSEMBLY

A917376-0070A
SET SCREW

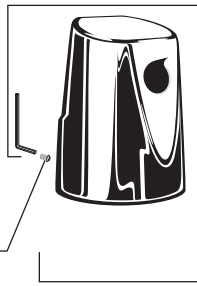

M970695-0020A
COVER ASSEMBLY
DOES NOT INCLUDE SENSOR



- M970682-0071100A
SENSOR ASSEMBLY
(1.1gpf)
- M970682-0071280A
SENSOR ASSEMBLY
(1.28 gpf)
- M970682-0071600A
SENSOR ASSEMBLY
(1.6 gpf)
- M970682-0075000A
SENSOR ASSEMBLY
(1.28/1.1gpf)
- M970682-0074000A
SENSOR ASSEMBLY
(1.6/1.1gpf)

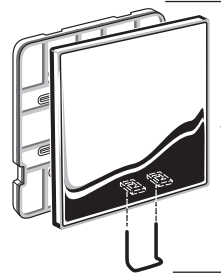

M964015-0020A
COVER PLATE
ASSEMBLY

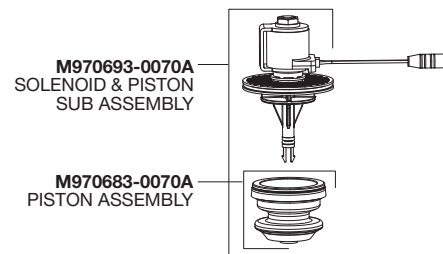

M970693-0070A
SOLENOID & PISTON
SUB ASSEMBLY

M970683-0070A
PISTON ASSEMBLY

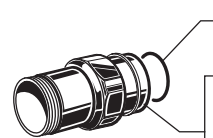

A912809-0070A
O-RING

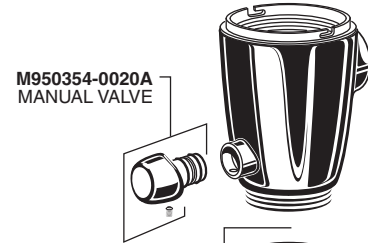

M950354-0020A
MANUAL VALVE



M964945-0020A
ADJUSTABLE TAILPIECE
(4-1/4" to 5-1/4" Rough-in)

OPTIONAL ADJUSTABLE TAILPIECE
(Purchased Separately)

- M962836-0020A (8-1/4" to 9-1/4" Rough-in)
- M962835-0020A (7-1/4" to 8-1/4" Rough-in)
- M962834-0020A (6-1/4" to 7-1/4" Rough-in)
- M962833-0020A (5-1/4" to 6-1/4" Rough-in)

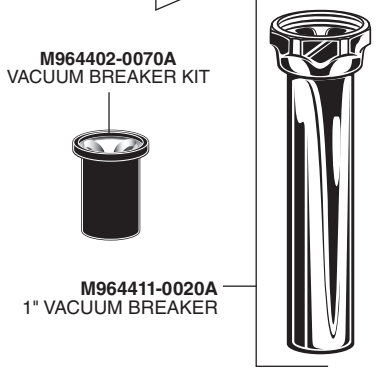

M964402-0070A
VACUUM BREAKER KIT

M964411-0020A
1" VACUUM BREAKER

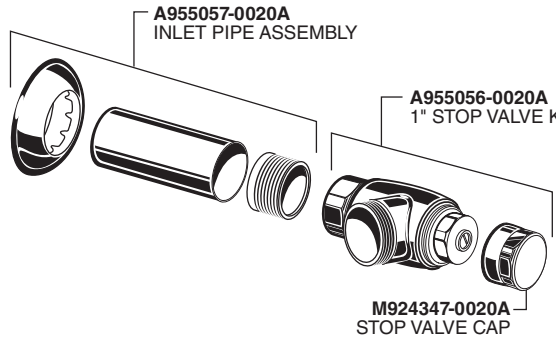

A955057-0020A
INLET PIPE ASSEMBLY

A955056-0020A
1" STOP VALVE KIT

M924347-0020A
STOP VALVE CAP

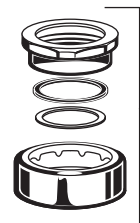

M952269-0020A
ESCUTCHEON KIT

POWER KITS

Hard-Wired AC

M950360-0070A
CONNECTOR
LOCKING DEVICE

M950511-0070A
10' EXTENSION
CABLE

M950527-0070A
POWER SUPPLY

Multi-AC

M950512-0070A
Y-ADAPTER

M950511-0070A
10' EXTENSION

HOT LINE FOR HELP

For toll-free information and answers to your questions, call:

(844) CRT-TEAM / (844) 278-8326

Mon. - Fri. 8:00 a.m. to 8:00 p.m. EST Sat. 10:00 a.m. to 4:00 p.m. EST

IN MEXICO 01-800-839-1200

IN CANADA 1-800-387-0369 (TORONTO 1-905-306-1093)

Weekdays 8:00 a.m. to 7:00 p.m. EST

Product names listed herein are trademarks of AS America, Inc. ©2021

To learn more about American Standard Selectronic® Products visit our website at:
www.americanstandard-us.com or e-mail us at: CRTEAM@lixilamericas.com

PART OF **LIXIL**