

WARNING

- * Switch off the main electrical supply from the main fuse box / circuit breaker before installation.
- * Inspect item carefully before attempting to install.
- * If there is any damages or obvious defects, do not install.
- * Item may not be returned once it has been installed.

CARE AND MAINTENANCE













- * To clean the outside of the fixture, use a dry or slightly dampened clean cloth (use clean water, never a solvent) to wipe the surface of the fixture.
- * To clean the inside of the fixture, first disconnect power to the fixture by turning off the circuit breaker or by removing the fuse at the fuse box. Next, use a dry or slightly dampened clean cloth (use clean water, never a solvent) to wipe the interior surface of the fixture.
- * Do not use any cleaners with chemical, solvents or harsh abrasives. Use only a dry soft cloth to dust or wipe carefully.

Product Dimension:16"L x 16"W x 10"H

NOTICE& IMPORTANT SAFETY INSTRUCTIONS

- ** WE RECOMMEND INSTALLATION OF THIS LIGHTING FIXTURE BE DONE BY A LICENSED ELECTRICIAN **
- * Please make sure that you have all parts indicated before you begin assembly of this item
- * This item should be assembled on a soft surface to prevent scratching the finish during assembly
- * To reduce the risk of fire, electrical shock or injury to persons or property, please follow the guideline below for safe use and installation
- *The external flexible cable or cord of this lamp cannot be replaced
If the cord is damaged, the lamp shall be destroyed

Part List and Hardware List

PIECE	DESCRIPTION	PICTURE	QUANTITY	PIECE	DESCRIPTION	PICTURE	QUANTITY
A	Mounting Plate		1X	G	Shade		1X
B	Wire Nut		3X	H	Threaded Stem with nuts		1X
C	Mounting Screw		2X	I	Round plate		2X
D	Canopy +Socket		1X	J	Diffuser		1X
E	Canopy Nut		2X	K	Hexagon nut		2X
F	BULB		3X	L	Finial		1X

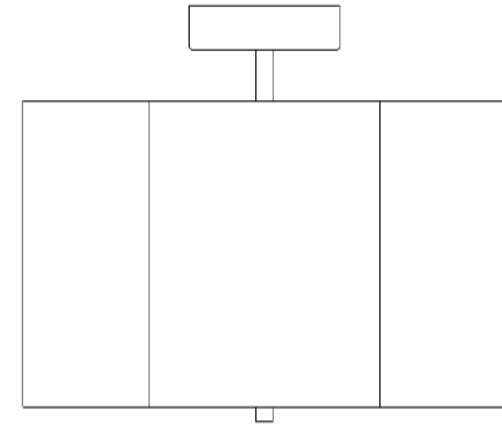

PREPARATION

- * Before beginning assembly of product, make sure all parts are present. Compare parts with package contents list and hardware contents list.
- * If any part is missing or damaged, do not attempt to assemble the product.
- * Estimated Assembly Time: 20 minutes.
- * Tools Required for Assembly (not included): Screwdriver, Junction box

NOTE: PLEASE USE TYPE "A" BULB MAX 40-WATT OR CFL BULB MAX 13-WATT OR LED MAX 9-WATT, THERE ARE 3PCS 4W LED BULBS IN BOX.

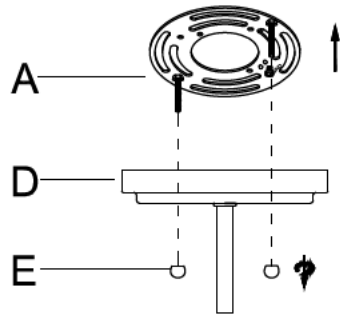

Step 1: Unpack all parts from cartons carefully. Separate the Mounting Plate (A) from the Canopy (D) by removing the Canopy Nut (E) anti-clockwise.

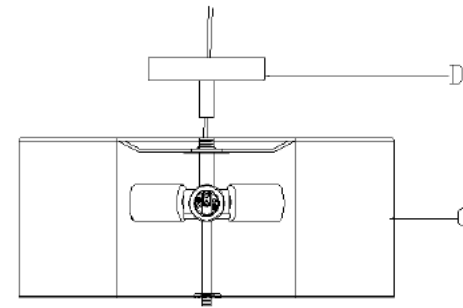

Step 2: Insert the fixture wires through the Canopy (D). Rotate the Canopy (D) clockwise till tight.

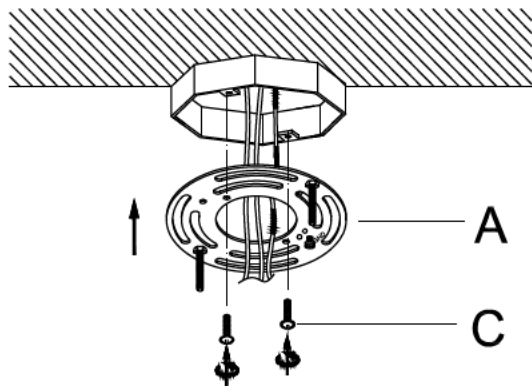

Step 3: Insert the J-box wires through the center opening of Mounting Plate (A). Attach the Mounting Plate (A) onto the J-box and secure it by turning the 2 Mounting Screws (C) clockwise until tight.

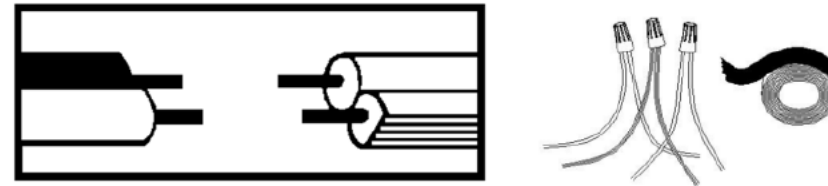

Step 4: Wire connection

Connect fixture neutral wire (ribbed) to the outlet box neutral wire (usually white) using a wire nut. Connect fixture hot wire (smooth with markings) to the outlet box hot wire (usually black) using a wire nut.

CAUTION: Do not reverse the hot and neutral connections

Grounding Instructions:

Wrap ground wire from outlet box around green ground screw on mounting bracket, no less than 2" from wire end. Tighten ground screw. If fixture is supplied with a ground wire, connect to outlet ground wire with a wire nut.

PREPARATION

- * Before beginning assembly of product, make sure all parts are present. Compare parts with package contents list and hardware contents list.
- * If any part is missing or damaged, do not attempt to assemble the product.
- * Estimated Assembly Time: 20 minutes.
- * Tools Required for Assembly (not included): Screwdriver, Junction box

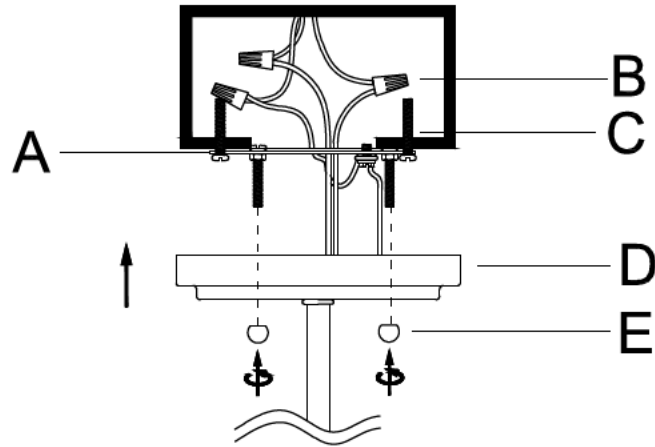

Step 5: Attach the Canopy(D) to the Mounting Plate (A) and fix it by turning the Canopy Nut (E) clockwise.

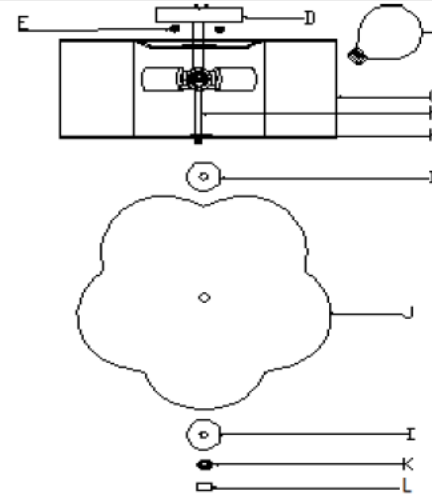

Step 6: Insert the Bulbs (F) into the Socket as diagram. Place the Round plate(I) onto the Threaded Stem with Nuts (H). And place the Diffuser (J) and the Round plate (I) into the Threaded Stem with Nuts (H) underneath the socket as diagram. Fix the Diffuser(J) in place by turning the Nut (K) clockwise till tight. Then turn the Finial (L) clockwise till tight.

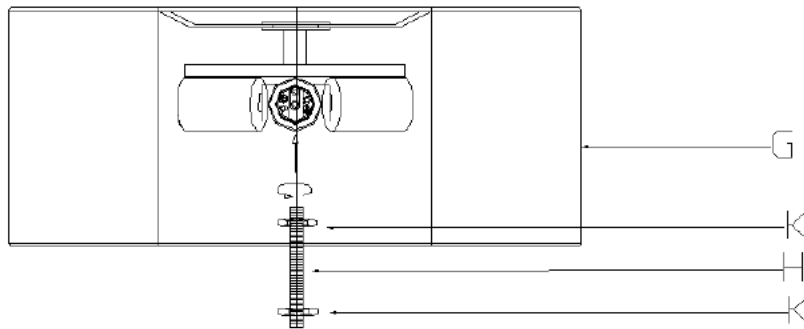

Step 7: Screw the Threaded Stem with Nuts (H) into the threaded portion of of the tube underneath the socket as diagram.