

CAUTION:When tightening the screws , tighten sequentially. Do not tighten any screws fully and then towards the next one.when every part is OK, then tighten all the screws.

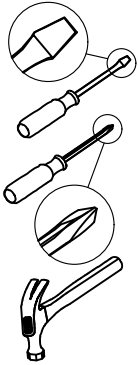

PLEASE BE CAREFUL DO NOT DAMAGE THE HOLE POSITION WHEN YOU USE POWER TOOLS !

Before You Start



- ✓ Read through each step carefully and follow the proper order
- ✓ Separate and count all your parts and hardware
- ✓ Give yourself enough room for the assembly process
- ✓ Have the following tools: Flat Head Screwdriver, #2 Phillips Head Screwdriver and Hammer
- ✓ Caution: If using a power drill or power screwdriver for screwing, please be aware of to slow down and stop when screw is tight. Failure to do so may result in stripping the screw. (Assembly speed can be increased by using electric screwdriver)

Helpful Hints

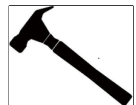
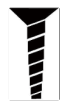

PEOPLE NEEDED FOR ASSEMBLY: 1-2

- Open your item in the area you plan to keep it to avoid excessive heavy lifting.
- Identify, sort and count the parts before attempting assembly.
- Compression dowels are lightly tapped in with a hammer.
- Slides are labeled with an **R** (right) and **L** (left) for proper placement.
- Make sure to always face the point on the top of the Cam Lock towards the outer edge.
- If there is a back panel in the package, please install it to make sure your unit is complete and sturdy.
- Please fix all the screws provided for the back panel which can enhance product stability. If it is difficult to fix it when tightening, it can be fixed with the help of a hammer and then tightened.
- Do NOT use harsh chemicals or abrasive cleaners on this item.
- Never push, pull, or drag your furniture.

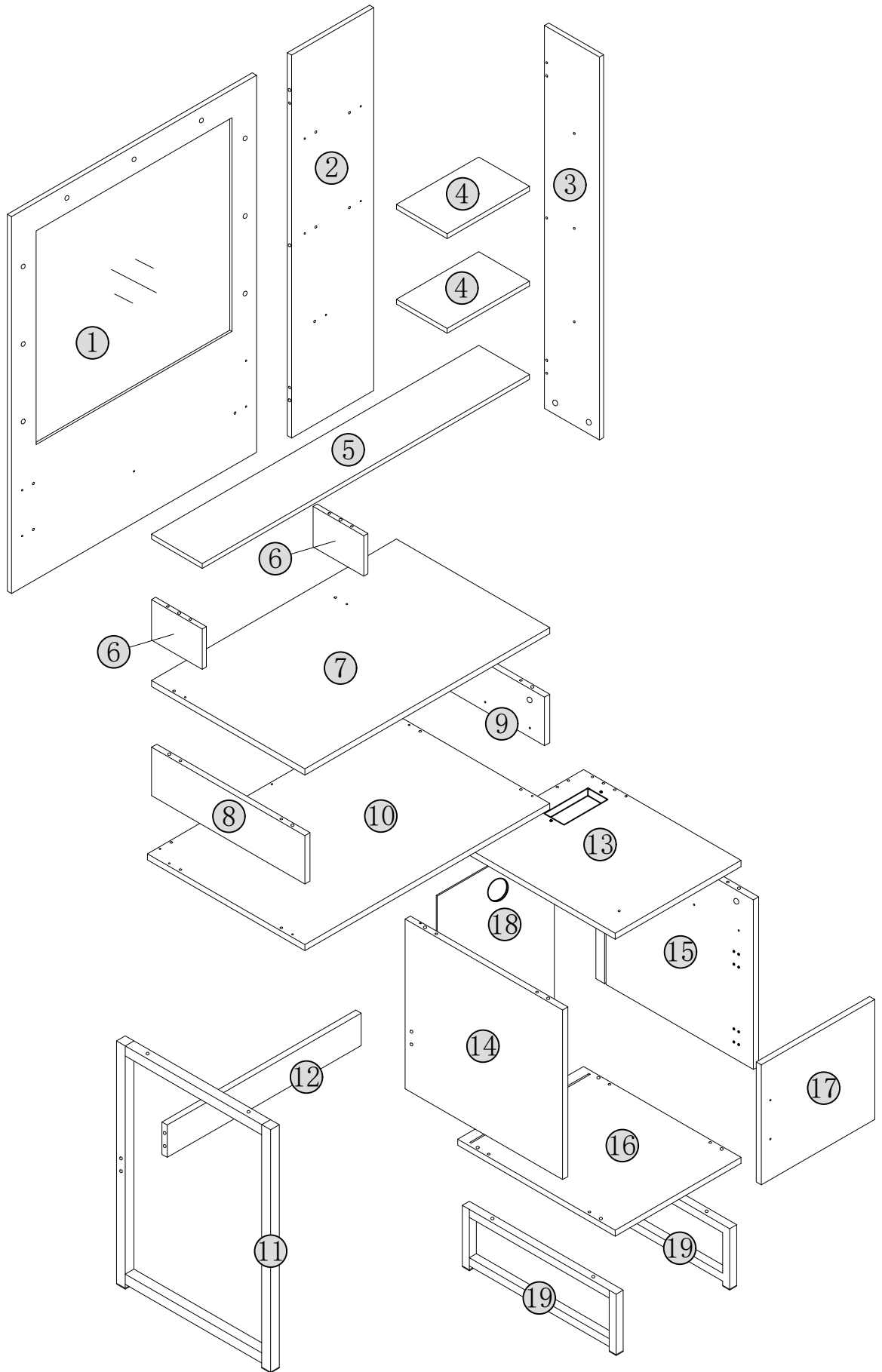

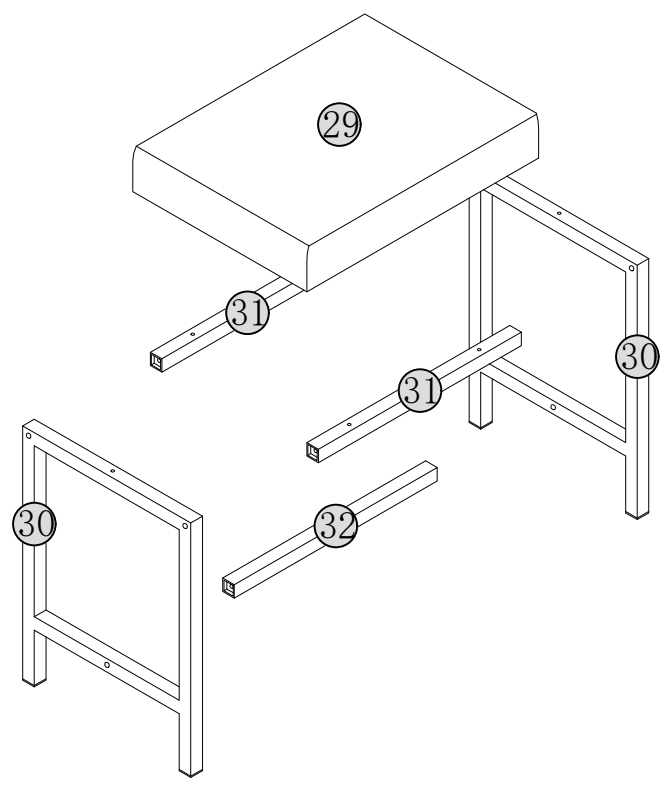
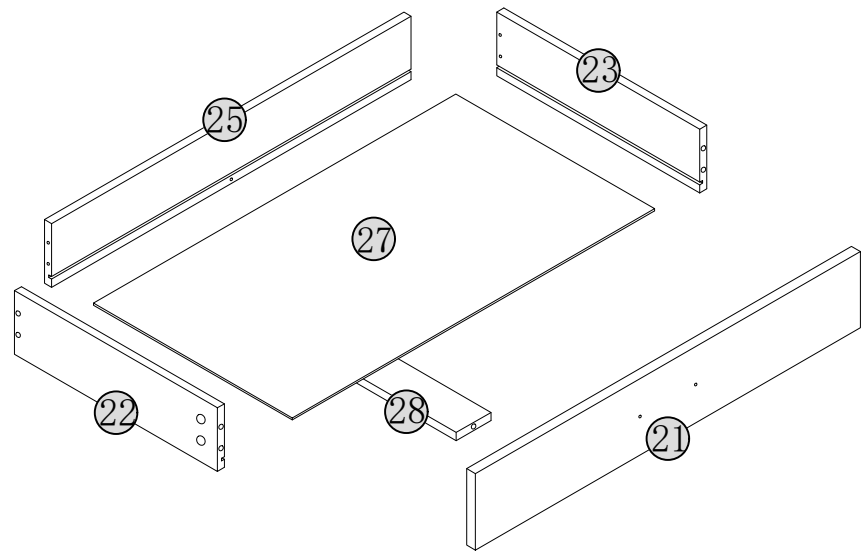
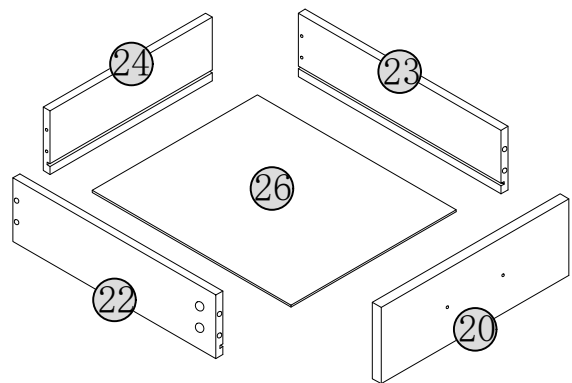

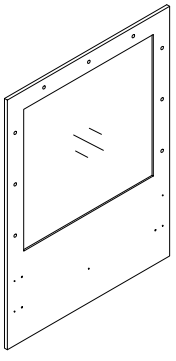
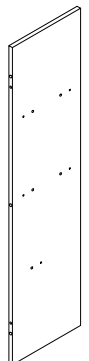

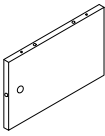
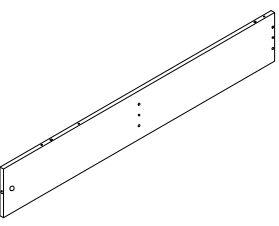
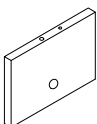
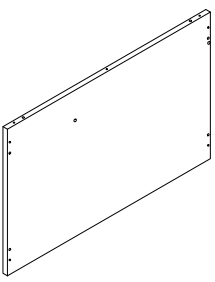
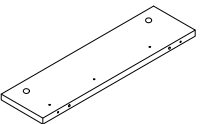
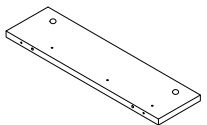
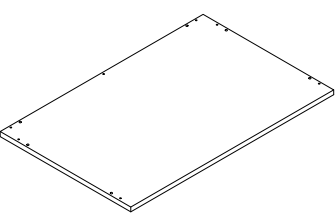
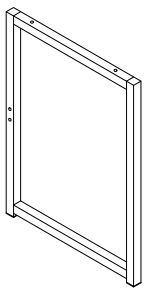
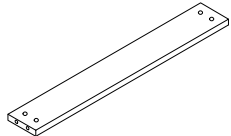
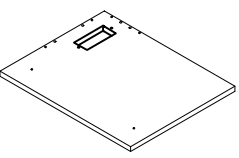
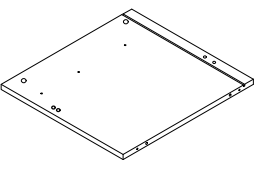
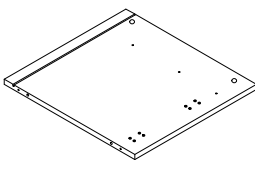
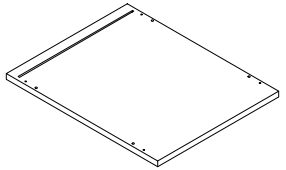
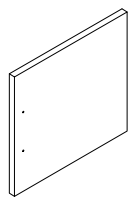
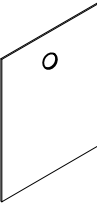
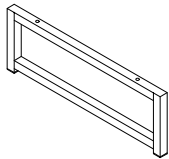
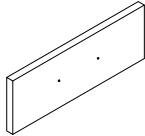
<p>①</p>  <p>1PC</p>	<p>②</p>  <p>1PC</p>	<p>③</p>  <p>1PC</p>	<p>④</p>  <p>2PCS</p>
<p>⑤</p>  <p>1PC</p>	<p>⑥</p>  <p>2PCS</p>	<p>⑦</p>  <p>1PC</p>	<p>⑧</p>  <p>1PC</p>
<p>⑨</p>  <p>1PC</p>	<p>⑩</p>  <p>1PC</p>	<p>⑪</p>  <p>1PC</p>	<p>⑫</p>  <p>1PC</p>
<p>⑬</p>  <p>1PC</p>	<p>⑭</p>  <p>1PC</p>	<p>⑮</p>  <p>1PC</p>	<p>⑯</p>  <p>1PC</p>
<p>⑰</p>  <p>1PC</p>	<p>⑱</p>  <p>1PC</p>	<p>⑲</p>  <p>2PCS</p>	<p>⑳</p>  <p>1PC</p>

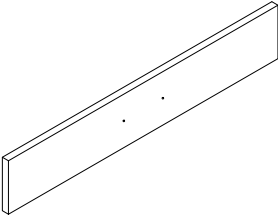
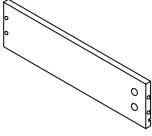
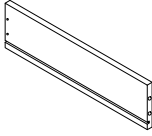
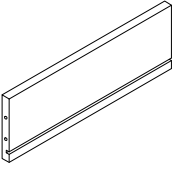
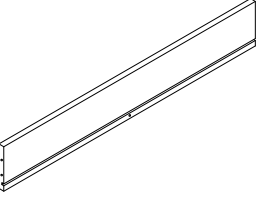
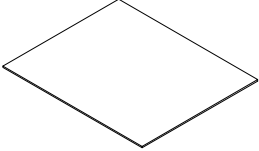
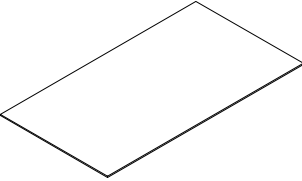
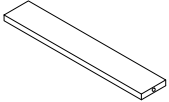
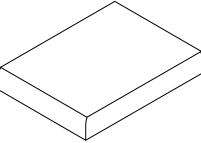
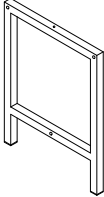
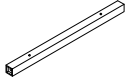
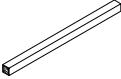
<p>②1</p>  <p>1PC</p>	<p>②2</p>  <p>2PCS</p>	<p>②3</p>  <p>2PCS</p>	<p>②4</p>  <p>1PC</p>
<p>②5</p>  <p>1PC</p>	<p>②6</p>  <p>1PC</p>	<p>②7</p>  <p>1PC</p>	<p>②8</p>  <p>1PC</p>
<p>②9</p>  <p>1PC</p>	<p>③0</p>  <p>2PCS</p>	<p>③1</p>  <p>2PCS</p>	<p>③2</p>  <p>1PC</p>

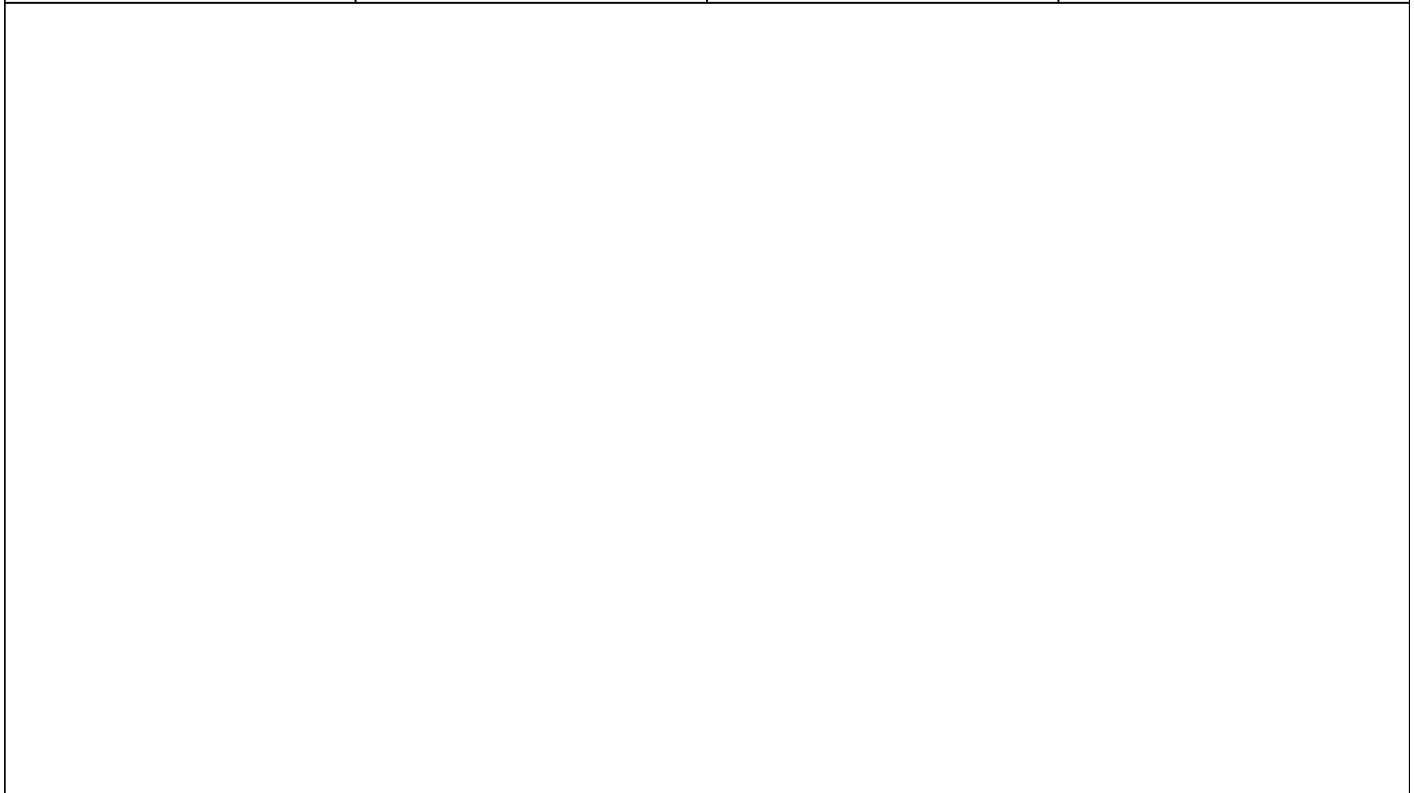

A×32 +1



B×9

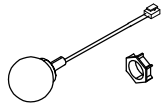

C×26 +1

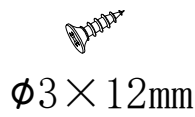

D×38 +1



E×32 +1

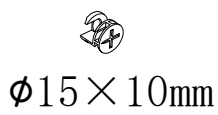

F×23 +1

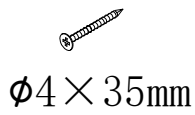

G×2

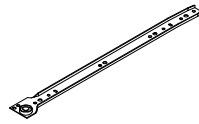

H×2

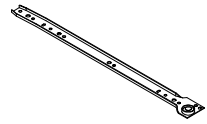

I×2



J×1



K×4



L×4

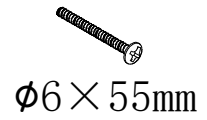

M×6

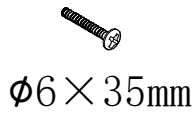

N×6



O×2



P×12+1



Q×3



R×6



S×15 +1

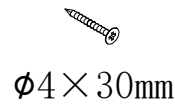

T×2

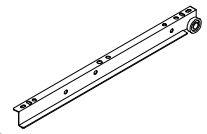

U×2

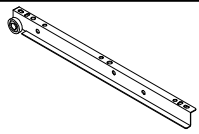

V×1

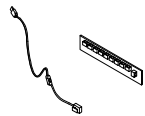

W×1

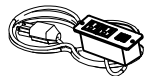

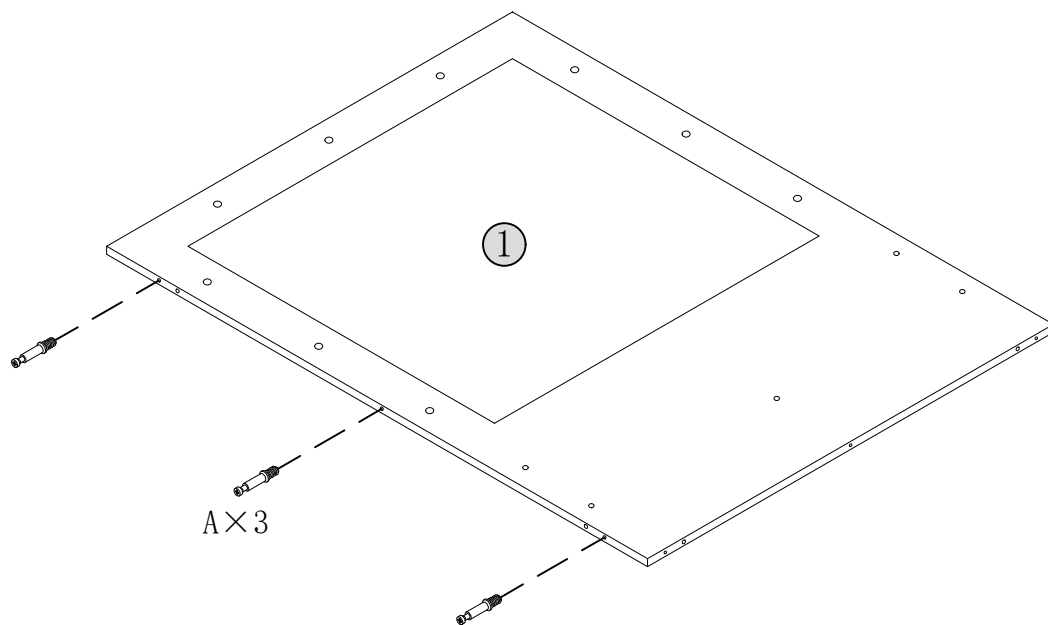

1

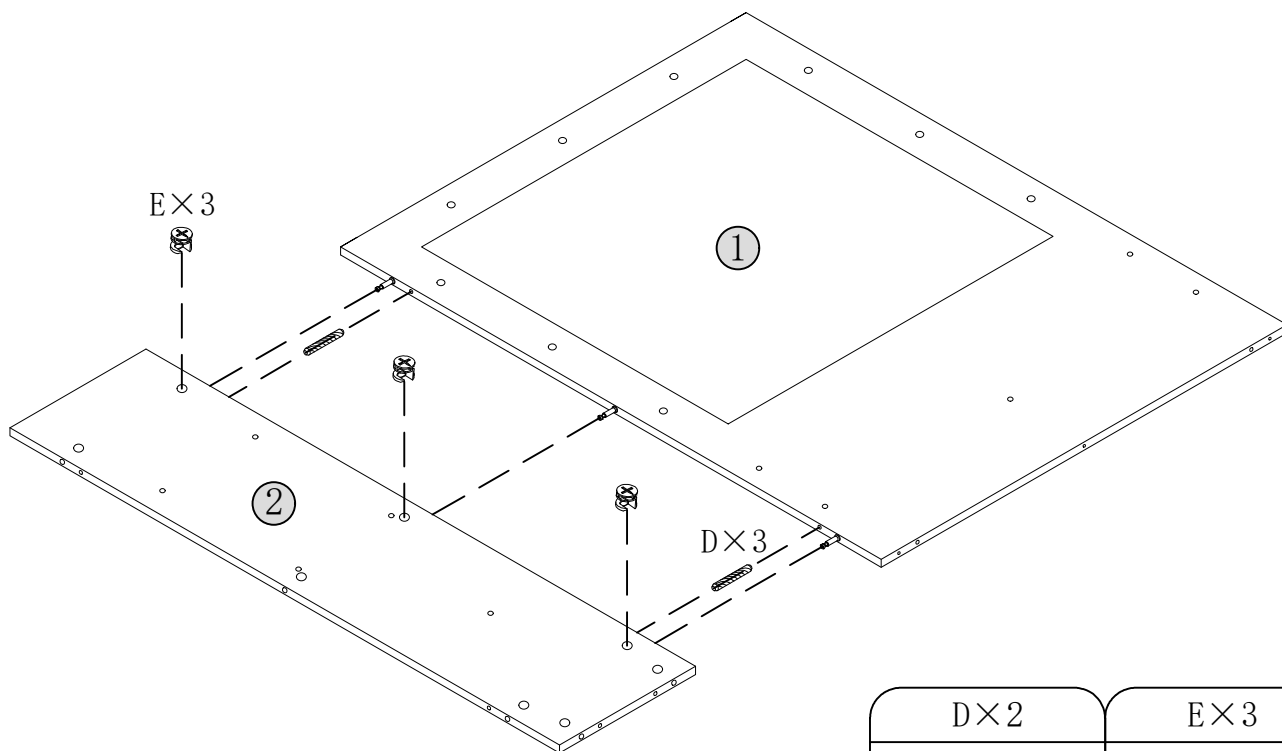

A x 3

φ6 x 35mm

2



D x 2

φ6 x 30mm

E x 3

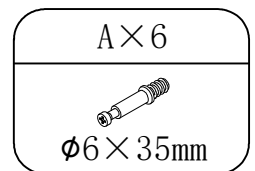
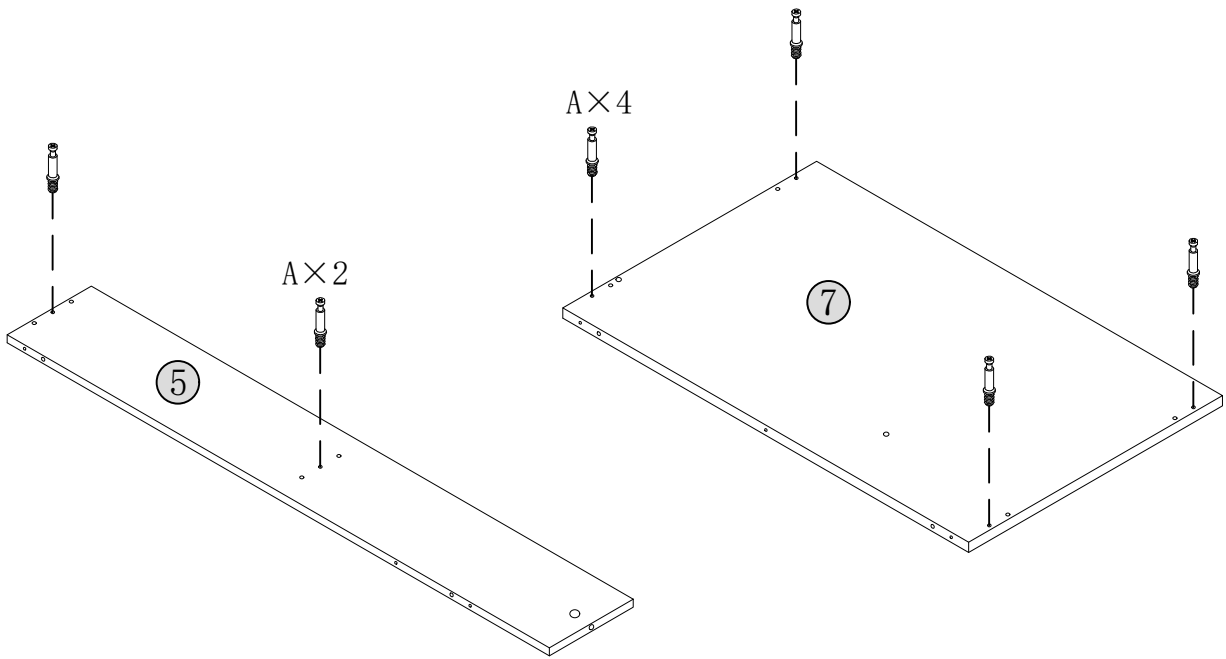
φ15 x 10mm

3

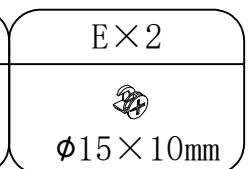
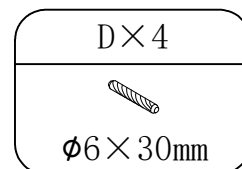
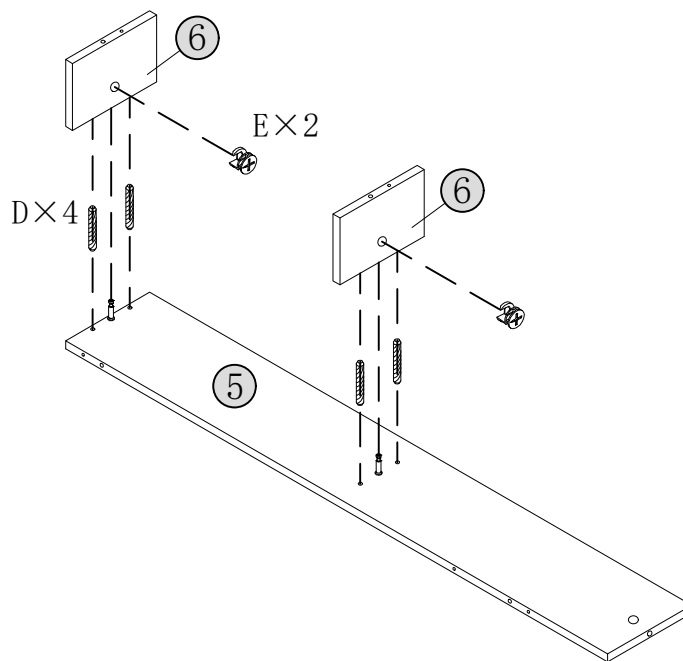



4



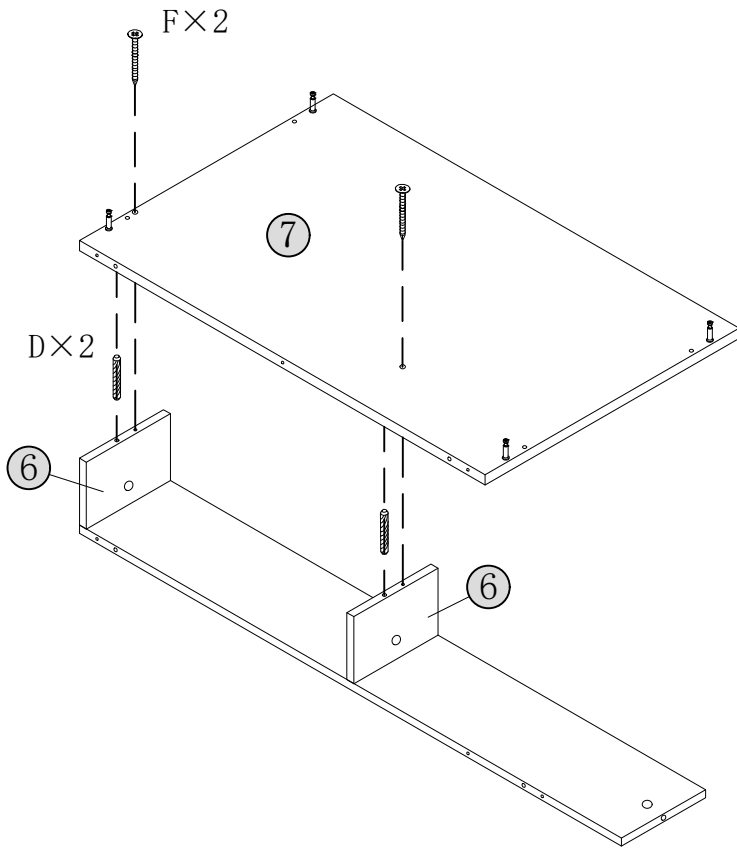

5



D x 2	F x 2
	
φ6 x 30mm	φ4 x 35mm

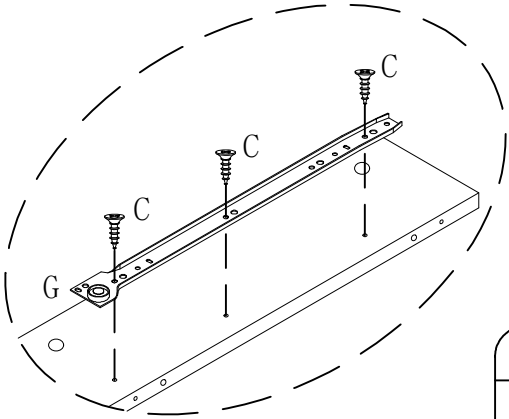
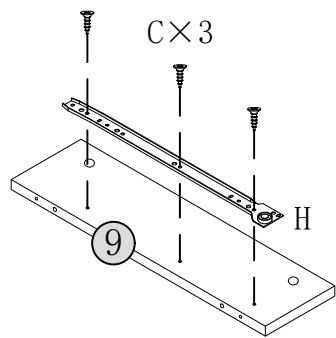
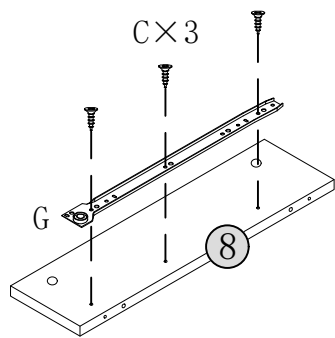

6

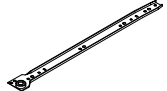
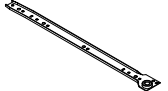

C x 6	G x 1	H x 1
		
φ3 x 12mm		

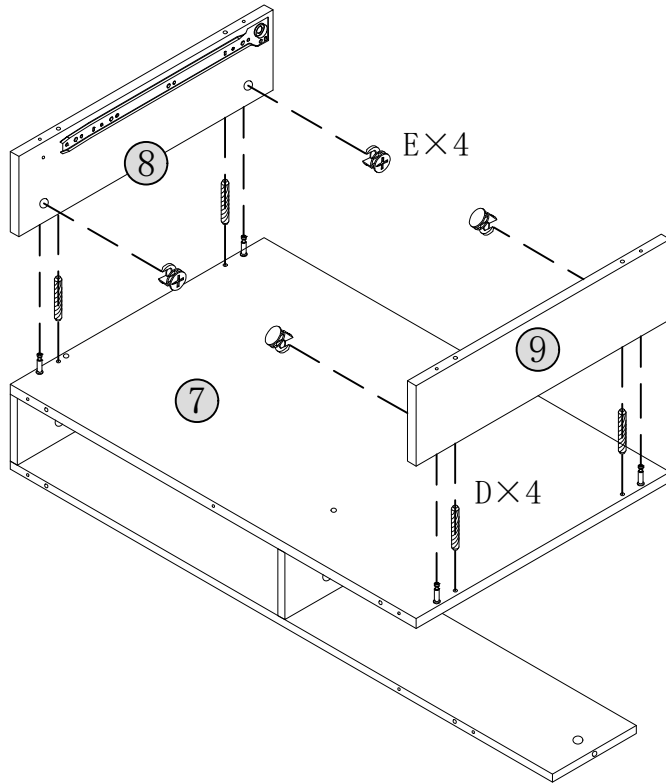

7

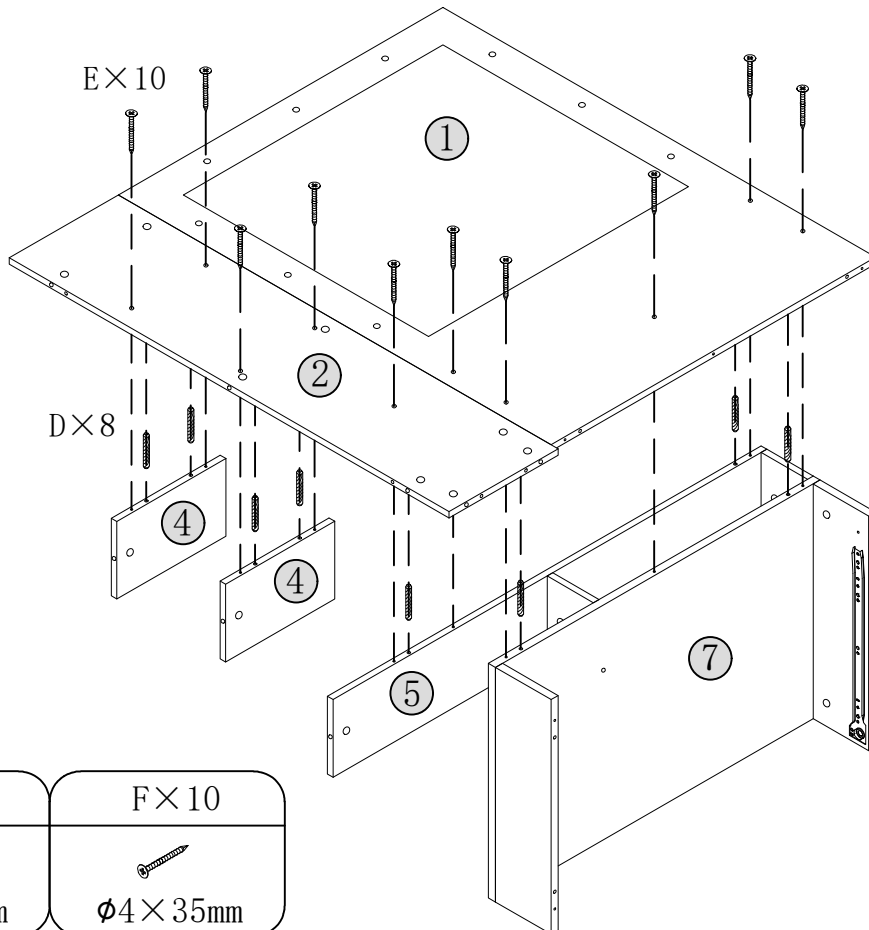

D x 4	E x 4
	
$\phi 6 \times 30\text{mm}$	$\phi 15 \times 10\text{mm}$

8



D x 8	F x 10
	
$\phi 6 \times 30\text{mm}$	$\phi 4 \times 35\text{mm}$

9

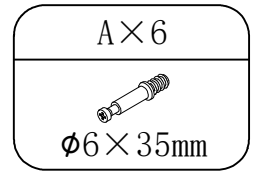
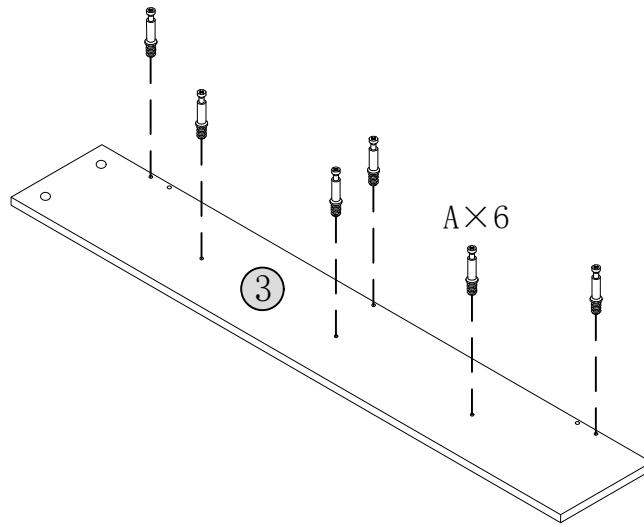

10

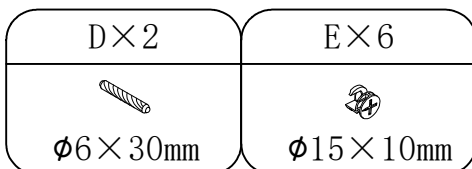
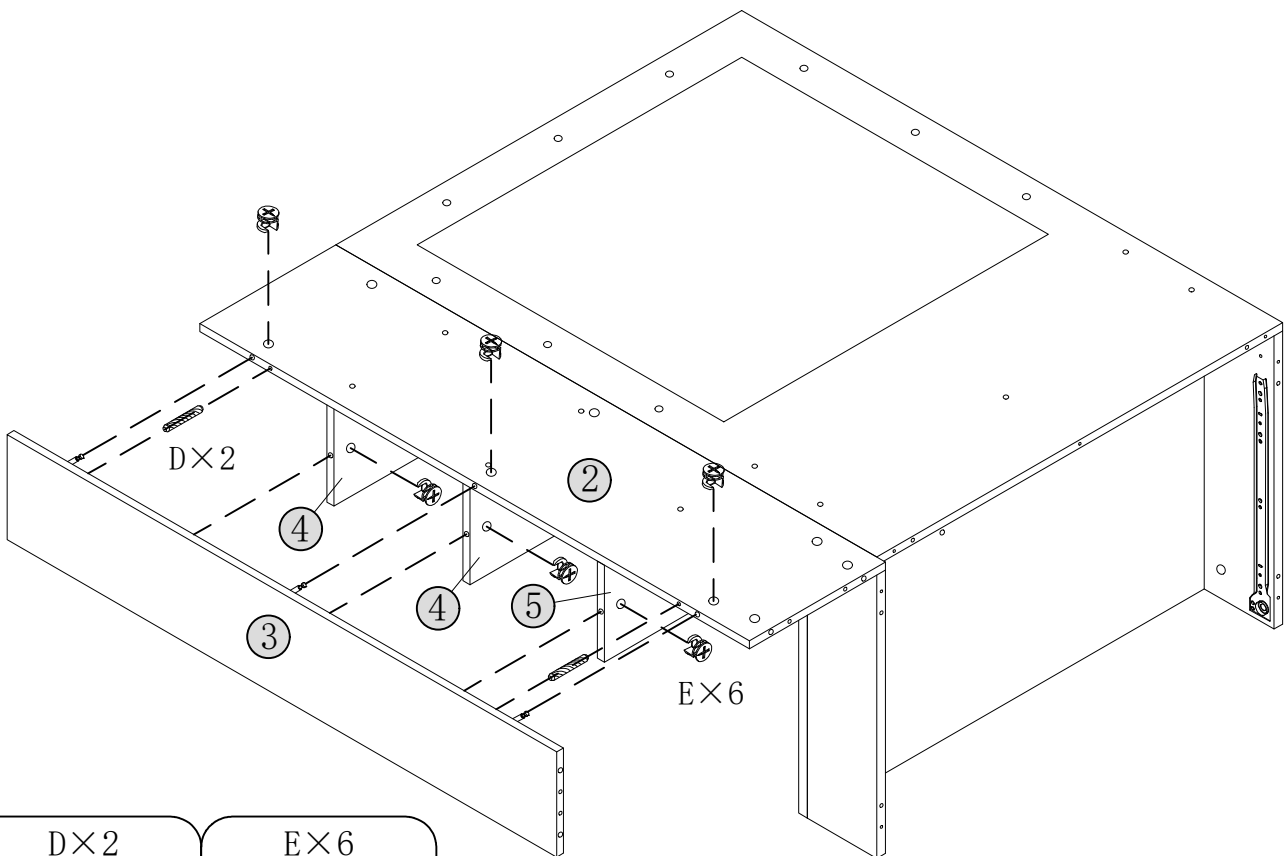

11

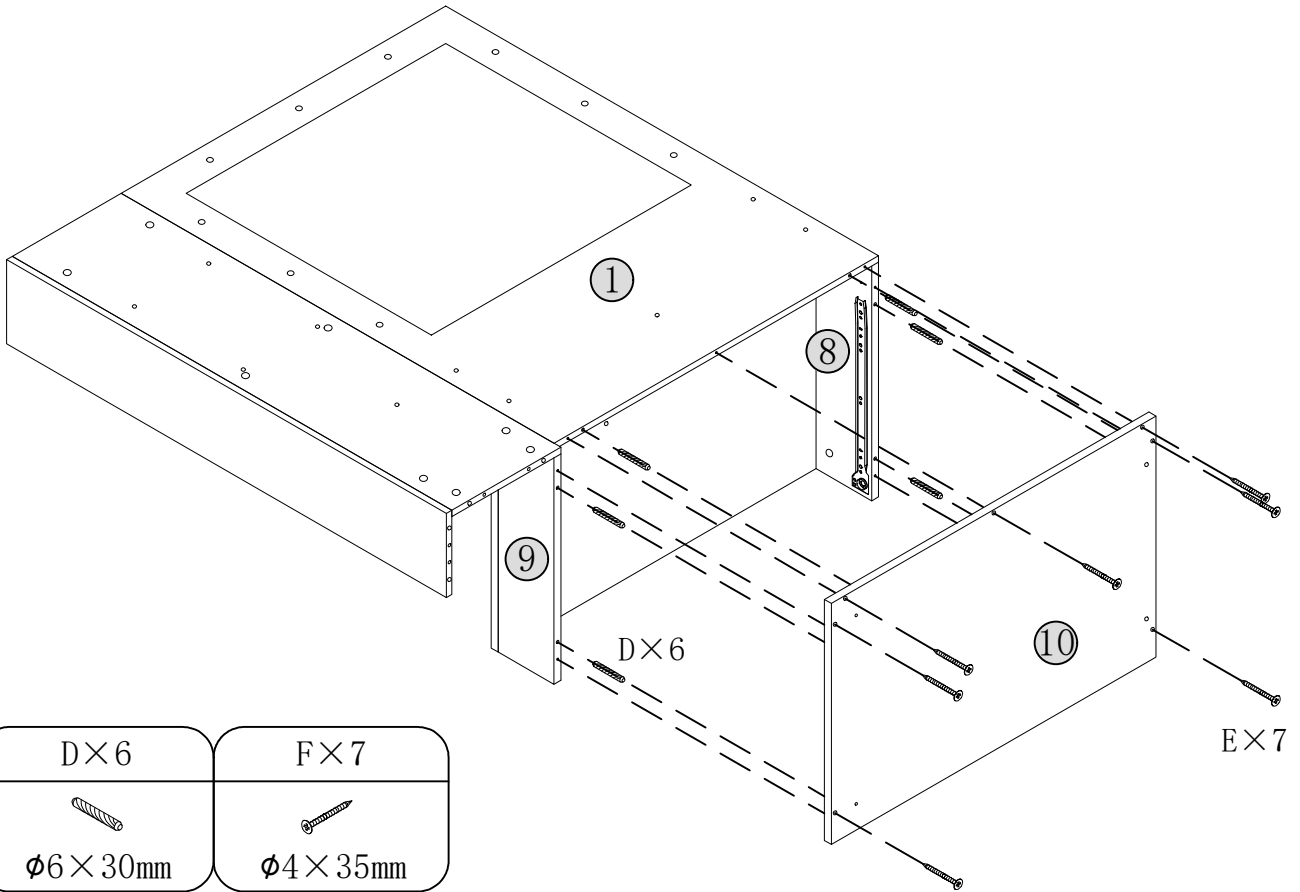

12

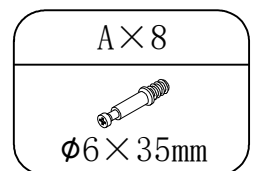
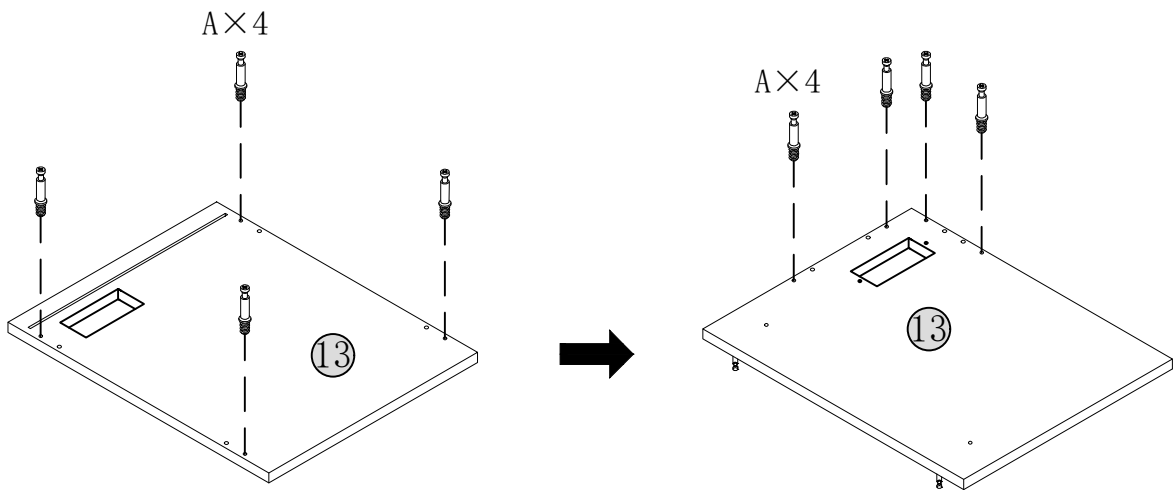

13

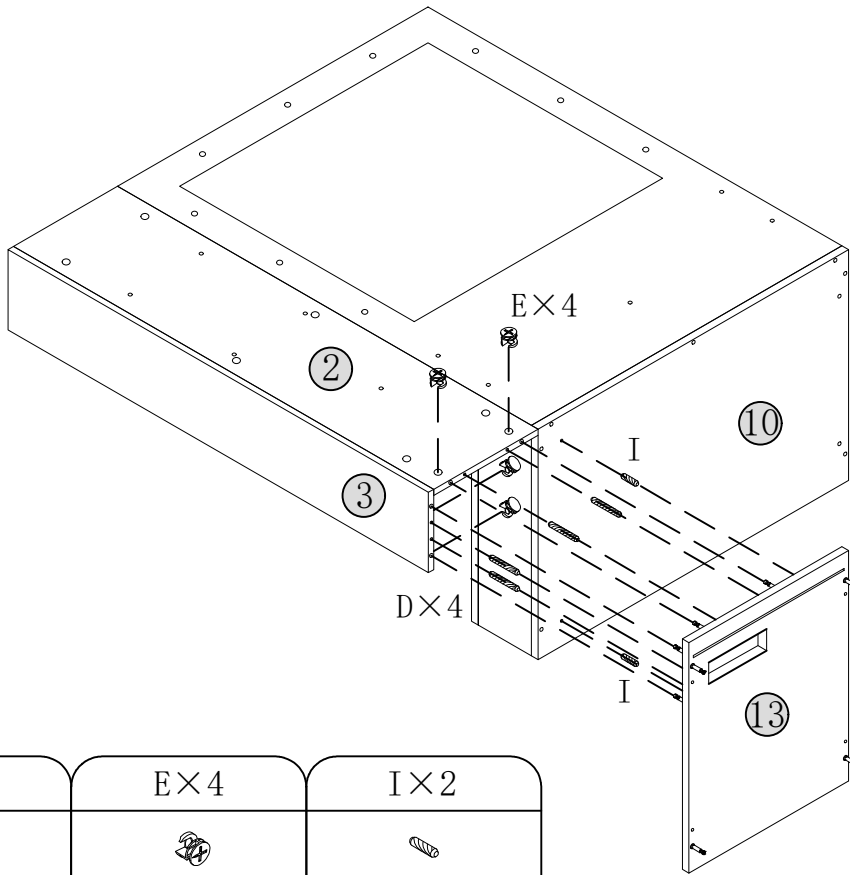

D×4	E×4	I×2
∅6×30mm	∅15×10mm	∅6×20mm

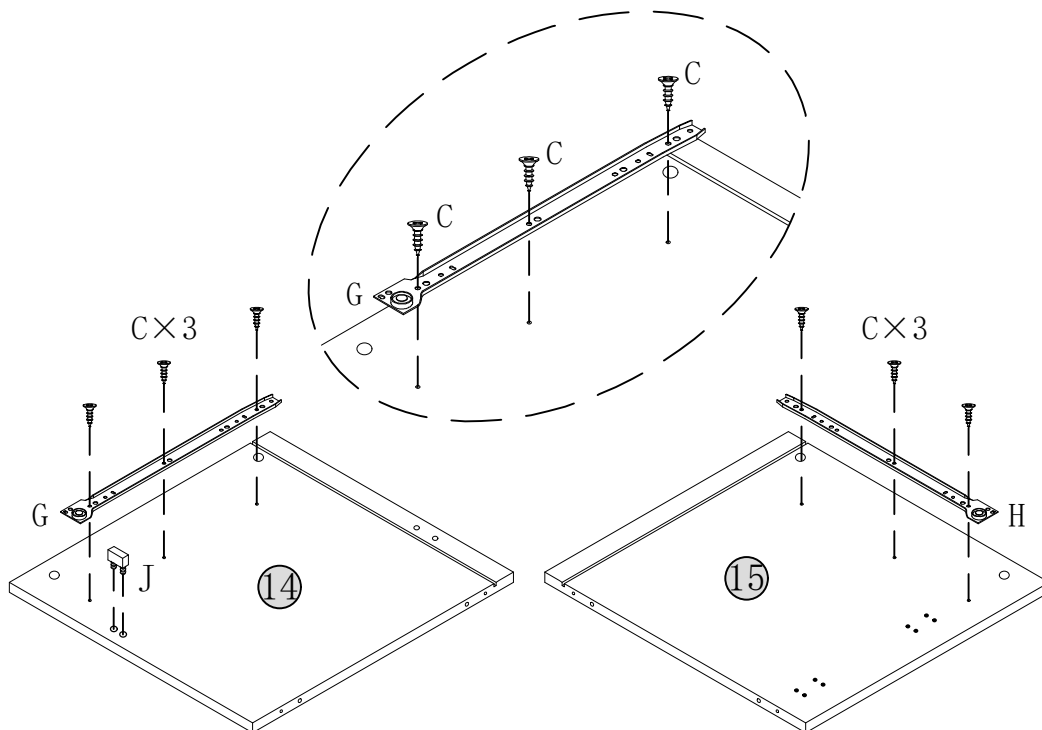

14



C×6	G×1	H×1	J×1
∅3×12mm			

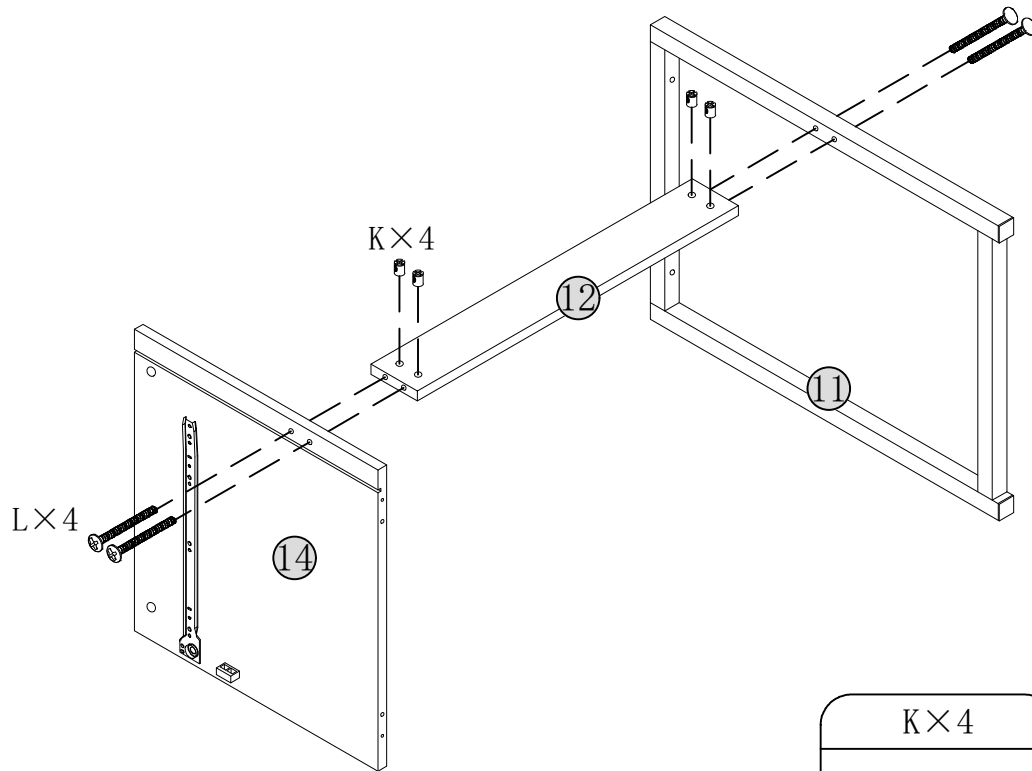

15



K×4	L×4
	
	φ6×55mm

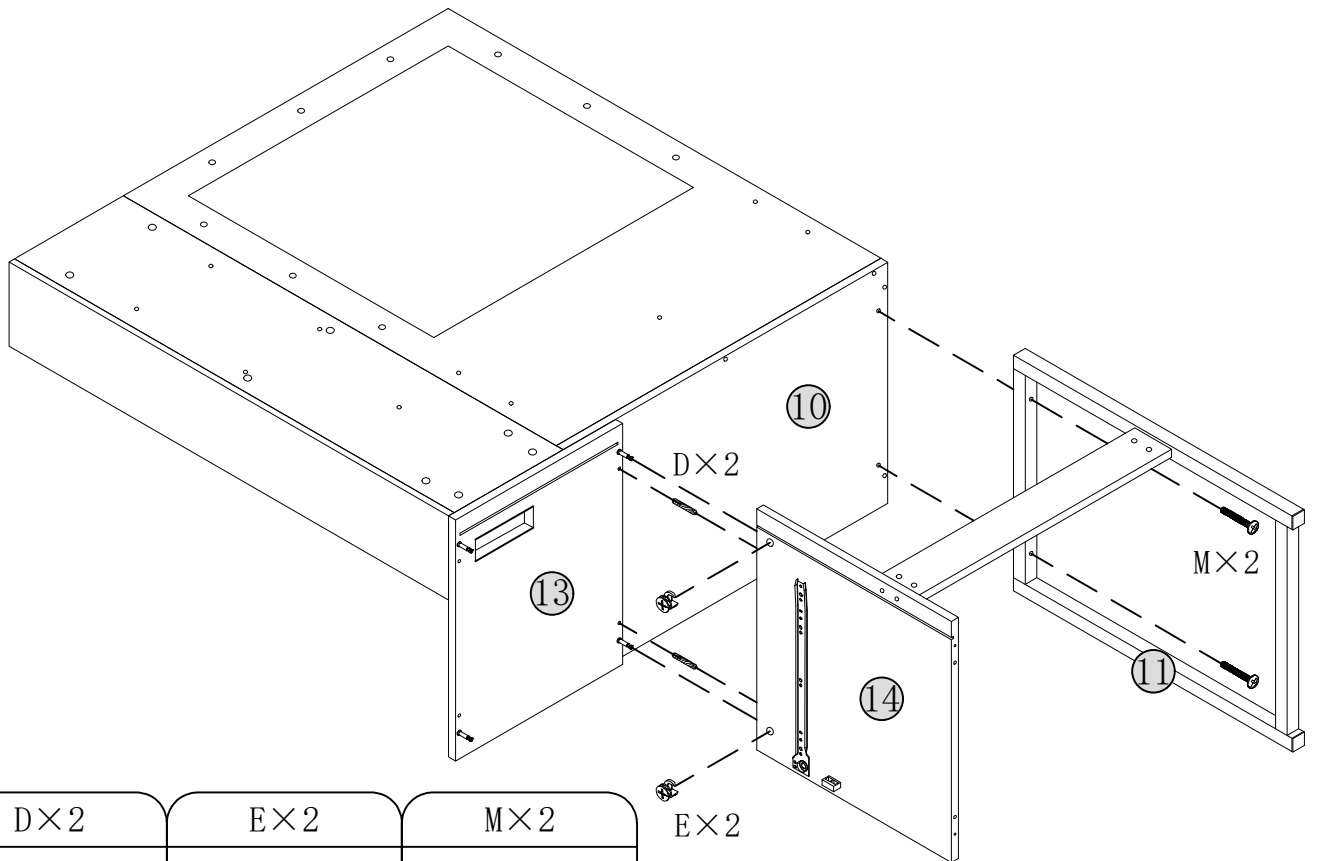

16

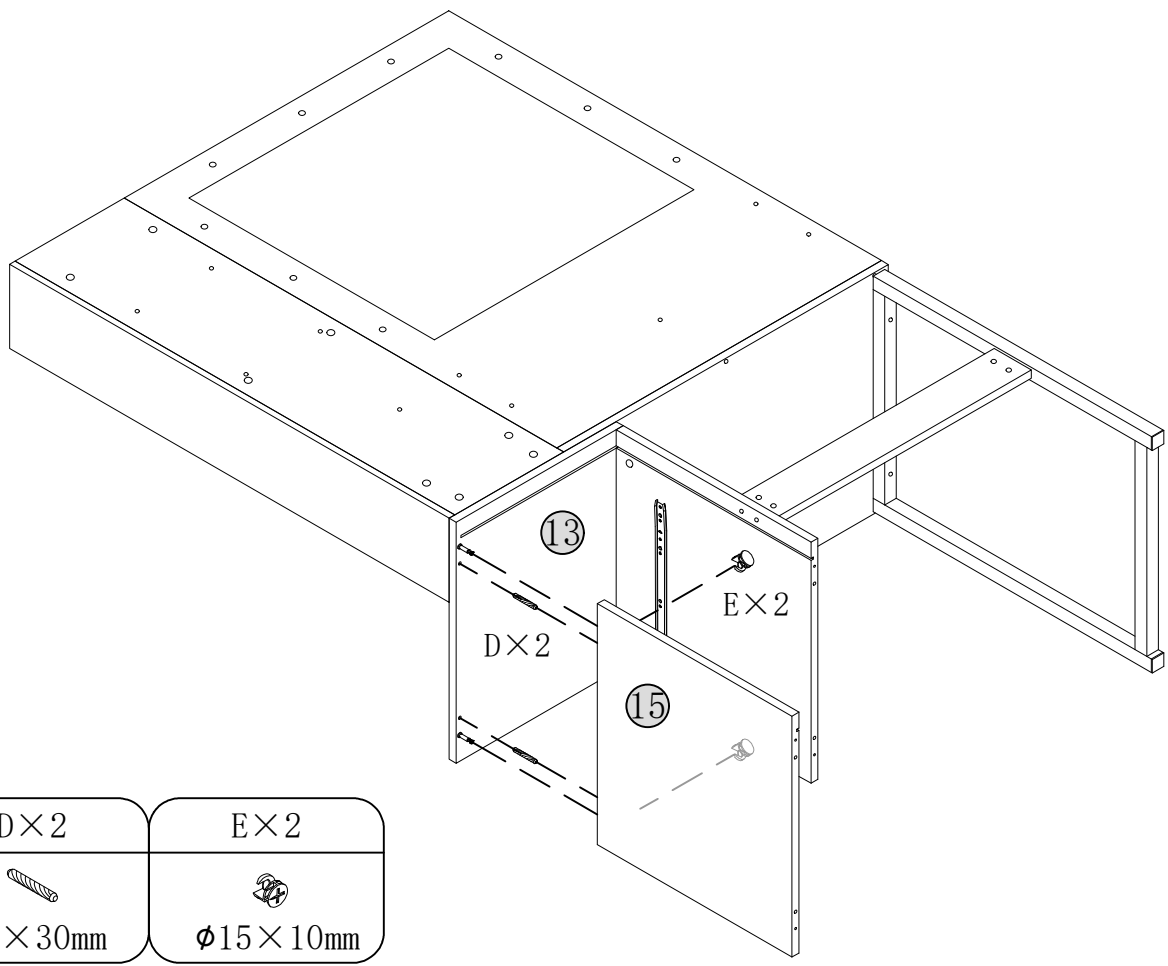

D×2	E×2	M×2
		
φ6×30mm	φ15×10mm	φ6×35mm

17



$D \times 2$	$E \times 2$
	
$\phi 6 \times 30 \text{mm}$	$\phi 15 \times 10 \text{mm}$

18

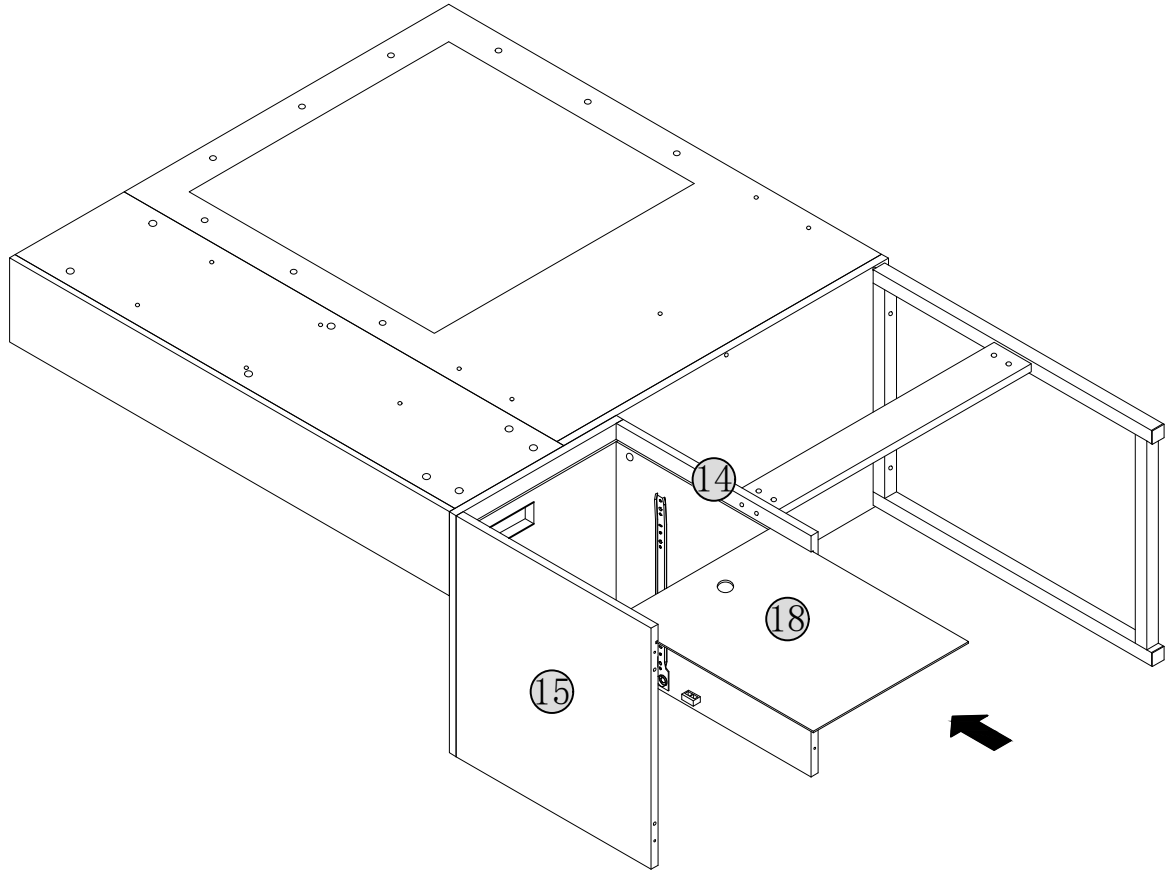

19

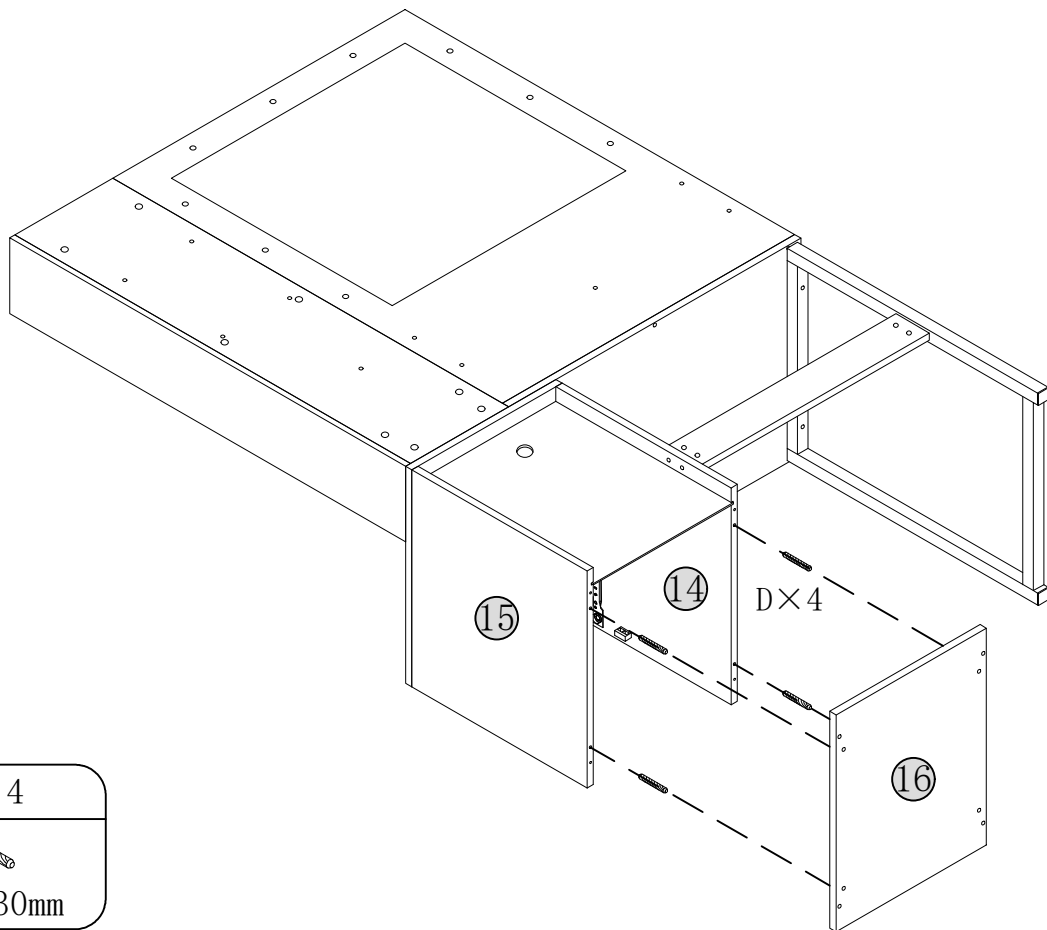

20

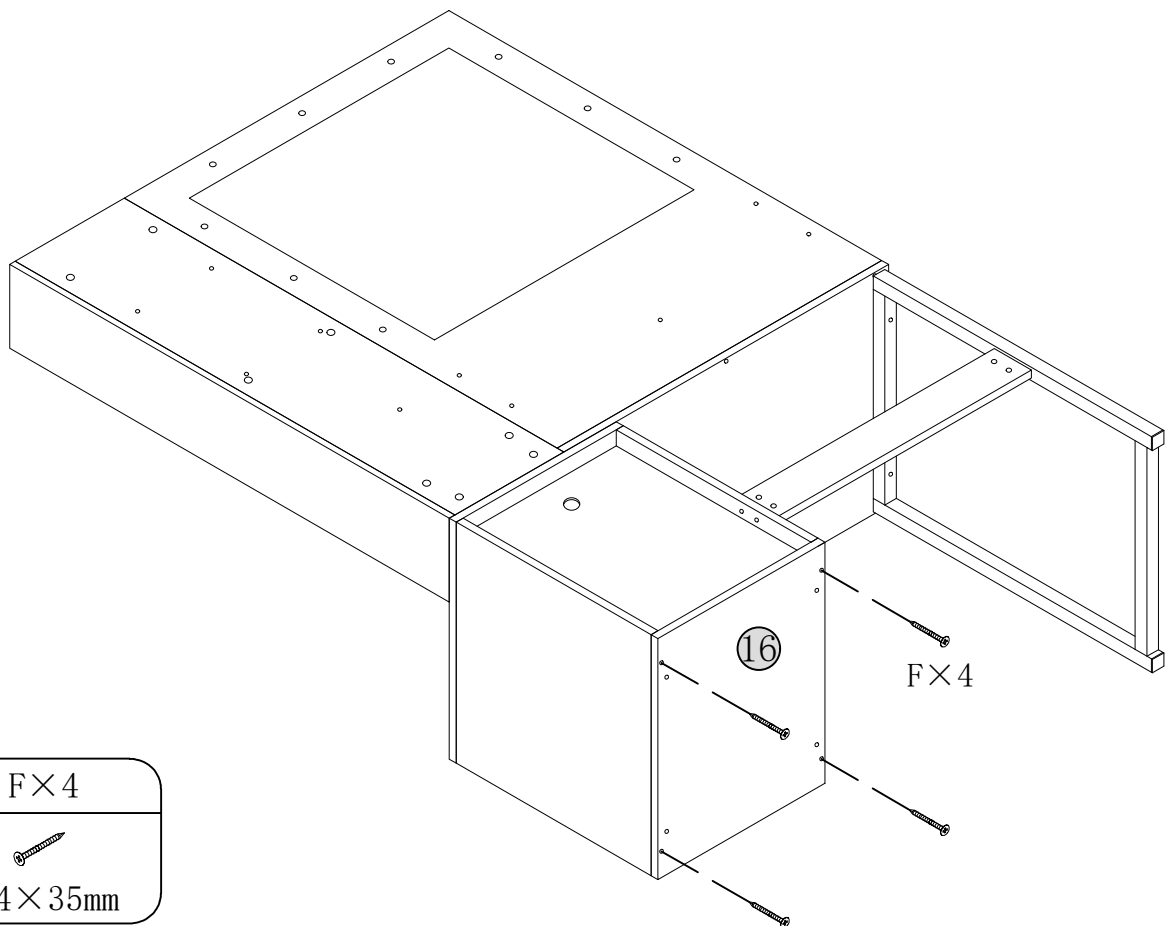



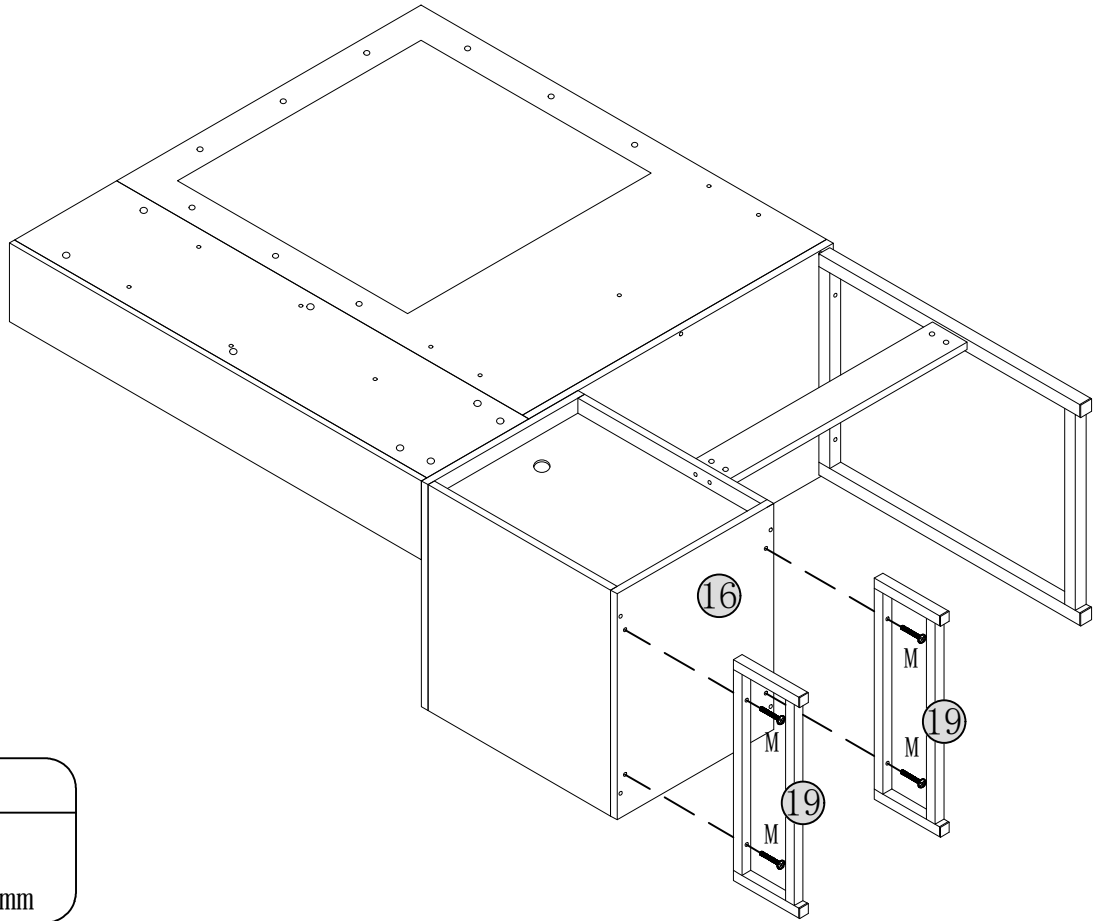

21

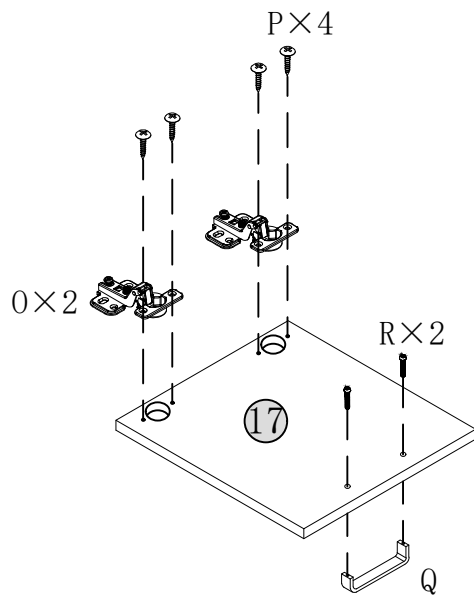

M×4

φ6×35mm

22

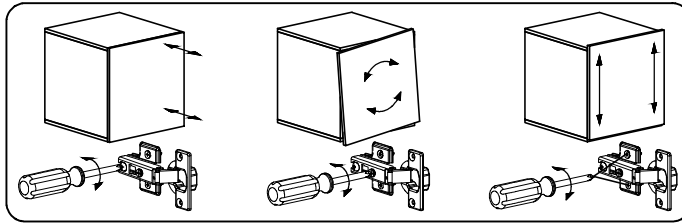

O×2	P×4	Q×1	R×2
	 φ4×14mm		 φ4×18mm



P×8



Ø4×14mm

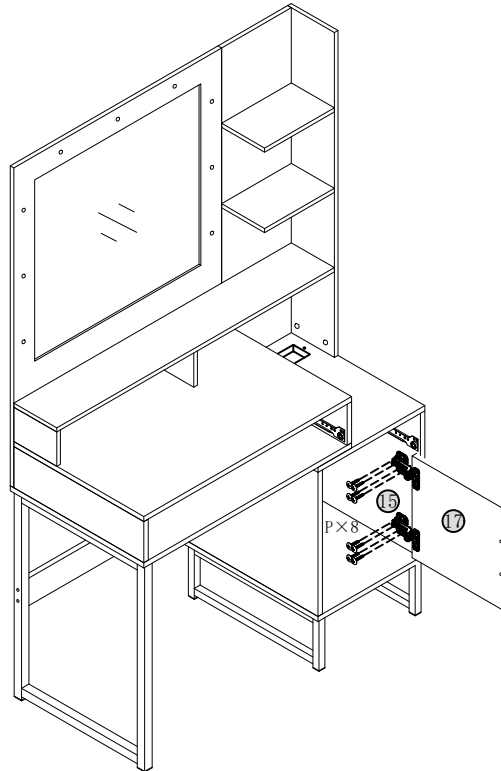

If the door can't close, please adjust the hinges.

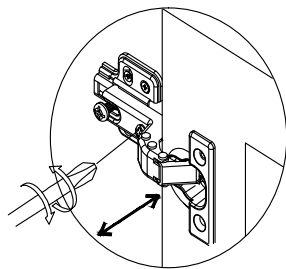

This is used to adjust the door panel in the up and down direction.

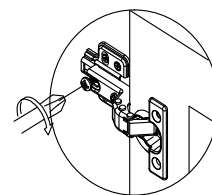
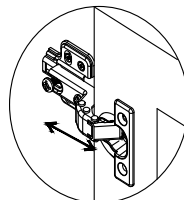
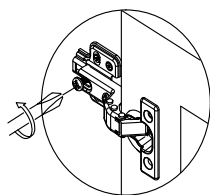

This is used to adjust the door panel in the front and back direction: Loosen the screw first, and then tighten screw after adjusting the door panel to the proper position.

24

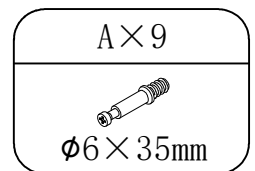
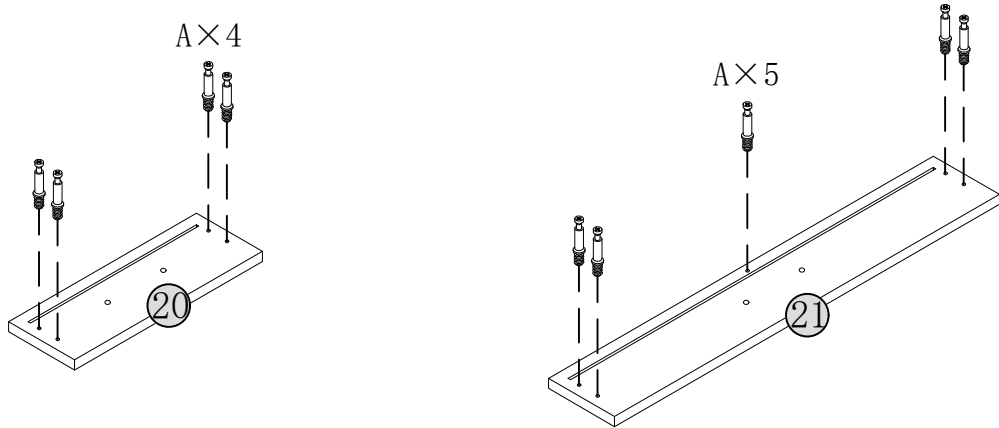

25

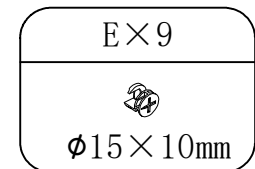
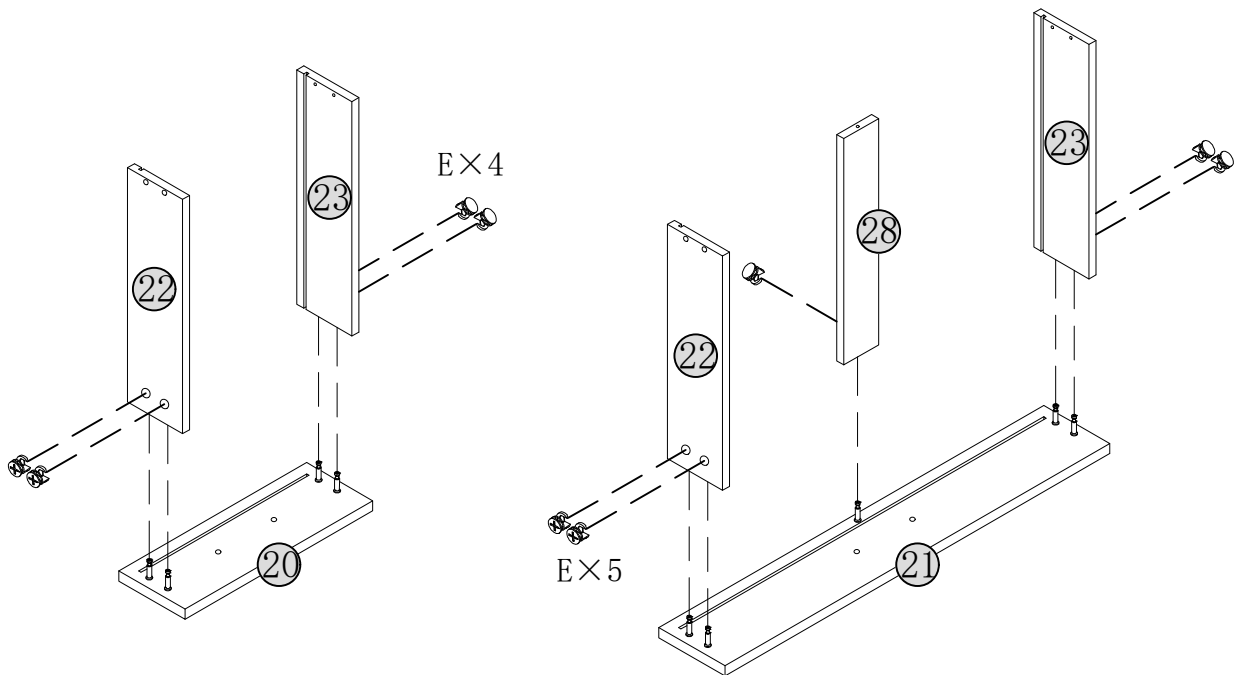

26

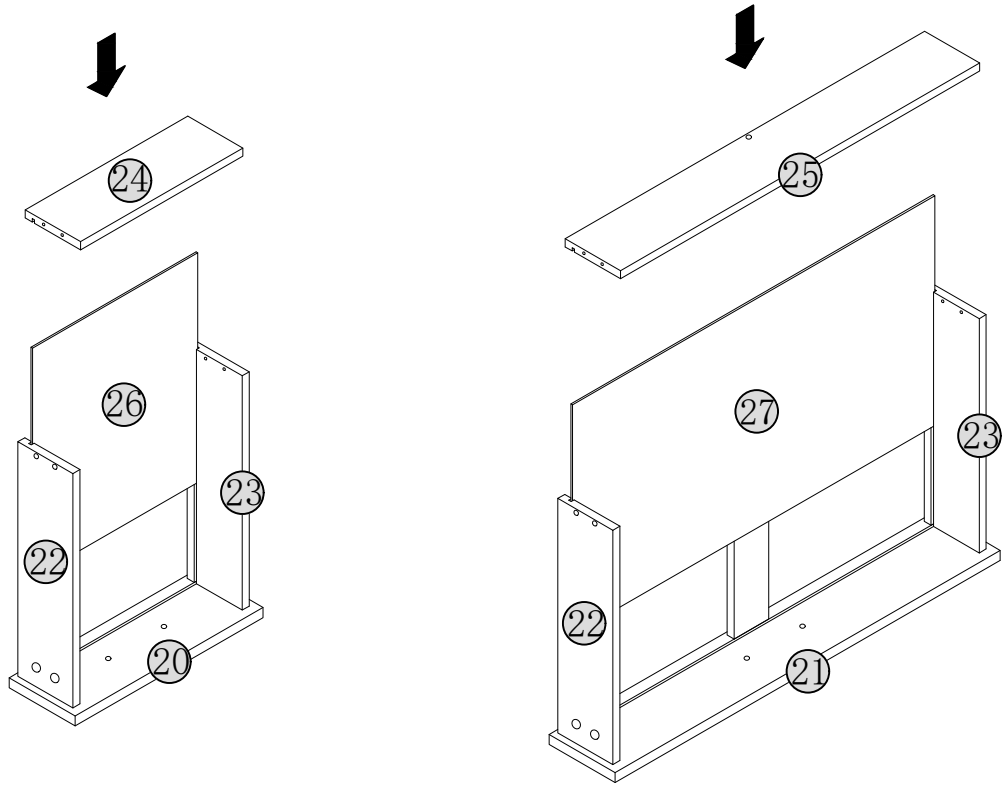

27

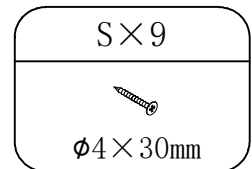
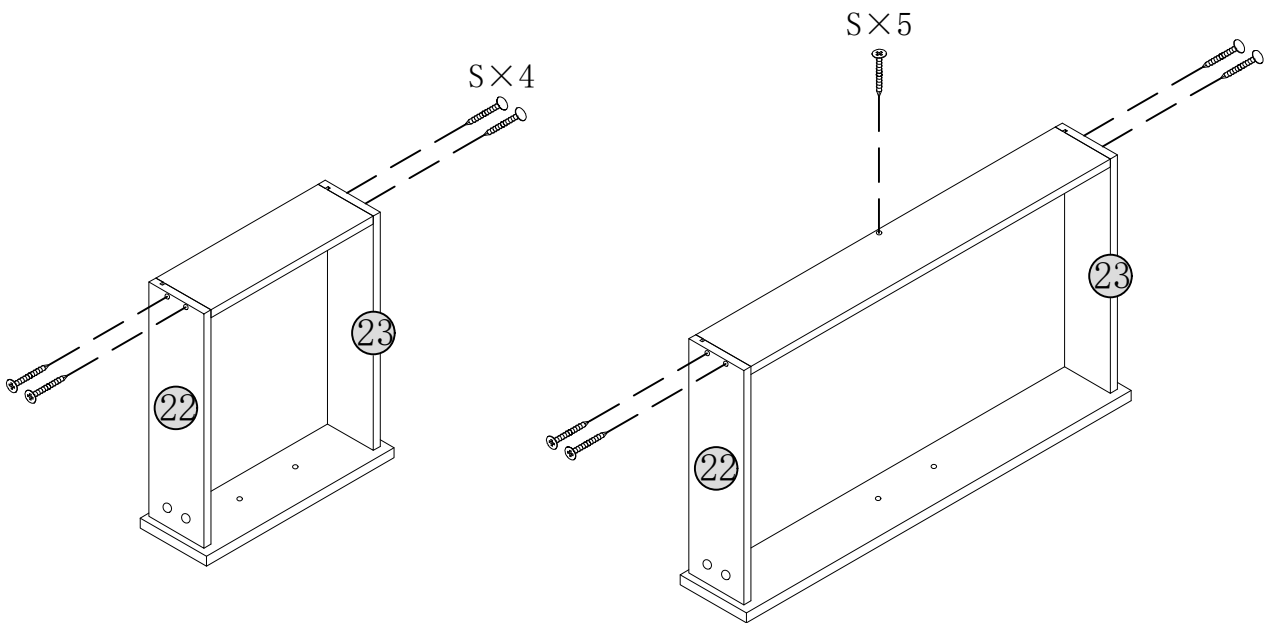

28

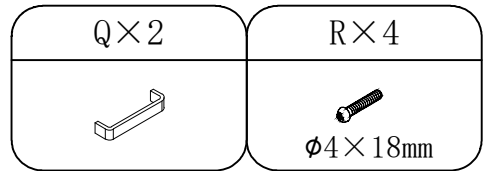
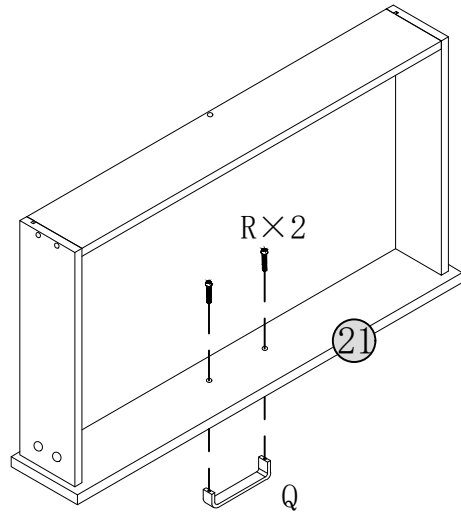
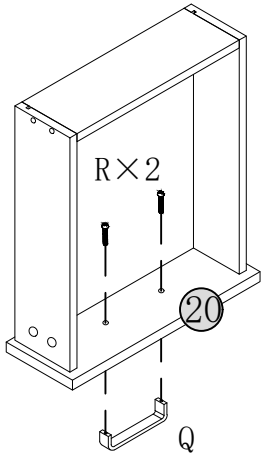

29

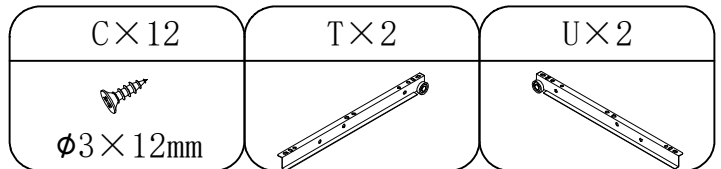
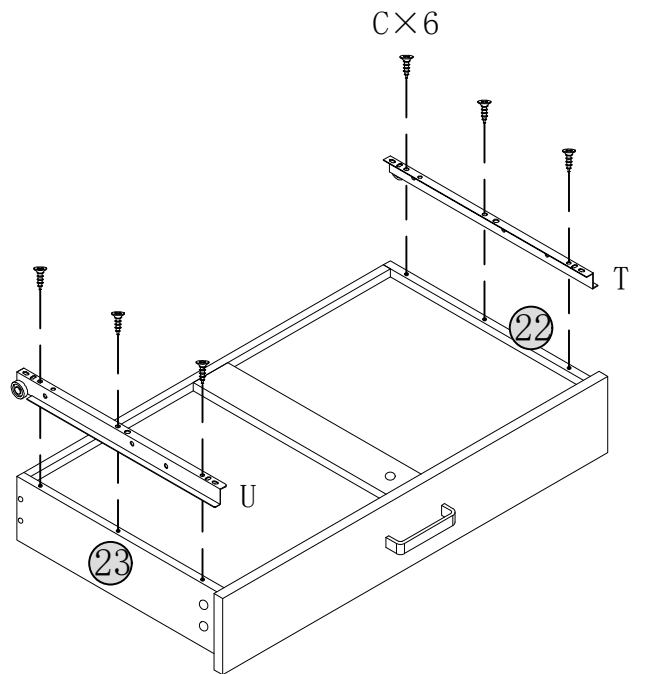
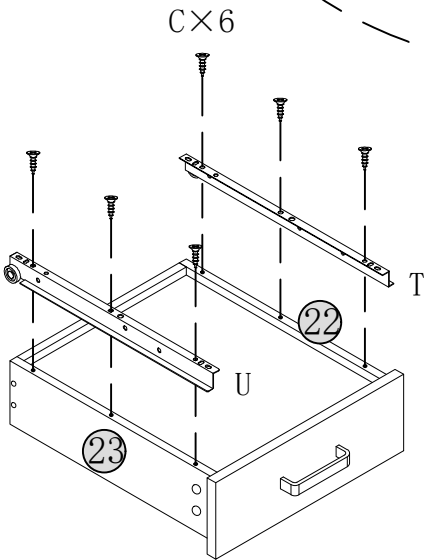
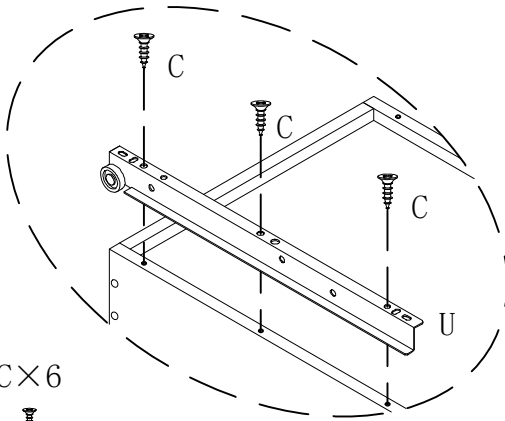

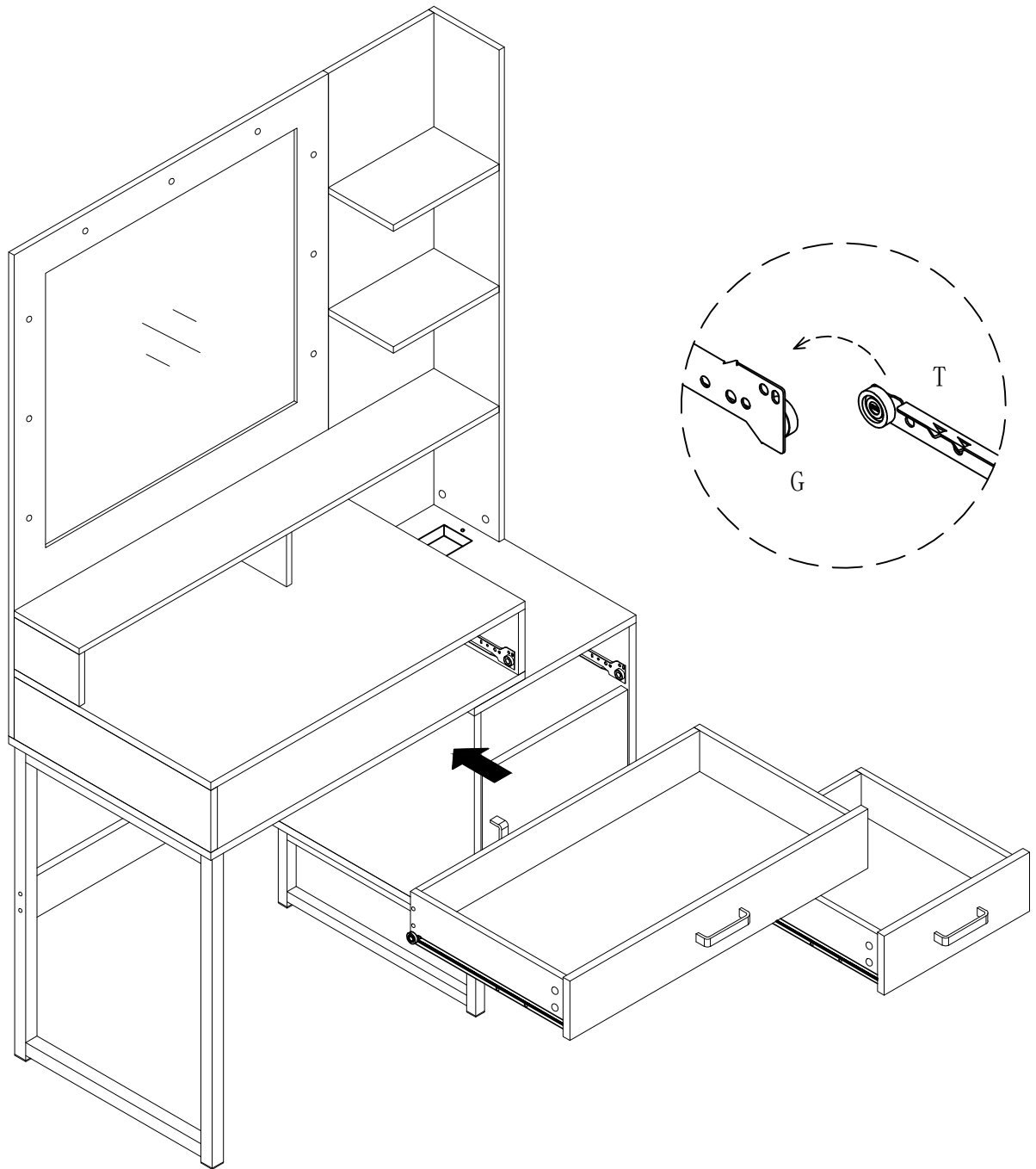

The wheels of the track have to be aligned and pushed along.

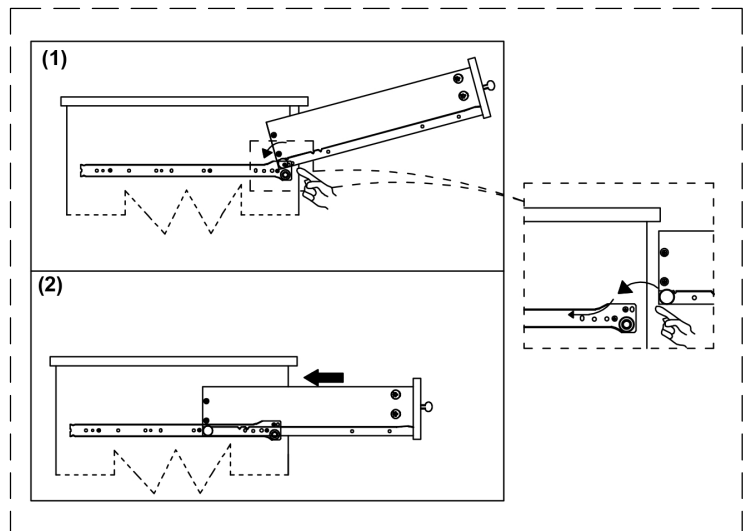

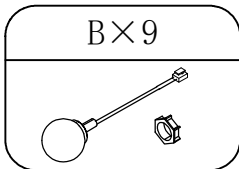
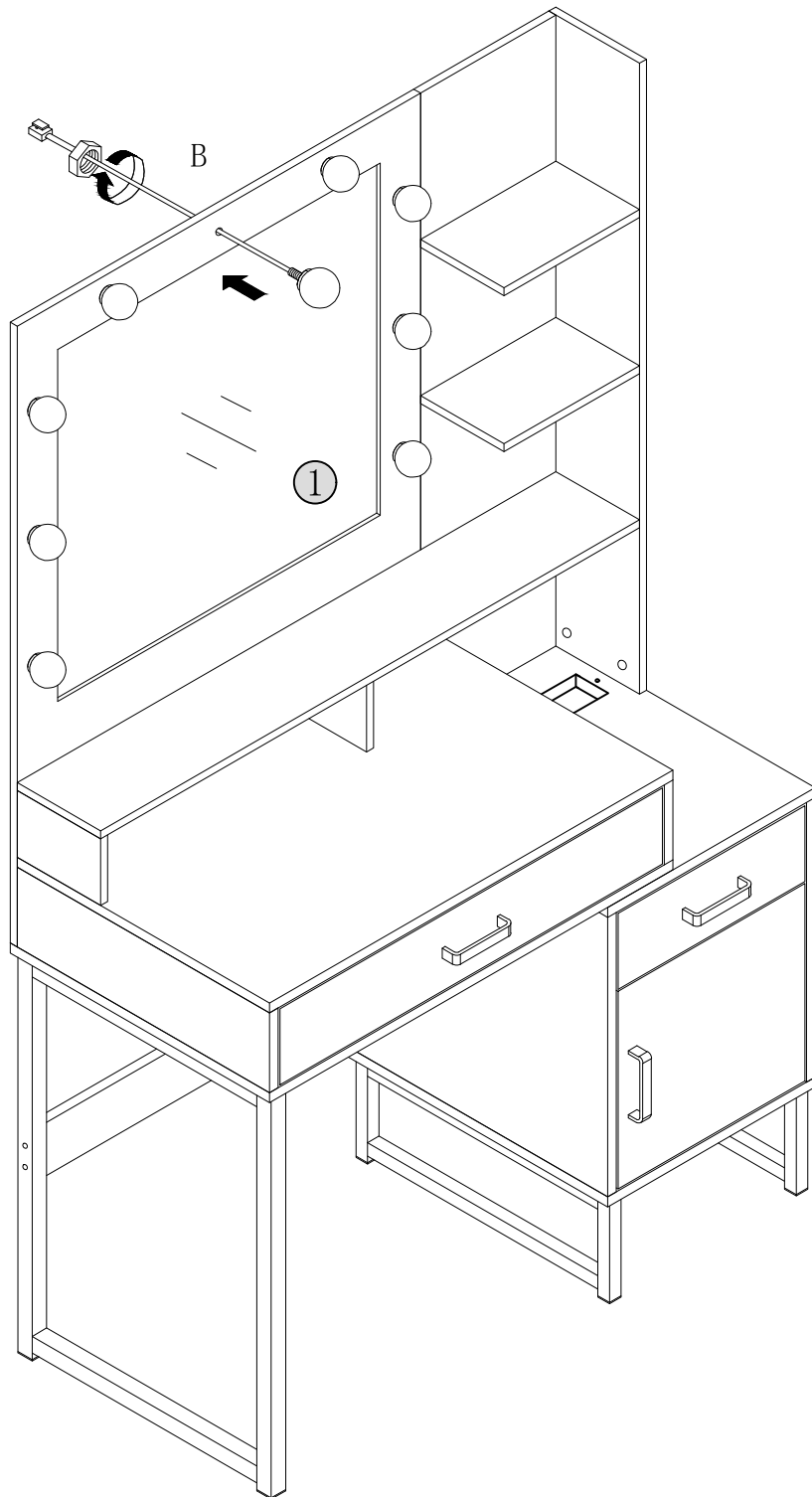

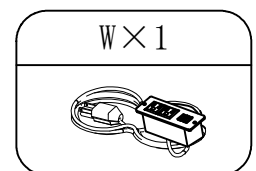
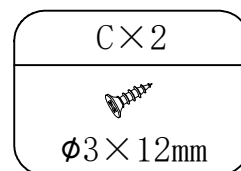
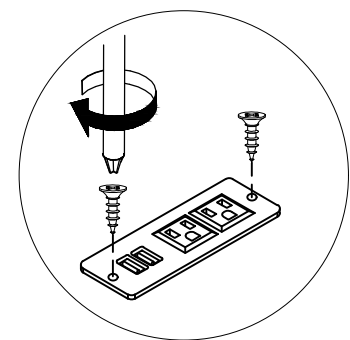
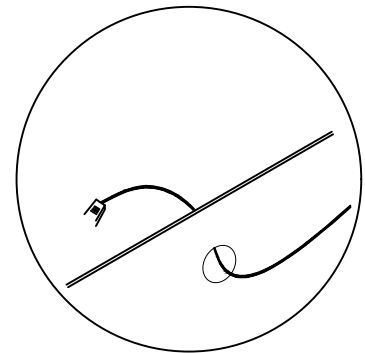
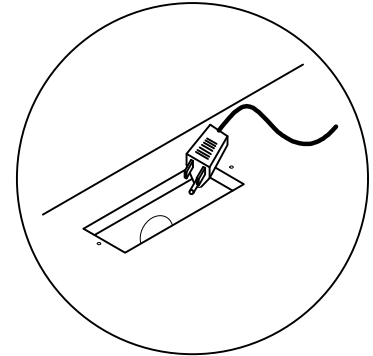
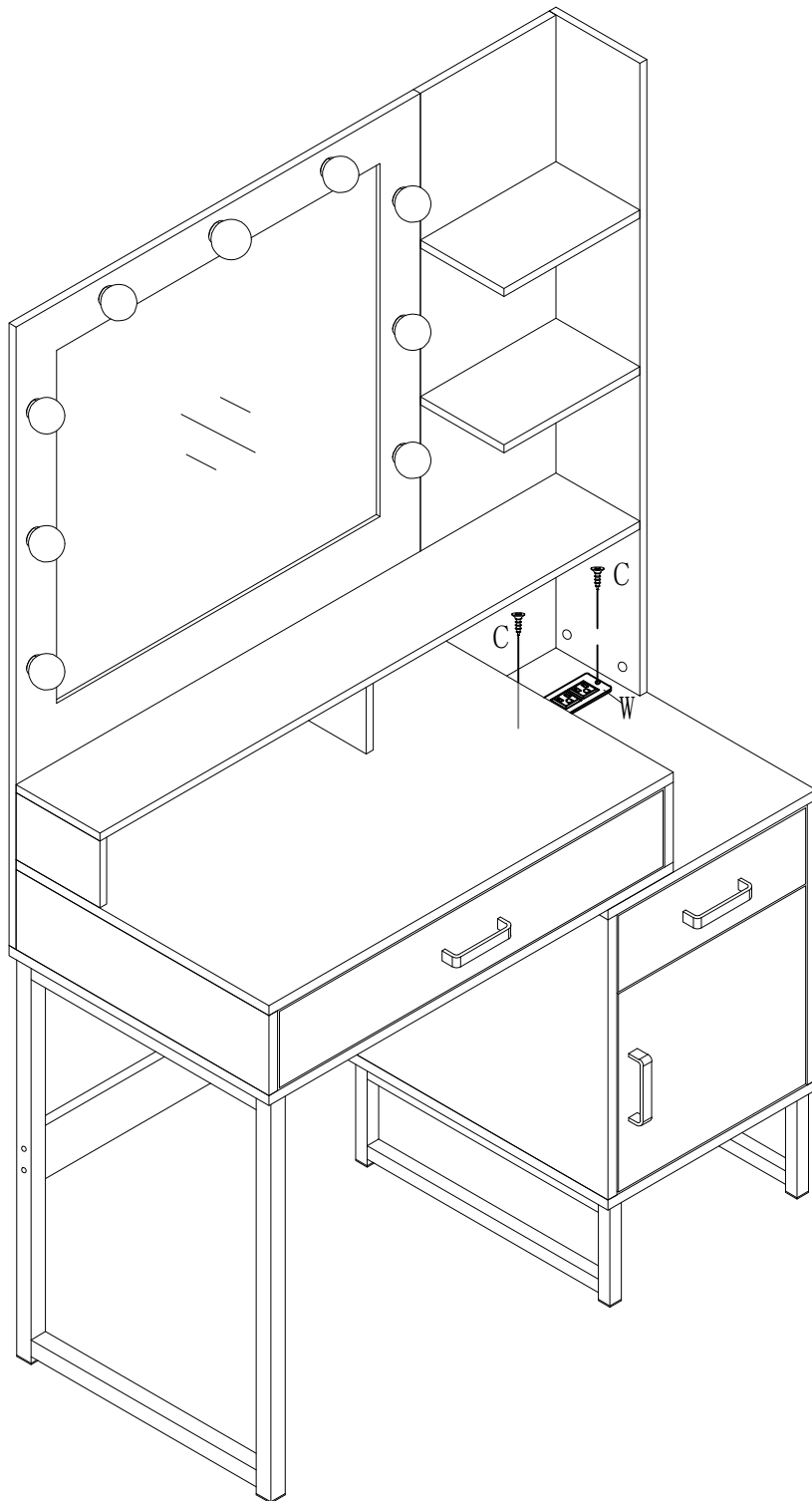

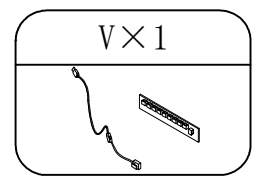

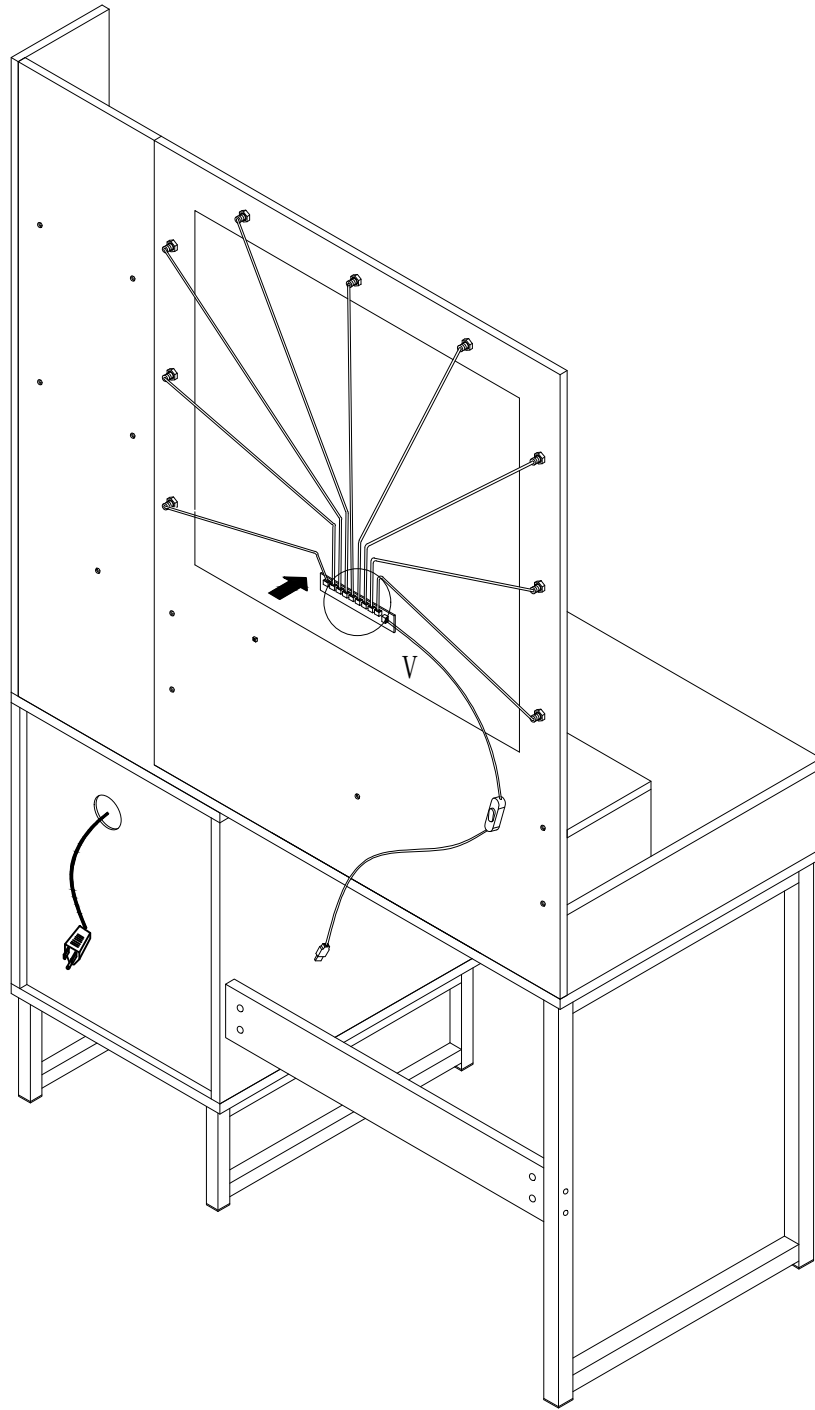
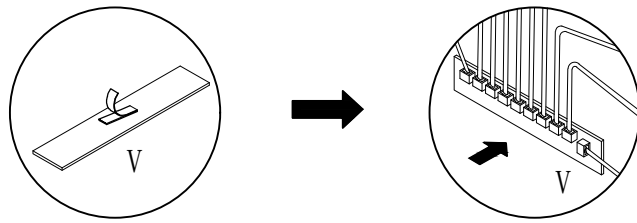

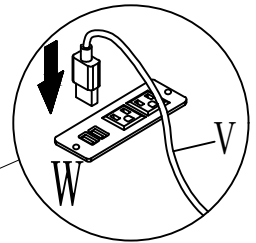
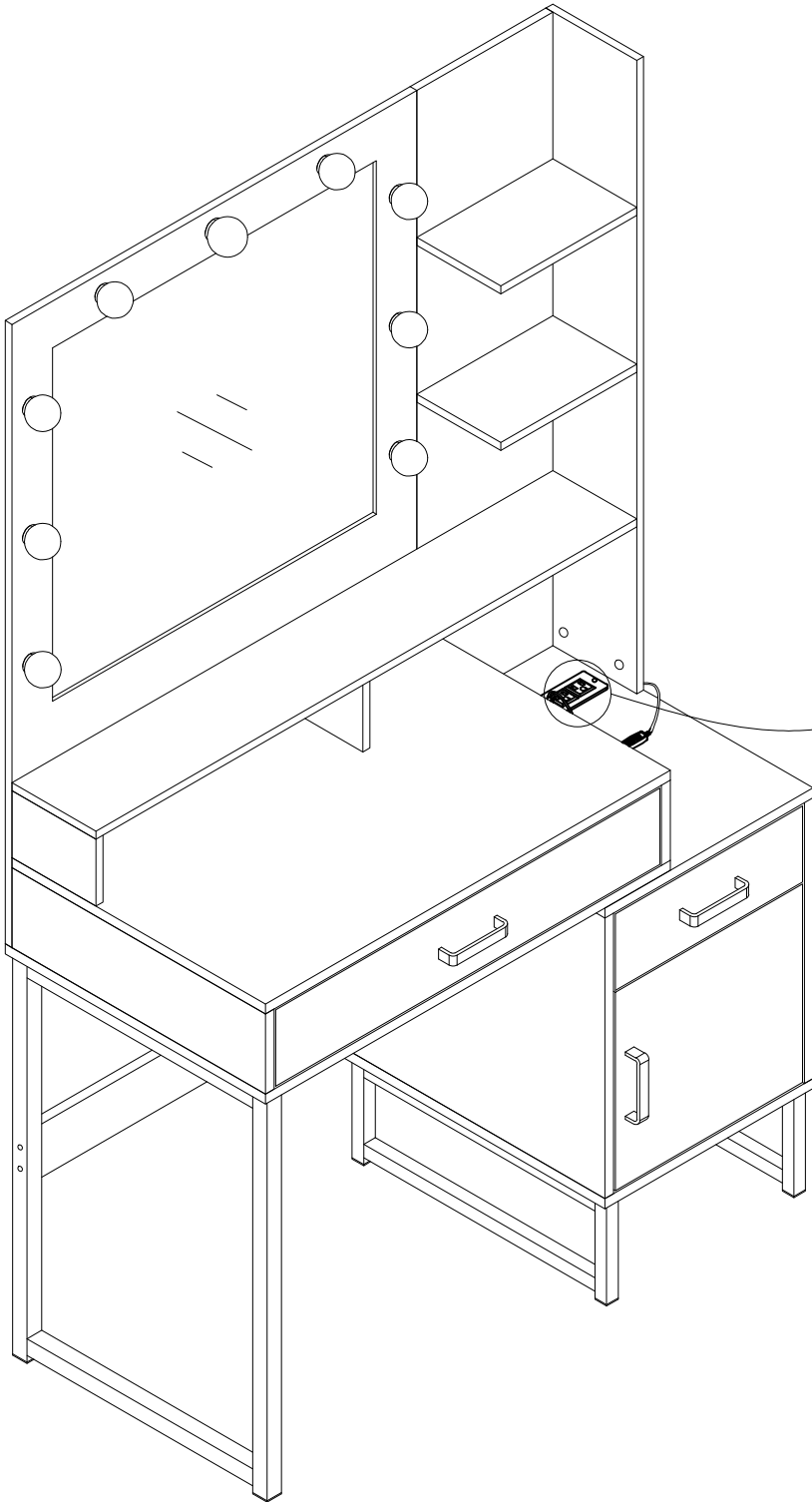

36

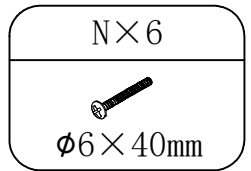
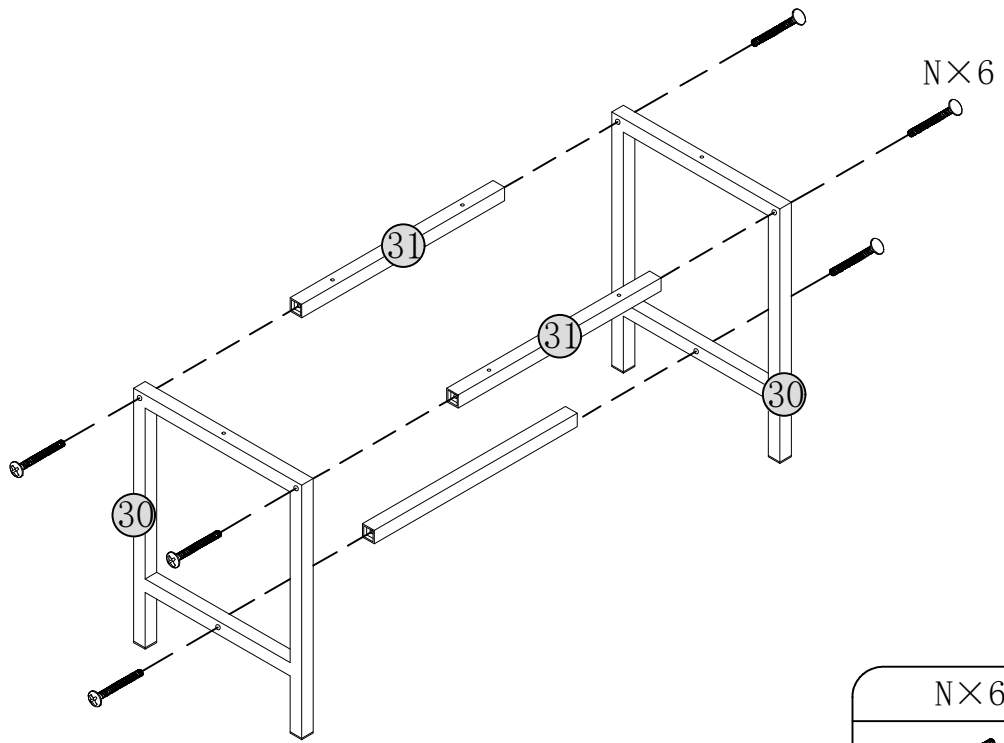

37

