

ASSEMBLY INSTRUCTION

SIDE CHAIR WITH METAL LEGS

A Front Leg

B Back Leg

C Seat

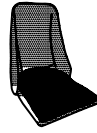
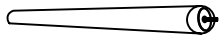

2PCS

2PCS

1PC

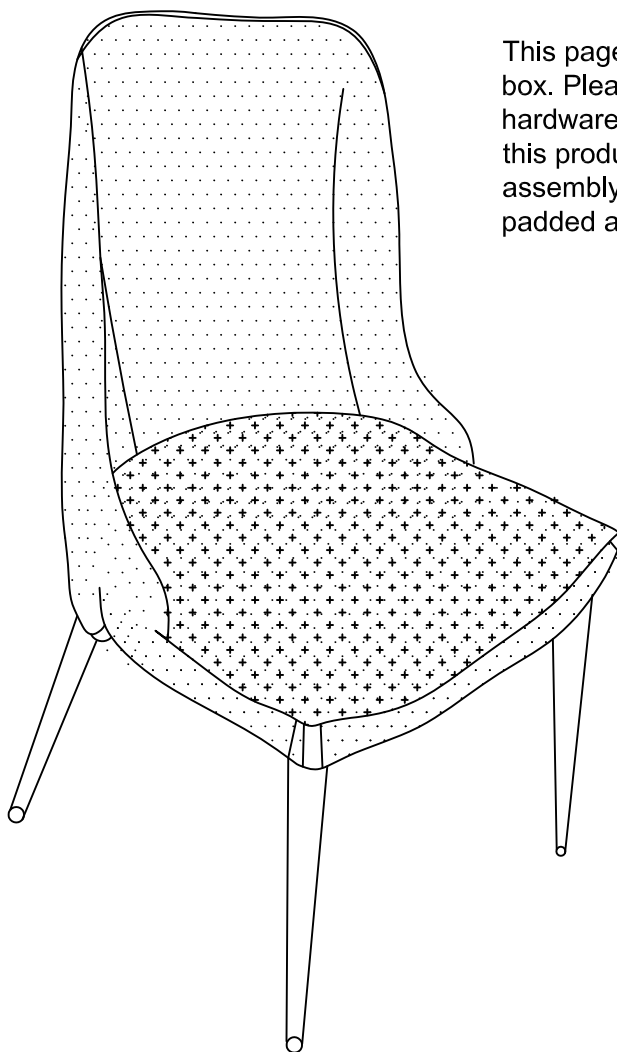

This page lists all the contents included in the box. Please take the time to identify the hardware as well as the individual components to this product. As you unpack and prepare for assembly, place the contents on a carpeted or padded area to protect them from damage.

-
- 1** Spin the Front Leg (A) into the pre-drilled hole of the Seat (C) as shown below. Use same method to assemble another Front Leg (A) and 2 Back Leg (B).

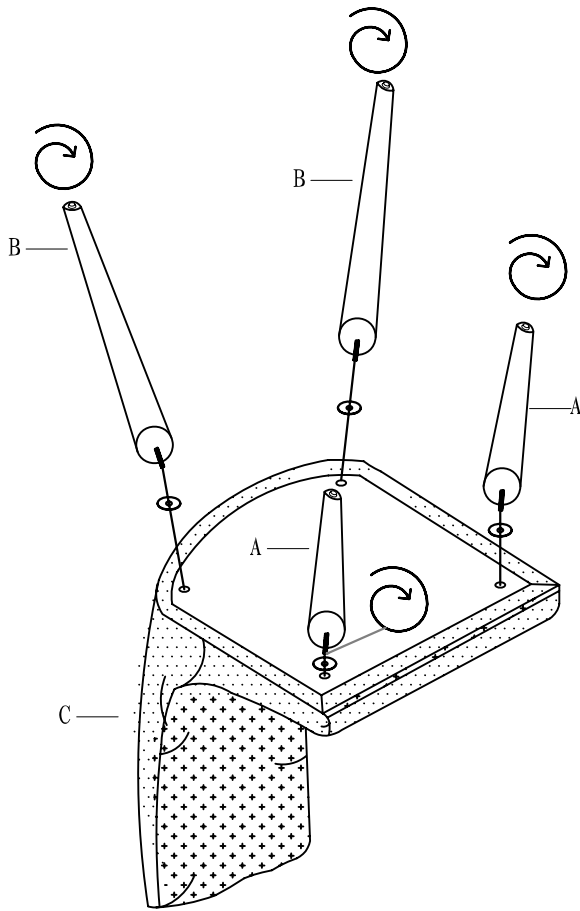

DO NOT TIGHTEN COMPLETELY. Stop when you feel you are adding force to tighten the bolt.

Helpful Tip:

- Instead of applying downward pressure while reaching under to tighten bolts, have someone sit on the chair while you tighten the bolts.

Stand chair up on an even surface and check that it is balanced.
If there is a slight wobble, apply downward pressure in the corner where a leg is uneven. Keeping pressure in that corner, tighten all bolts. If balanced, apply downward pressure evenly in the center and tighten all bolts. Do not over-tighten beyond hole depth.

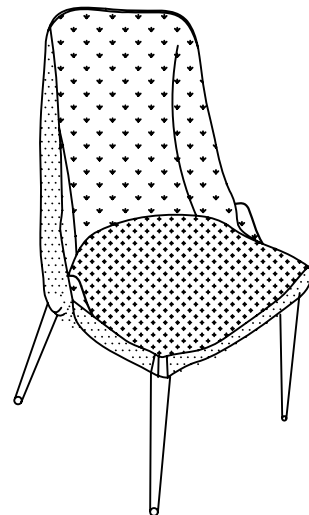

Cleaning & Care

Treat surface with care. Surface is resistant to scratches but is not scratch resistant. Clean surfaces with a dry or damp soft cloth. Do not use abrasive cleaners. Hardware may loosen over time. Periodically check that all connections are tight.