

NOTICE

This product is a wooden furniture made of various materials such as solid wood.

*Please make sure that you have all parts indicated before you begin assembly of this item.

*This item should be assembled on a soft surface to prevent scratching the finish during assembly.

*This item may require periodic tightening.

*Before you start assembling this product, please make sure you have all the parts indicated. Make sure that the furniture is assembled in the correct position and tightened, does the appearance, shape and color of the product meet the requirements.









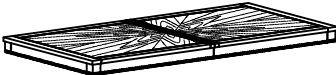

*This product should be assembled on a soft surface to prevent scratching the surface during assembly.

CARE AND MAINTENANCE

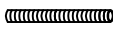
Cleaning should be done with a soft lint free cotton cloth dampened with water or furniture polish.

On highly used surfaces we recommend applying a quality paste wax which should be used on a regular basis to provide additional protection from scratches and spills. How often you apply the wax depends on how much wear the furniture receives.

Part List and Hardware List

| PIECE | DESCRIPTION | PICTURE | QUANTITY |
|-------|-------------------------------|---|----------|
| A | Tensile table top |  | 1 |
| B | Mid Table top |  | 1 |
| C | Base frame |  | 2 |
| D | Brace |  | 1 |
| H1 | Full tooth screw (M8*70) |  | 2 |
| H2 | Half-moon pad (M8) |  | 2 |
| H3 | Hexagon nuts (M8) |  | 2 |
| H4 | Hexagon socket screws (M8*55) |  | 4 |
| H5 | Disk washer (M8*17) |  | 4 |
| H6 | Open-end wrench |  | 1 |
| H7 | Allen Key |  | 1 |

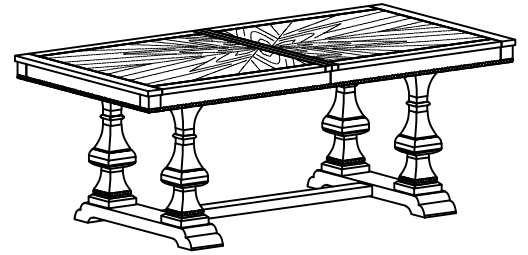

ITEM: CZ-5027#

Product Dimensions: 74"Wx35.4"Dx30"H

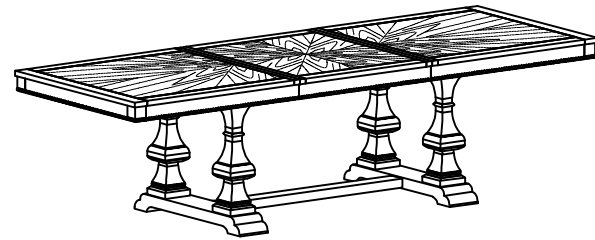

ITEM: CZ-5027# (Additional middle table top)
Product Dimensions: 105.5"Wx35.4"Dx30"H

PREPARATION

Before beginning assembly of product. Make sure all parts are present. Compare parts with package contents list and hardware contents list.

If any part is missing or damaged, do not attempt to assemble the product

Estimated Assembly Time: 10 minutes

Tools required for assembly (included): Allen Key

H4+H5: Connecting Hexagon socket screw to disk washer

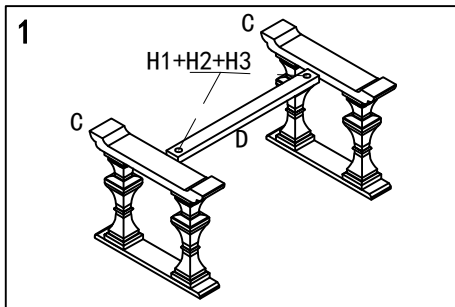

Step 1

Take out the 2 base frames (C) and brace (D) from the box, install the full-threaded screws (H1) in the two holes on the side of the base frames (C), insert the brace (D), and then fix it with the half-moon pad plus the hexagonal nut.

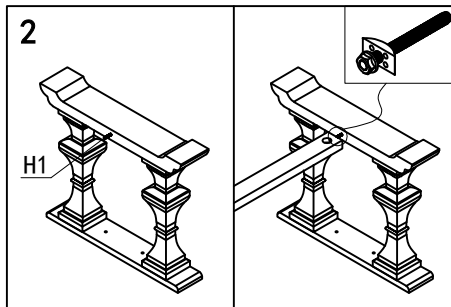

Step 2

(H1+H2+H3) Installation as shown

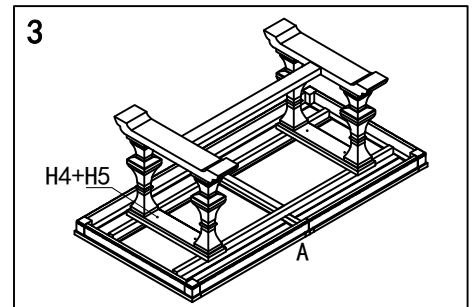

Step 3

Take the tensile table top (A) out of the box, place the mounted base frame (C) upside down on the back of the table top (A), and tighten with (H4+H5) by turning clockwise until firm.

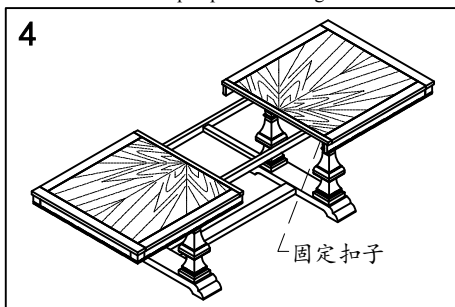

Step 4

Turn on the retaining switch underneath the table top (A) and pull the table top away from the sides.

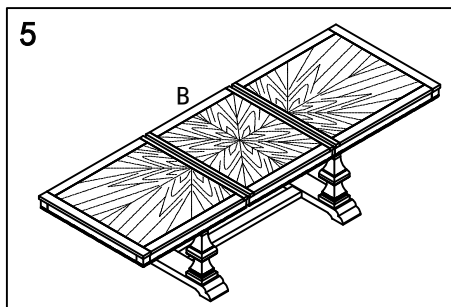

Step 5

Place in mid table top (B)

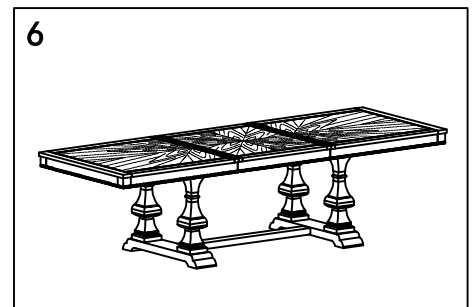

Step 6

Push both sides of the table top inward to tighten the fasteners retaining switch under the table top.