

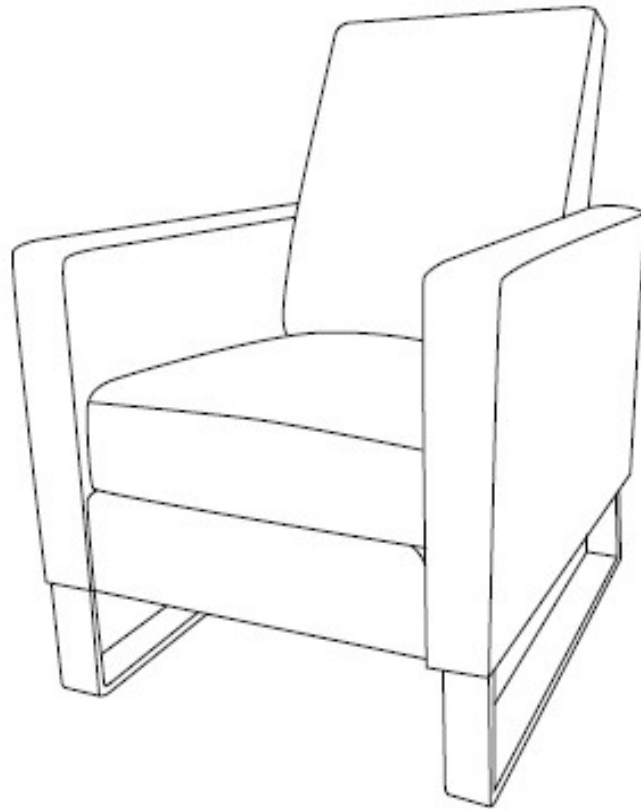



Assembly Instructions

Caution : You must read this before you proceed



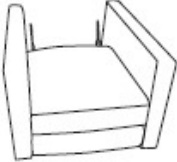

RECLINER











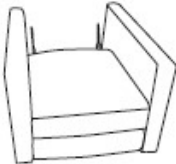

Parts List

Label	Picture	Description	QTY
A		Chair Backrest	1
B		Chair Base Body	1
C		Leg	2

Hardware

Label	Picture	Description	QTY
①		Bolt(M8*25mm)	9
②		Spring Washer	9
③		Flat Washer	9
④		Allen Key	1
⑤		Magic Sticker (Just for spare)	3

Assembly Preparation

<p>Before Beginning Assembly:</p>	   	 X9  X9  X9  X1	  
-----------------------------------	---	---	---



- Read instructions, cover to cover-



- Have 2 adults on hand for assembly-



- Do not assemble on flooring or carpet-



- Assemble on a clean non-marring surface (packing foam)-



- Save all packaging until finished-

Assembly Steps

OVERVIEW

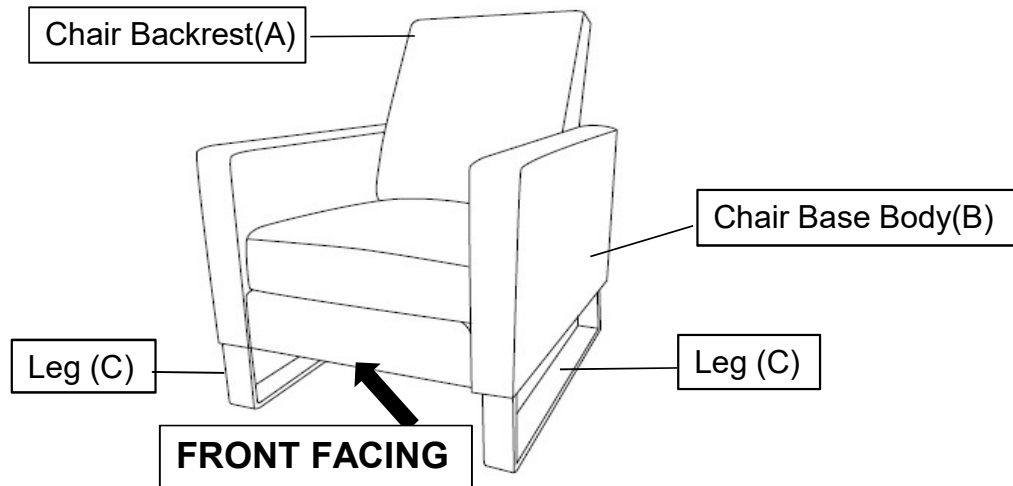

This Recliner has multiple parts and may require up to 30 minutes to assemble. To give you an overview of the Recliner parts, the above picture is to help you put the various Recliner parts into perspective. Please read through the instructions to familiarise yourself with the parts and steps before assembly.

Step 1

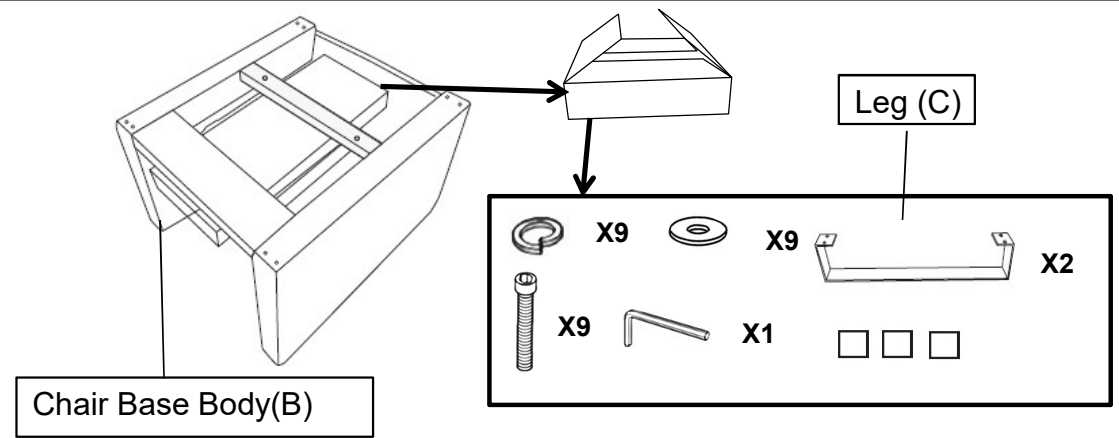

Position the Chair Base Body(B) as shown.
(Perferrably on a surface that won't scratch the upholstery.)
Open the inner box and take out the 2 steel legs and Hardware provided.

Step 2

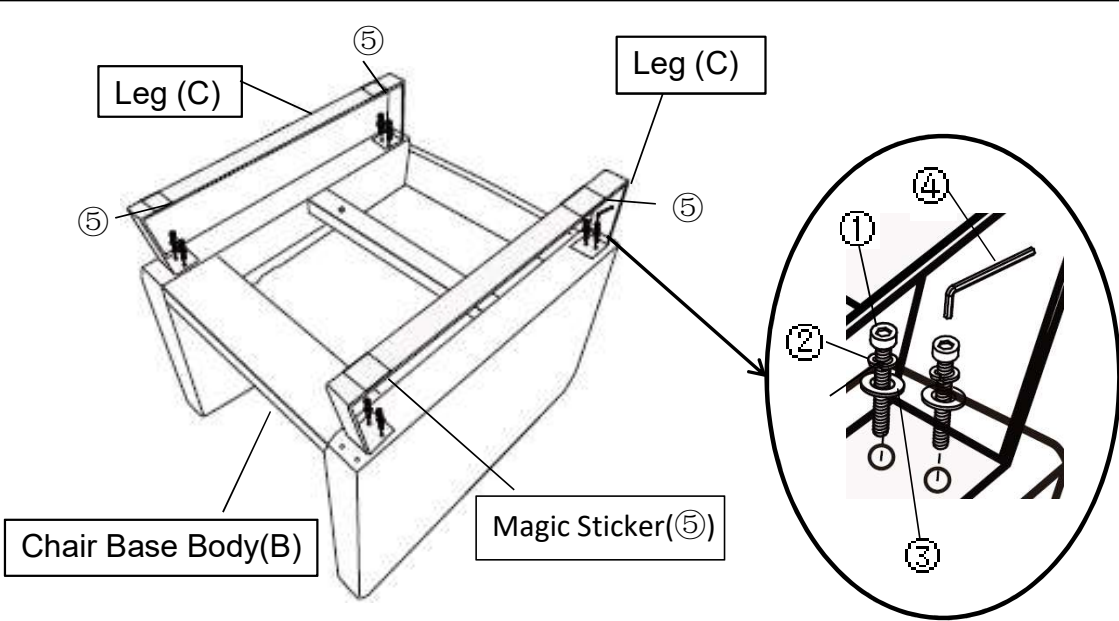

Place the Chair base(B) on its back.

Align the mounting position of the Leg(C) and the chair base(B) firmly and gently.

Turn the flat washer(③). Spring washer(②). Bolt(①) to the mounting position of the Chair base(B) clockwise. Repeat the same steps to install the Leg(C).

NOTE: You will find there are Magic Sticker(⑤) on the Leg (C), besides that there are 3 pcs Magic Sticker(⑤) in the hardware package, this 3 pcs Magic Sticker(⑤) just for spare.

Step 3

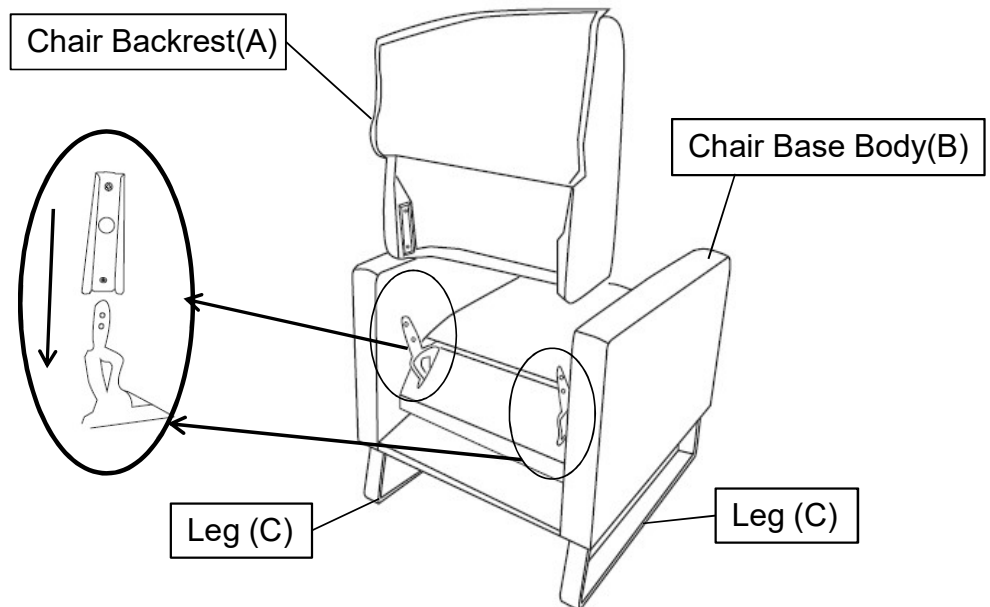

Chair Backrest(A) socket is aligned with the mounting position on the Chair Base Body(B), and the Chair Backrest(A) is firmly but gently pushed down until the Chair Backrest (A) is fully grooved and locked in place.

Step 4

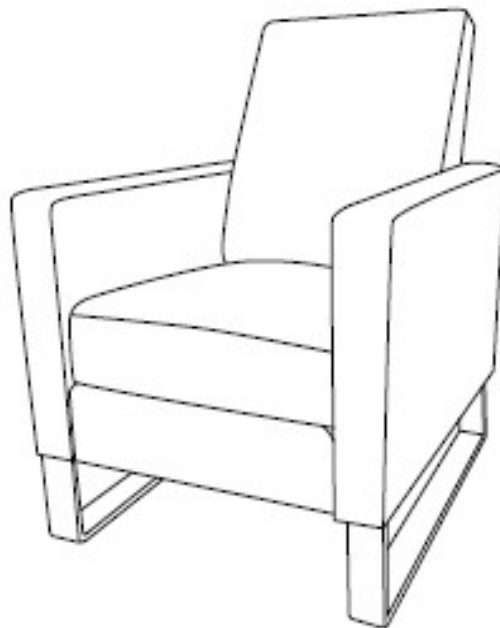

Your Recliner is ready for use.

Caution :This Recliner can only be used on a flat, level surface.

User Instructions.

Recliner Chair

Please read the Instruction Manual below carefully before use.

This is a Recliner Chair. At anytime in a reclined seat position or in the upright position. You may enjoy the rocking motion by using your body weight in a back-front rocking motion.

Supervise children, when in use of this Recliner.

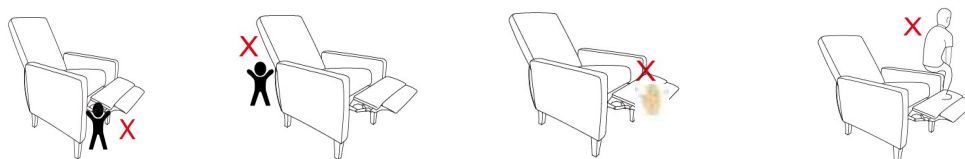

Do not let children stand in front of or behind the Push Back Chair when opening or closing the footrest. Do not put your hands inside the Footrest when opening or closing the footrest. Do not sit any armrest of this Push Back Chair.

To get into a reclined posture - To Recline backrest

Sit into the seat.

Place your feet apart .

Place your left and right arm onto the armrest.

Synchronise a backward push with your arms.

Use your body weight and push backwards into the seat into a fully reclined position.

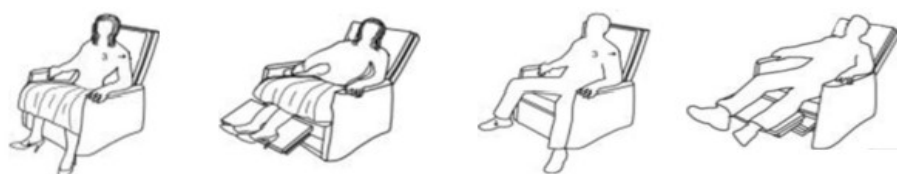

To get out of chair - move Seatback into Upright Position







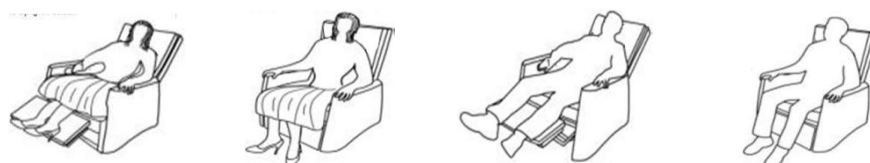











Tilt your body weight slightly forward and upwards.

The seat back will come up to an upright position.

Where necessary, use either your arms help lift- push yourself out of the seat.



Care & Maintenance

-   ● Do not put hot items directly on furniture surface
-   ● Do not clean furniture with harsh cleansers or polish.
-   ● Do not place furniture under direct sunlight.
-   ● Do not place furniture near heating or cooling vents.
-   ● Do not write on furniture without a padded barrier to protect the surface.
-   ● Do not place furniture outside . For indoor use only .
-   ● Not for commercial use. For residential use only .
-   ● Stains may be removed with mild soap solution and damp cloth.
-   ● Children should not climb or jump on the furniture.

-
-   ● Dust and pick-up spills using a clean, non-colored, lint-free cloth .

Questions & Answers about Proposition 65

• What is Proposition 65?

Proposition 65 requires businesses to provide warnings to Californians about significant exposures to chemicals that cause cancer, birth defects or other reproductive harm. These chemicals can be in the products that Californians purchase, in their homes or workplaces, or that are released into the environment. By requiring that this information be provided, Proposition 65 enables Californians to make informed decisions about their exposures to these chemicals.

Proposition 65 also prohibits California businesses from knowingly discharging significant amounts of listed chemicals into sources of drinking water.

Proposition 65 requires California to publish a list of chemicals known to cause cancer, birth defects or other reproductive harm. This list, which must be updated at least once a year, has grown to include approximately 900 chemicals since it was first published in 1987.

• What types of chemicals are on the Proposition 65 list?

The list contains a wide range of naturally occurring and synthetic chemicals that include additives or ingredients in pesticides, common household products, food, drugs, dyes, or solvents. Listed chemicals may also be used in manufacturing and construction, or they may be byproducts of chemical processes, such as motor vehicle exhaust.

• What does a warning mean?

If a warning is placed on a product label or posted or distributed at a workplace, a business, or in rental housing, the business issuing the warning is aware or believes that it is exposing individuals to one or more listed chemicals.

By law, a warning must be given for listed chemicals unless the exposure is low enough to pose no significant risk of cancer or is significantly below levels observed to cause birth defects or other reproductive harm.

• Where can I get more information on Proposition 65?

If you have specific questions on the administration or implementation of Proposition 65, you can contact OEHHA's Proposition 65 program at P65.Questions@oehha.ca.gov, or by phone at (916) 445-6900.