

Product Installation Steps

To give full play to the product's performance, please install and use it correctly according to the manual.

1. Refer to the installation completion drawing for the installation position of the armrests.

2. Install the armrests in a position where they will not get caught with surrounding walls and other utensils.

3. Test the armrests after installation is completed.

4. The surface of the armrests is difficult to repair if damaged, so please protect them carefully after completion.

Product Configuration Standards

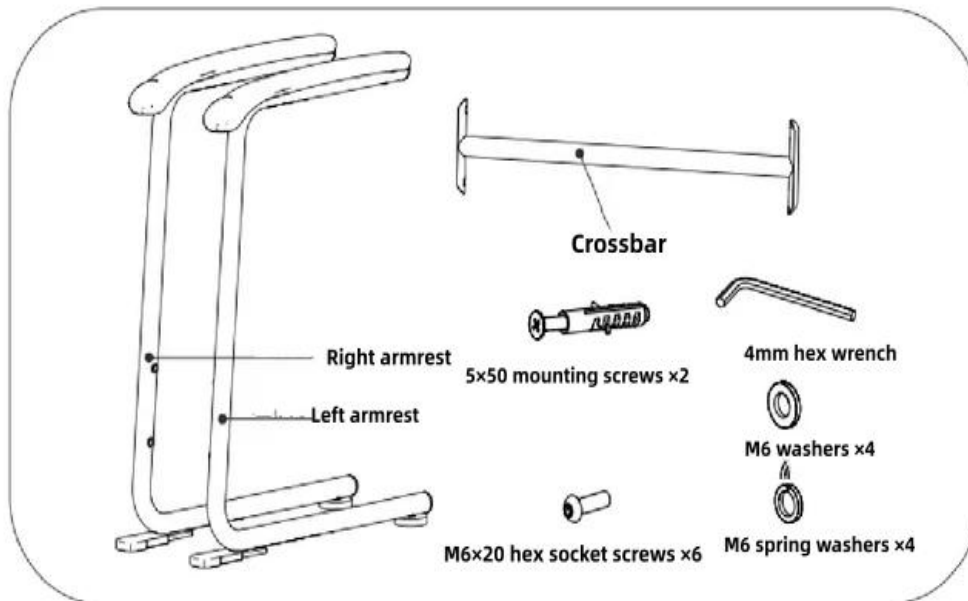

Product Installation Steps



1. Align the crossbar holes with the armrest holes.

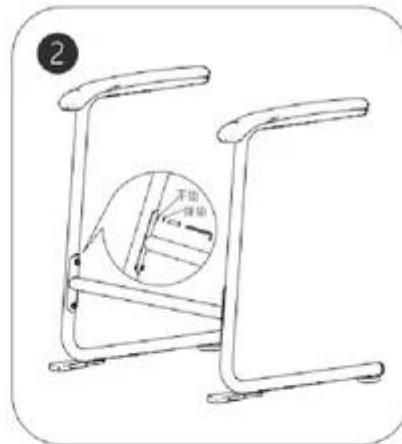

2. Align the four holes of the armrest and crossbar, then tighten the M6x20 hex socket screws with a wrench.

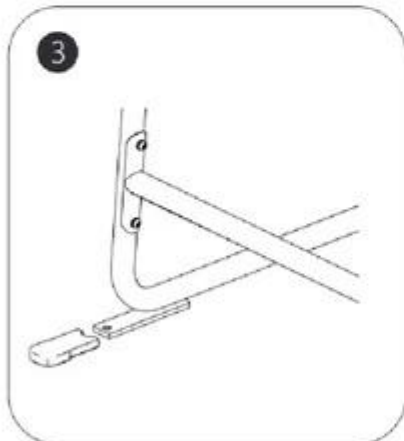

3. If fixing to the ground, remove the leg cover from the armrest, mark the appropriate position on the ground with a marker pen on the armrest base plate.

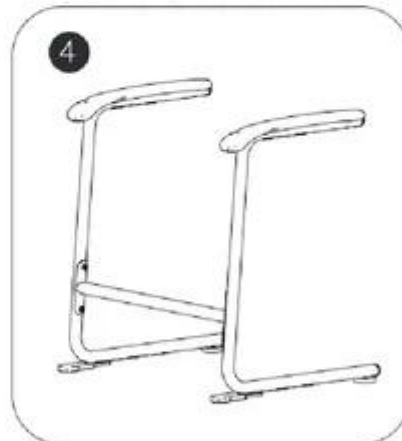

4. Drill holes at the marked positions with a hand drill, insert expansion tubes, and tighten the mounting screws.

After Installation, Check and Confirm the Following Items

1. Check if the product is loose. If loose, reinstall it according to the installation steps.
2. Check if the product is firmly installed. If not, inspect each part one by one and retighten.