

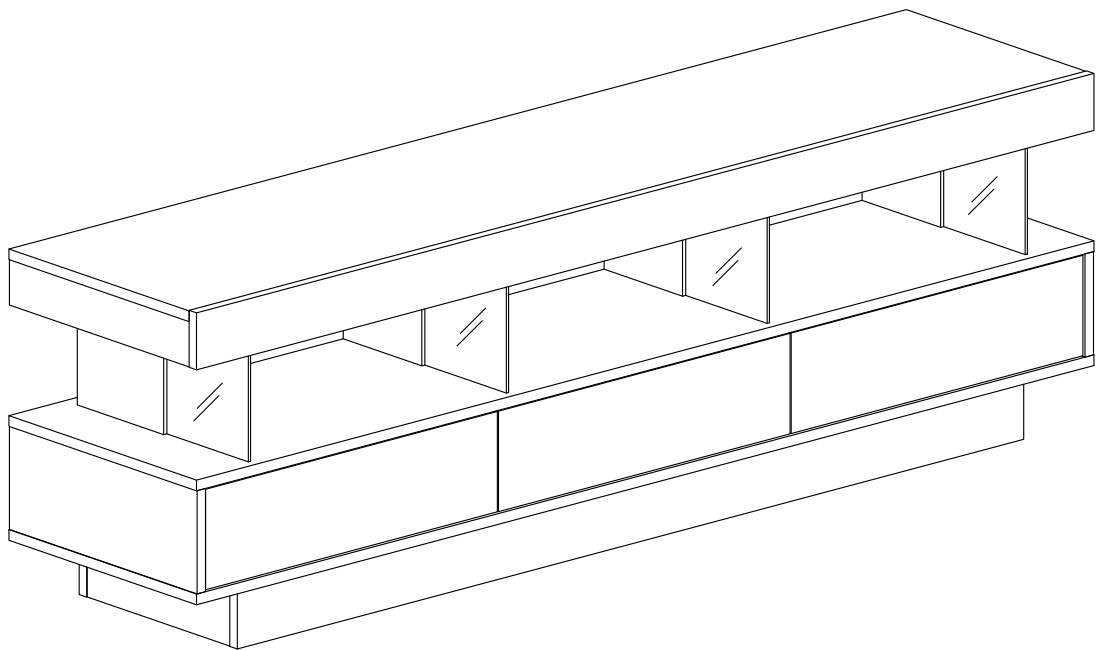





Product manual

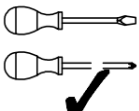

Our product will be delivered to you in 2 packages. The delivery times of these 2 packages may differ, please be patient and thank you for your understanding.

 2PERS	 45MIN	Tool Required Not Provided	
			

Conseils de sécurité et d'entretien

Important - Veuillez lire entièrement ces instructions avant de commencer l'assemblage

Attention : cet appareil est relativement lourd. Veuillez soulever avec précaution. Vérifiez que vous disposez de tous les composants et outils répertoriés sur les pages.

Retirez tous les raccords des sacs en plastique et séparez-les en groupes.

Gardez les enfants et les animaux éloignés de la zone de travail, les petites pièces pourraient s'étouffer en cas d'ingestion. Les pièces de l'assemblage seront plus faciles à 2 personnes.

Assurez-vous de disposer de suffisamment d'espace pour disposer les pièces avant de commencer. Ne vous tenez pas debout et ne mettez pas de poids sur le produit, cela pourrait l'endommager.

Assemblez l'objet le plus près possible de sa position finale dans la même pièce.

Assemblez sur une surface douce pour éviter d'endommager l'unité ou votre sol, utilisez le carton de l'unité ouvert.

Entretien et maintenance

Nettoyez uniquement à l'aide d'un chiffon humide et d'un détergent doux, n'utilisez pas d'eau de Javel ni de nettoyeurs abrasifs. Vérifiez de temps en temps qu'il n'y a pas de vis desserrées sur cet appareil.

(Note)

Si nécessaire, la page suivante peut être découpée et utilisée comme référence tout au long de l'assemblage.

Conservez cette page avec ces instructions pour référence future du manuel du produit.

Ce produit se compose de 2 colis logistiques, veuillez vérifier le numéro de vos colis, s'il en manque, veuillez contacter la logistique.

Veuillez lire toutes les précautions et instructions de ce manuel avant d'utiliser ce produit.

Si vous avez des questions sur ce produit, veuillez contacter votre fournisseur à temps.



Safety and Care Advice

Important - Please read these instructions fully before starting assembly

Warning: This unit is relatively heavy. Please lift with care. Check you have all the components and tools listed on pages.

Remove all fittings from the plastic bags and separate them into their groups.

Keep children and animals away from the work area, small parts could choke if swallowed. Parts of the assembly will be easier with 2 people.

Make sure you have enough space to layout the parts before starting. Do not stand or put weight on the product, this could cause damage.

Assemble the item as close as possible to its final position in the same room.

Assemble on a soft level surface to avoid damaging the unit or your floor use opened out unit carton.

Care and maintenance

Only clean using a damp cloth and mild detergent, do not use bleach or abrasive cleaners. From time to time check that there are no loose screws on this unit.

(Note)

If required the next page can be cut out and used as reference throughout the assembly.

Keep this page with these instructions for future reference Product Manual.

Please read all precautions and instructions in this manual before using this product.

If you have any questions about this product, please contact your supplier in time.

Conseils de sécurité et d'entretien

Important - Veuillez lire entièrement ces instructions avant de commencer l'assemblage

Attention : cet appareil est relativement lourd. Veuillez soulever avec précaution. Vérifiez que vous disposez de tous les composants et outils répertoriés sur les pages.

Retirez tous les raccords des sacs en plastique et séparez-les en groupes.

Gardez les enfants et les animaux éloignés de la zone de travail, les petites pièces pourraient s'étouffer en cas d'ingestion. Les pièces de l'assemblage seront plus faciles à 2 personnes.

Assurez-vous de disposer de suffisamment d'espace pour disposer les pièces avant de commencer. Ne vous tenez pas debout et ne mettez pas de poids sur le produit, cela pourrait l'endommager.

Assemblez l'objet le plus près possible de sa position finale dans la même pièce.

Assemblez sur une surface douce pour éviter d'endommager l'unité ou votre sol, utilisez le carton de l'unité ouvert.

Entretien et maintenance

Nettoyez uniquement à l'aide d'un chiffon humide et d'un détergent doux, n'utilisez pas d'eau de Javel ni de nettoyeurs abrasifs. Vérifiez de temps en temps qu'il n'y a pas de vis desserrées sur cet appareil.

(Note)

Si nécessaire, la page suivante peut être découpée et utilisée comme référence tout au long de l'assemblage.

Conservez cette page avec ces instructions pour référence future du manuel du produit.

Veuillez lire toutes les précautions et instructions de ce manuel avant d'utiliser ce produit.

Si vous avez des questions sur ce produit, veuillez contacter votre fournisseur à temps.



EN_QUICKFIT: Tighten quickfit until shoulder is flush with panel. Do not overtighten or undertighten.

FR_RACCORD RAPIDE: Faites serrer le raccord rapide jusqu'à ce que l'épaulement soit parfaitement encastré dans le panneau. Il ne faut ni trop serrer ni insuffisamment serrer.

ES_QUICKFIT: Apriete quickfit hasta que el hombro se descargue con el panel. NO lo sobreapriete ni lo apriete poco.

DE_QUICKFIT: Ziehen Sie den Quickfit fest, bis die Schulter mit der Platte bündig ist. Bitte nicht zu fest oder zu schwach anziehen.

IT_MONTAGGIO RAPIDO: Stringere il montaggio rapido fino a quando la spalla è a filo con il pannello, non stringere troppo o troppo poco.

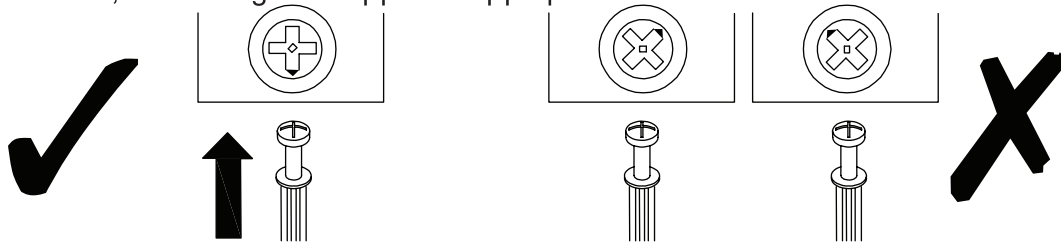

EN_CAM LOCK: When fitting cam lock, ensure starting position is correct before you insert connecting quickfit.

FR_SERRURE BATTEUSE: Avant d'insérer la serrure batteuse, veillez à la bonne orientation avant d'insérer le raccord rapide.

ES_CIERRE DE LA CÁMARA: Cuando instale el cierre de la cámara, asegúrese de que la posición de inicio es correcta antes de que inserte el quickfit conector.

DE_CAM-LOCK: Achten Sie bei der Montage des Cam-Locks auf die richtige Ausgangsposition, bevor Sie den Quickfit einsetzen.

IT_BLOCCAGGIO A CAMMA: Quando si monta il bloccaggio a camma, assicurarsi che la posizione iniziale sia corretta prima di inserire il montaggio rapido di collegamento.



EN_Quickfit head should be in the centre of the cam lock when the two panels are joined.

Cam lock should be inserted before quickfit.

FR_Lorsque les deux panneaux sont assemblés, la tête du raccord rapide doit reposer au centre de la serrure batteuse. Il faut insérer la serrure batteuse avant le raccord rapide.

ES_El cabezal del quickfit debe estar en el centro del cierre de la cámara cuando se unan los dos paneles.

Se debe insertar el cierre de la cámara antes que el quickfit.

DE_Der Quickfit-Kopf sollte sich in der Mitte des Cam-Locks befinden, wenn die beiden Platten zusammengefügt sind. Der Cam-Lock sollte vor dem Quickfit eingesetzt werden.

IT_La testa del montaggio rapido deve trovarsi al centro del bloccaggio a camma quando i due pannelli sono uniti.

Il Bloccaggio a Camma deve essere inserito prima del montaggio rapido.

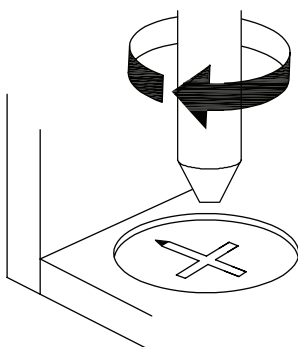

EN_Turn cam lock clockwise to tighten.

FR_Faites tourner la serrure batteuse dans le sens des aiguilles d'une montre pour la resserrer.

ES_Gire el cierre de la cámara en sentido horario para apretarlo.

DE_Drehen Sie den Cam-Lock im Uhrzeigersinn, um ihn festzuziehen.

IT_Ruotare il bloccaggio a camma in senso orario per stringere.

Parts List

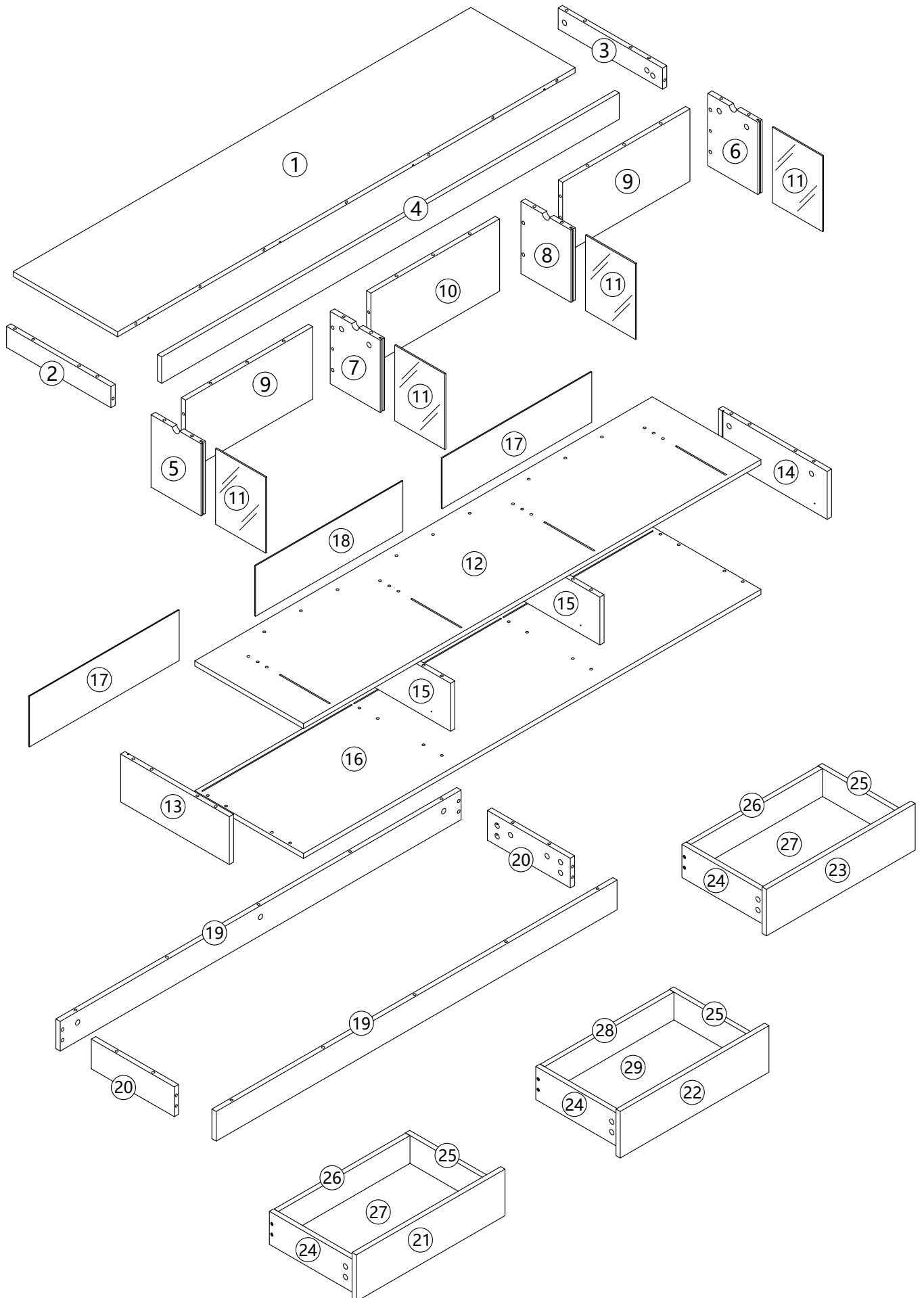



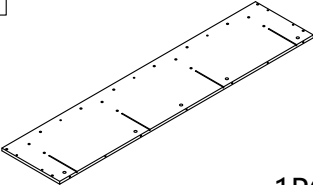
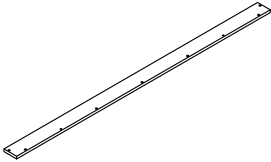
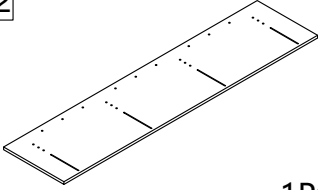
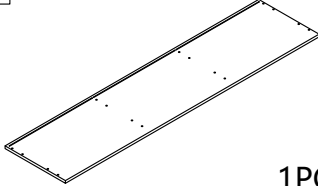
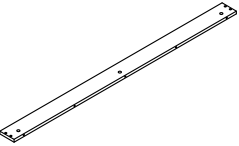

N605P170910

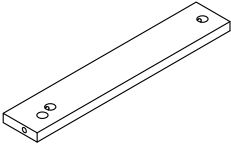
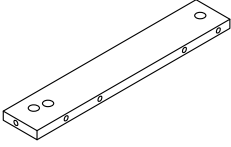
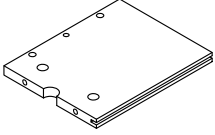
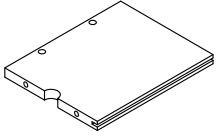
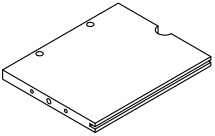
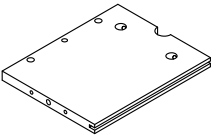
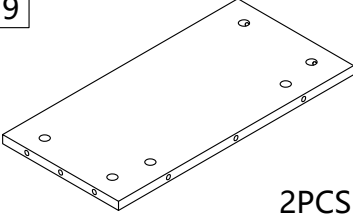
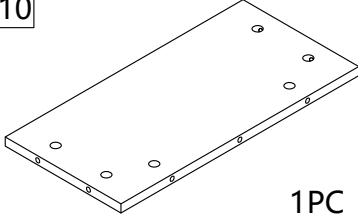
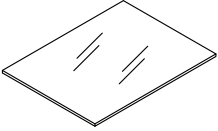
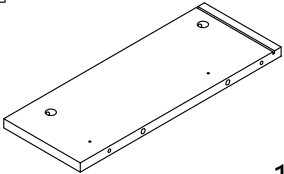
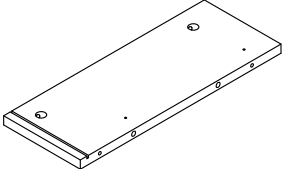
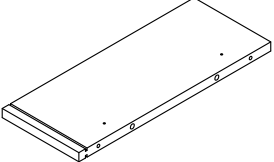
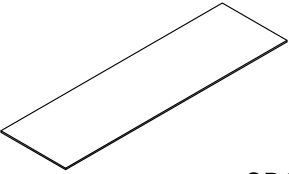
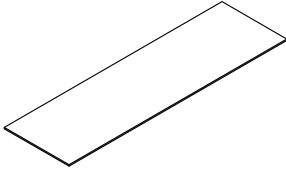
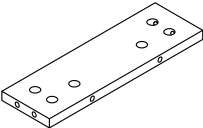
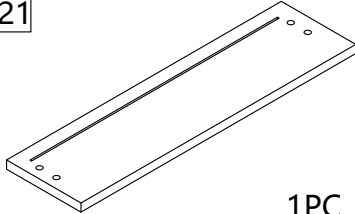
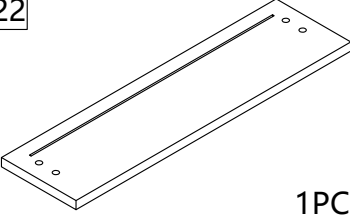
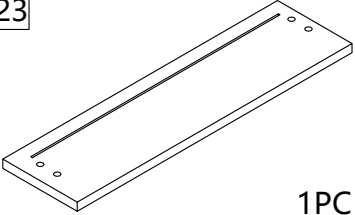
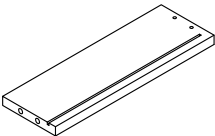
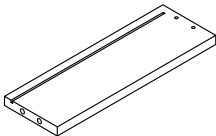
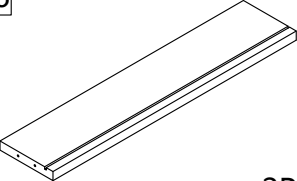
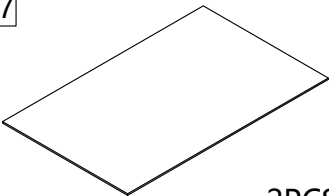
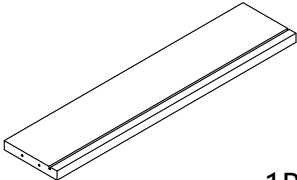
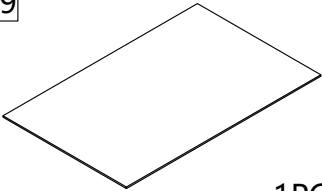
1  1PC	4  1PC	12  1PC	16  1PC
19  2PCS			

N605P170912

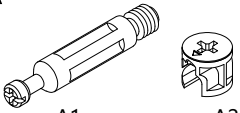
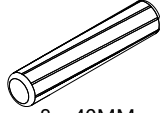
2  1PC	3  1PC	5  1PC	6  1PC
7  1PC	8  1PC	9  2PCS	10  1PC
11  4PCS	13  1PC	14  1PC	15  2PCS
17  2PCS	18  1PC	20  2PCS	21  1PC
22  1PC	23  1PC	24  3PCS	25  3PCS
26  2PCS	27  2PCS	28  1PC	29  1PC

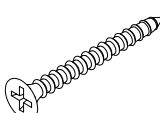
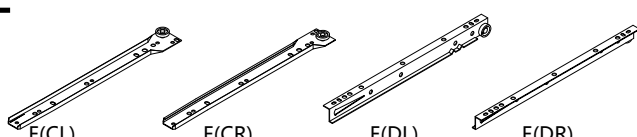
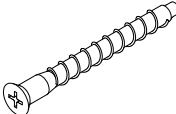
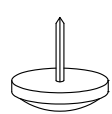
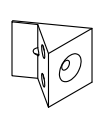
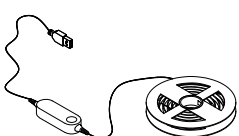
Hardware N605P170912

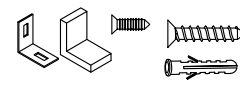
A  A1 A2 75STES	B  8 x 40MM 40PCS	C  3.5 x 14MM 42PCS	D  3.5 x 35MM 12PCS
E  E(CL) E(CR) E(DL) E(DR) 3SETS		F  7 x 50MM 22PCS	G  8PCS
H  12PCS	J J1 J2 3SETS	K  1SET	
L  30PCS	M  2SETS		

1

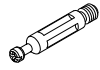

A1 x 12

8 x 40MM



B x 14

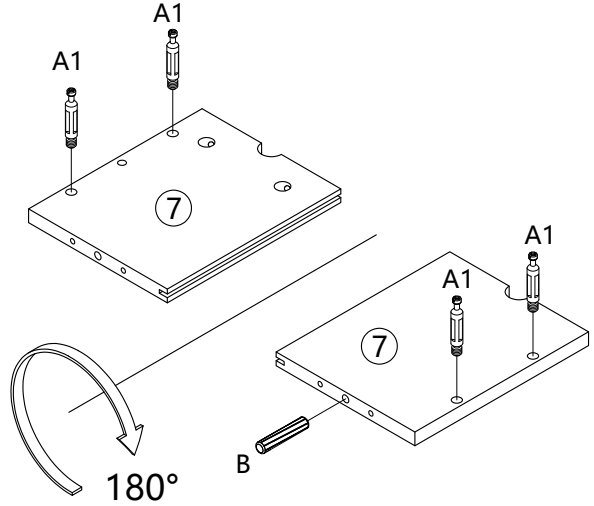
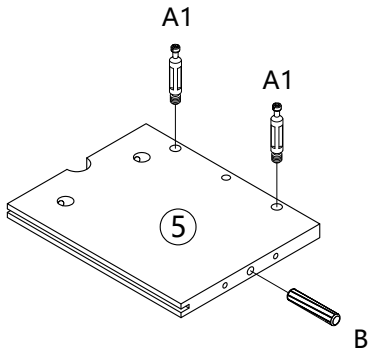

Switch to the other side/
Auf die andere Seite wechseln

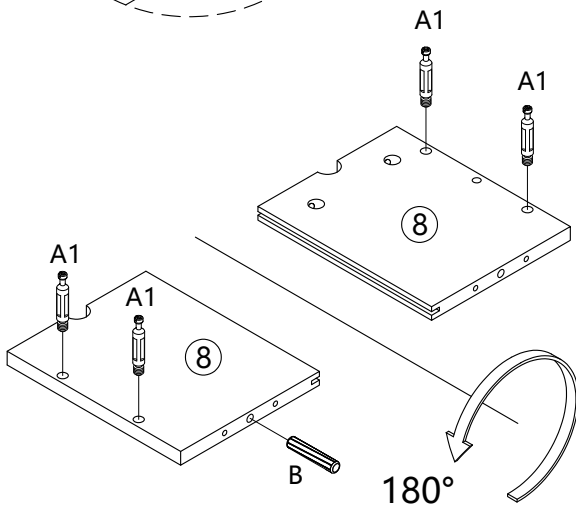
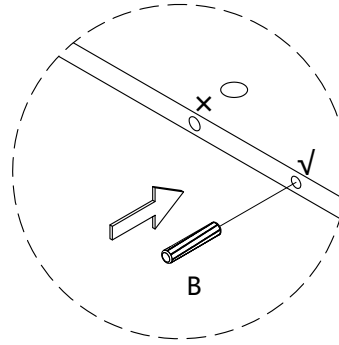
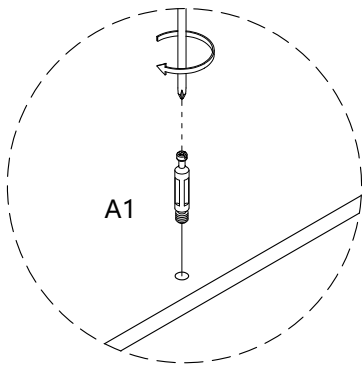

Switch to the other side/
Auf die andere Seite wechseln

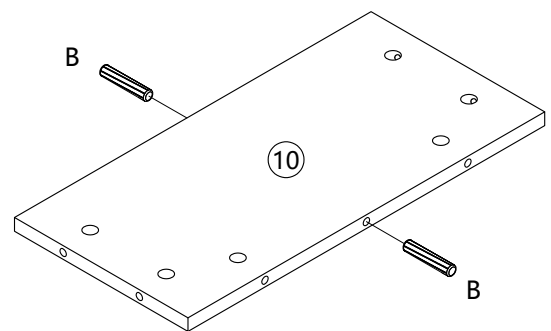
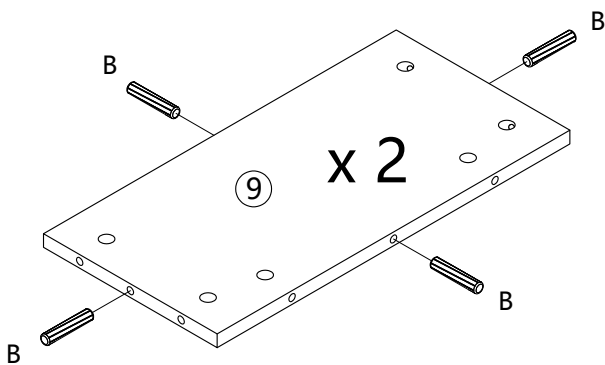
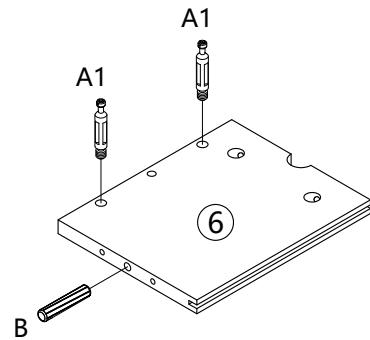

2



A2 x 12

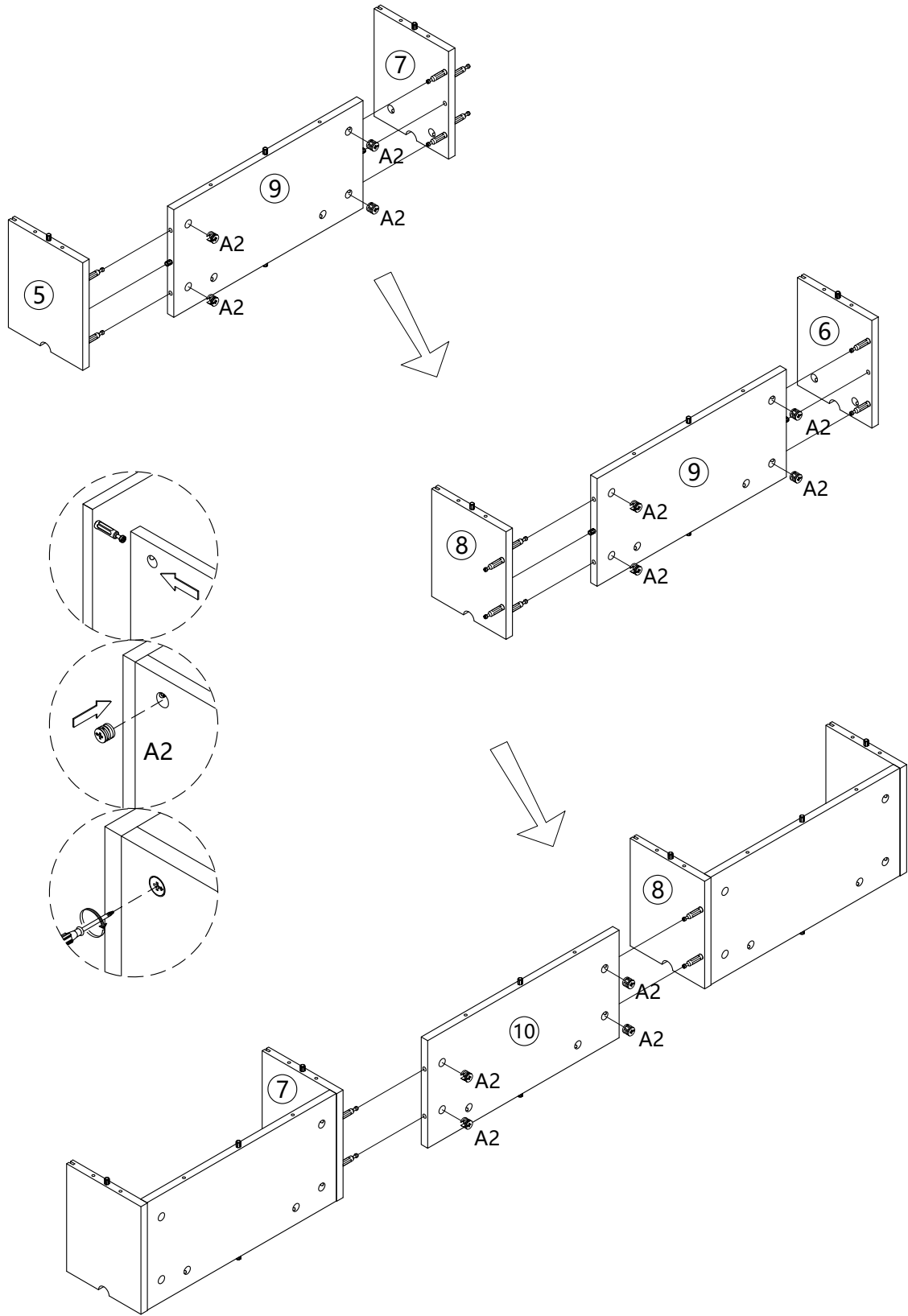

3

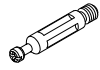

A1 x 8



C x 6



F x 14

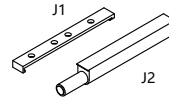

J x 3

3.5 x 14MM

7 x 50MM

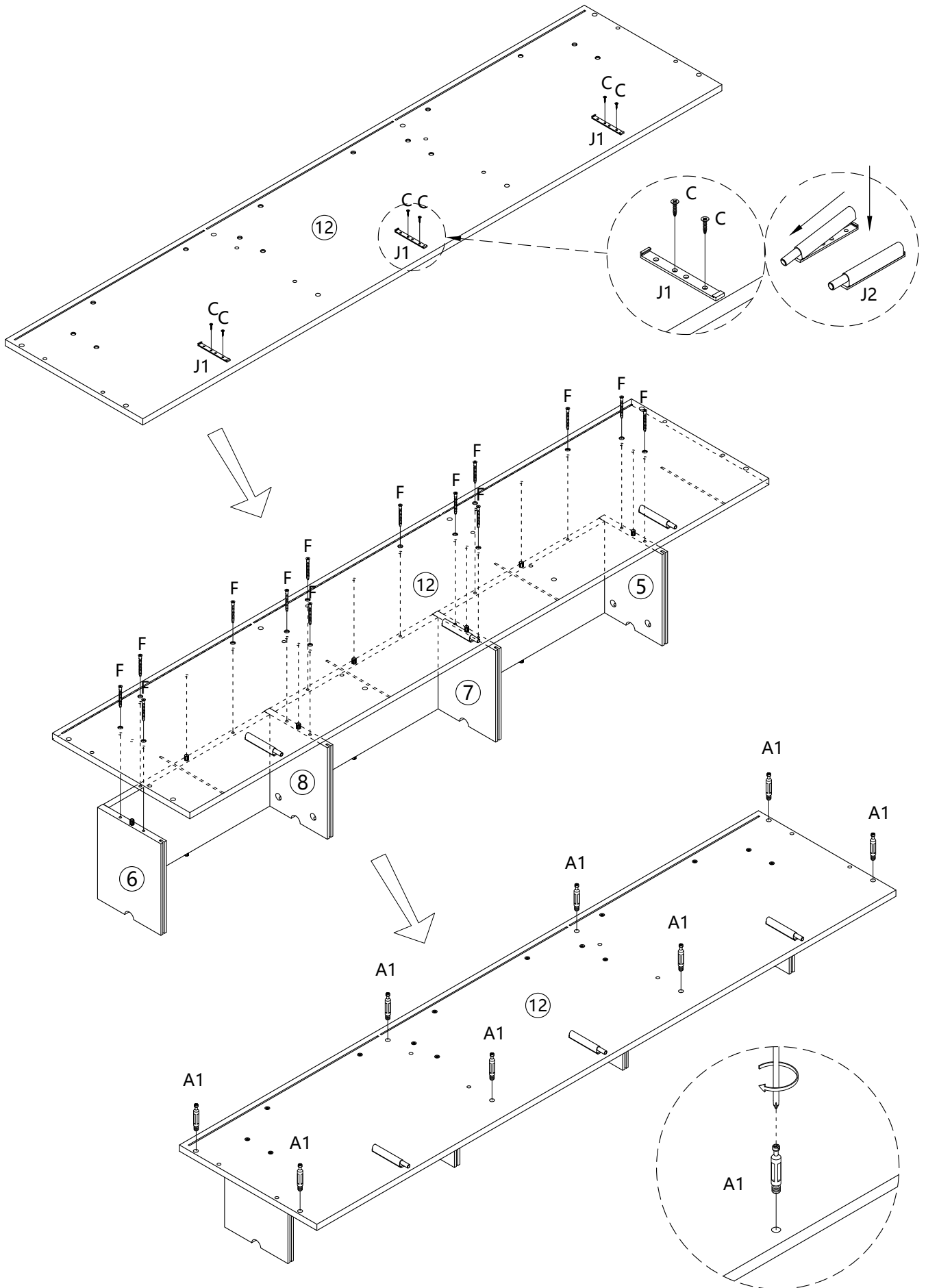

4

8 x 40MM B x 16

3.5 x 14MM C x 12

E(CL) x 3

E(CR) x 3

This side up way/Diese Seite nach oben

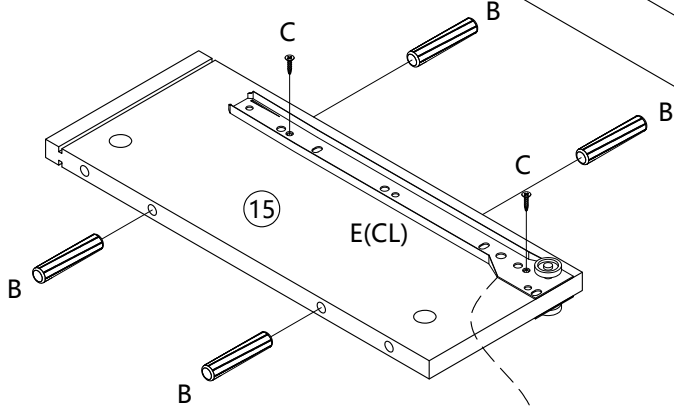
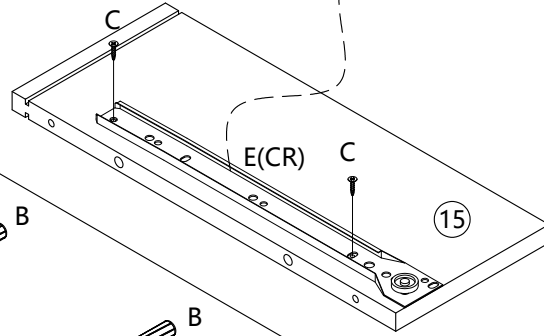
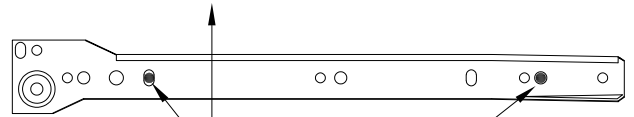
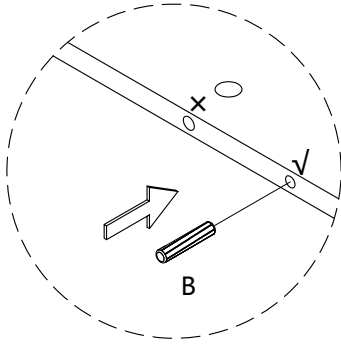

x 2

180°

Switch to the other side/
Auf die andere Seite wechseln

This side up way/Diese Seite nach oben

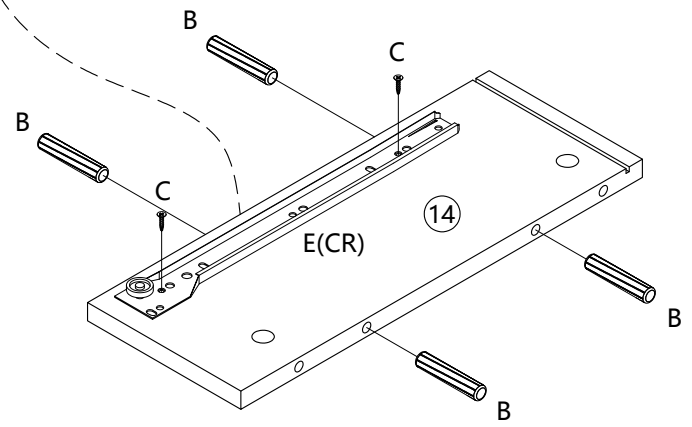
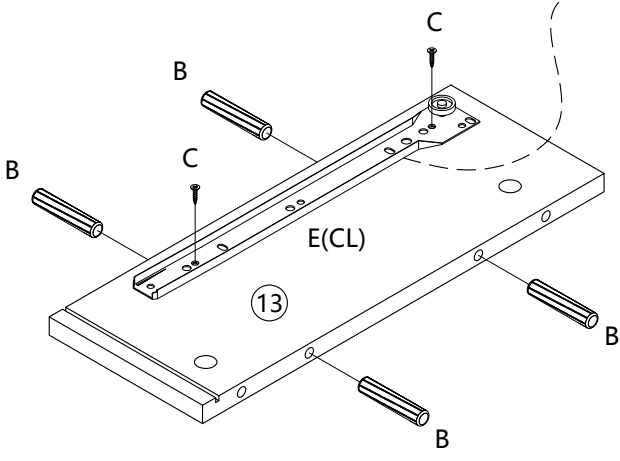
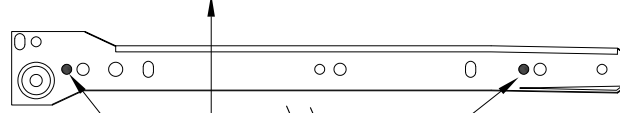

5



A2 x 8

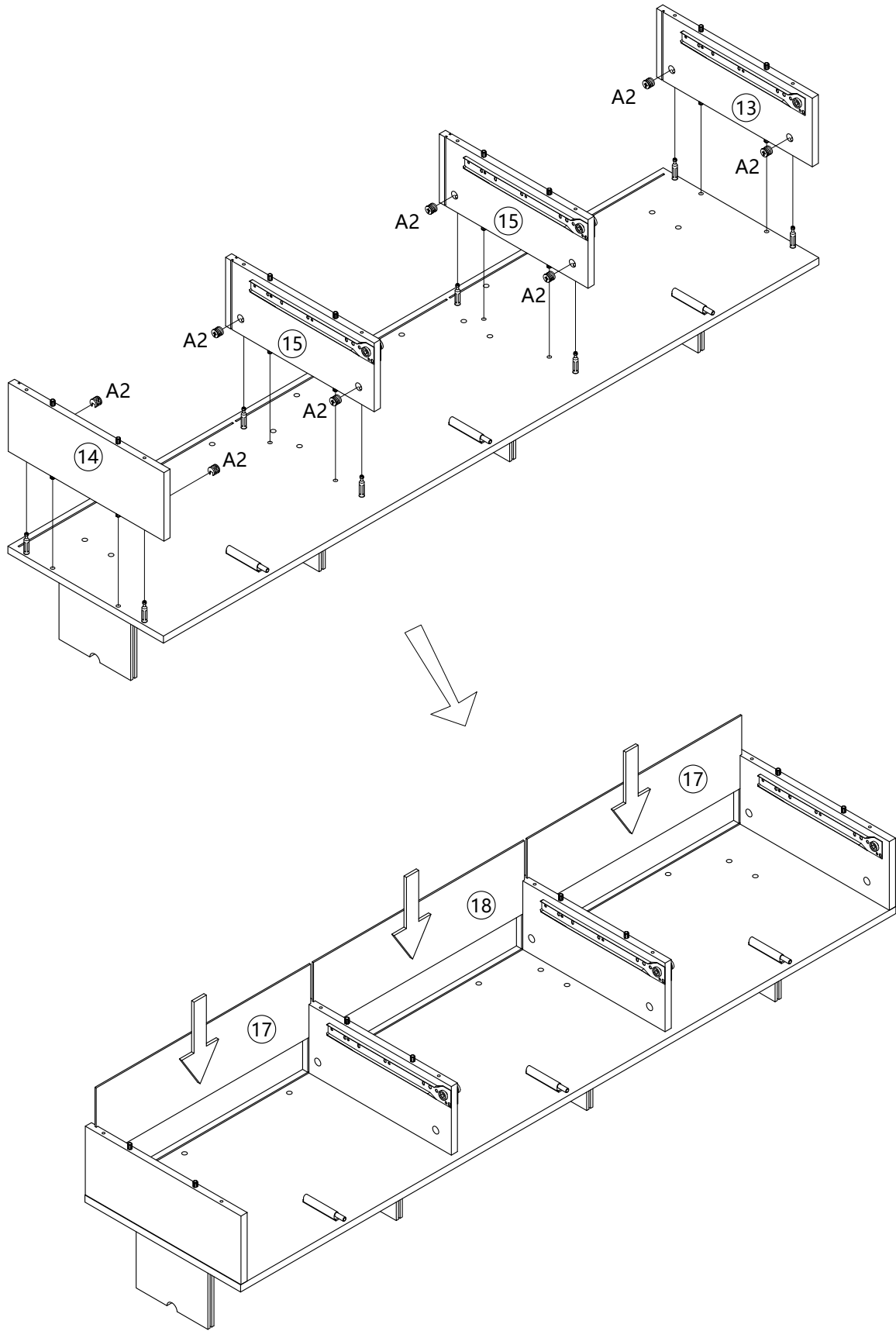

6



A1 x 10



7 x 50MM

F x 8

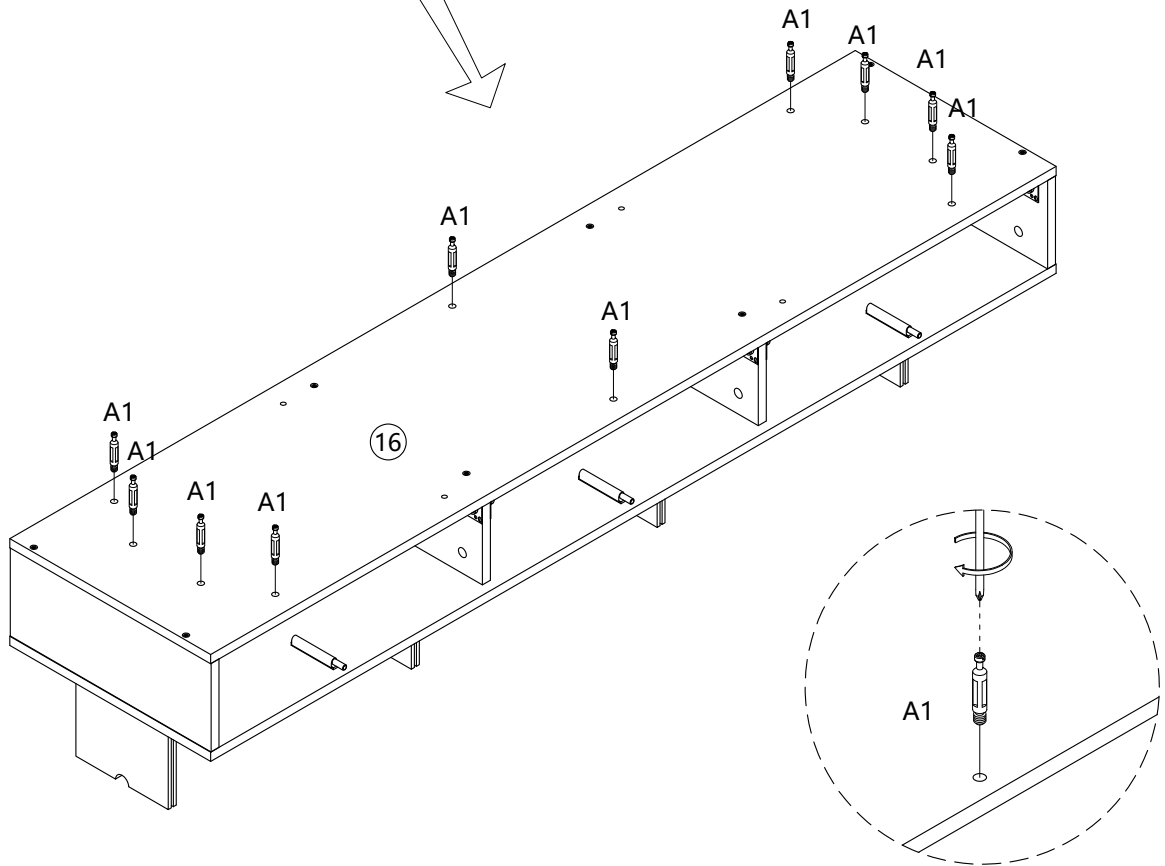
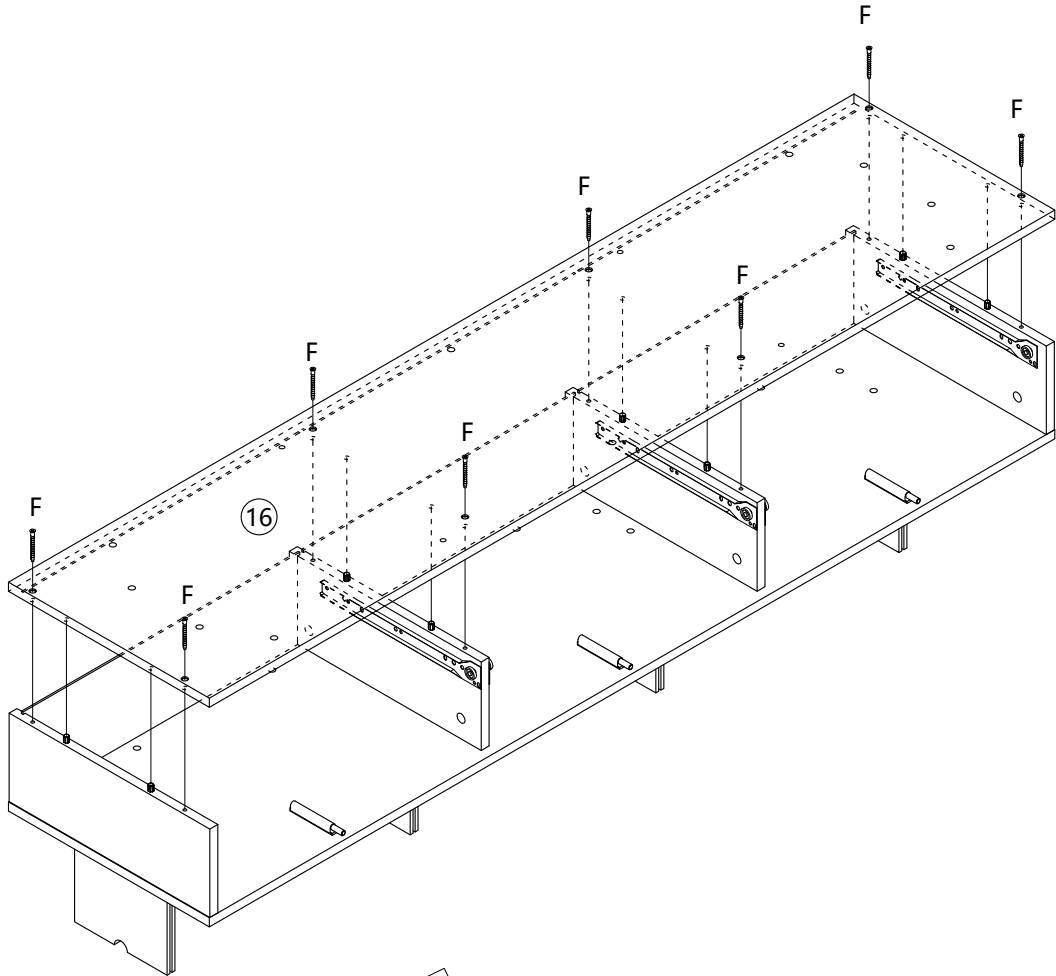

9



G x 8

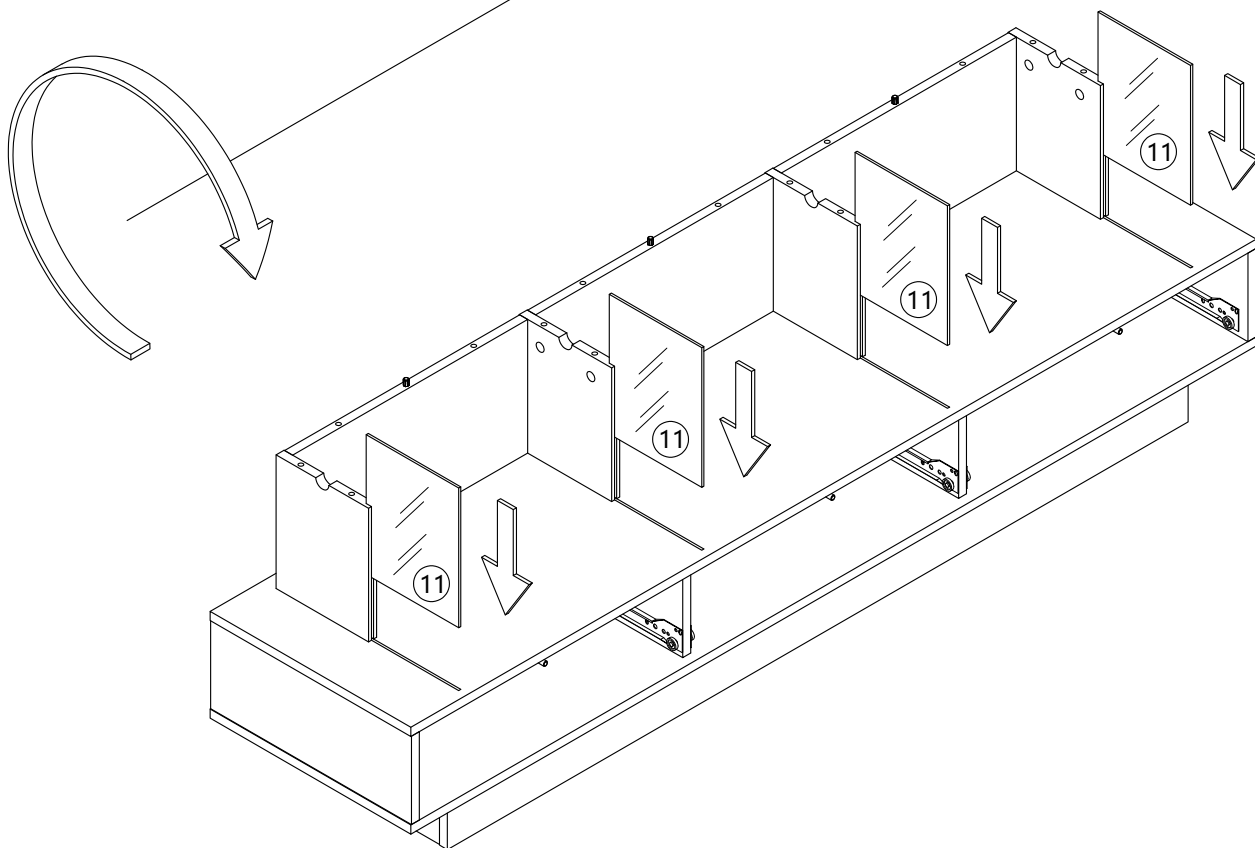
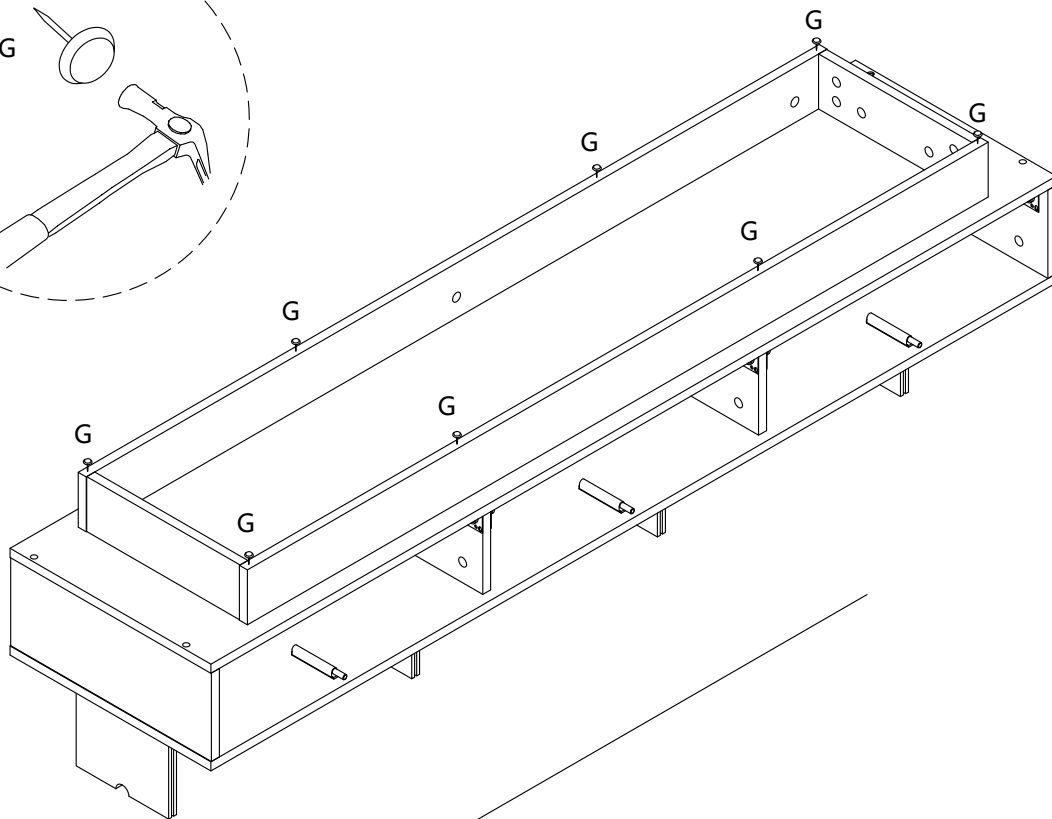
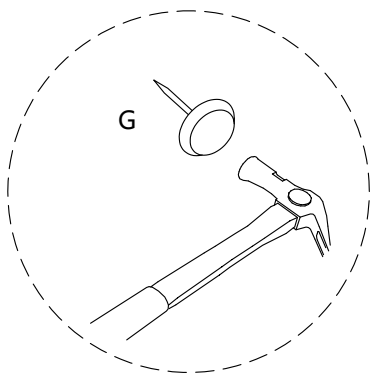

10

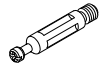

A1 x 25



8 x 40MM

B x 6

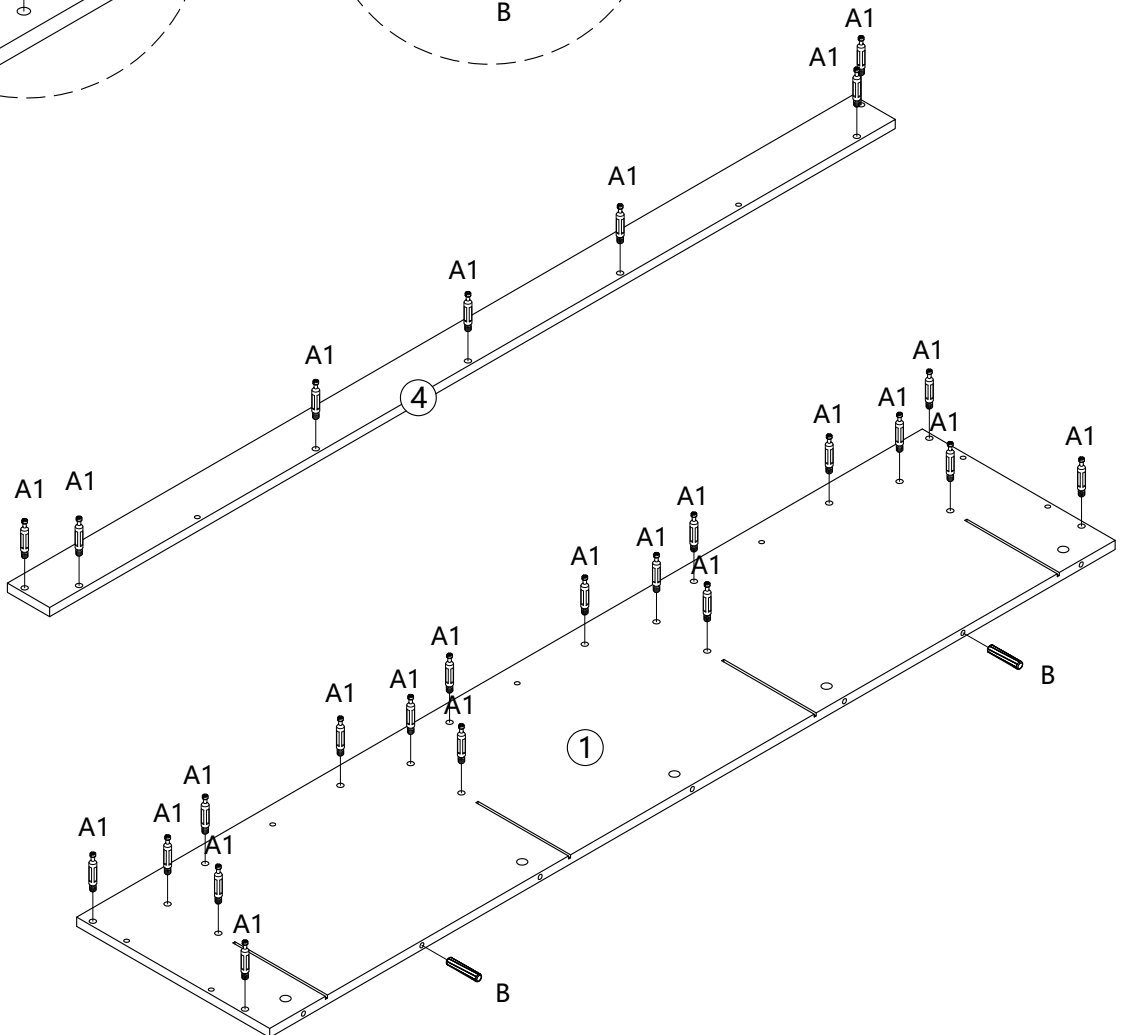
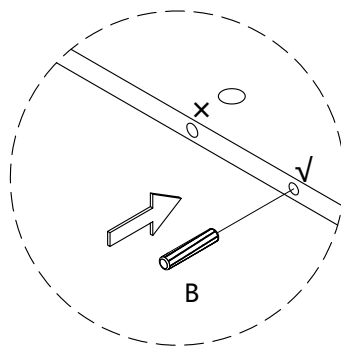
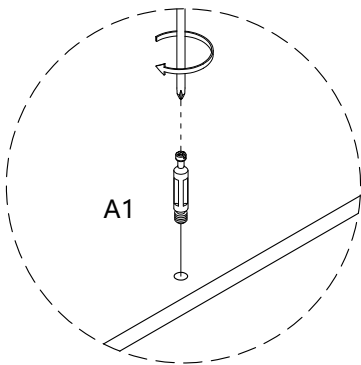
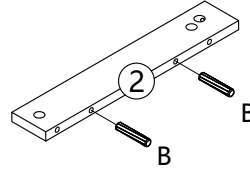
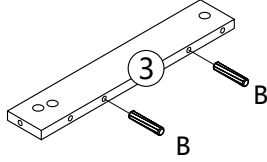

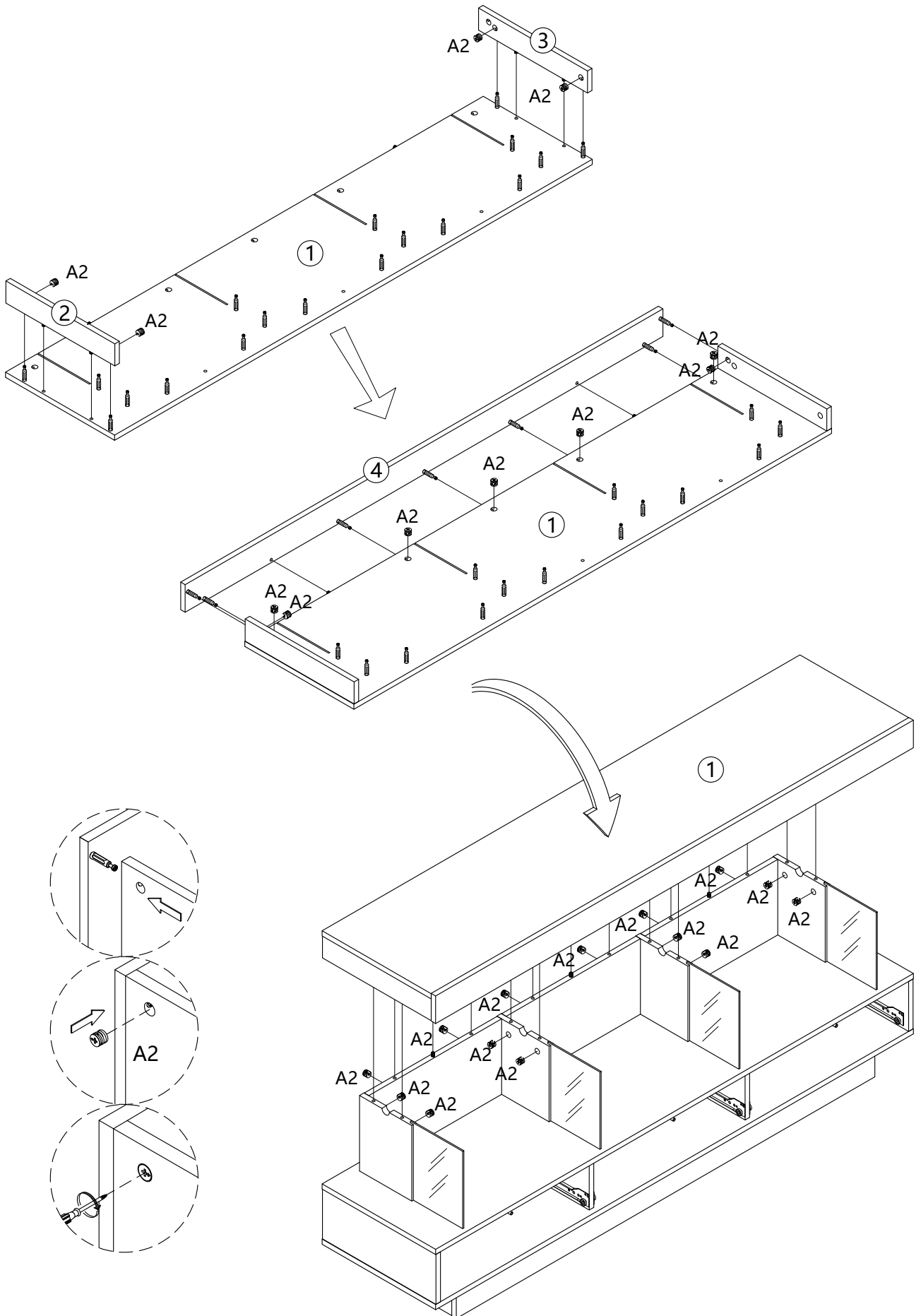

12

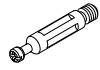

A1 x 8

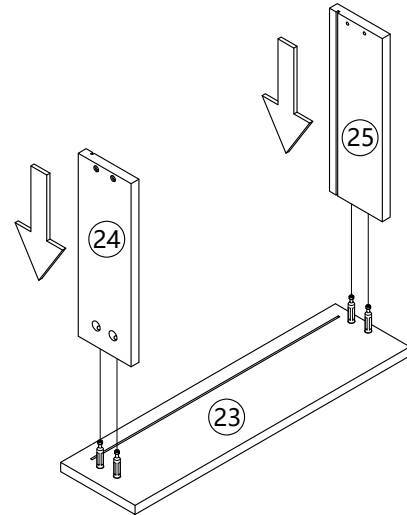
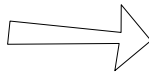
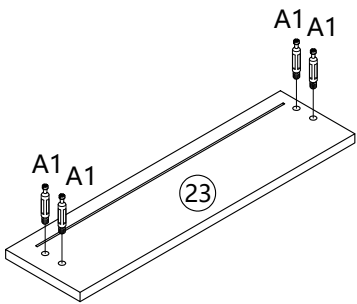
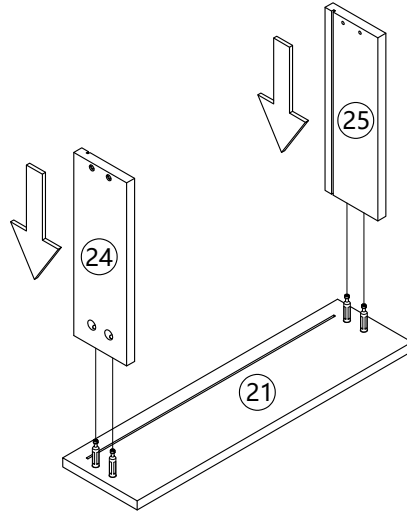
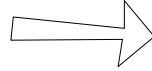
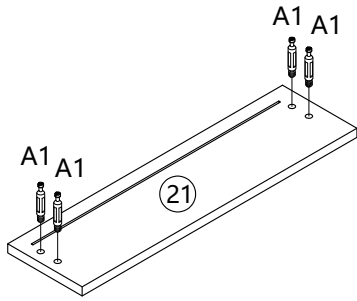

13



A2 x 8



3.5 x 35MM

D x 8

x 2

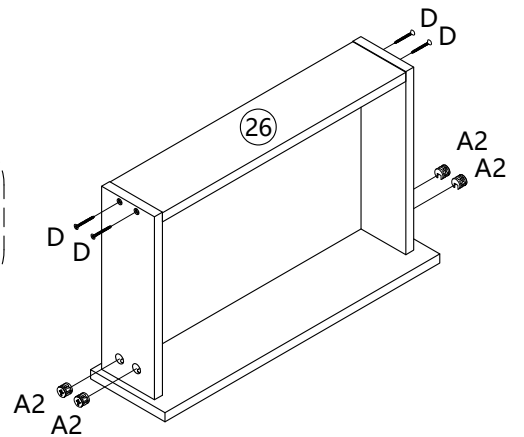
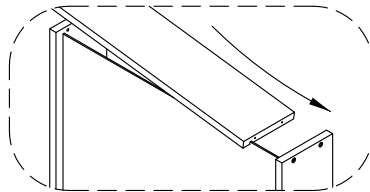
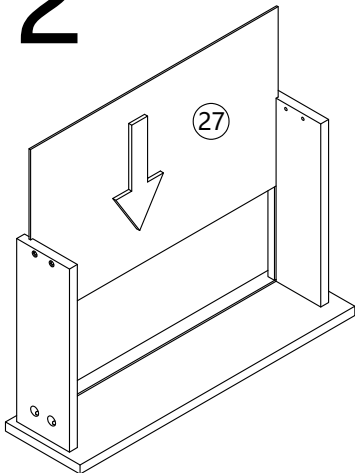

14

3.5 x 14MM
C x 8

C x 8

E(DL) x 2

E(DR) x 2

x 2

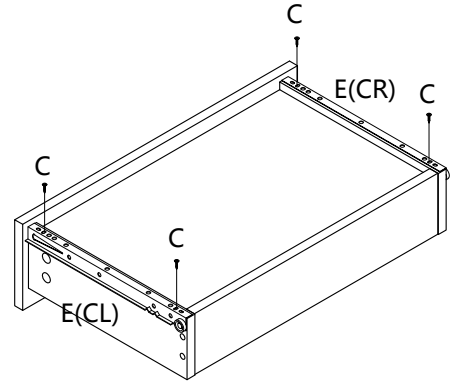
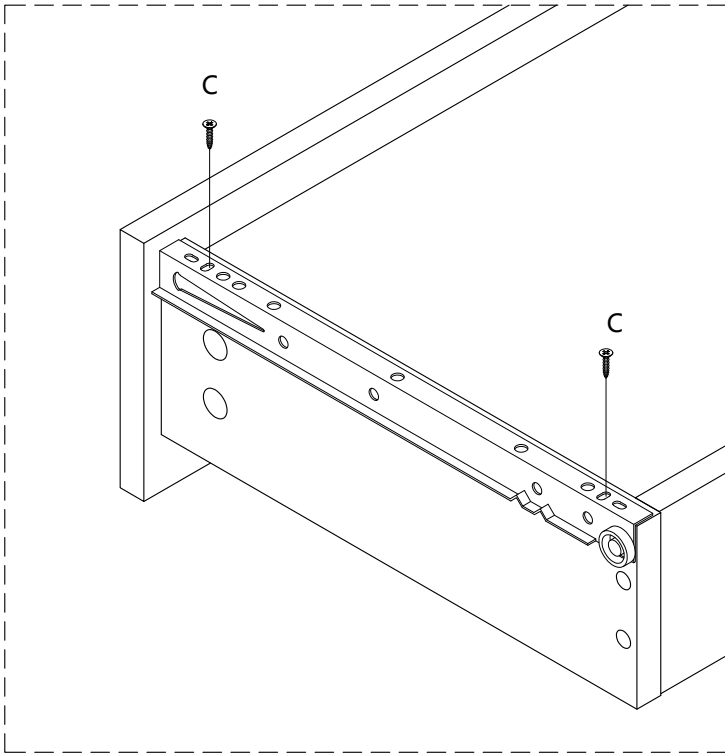

15

A1 x 4

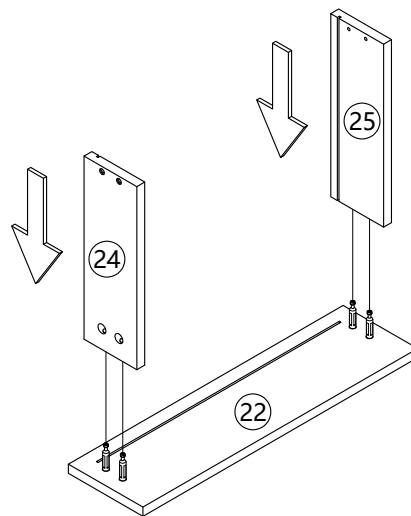
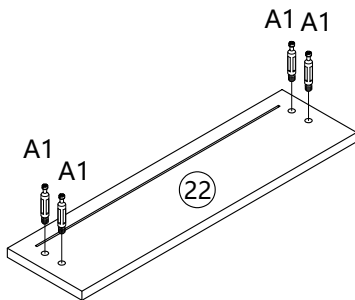

16



A2 x 4



3.5 x 35MM

D x 4

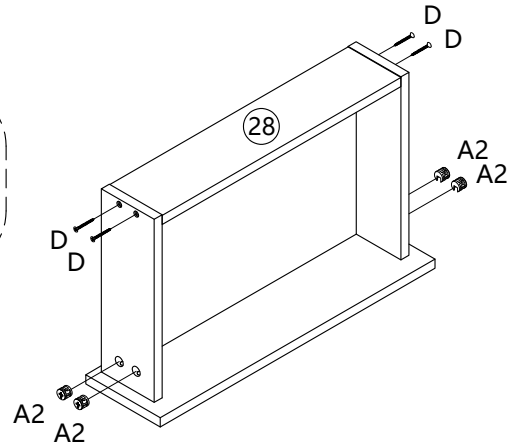
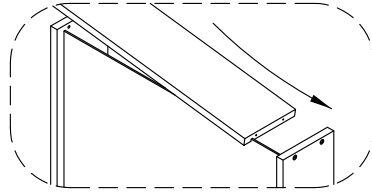
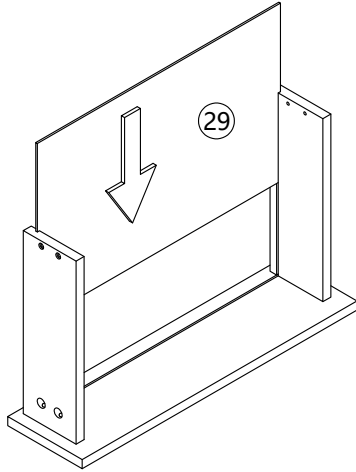

17



3.5 x 14MM

C x 4

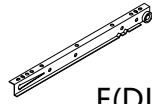

E(DL) x 1



E(DR) x 1

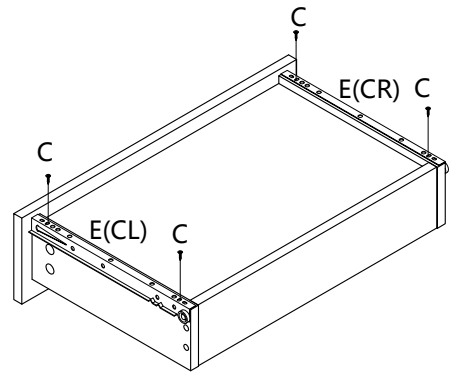
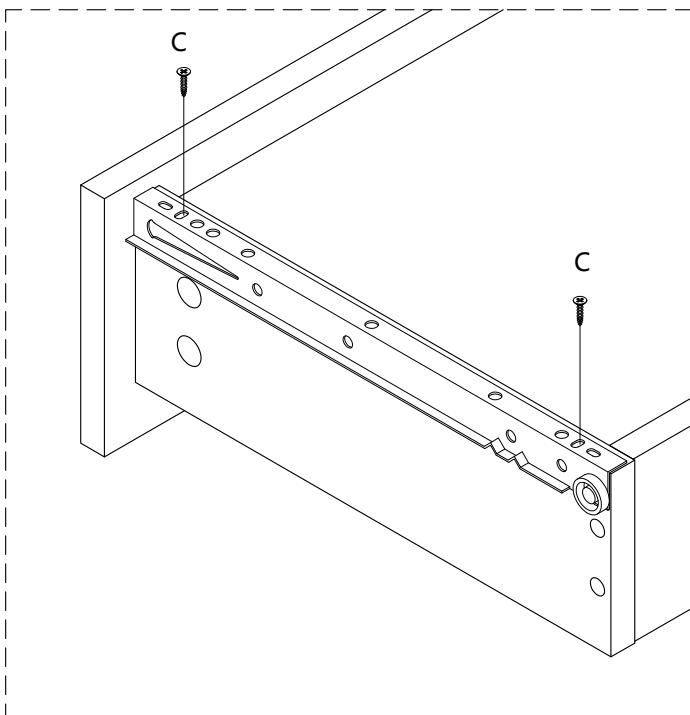

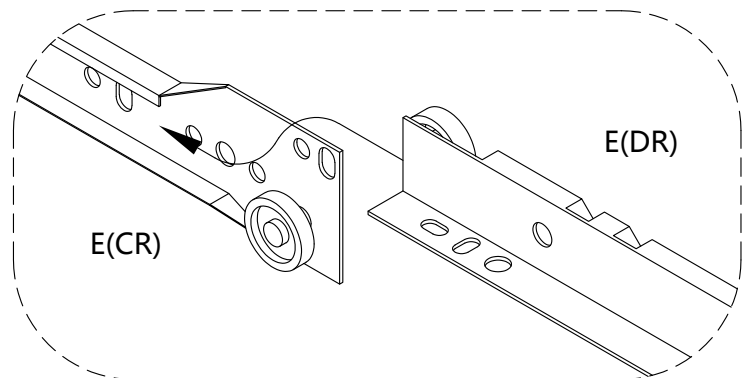
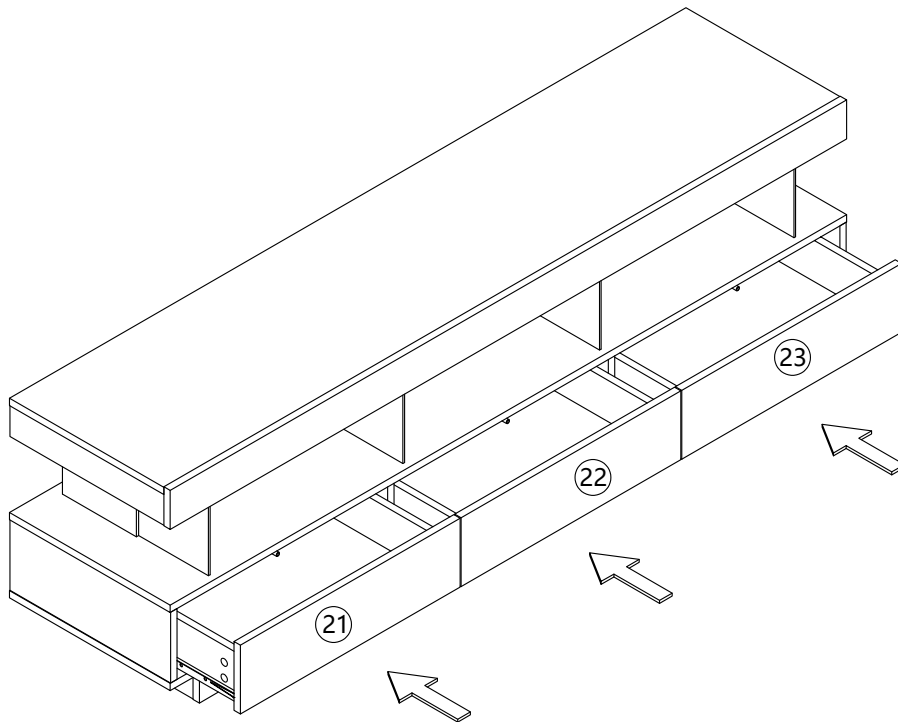

In order to make the product more beautiful, please paste hardware L on the exposed holes

Um das Produkt schöner zu machen, kleben Sie bitte Hardware L auf die freiliegenden Löcher

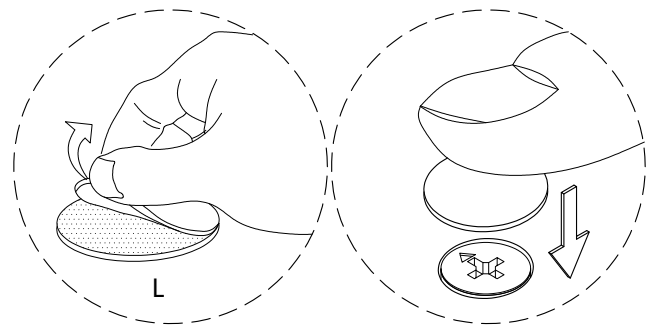

19

3.5 x 14MM C x 12

H x 12

K x 1



Scan to download App
control the Led light.

Scannen Sie, um die App
herunterzuladen, um das LED
-Licht zu steuern.

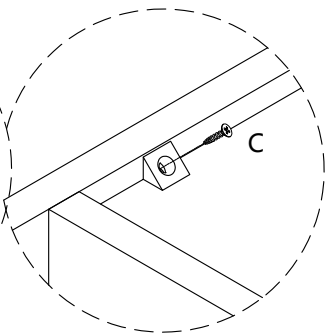
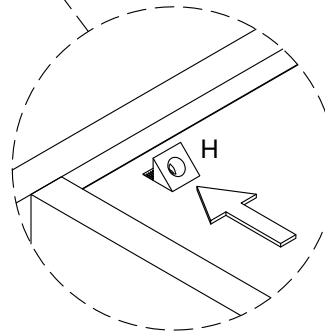
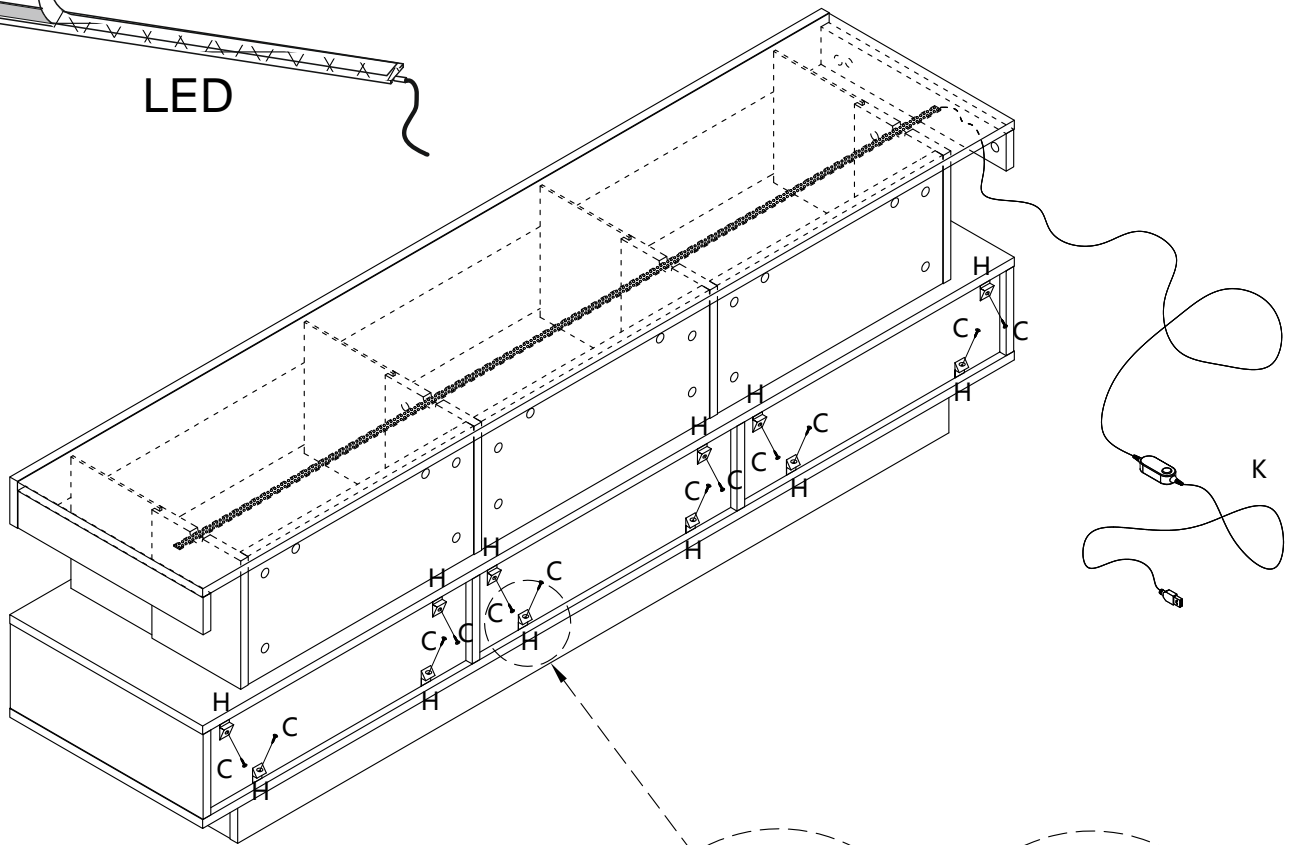
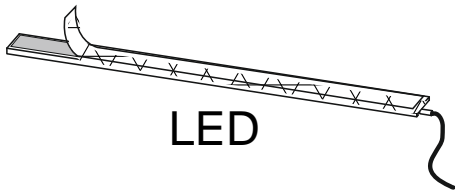
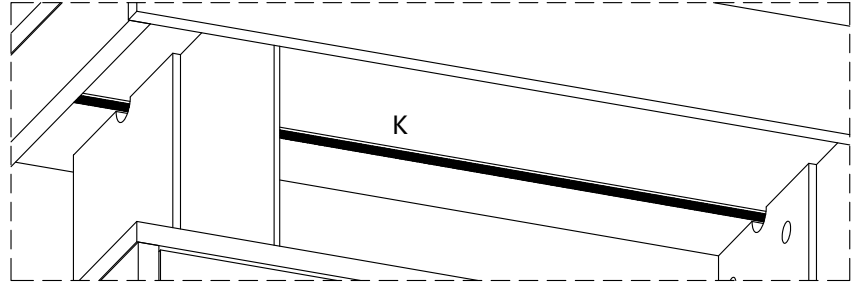

20

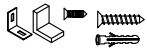

M x 2

1.



2.

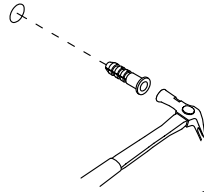

3.

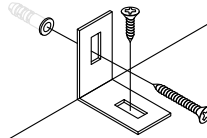

4.

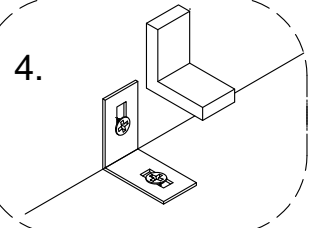

WALL

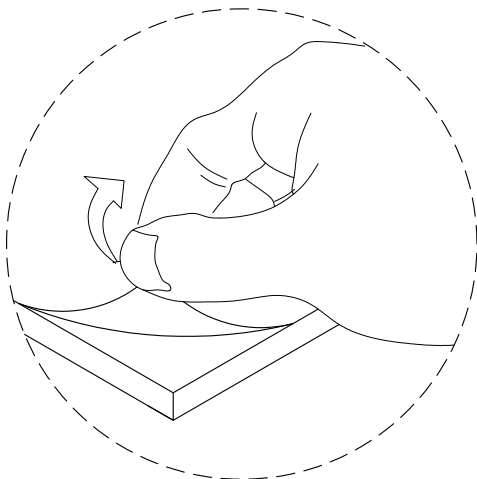
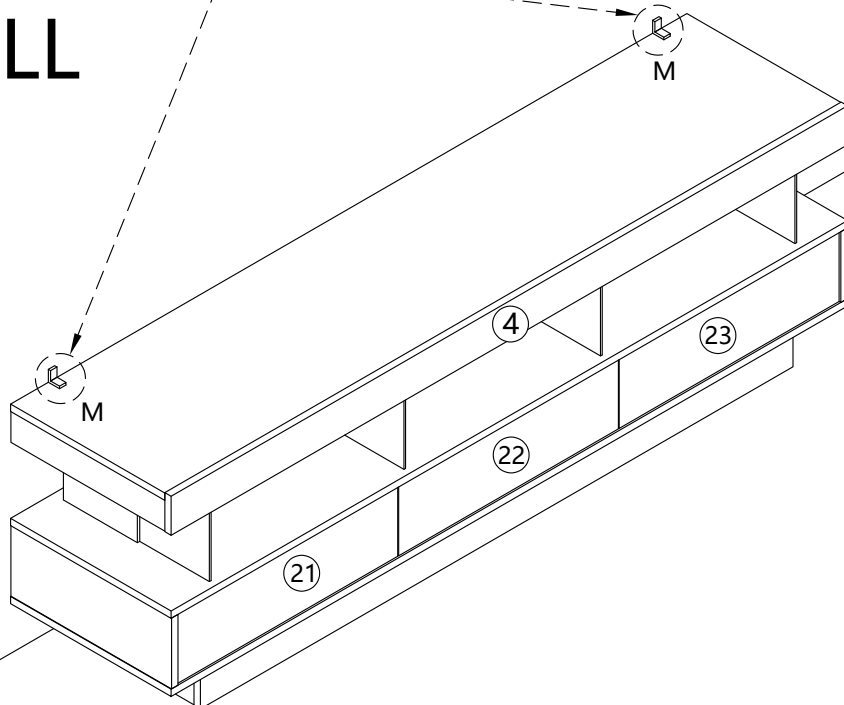

PLEASE NOTE: Part number 1. is covered with a tight plastic protective film. If there are scratches on the product after disassembly, please don't worry, it's not product damage. Please slowly tear off the protective plastic film on the surface along the edge. After peeling off, the product becomes smooth and clean.

Bitte beachten Sie: Teil Nr. 1. sind mit einer dichten Kunststoffschutzfolie abgedeckt. Wenn das Produkt nach der Demontage Kratzer aufweist, machen Sie sich bitte keine Sorgen, es handelt sich nicht um einen Produktschaden. Bitte ziehen Sie die schützende Kunststofffolie auf der Oberfläche entlang der Kante langsam ab. Nach dem Abziehen wird das Produkt glatt und sauber.

Verification of Compliance

Verification No.:	TMC210319126-E
Name and address of Applicant:	Shenzhen CWG Technology Co., Ltd 5 / F, No.264 Baoshi East Road, Shiyan street, Bao'an District, Shenzhen,China 518108
Name and address of Manufacturer	Shenzhen CWG Technology Co., Ltd 5 / F, No.264 Baoshi East Road, Shiyan street, Bao'an District, Shenzhen,China 518108
Product name:	LED Strip
Rated:	DC12V
Product model(s):	CWG-5050RGB-60D-12V , additional models reference attachment
Product trademark:	创唯光

This verification confirms that the product meets the requirements of the following standard. The conformity was demonstrated based on following standard(s) listed by European Commission as harmonized with EMC Directive 2014/30/EU.

EN IEC 55015:2019+A11:2020
IEC 61547:2020

The verification has been carried out in accordance with individual rules and conditions agreed with the applicant. Evaluation has been carried out in accordance with:

Test report(s) No.:	TMC210319126-E
Test conducted by:	TMC Testing Services (Shenzhen) Co., Ltd.
Verification issue date:	March 26, 2021

Notes:

This verification refers to the above mentioned product and its conformity in regards of above mentioned standard(s) was proven on test sample.

This verification does not imply meeting all essential requirements, assessment of the series-production or any other restricted Notified Bodies conformity assessment procedure appropriate for the product.

This verification holder shall use this verification in connection to verification of conformity and technical data relevant for the product the verification was issued.

TMC Testing Services (Shenzhen) Co., Ltd.

t:86-755-86642861 cert@tmc-lab.com www.tmc-lab.com

1st Floor, Block A1, Zone A, Xinshidai Gongrong Industrial Park, No. 2, Shihuan Road, Shiyan Street, Baoan District, Shenzhen, China



Lab Director
Lemon Rao



Attestation of Compliance

Declaration No.: TMC210319128-E

Name and address of Applicant: **Shenzhen CWG Technology Co., Ltd**
5 / F, No.264 Baoshi East Road, Shiyan street, Bao'an District, Shenzhen,China
518108

Name and address of Manufacturer: **Shenzhen CWG Technology Co., Ltd**
5 / F, No.264 Baoshi East Road, Shiyan street, Bao'an District, Shenzhen,China
518108

Product name: **LED Strip**

Rated: DC12V
CWG-5050RGB-60D-12V, CWG-5050RGB-30D-12V , CWG-5050RGB-18D-12V,
CWG-5050RGB-60D-24V, CWG-5050RGB-60D-5V, CWG-5050RGB-30D-5V,
CWG-5050RGB-18D-5V, CWG-5050-60D-12V, CWG-5050-30D-12V,
CWG-5050-60D-24V, CWG-HC5050RGB-60D-12V,
CWG-HC5050RGB-30D-12V, CWG-HC5050RGB-60D-24V,
Product model(s): CWG-HC5050-60D-12V, CWG-HC5050-30D-12V, CWG-HC5050-60D-24V,
CWG-HC5050RGB-30D-5V, CWG-HC5050RGB-60D-5V,
CWG-HC5050RGB-144D-5V, CWG-2835-60D-12V, CWG-2835-120D-12V,
CWG-2835-60D-24V, CWG-2835-120D-24V, CWG-2835-60D-5V,
CWG-2835-120D-5V

Product trademark: 创唯光

This Attestation of Compliance confirms that the product meets the requirements of the following standard.

BS EN IEC 55015:2019+A11:2020

IEC 61547:2020

The Attestation of Compliance has been carried out in accordance with individual rules and conditions agreed with the applicant. Evaluation has been carried out in accordance with:

Test report(s) No.: TMC210319128-E

Test conducted by: TMC Testing Services (Shenzhen) Co., Ltd.

Declaration issue date: March 26, 2021

Notes:

This Attestation of Compliance is issued according to the Great Britain legislation Electromagnetic Compatibility Regulations 2016 It confirms that the listed products complies with all essential requirements of the Regulations and applies only to the sample and its technical documentation to TMC Testing Services (Shenzhen) Co., Ltd. for testing.

After preparation of the necessary technical documentation (which must be kept for up to 10 years after the product is placed on the GB market) as well as the UK Declaration of Conformity, the required UKCA marking can be affixed on the product. Other relevant Regulations have to be observed.

TMC Testing Services (Shenzhen) Co., Ltd.

t:86-755-86642861 cert@tmc-lab.com www.tmc-lab.com

1st Floor, Block A1, Zone A, Xinshidai Gongrong Industrial Park, No. 2, Shihuan Road, Shiyan Street, Baoan District, Shenzhen, China



**UK
CA**