

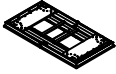





ASSEMBLY INSTRUCTIONS

BAB-DC-6-31-T/B

NO.	Parts List	Q'TY
A	 Table	1
B	 Leg	2

NO.	Parts List	Q'TY
1	 5/ 16" x 1" 3/8' Allen Bolts	20
2	 14 mm x 1.5 mm Lock Washers	20
3	 22 mm x 1.5 mm Flat Lock Washers	20
4	 1/ 6" x 4" 1/4 Allen Key	1

STEP 1

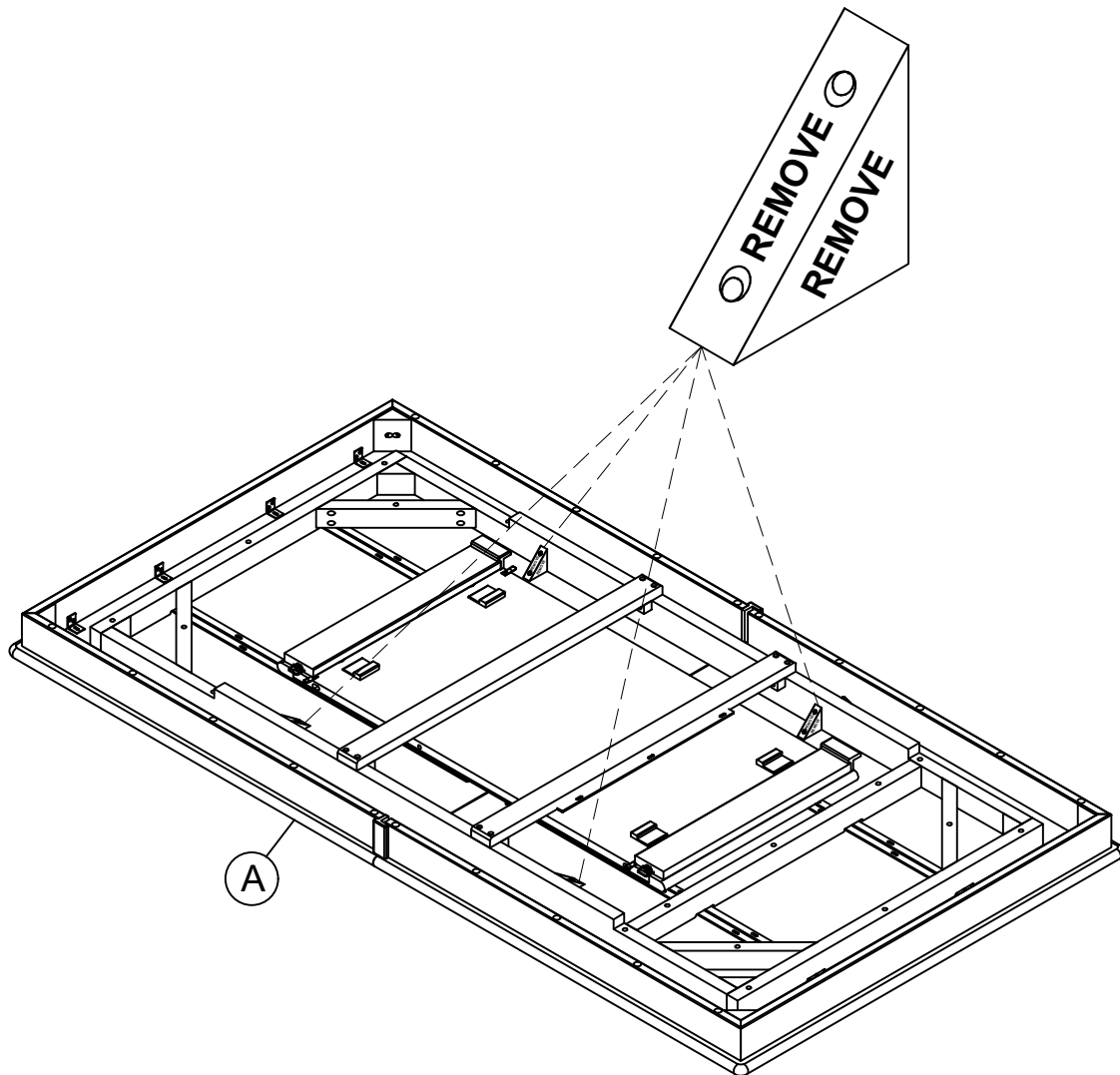

STEP 2

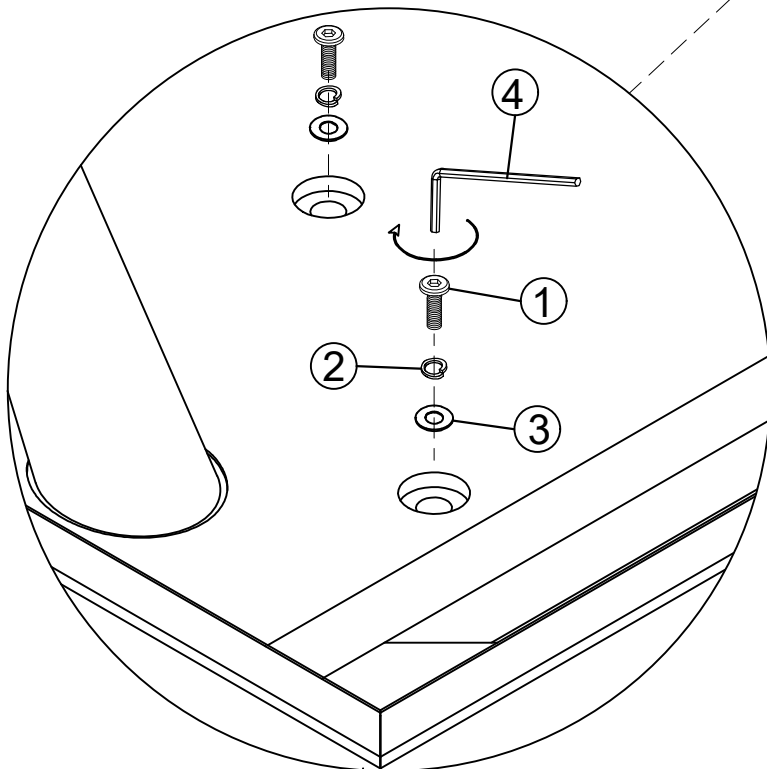
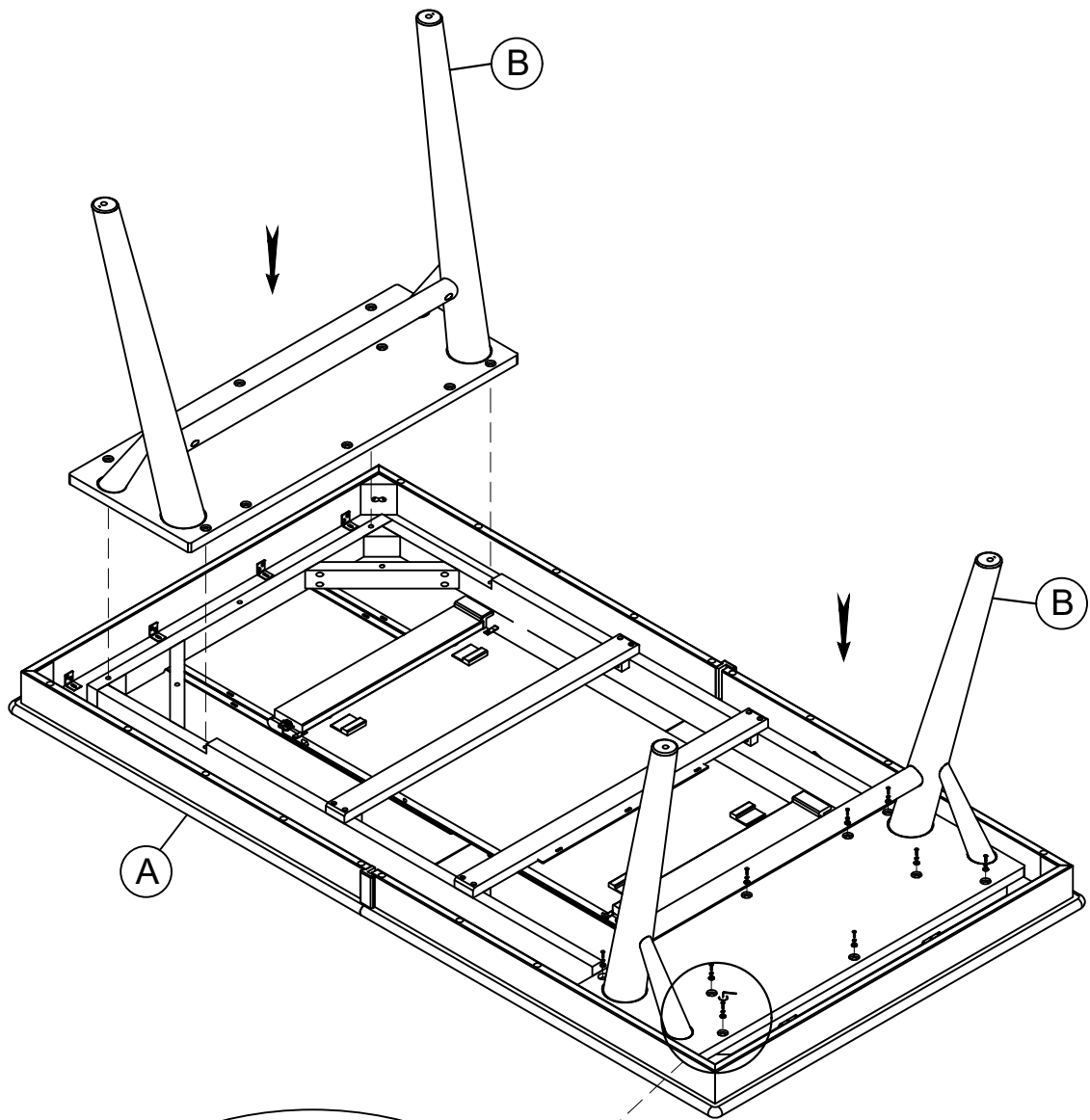

STEP 3

Important Note

Need 2 adult to flip over the assembled table. Do not lean any weight on table leg during the flipping process

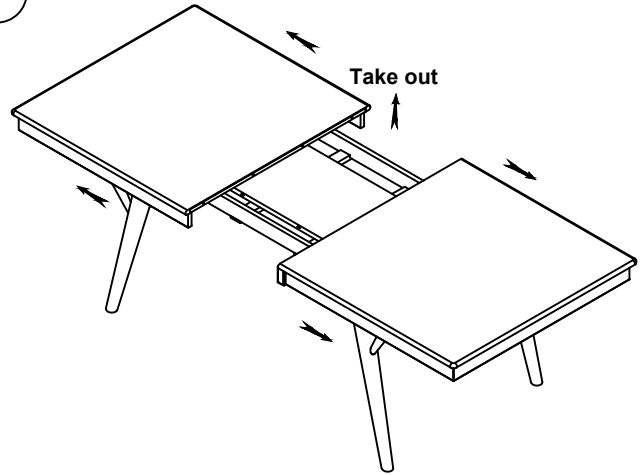
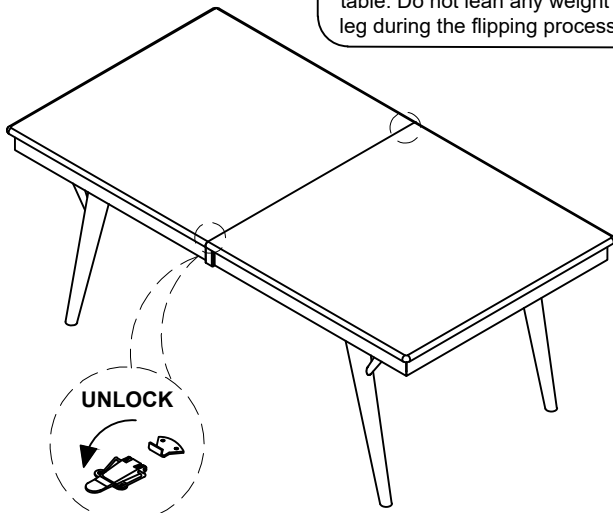

STEP 4

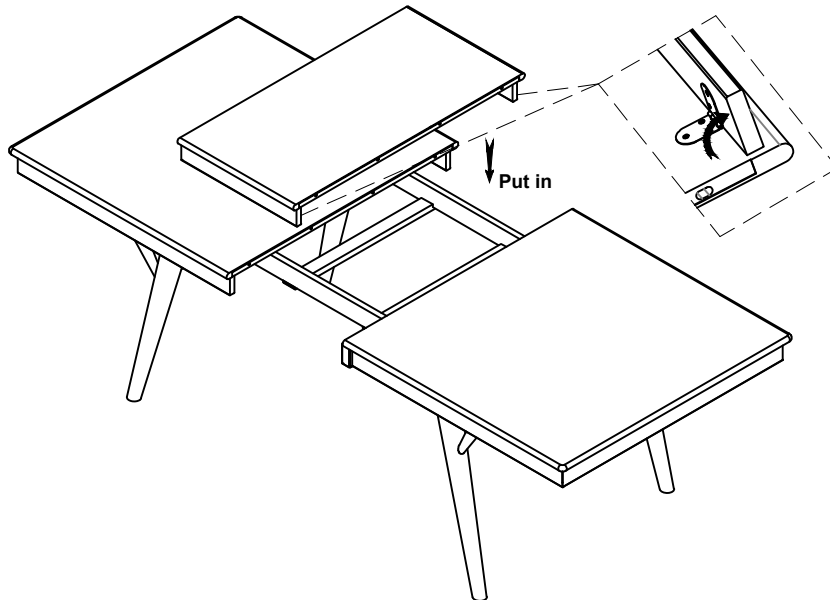

STEP 5

