

# **ASSEMBLY INSTRUCTION**

### ASSEMBLY TIPS :

1. Remove hardware from box and sort by size.
2. Please check to see that all hardware and parts are present prior to start of assembly.
3. Please follow attached instructions in the same sequence as numbered to assure fast & easy assembly.



#### Warning !

1. Don't attempt to repair or modify parts that are broken or defective. Please contact the store immediately.
2. This product is for home use only and not intended for commercial establishment.

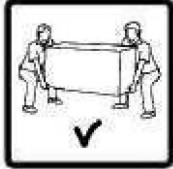

ASSEMBLY TIME	8 MINUTES
---------------	-----------

### PARTS IDENTIFICATION

### HARDWARE IDENTIFICATION

**A** TABLE TOP

1 PC

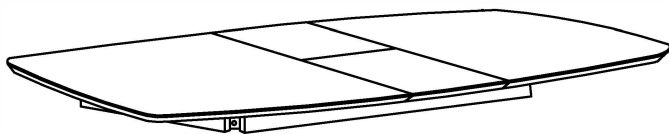

**1** BOLT + LOCK WASHER  
+ FLAT WASHER

8 SETS

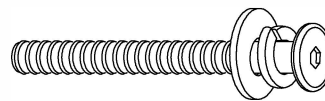

**B** TABLE LEG

4 PCS

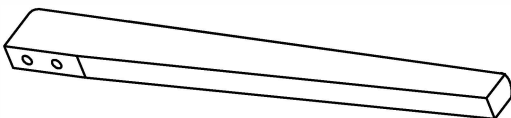

**2** ALLEN WRENCH

1 PC

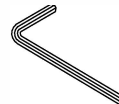

NOTE : PHILLIPS HEAD SCREW DRIVER IS  
REQUIRED IN THE ASSEMBLY PROCESS;  
HOWEVER MANUFACTURER DOES NOT  
PROVIDE THIS ITEM.

# STEP 1

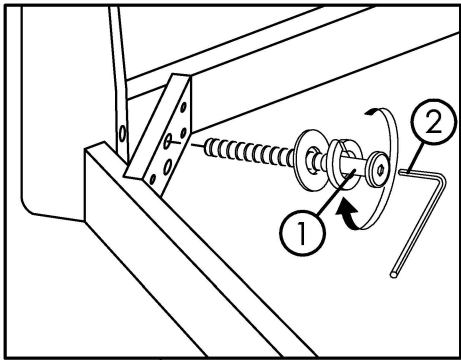

Note : This is for shipping purpose only, please remove before beginning the assembly.

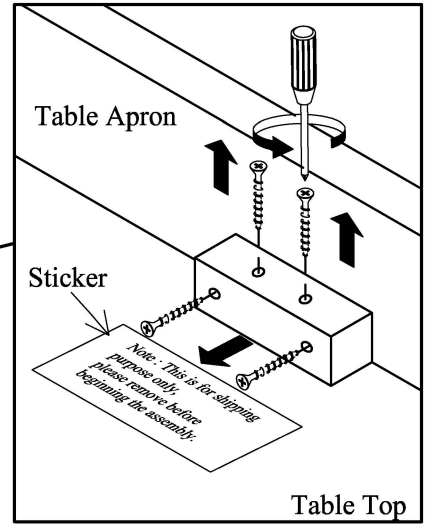
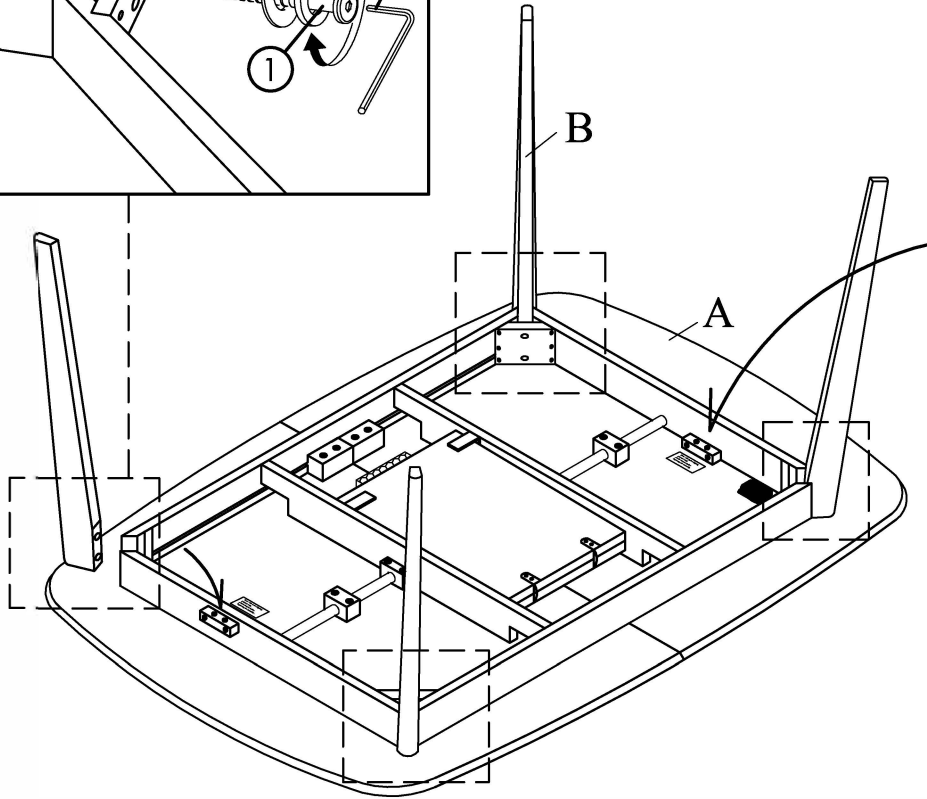

# STEP 2

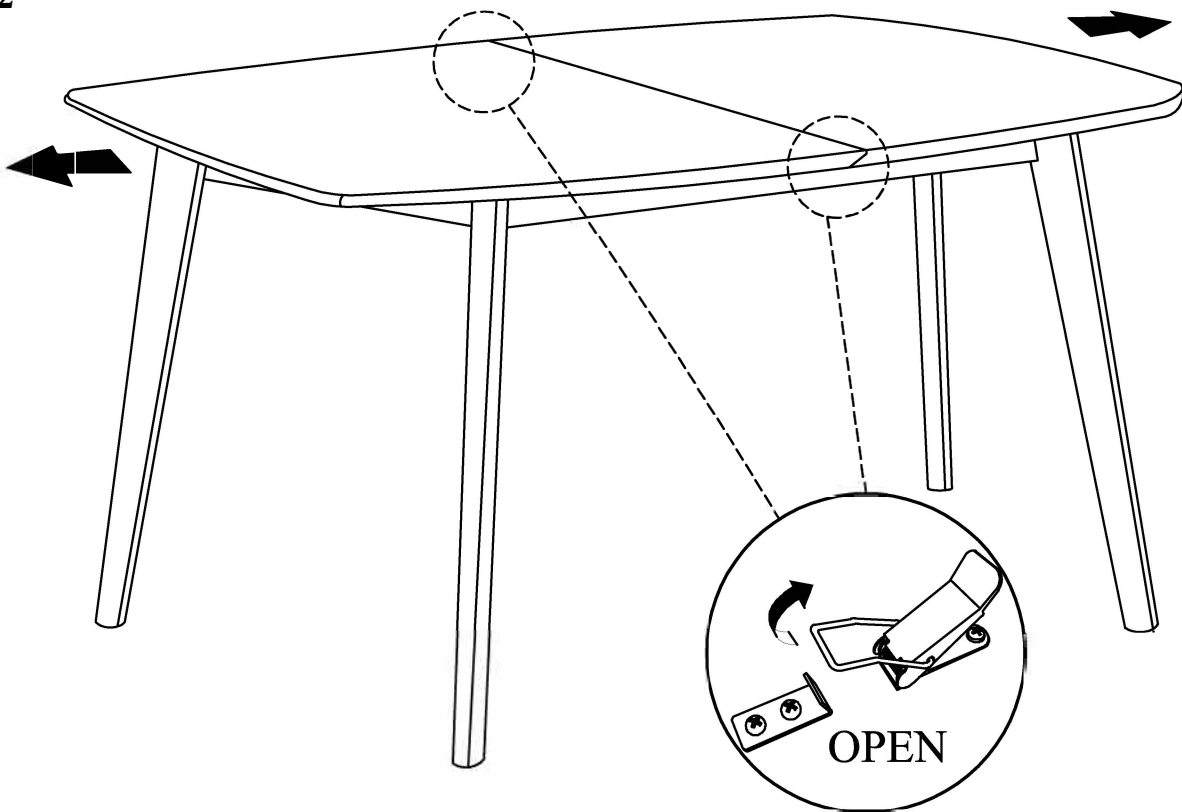

**STEP 3**

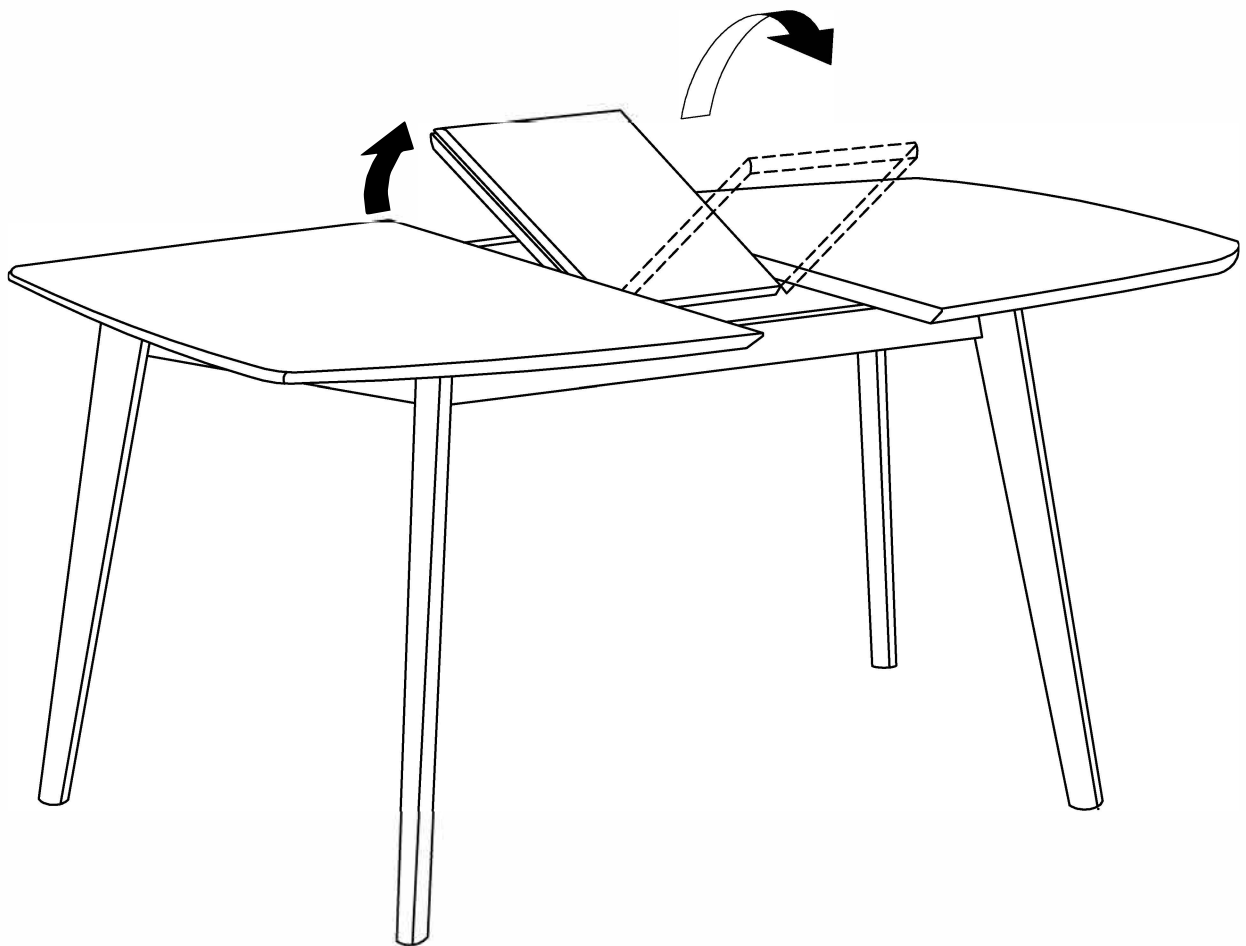

**STEP 4**

