

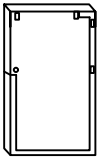

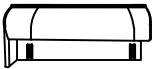

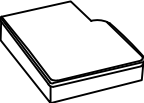







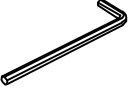
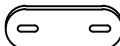

Accessories list(sitting sofa)

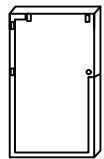
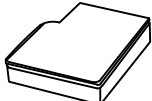
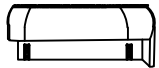
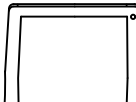

Carton 1/3

<p>A</p>  <p>Left seat frame(1)</p>	<p>B</p>  <p>Left armrest(1)</p>	<p>C</p>  <p>Left seat cushion (1)</p>	<p>D</p>  <p>Left backrest(1)</p>	<p>①</p>  <p>Latch(4)</p>
<p>②</p>  <p>Sofa feet (12)</p>	<p>③</p>  <p>8*65 Screw(12)</p>	<p>④</p>  <p>M5*105*55mm Wrench (1)</p>	<p>⑤</p>  <p>50 Metal plate (2)</p>	<p>⑥</p>  <p>6*25 Screw (4)</p>
<p>⑦</p>  <p>6*16 Gasket (4)</p>	<p>⑧</p>  <p>M4*65*23 Wrench(1)</p>	<p>⑨</p>  <p>U connector (2)</p>	<p>⑩</p>  <p>29*13 Hardware (6)</p>	<p>⑪</p>  <p>M4*100*35 Wrench (1)</p>
<p>⑫</p>  <p>6*40 Screw (24)</p>	<p>⑬</p>  <p>6*16 Gasket (24)</p>			

Carton 2/3

<p>E</p>  <p>Right seat frame(1)</p>	<p>F</p>  <p>Right seat cushion(1)</p>	<p>G</p>  <p>Right armrest(1)</p>	<p>H</p>  <p>Right backrest(1)</p>	<p>I</p>  <p>Left armrest soft bag(1)</p>
<p>J</p>  <p>Right armrest soft bag(1)</p>				

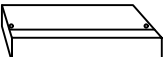
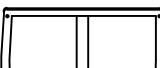
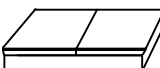
Carton 3/3

<p>K</p>  <p>Double seat frame (1)</p>	<p>L</p>  <p>Double backrest (1)</p>	<p>M</p>  <p>Double seat cushion(1)</p>	<p>N</p>  <p>Backrest cushion (4)</p>	<p>O</p>  <p>Pillow(4)</p>
---	---	--	--	---

- 1、 Part B、 C、 D、 1、 ②、 ③、 ④、 ⑤、 ⑥、 ⑦、 ⑧、 ⑨、 ⑩、 ⑪、 ⑫、 ⑬ in the box 1/3
- 2、 Part F、 G、 H、 I、 J in the box 2/3
- 3、 Part L、 M、 N、 O in the box 3/3

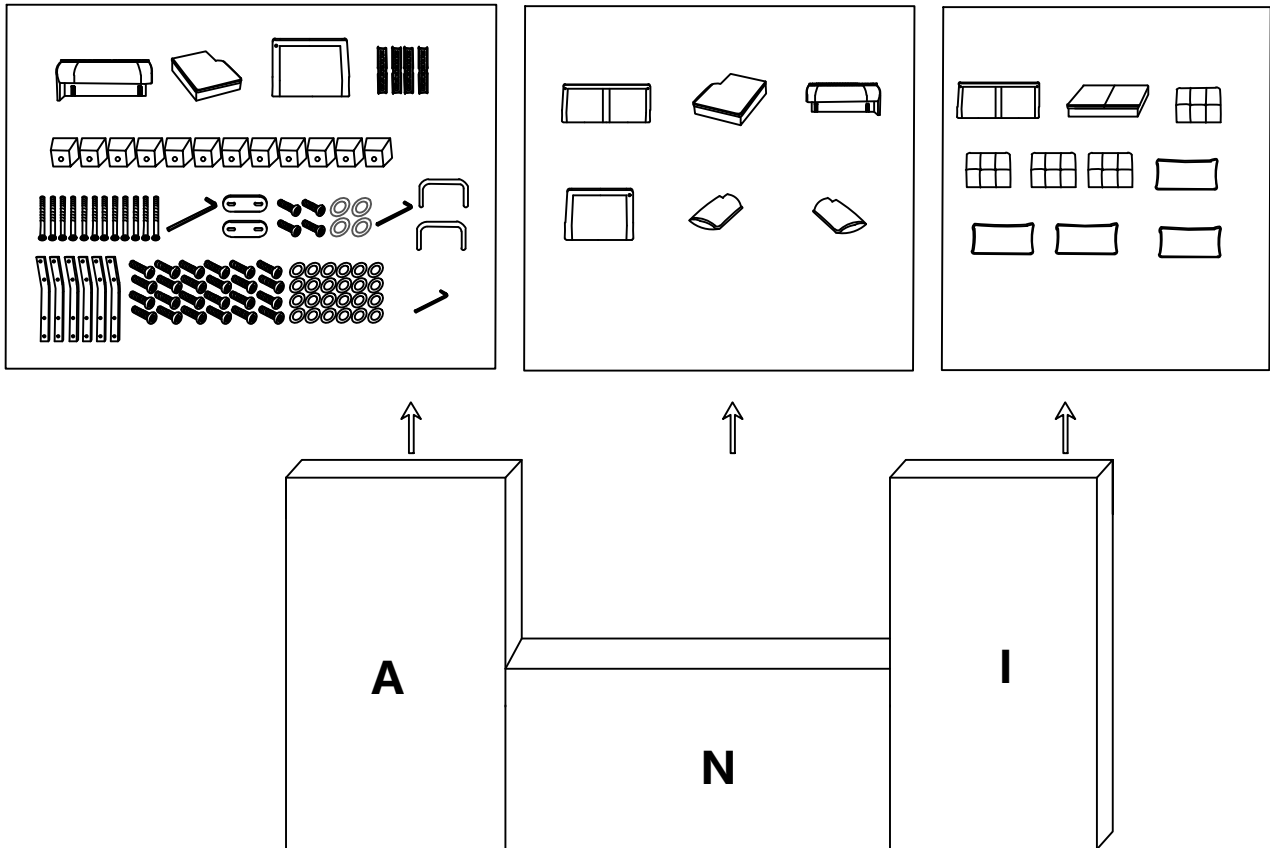

STEP1: Install the sofa feet (part 2) to the left seat frame (part A)

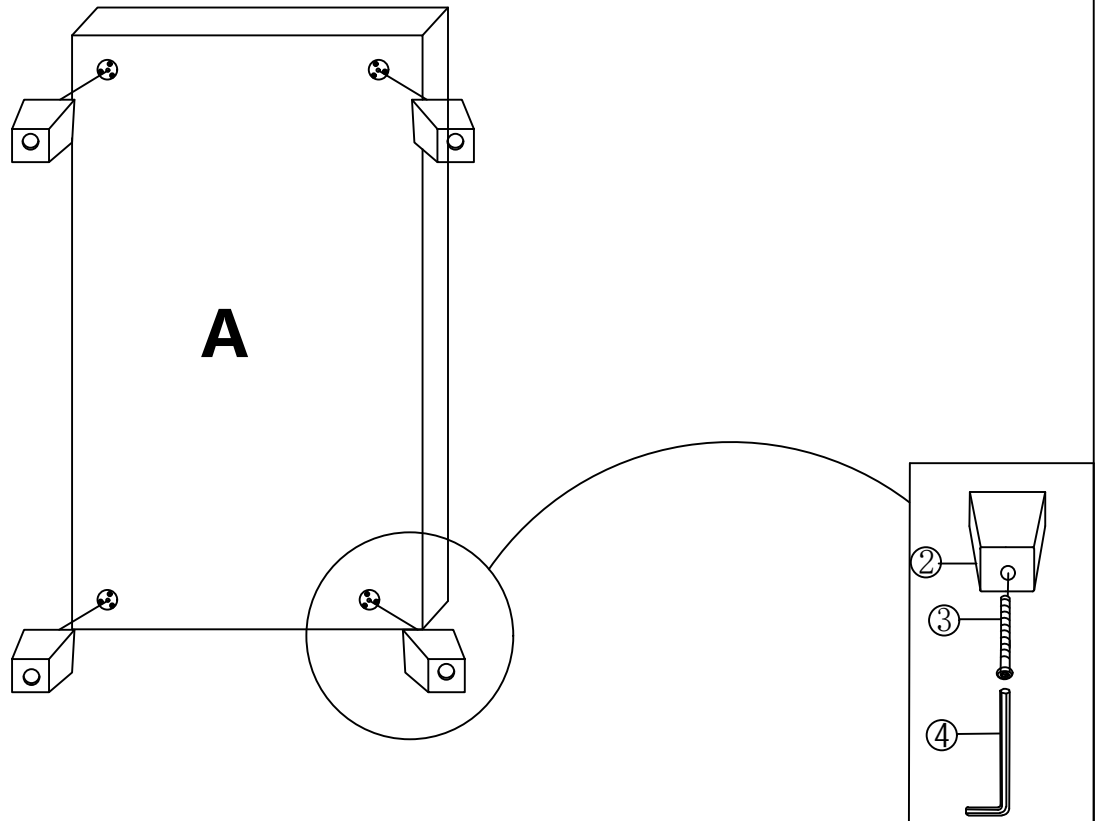

STEP2: Install the sofa feet (part 2) to the right seat frame (part E)

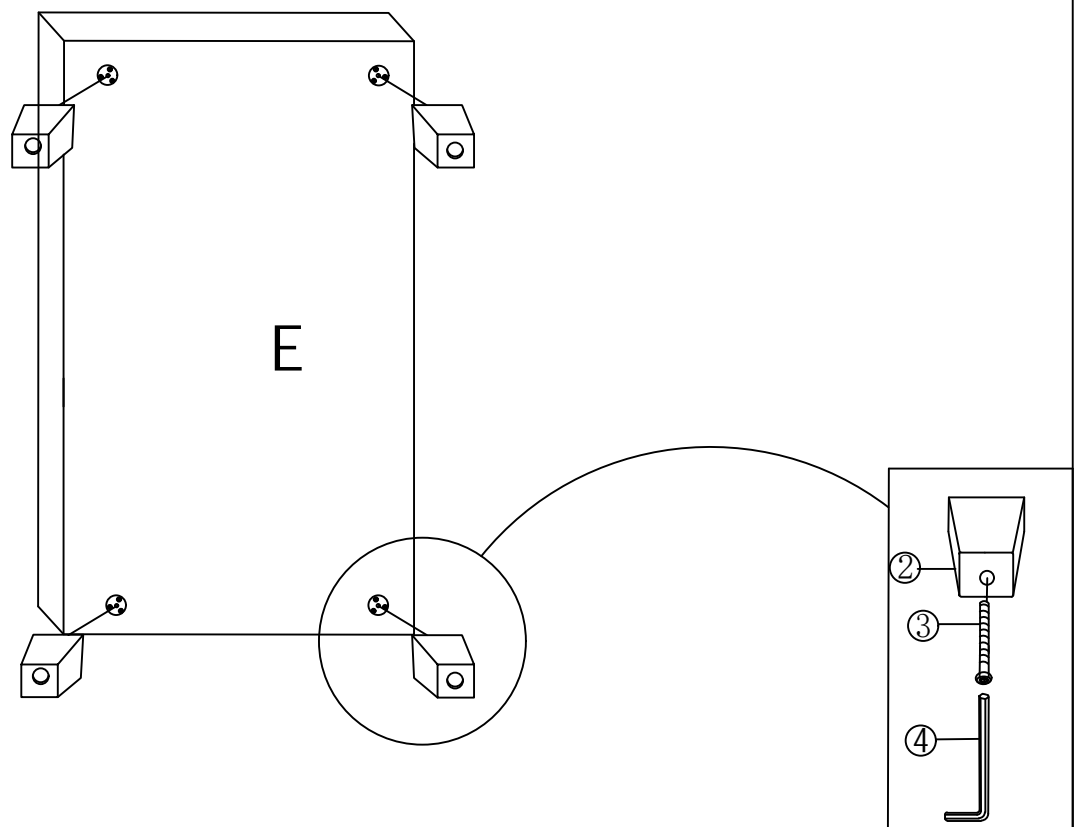

STEP3: Install the sofa feet (part 2) to the double seat frame (part K)

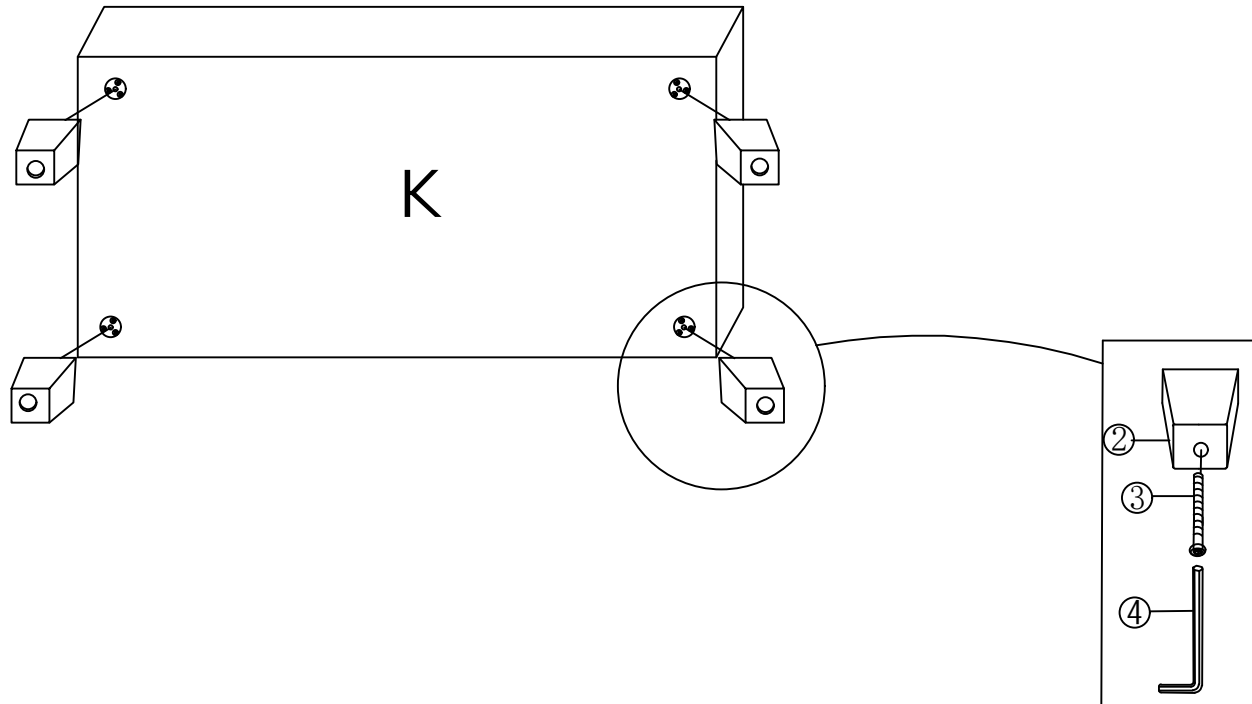

STEP4: Use the U-connector (part 9) to connect the seat frames together

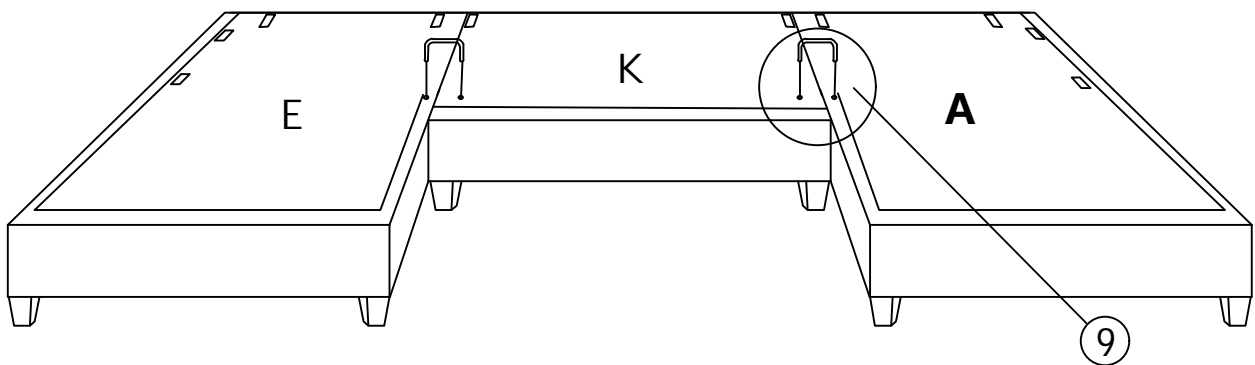

STEP5: Connect the right armrest(part G)to the right seat frame(part E)

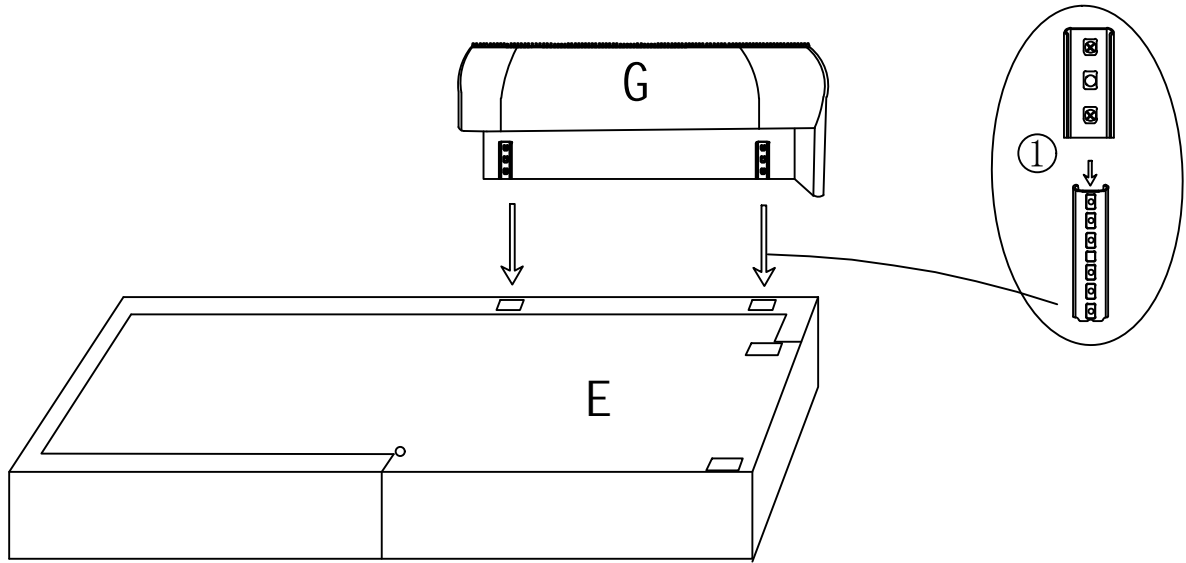

STEP6: Connect the left armrest(part B)to the left seat frame(part A)

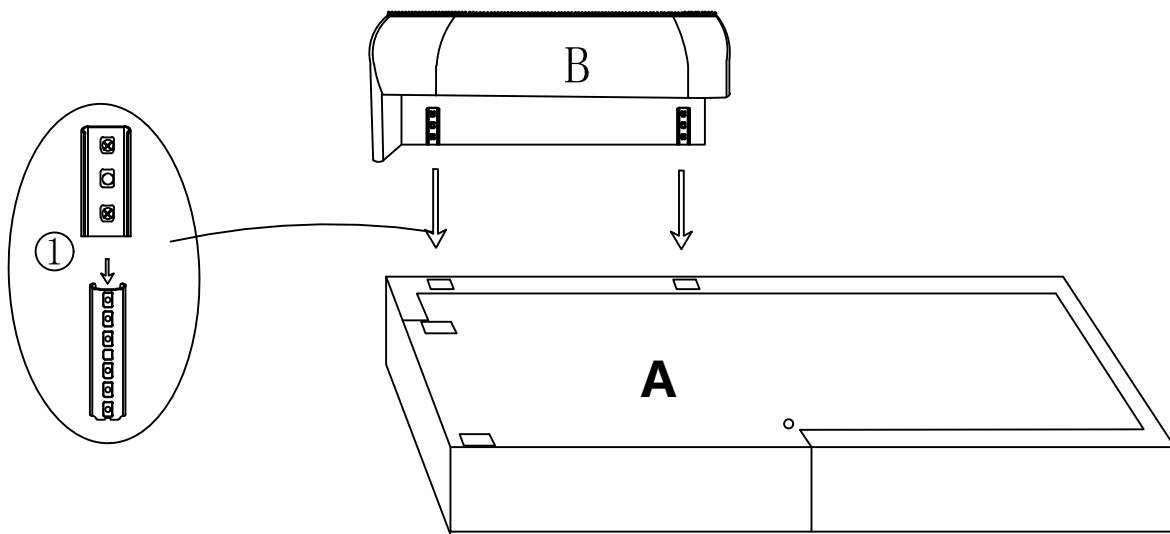

STEP7: Armrests assembly is completed

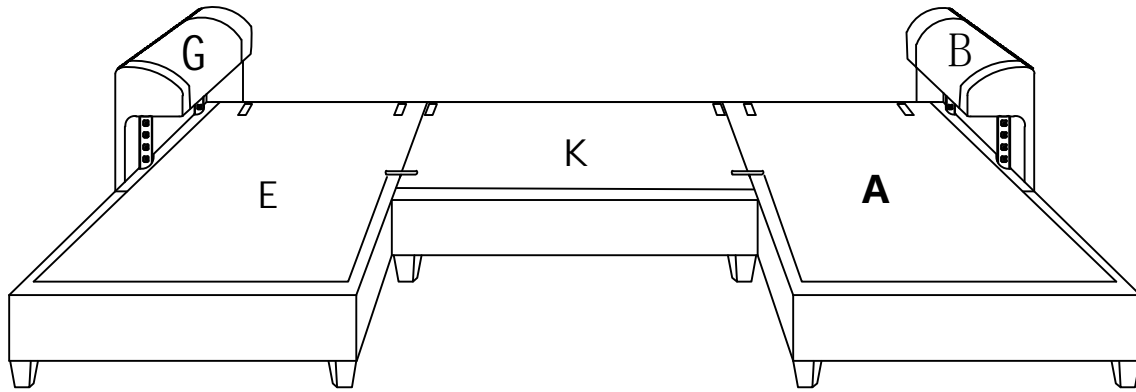

STEP8: Install backrests hardware (part 10-bottom holes) into the seat frame of the sofa

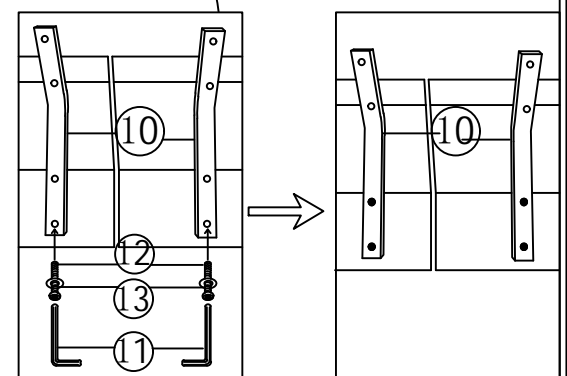
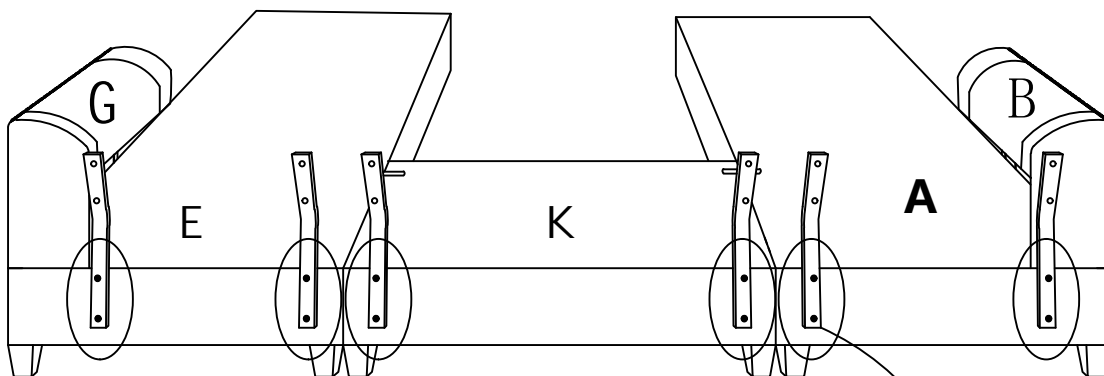

STEP9: Lower the backrests and align their holes with the holes of hardware

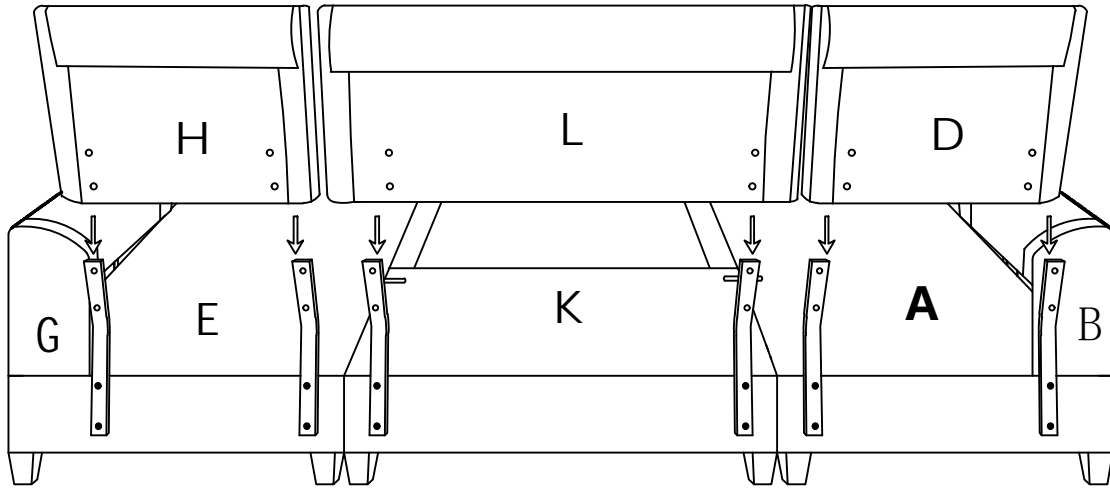

STEP10: Install backrest hardware (top holes)

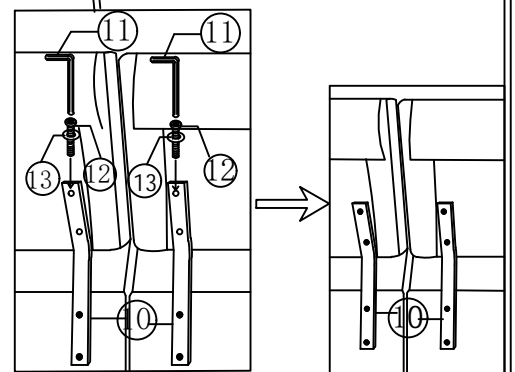
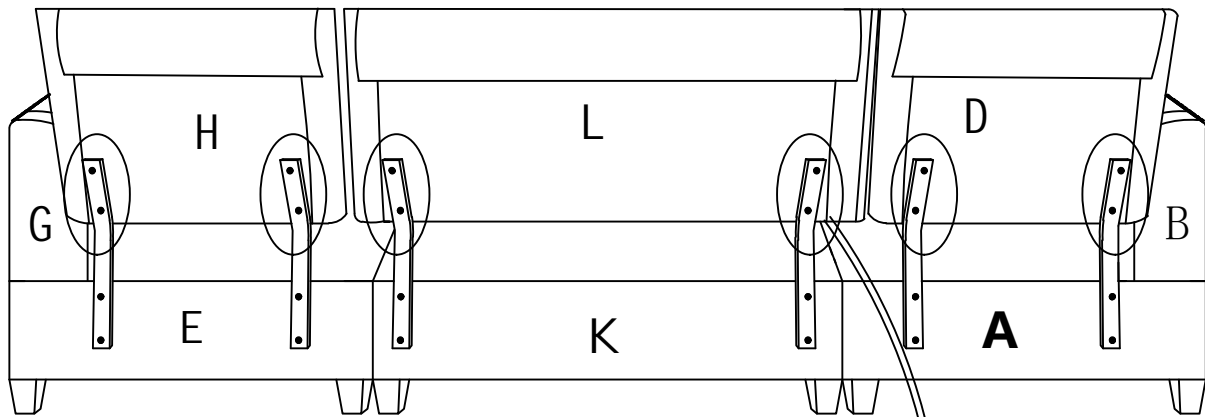

STEP11: Put down the back cloth and stick velcro to the bottom of the seat frame

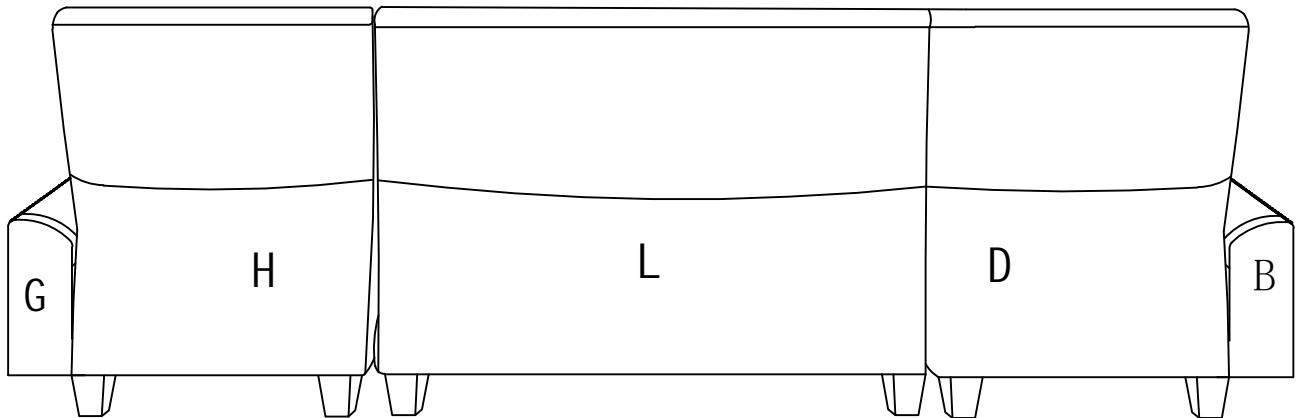
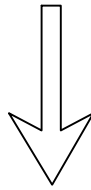

STEP12: Lock backr ests with metal plates (par t 5)

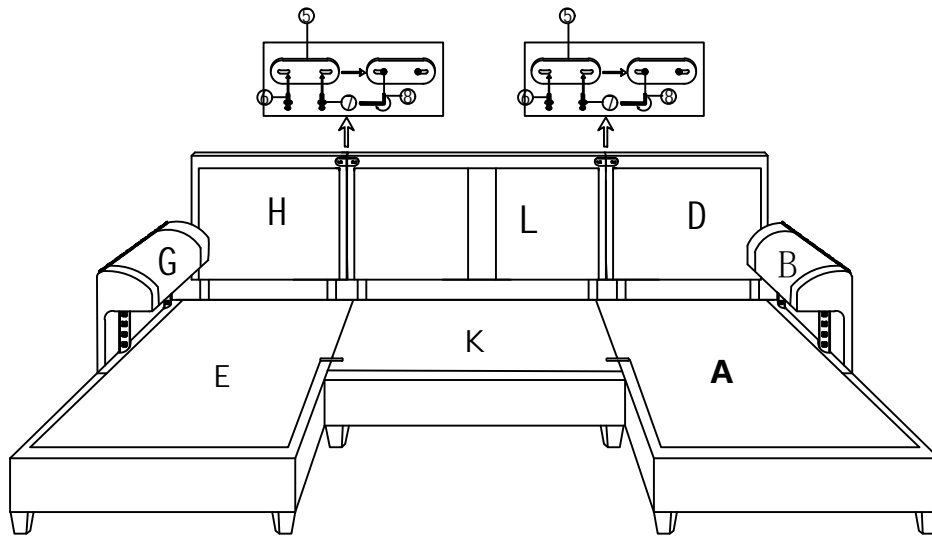

STEP13: Cutting open the compr ession bag.

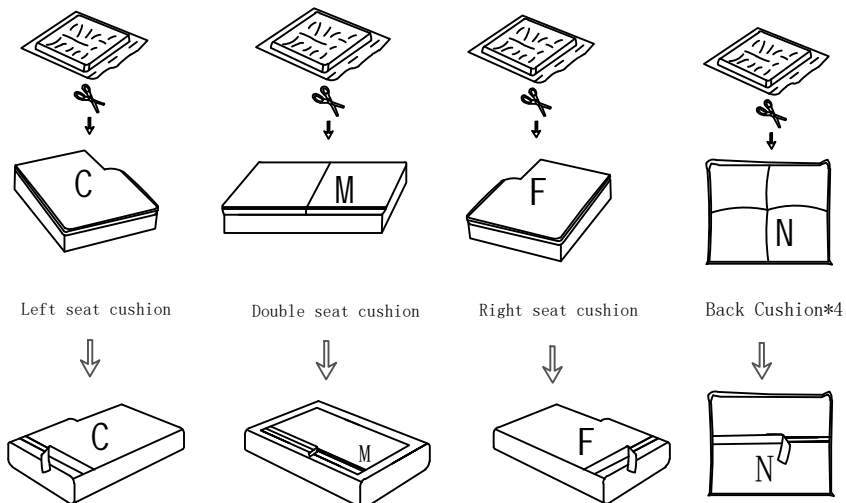

STEP14: Zip the armrest cushion to the armrest

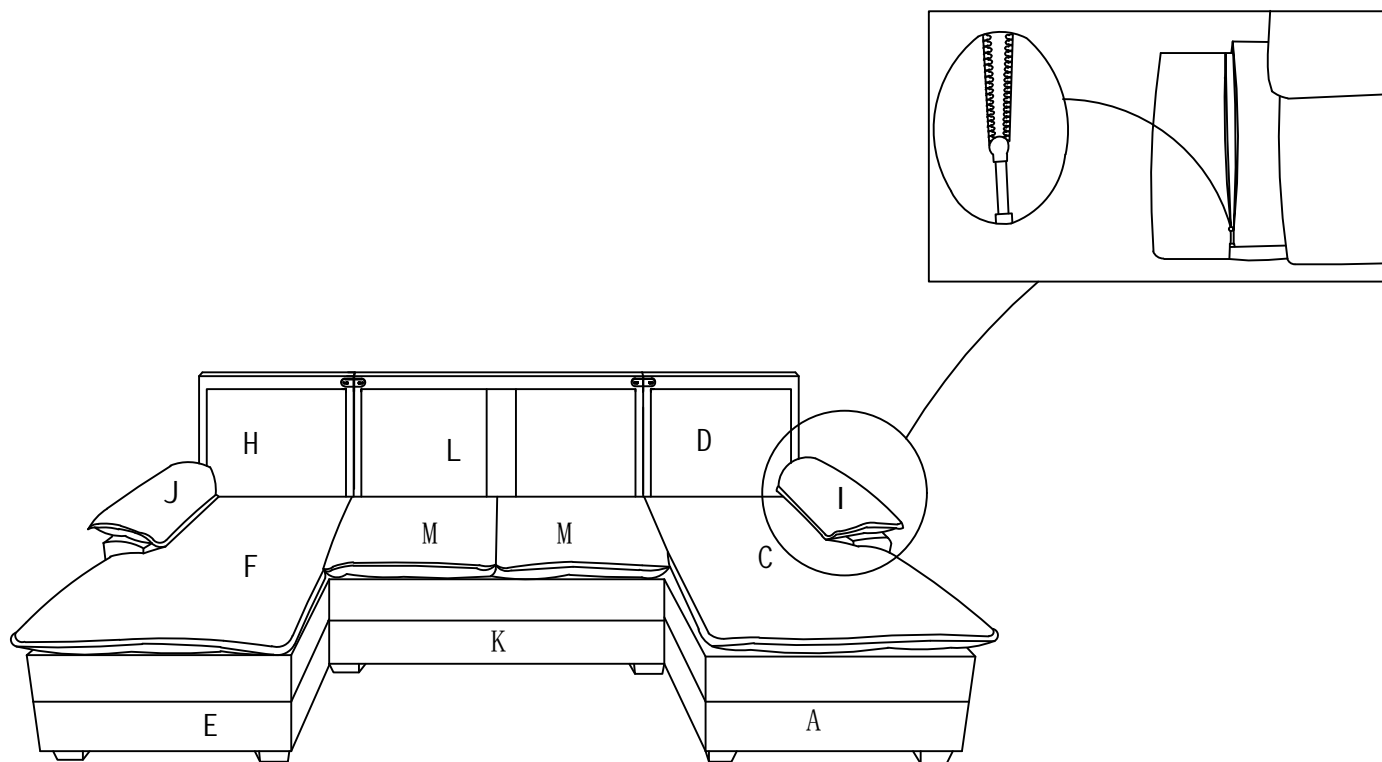

STEP15: Put the upper seat cushion and the back cushions on and the assembly is completed

