

To deodorize the chair, leave it in a shaded and well-ventilated outdoor area for 1-2 days.

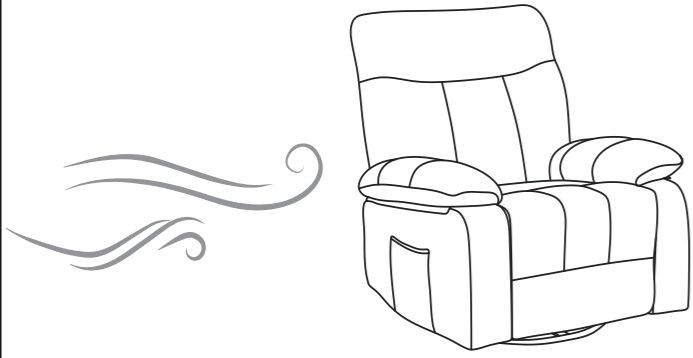

For long-term use, periodically retighten all bolts with the provided Allen Key.  
 Note: Do not use an electric screwdriver, as it may damage the chair. Always tighten the bolts manually.



## Safety Information



Sit in the center of the chair, with your back against the backrest  
 Do not sit on the front edge of the chair  
 Do not stand on the chair  
 Do not use the chair with more than one person  
 Do not push the chair around when a person is sitting in it  
 Do not push down on the backrest when a person is reclined  
 Do not put your full weight on the backrest

- Avoid exposing the furniture to direct sunlight, heating, or air conditioning outlets.
- Do not place your chair too close to windows, radiators, or vents, and be sure to use window treatments to block the sun's rays.
- Do not use rough cleaning tools or corrosive detergents to clean the chair.
- Some parts are heavy and/or have sharp edges. Use caution during assembly to avoid injury to yourself or others.

# INSTRUCTION MANUAL

Model: SF-YZ6070

✉ HJ-Customer-Service@outlook.com  
 ☎ (909)637-7665 | (909)637-7593

# INSTRUCTION MANUAL

## SF-YZ6070



✉ HJ-Customer-Service@outlook.com  
 ☎ (909)637-7665 | (909)637-7593



## Package Contents

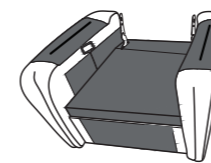

(A)\*1



(B)\*1



(C)\*1(R)



(D)\*1(L)



(E)\*1



(F)\*1

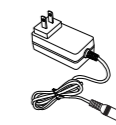

(G)\*1



(H)\*1

# Assembly Instruction

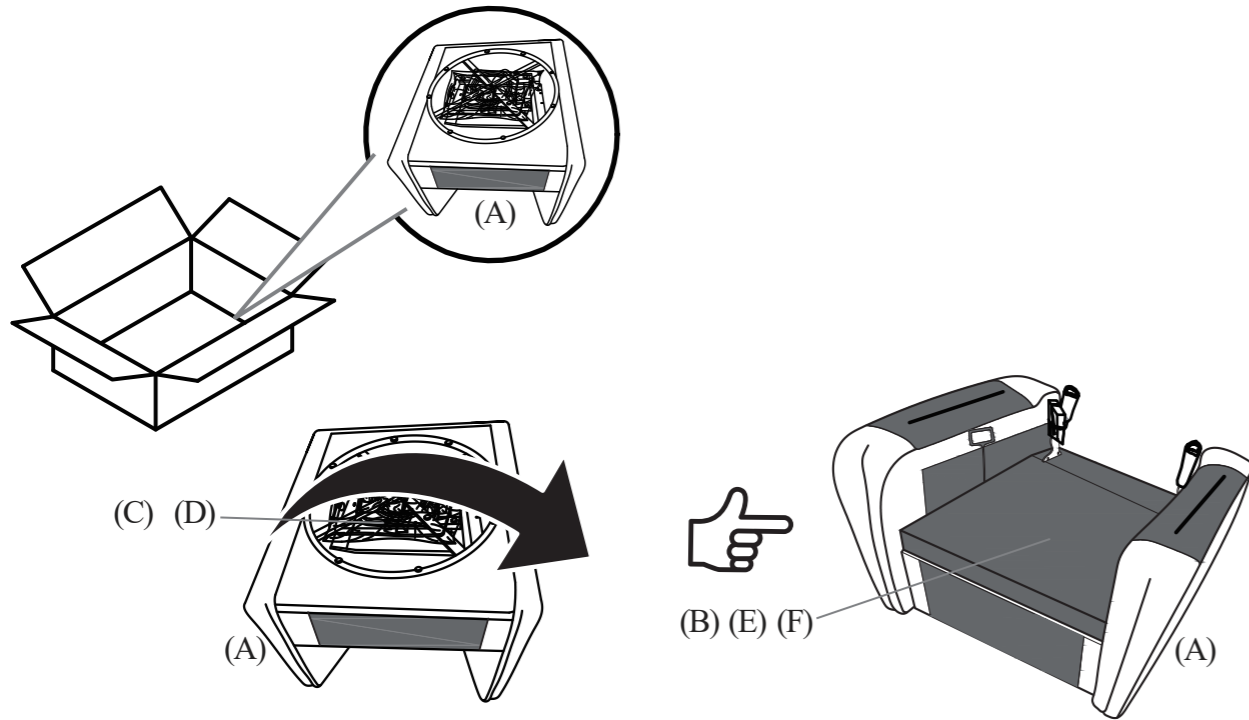

1

**Note:** The two Armrests (C)&(D) are stored under the seat, while the Seat Cushion (B), Back Frame (E), and Backrest (F) are placed on top.

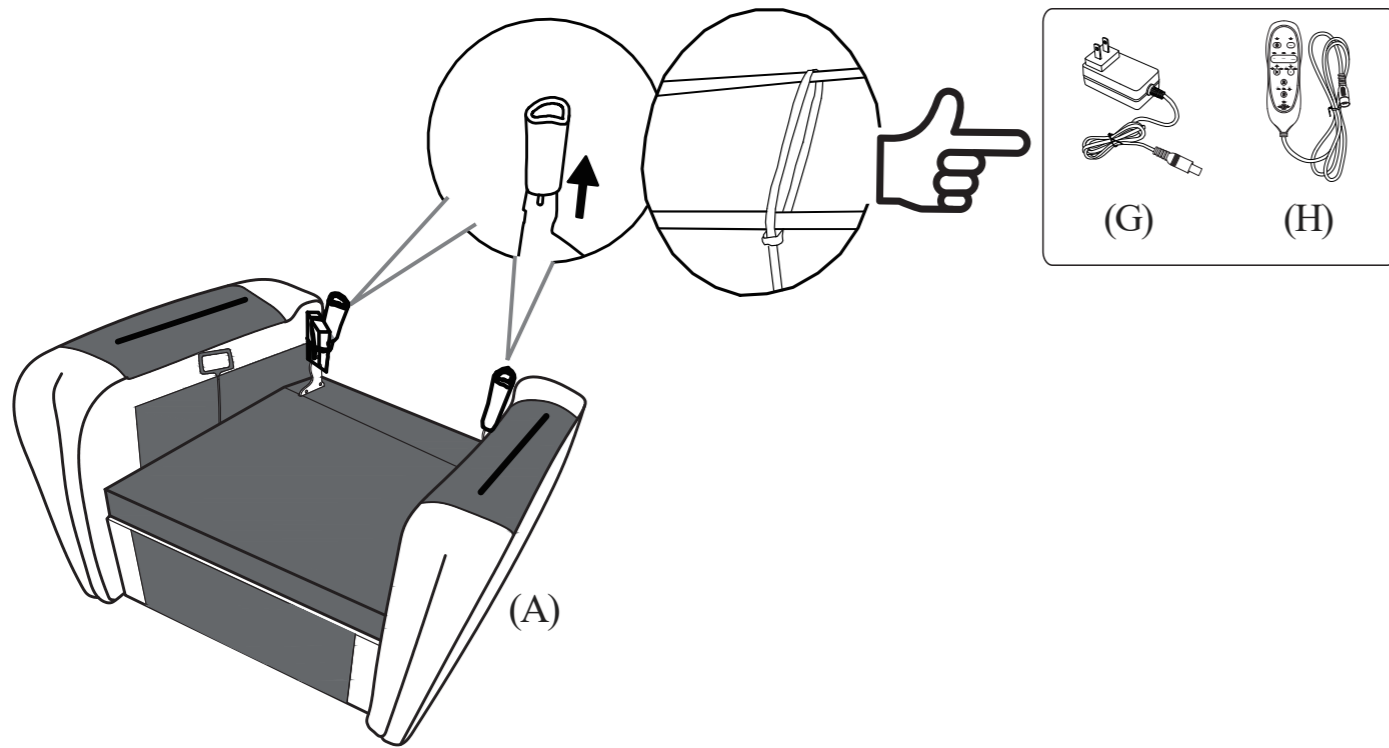

2

**Note:** Remove the packaging material and cut the strip.

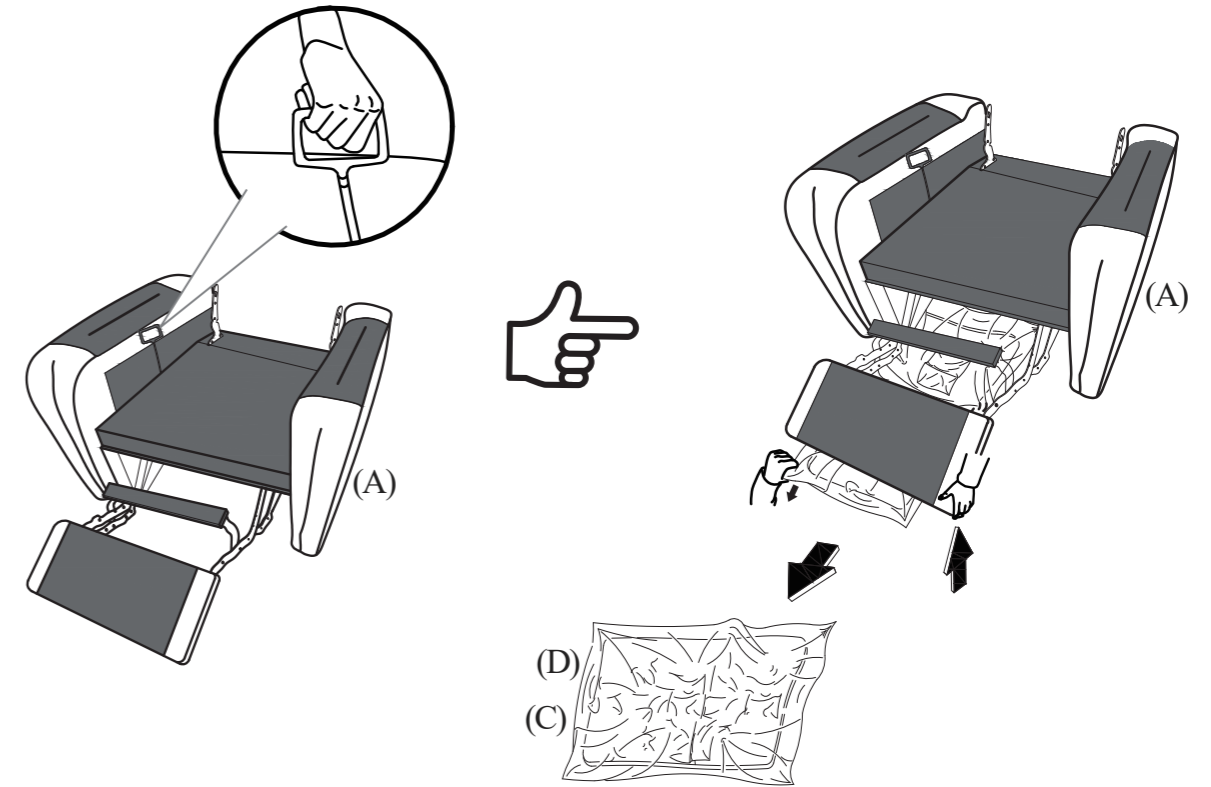

3

**Note:** Pull the handle upward to open the footrest and hold it to take out the Armrests (C)&(D).

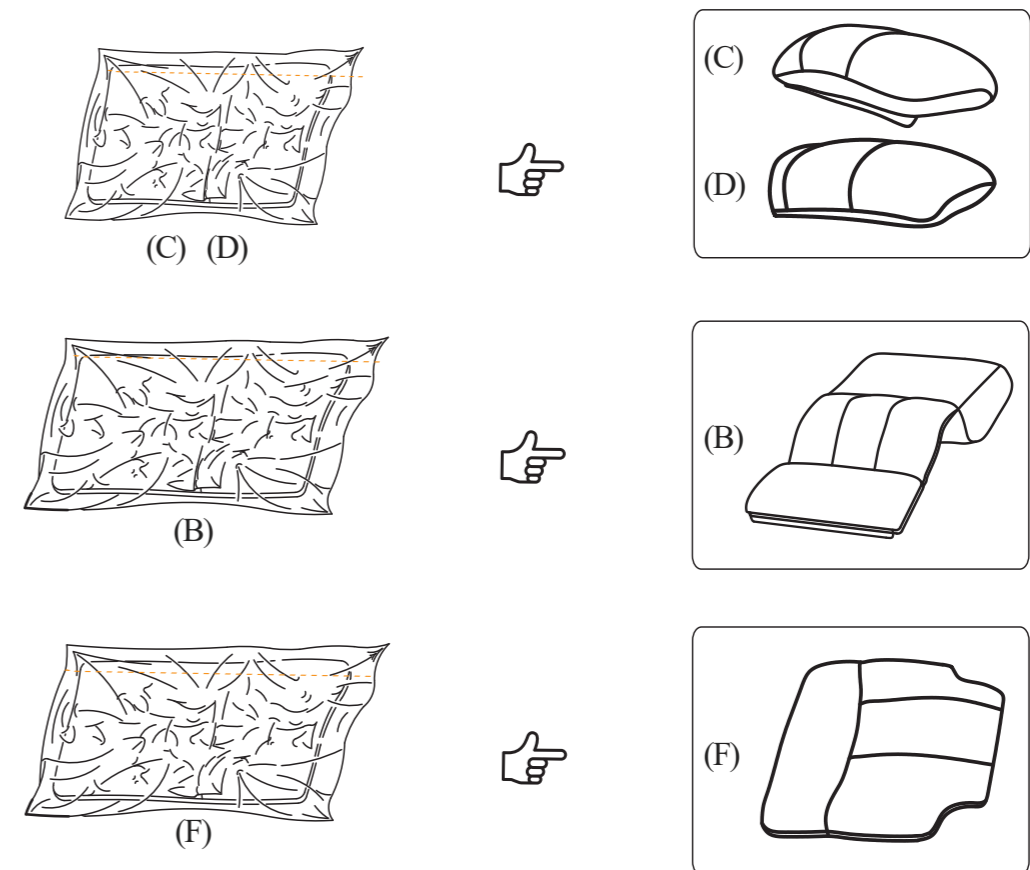

4

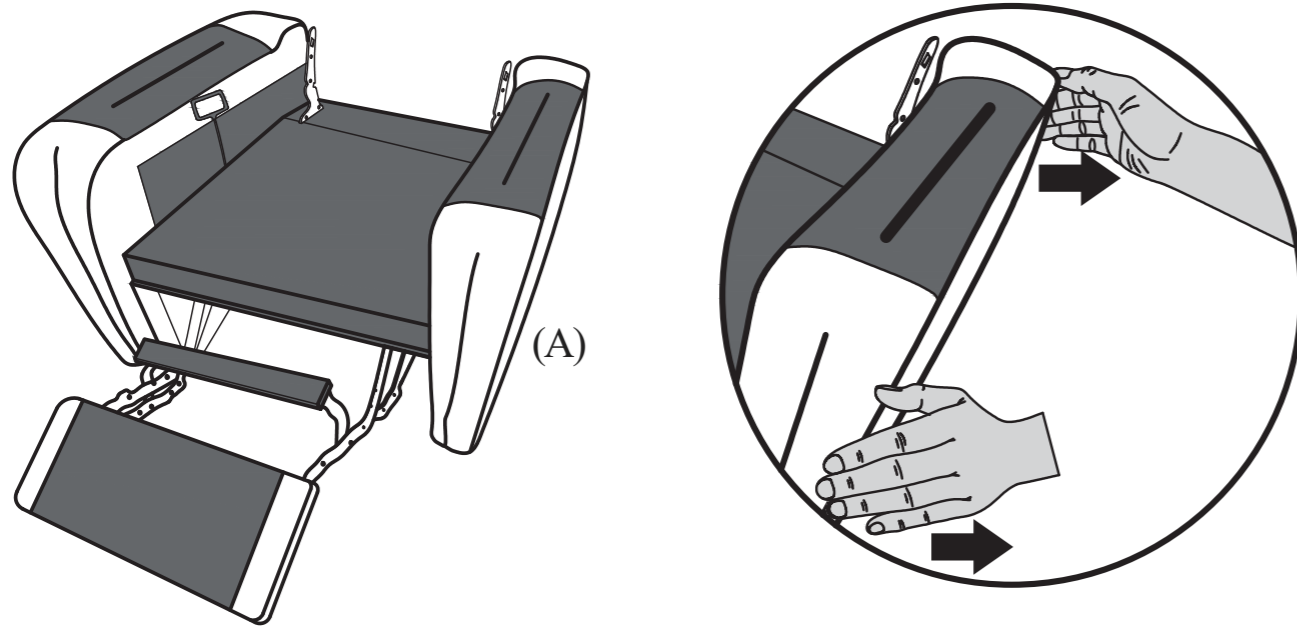

**5** **Note:** Pull the outer side panel of the armrest outward. And repeat it on the other side.

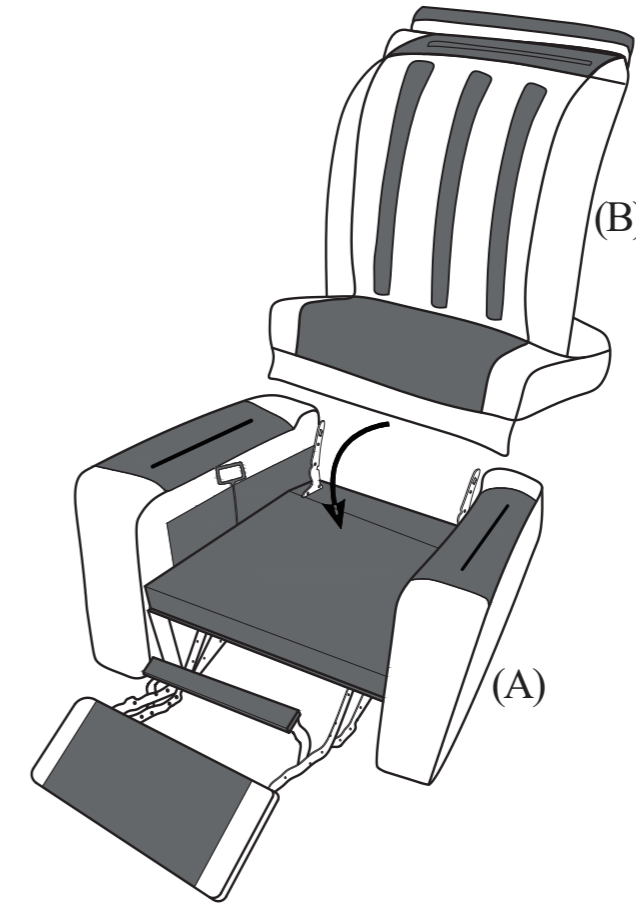

**7**

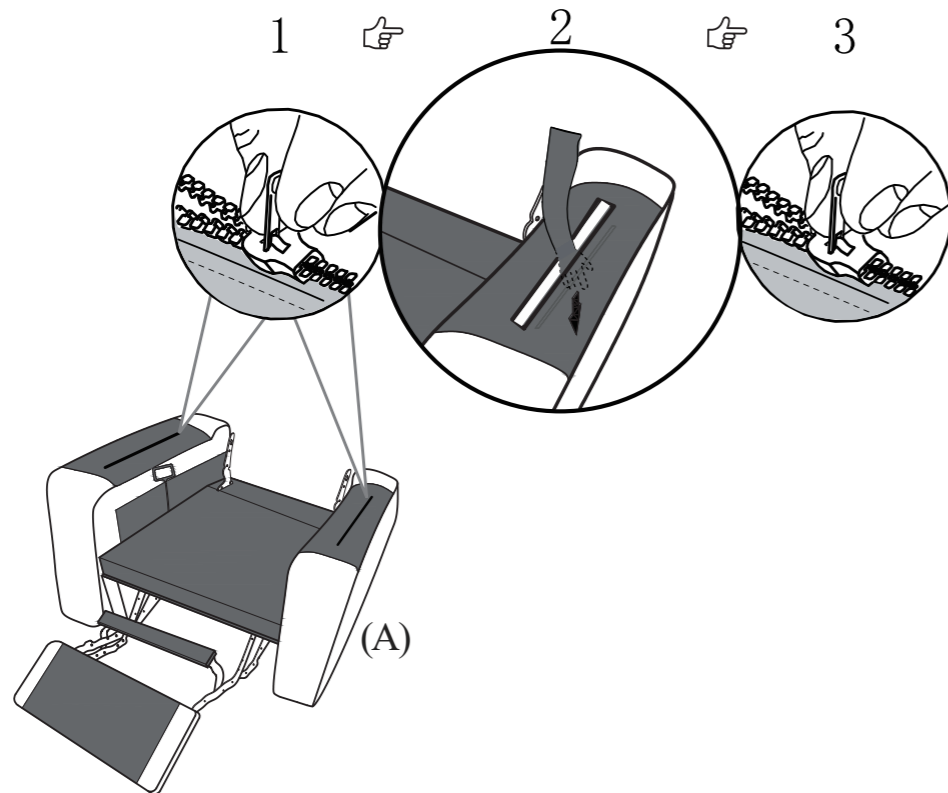

**6** Step 1: Unzip the armrests.  
Step 2: Press the wooden strip downward to secure the armrests.  
Step 3: Zip up.

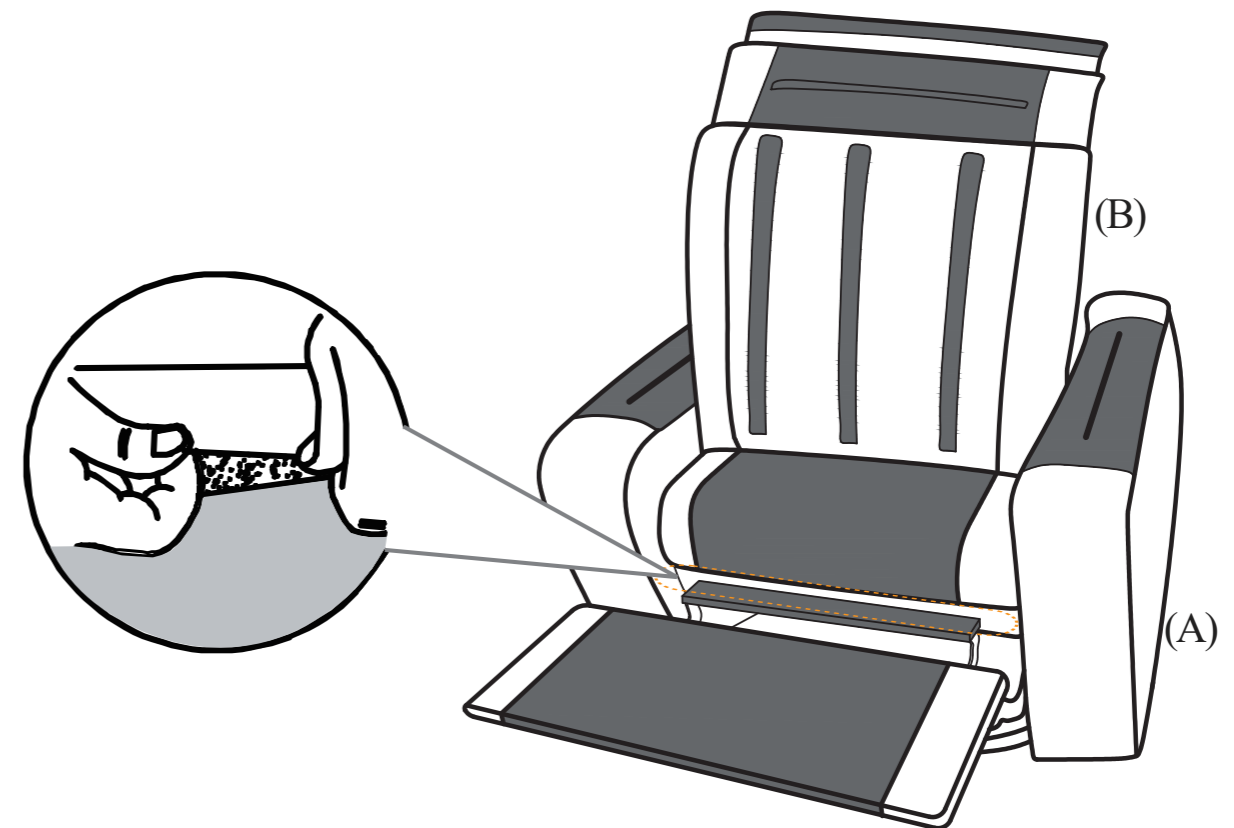

**8** **Note:** Secure the Seat Cushion (B) to the Seat Frame (A) with Velcro.

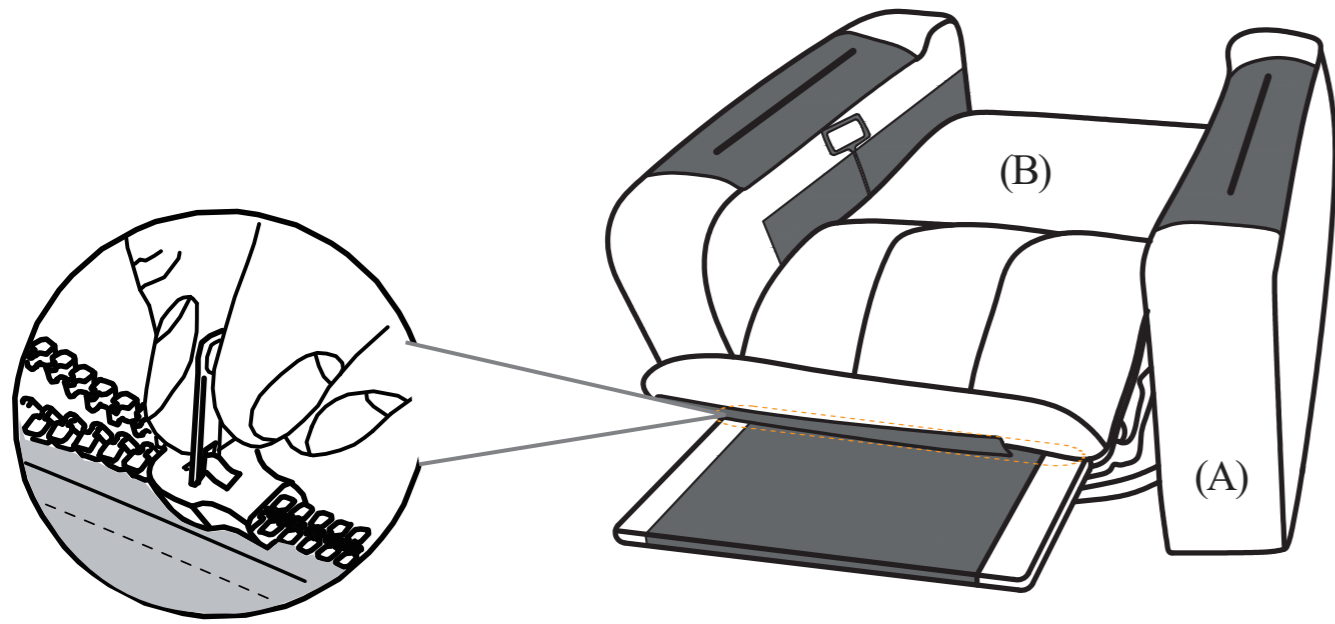

9

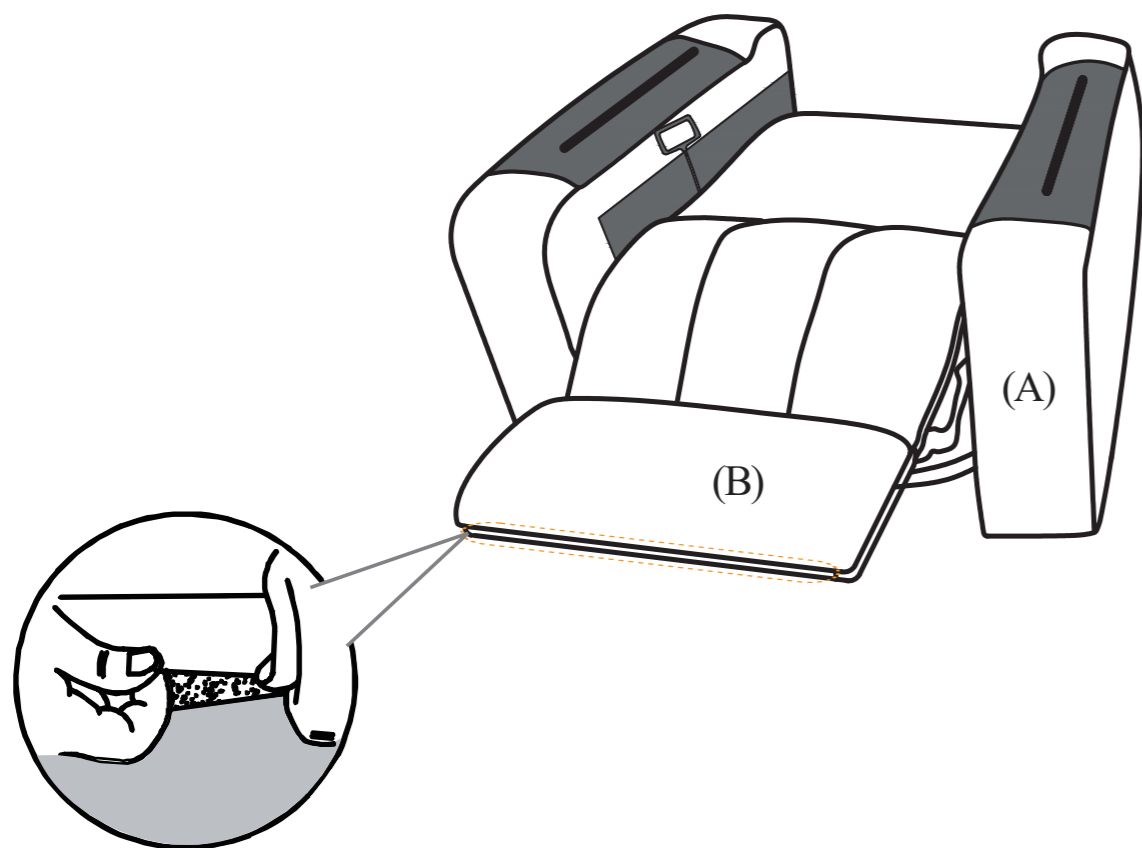

10

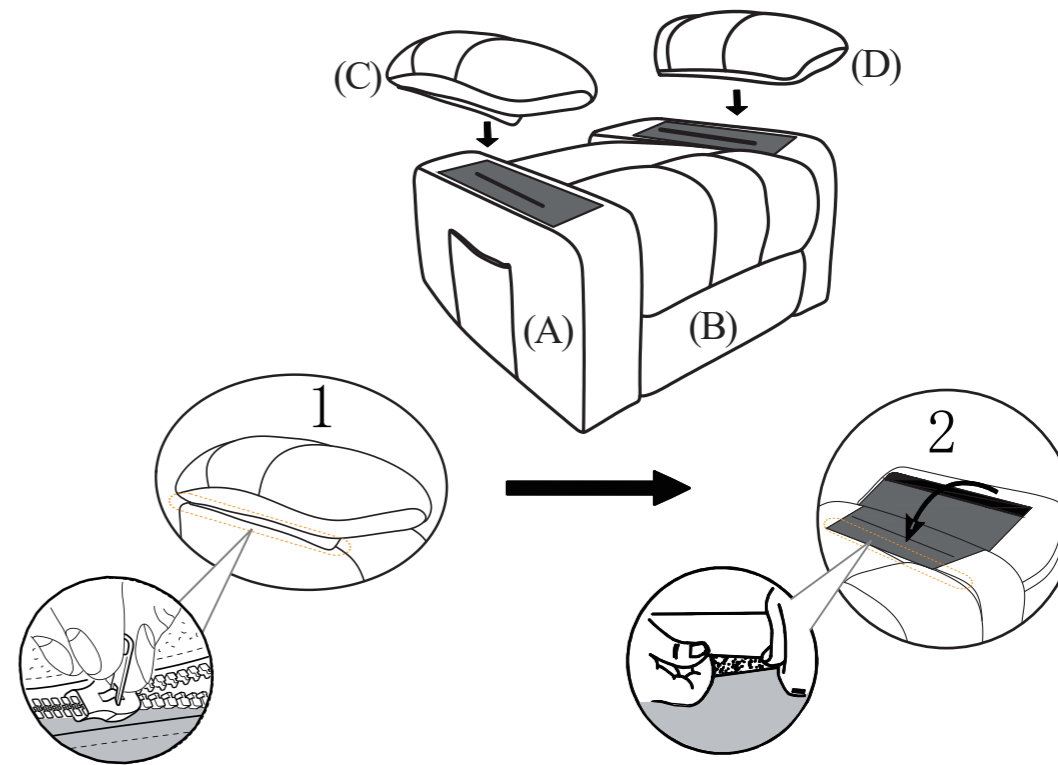

11

Step 1: Align the zipper, then zip it up to secure the Armrests (C)&(D).  
Step 2: Stick the Armrests (C)&(D) to the Seat Frame (A).

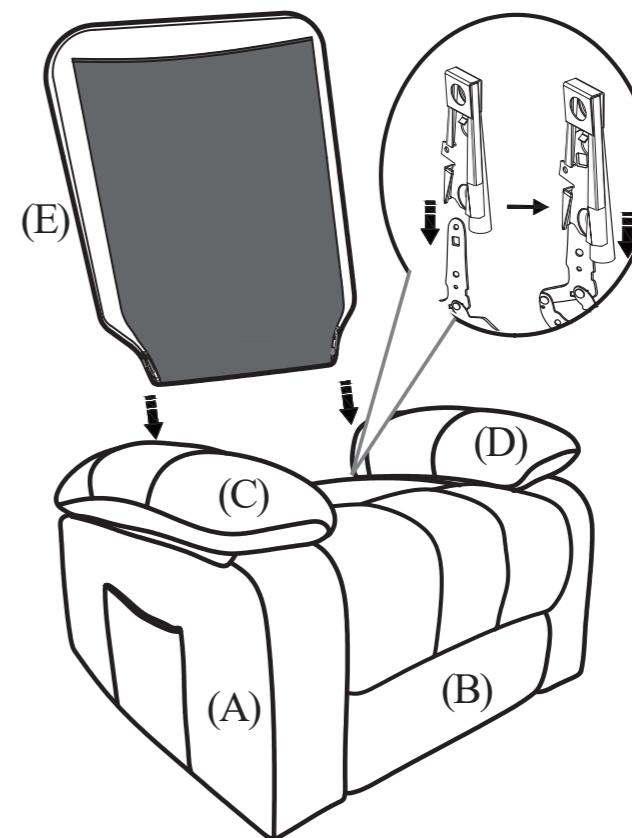

12

**Note:** Push the Back Frame (E) downward until it locks.

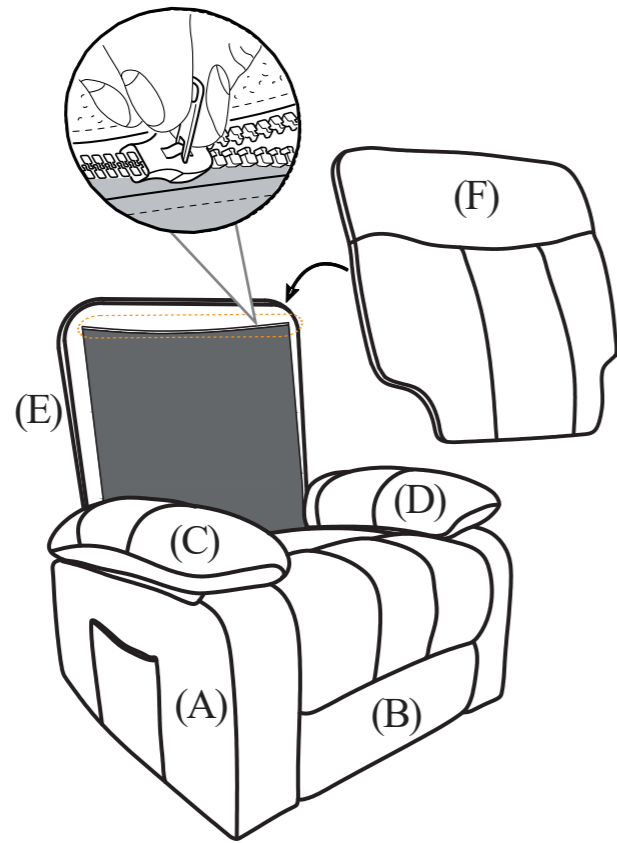

**13** **Note:** Align the zipper, then zip it up to secure the Backrest (F).

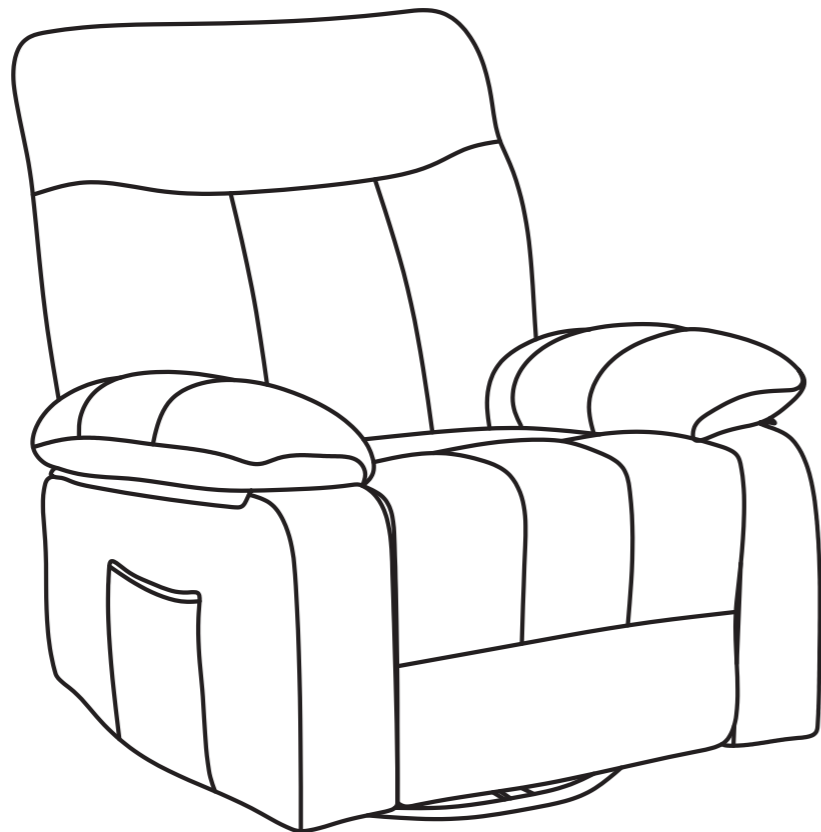

**14**

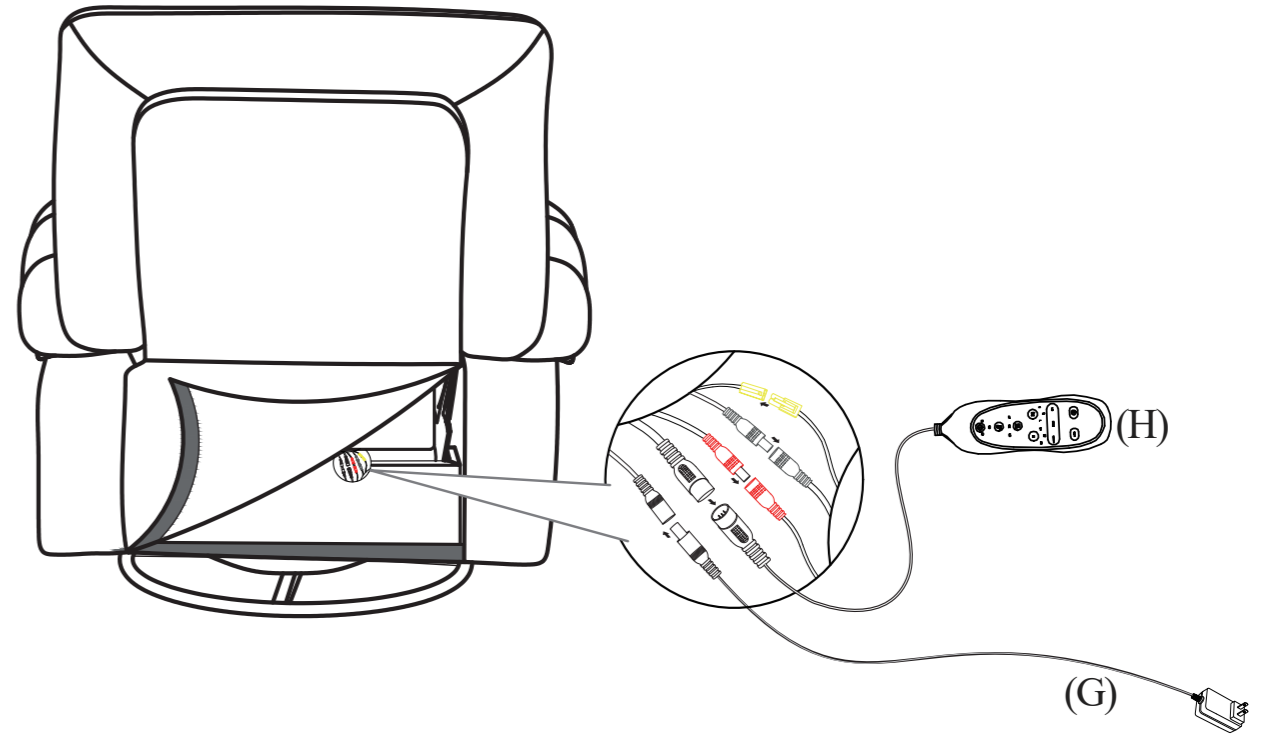

**15** **Note:** Match connectors of the same color only.

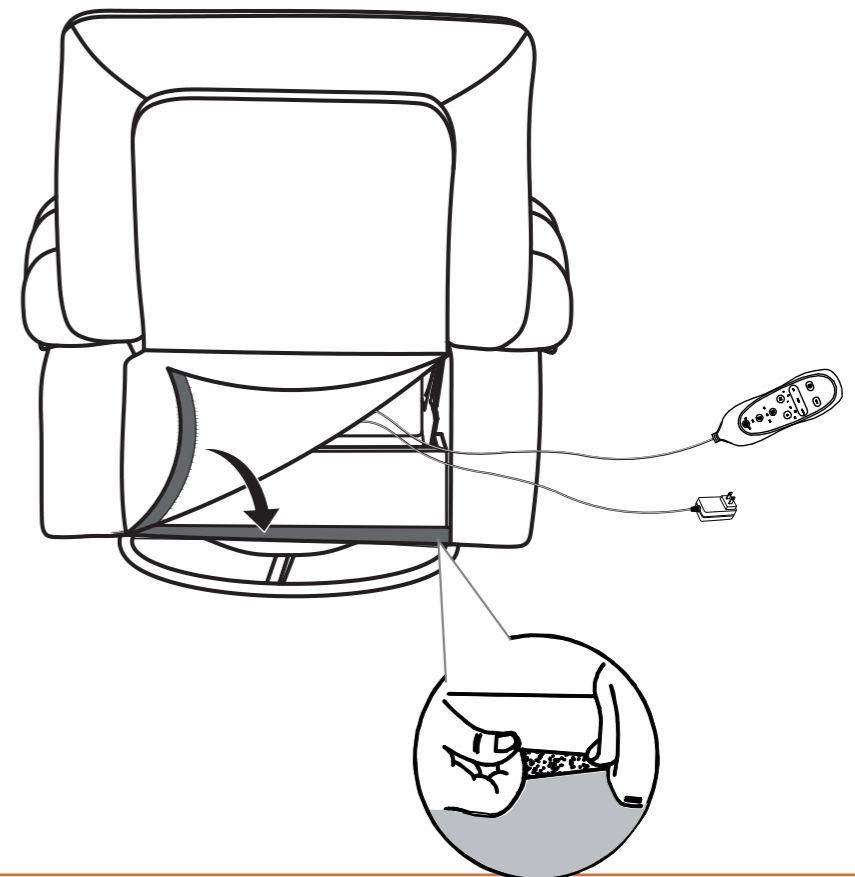

**16**

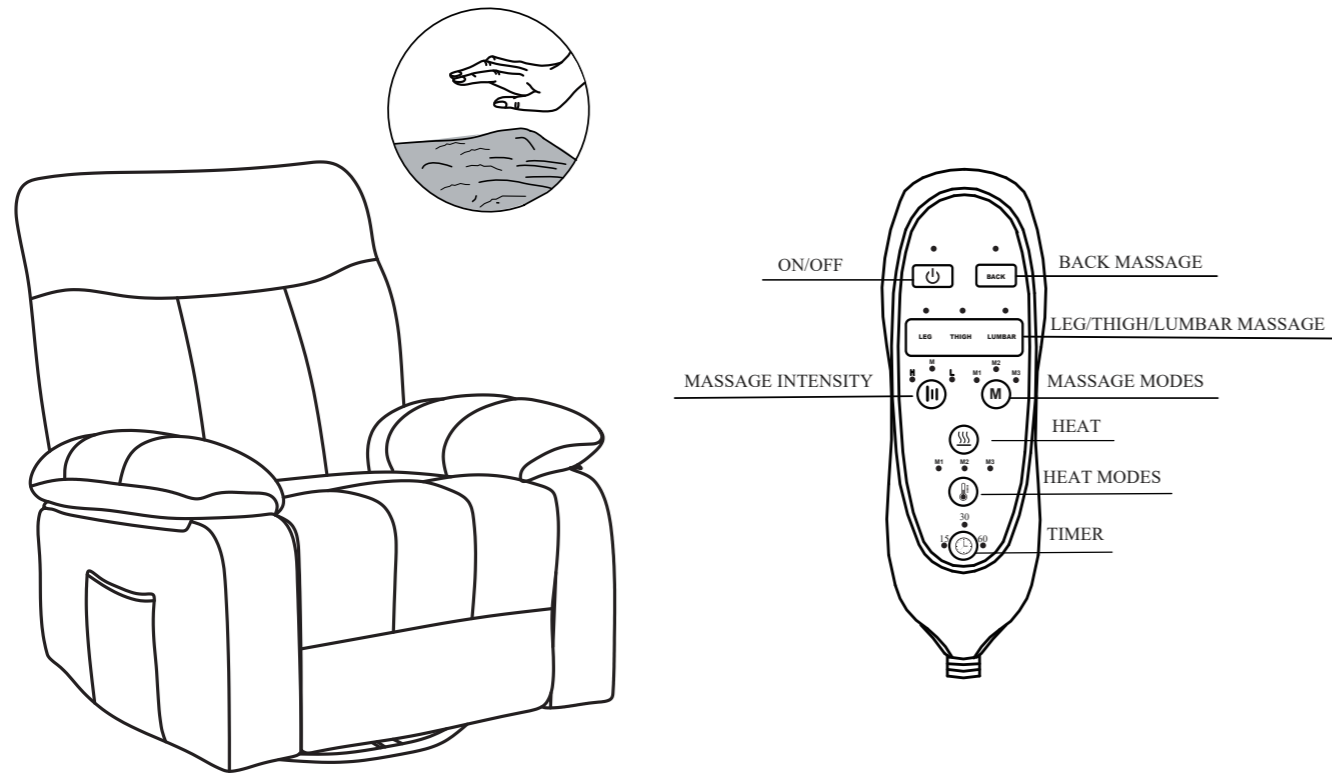

**17** **Note:** After assembly, the surface might have some dents. Pat them and the dents will disappear in 1-2 weeks.

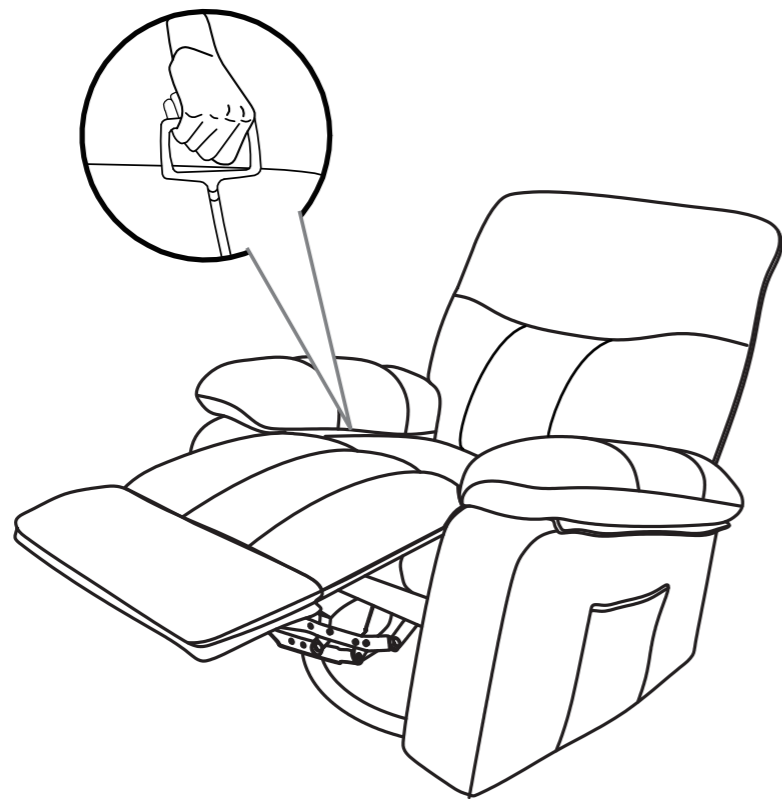

**18** **Note:** Pull the handle to unfold the footrest. And fold the footrest by pressing it with your legs.

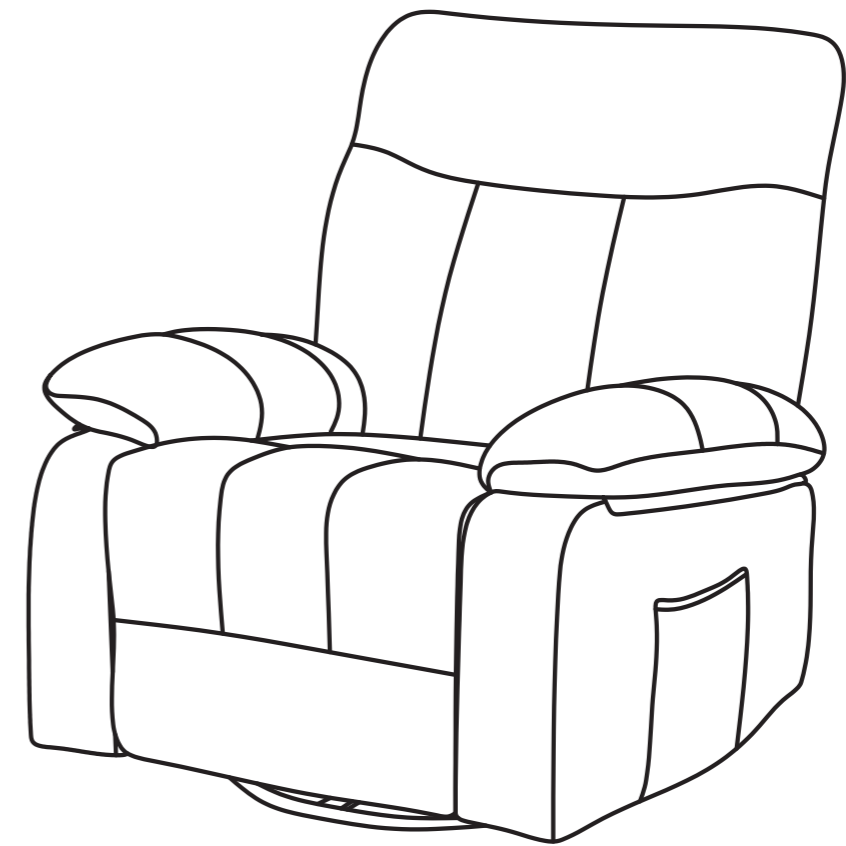

**19**

## Instructions For Use

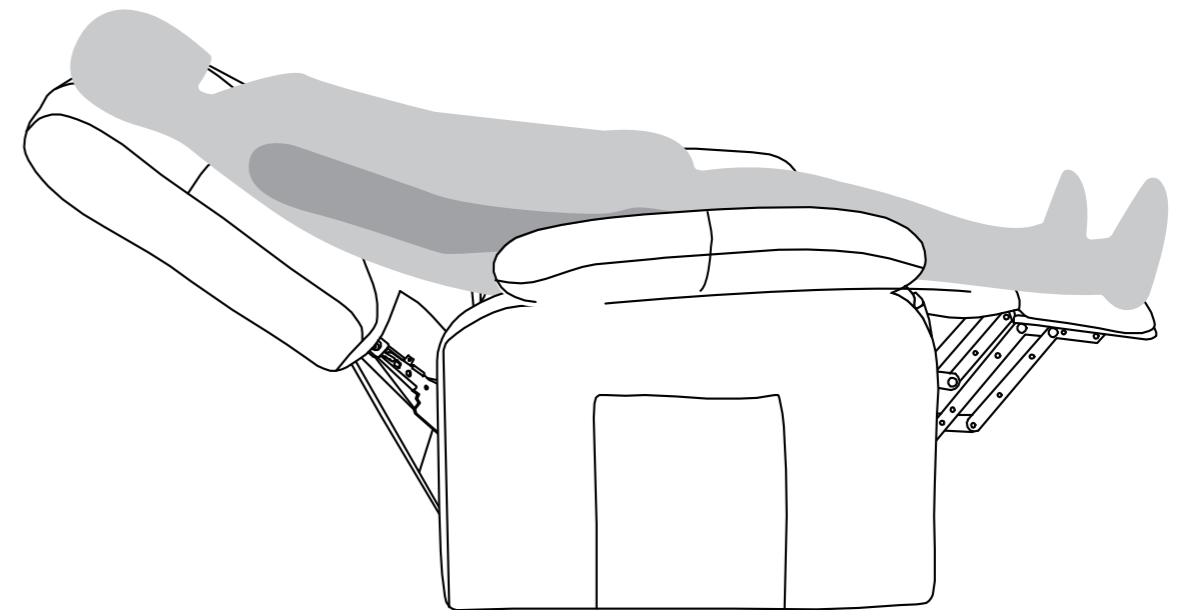

# WIDE ROCKER CHAIR

READ ALL INSTRUCTIONS BEFORE USING THE PRODUCT.

## IMPORTANT SAFETY PRECAUTIONS

When using an electrical appliance, basic precautions should always be followed, including the following:

1. This product is for use on a 12V circuit. Make sure that the product is connected to an outlet having the same configuration as the plug.
2. Always unplug the product from the power source after use, and before cleaning.
3. Do not reach for the product if it has fallen into water. Unplug immediately.
4. The appliance should never be left unattended when plugged in. Unplug from the outlet when not in use.
5. Do not use outdoors.
6. Do not carry this appliance by the supplied cord as a handle.
7. Keep the cord away from heated surfaces.
8. Close supervision is necessary when this appliance is used by, on, or near children, invalids or disabled persons.
9. This unit is not a toy. Children should not use it or play with it.
10. Do not operate where aerosol (spray) products are being used or where oxygen is being administered.
11. Do not use near eyes or other highly sensitive areas.
12. To disconnect, press ON/OFF button again and ensure the corresponding indicator light is off. Make sure all functions are stopped, then unplug it.
13. Use this appliance only for its intended use as described in this manual. Do not use attachments not provided with the unit.

## WARNINGS

- If you have any underlying health conditions, consult your doctor before using this product.
- Do not use this product if you have a pacemaker.
- If you experience persistent pain in a muscle or joint, discontinue use and consult your doctor. This could be a symptom of a more serious condition.

## CONTROL PANEL

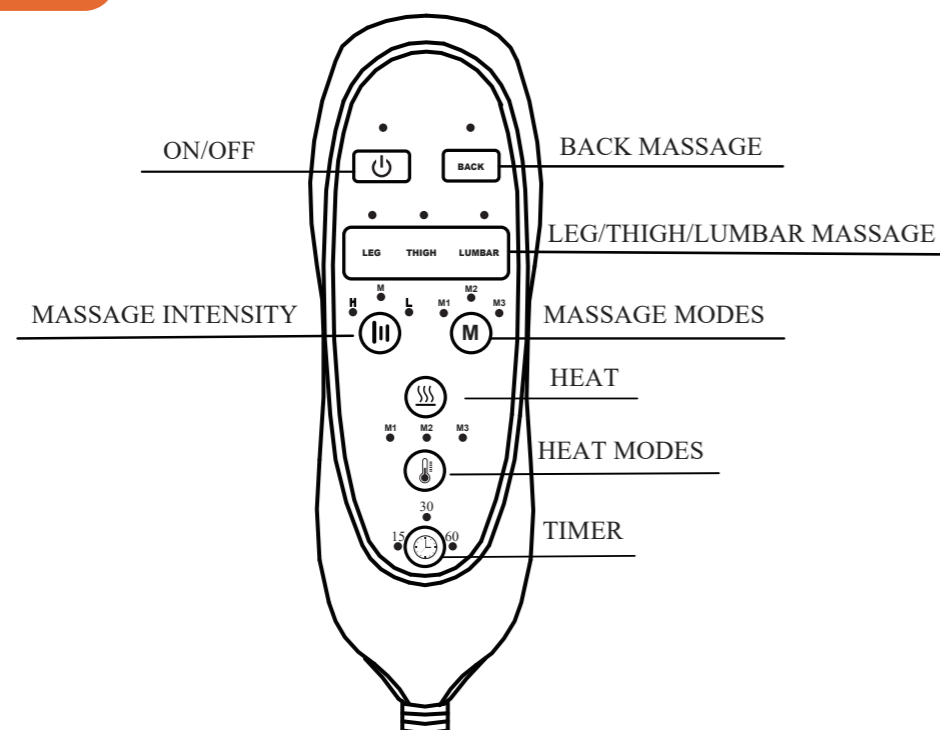

## Technical Specifications:

- 1.Voltage: DC12V
- 2.Current: 1A
- 3.Power: 12W
- 4.Voltage Grade: Class III
- 5.Frequency:50-60Hz

## PRODUCT FEATURES

- 3 Heat Modes
- 8 Vibration Motors
- 3 Massage Modes
- 3 Massage Intensity Levels
- 4 Massage Zones (each zone can be operated individually)
- 3 Timer Settings: 15 / 30 / 60 minutes

## OPERATING INSTRUCTIONS

1. Connect the charging cable to the DC input port of the chair, then plug the power adapter into a wall outlet.

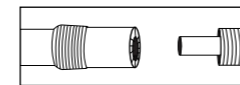

2. To turn the unit on, press the ON/OFF button (⏻) and the corresponding indicator light will illuminate. The default massage intensity is medium, the massage mode is M1, and the timer is 15 minutes. To turn off the device, press the ON/OFF button again. The heat function is controlled separately. When you press the HEAT MODES button, the default heat mode is M1. To turn off the heat function, press the button again.
3. To activate massage for a specific body zone, press its corresponding button (BACK, LEG, THIGH or LUMBAR (LEG THIGH LUMBAR)). Indicator lights will illuminate when each zone is activated. To turn off the zone, press the button again. These buttons can also be used simultaneously.
4. To choose a desired massage mode, press the MASSAGE MODES button (M). The M1 mode features intermittent strong and weak cyclic vibrations in the back, lumbar, thighs and legs. The M2 mode provides continuous vibrations in the back, lumbar, thighs and legs. The M3 mode offers cyclic vibrations in the lumbar and thighs. To change modes, press the MASSAGE MODES button until the indicator light for the desired mode illuminates.  
**PULSE (M1)**---for deep tapping massage  
**PRESS (M2)**---for rapid tapping massage  
**WAVE (M3)**---for a gradual, side-to-side vibrating massage
5. To change the massage intensity, press the MESSAGE INTENSITY button (H, M, L). The indicator light for High, Mid or Low intensity will illuminate when pressed.  
**NOTE:** Do not use it immediately if you feel any discomfort or pain.
6. For your benefit, the Wide Rocker Chair is equipped with an auto shut-off feature. You can pull the ring inside the armrest to activate it.
7. Press the HEAT button (🔥) to turn on the heat mode. And press HEAT MODES (M1, M2, M3) to select your desired heat temperature among M1, M2, M3.
8. Press TIMER (🕒) to choose your desired time:15, 30, 60 min.
9. Do not use it for more than 60 minutes continuously.

## MAINTENANCE

### TO STORE:

Store the unit in its box or a safe, dry, cool place. Avoid contact with sharp edges which might cut or puncture it. Do not wrap the power cord around the unit. Do not hang the unit by the power cord.

### TO CLEAN:

- Always ensure the unit is unplugged and has cooled down before cleaning.
- Do not immerse the unit in any liquid. Clean it by wiping it with a damp sponge with a mild detergent or suds. Dry it with a clean, dry cloth.
- Do not use abrasive cleaners, brushes, gasoline, kerosene, glass /furniture polish, paint thinner, or any strong chemical cleaners.