

Assembly | Asambla | Assemblage

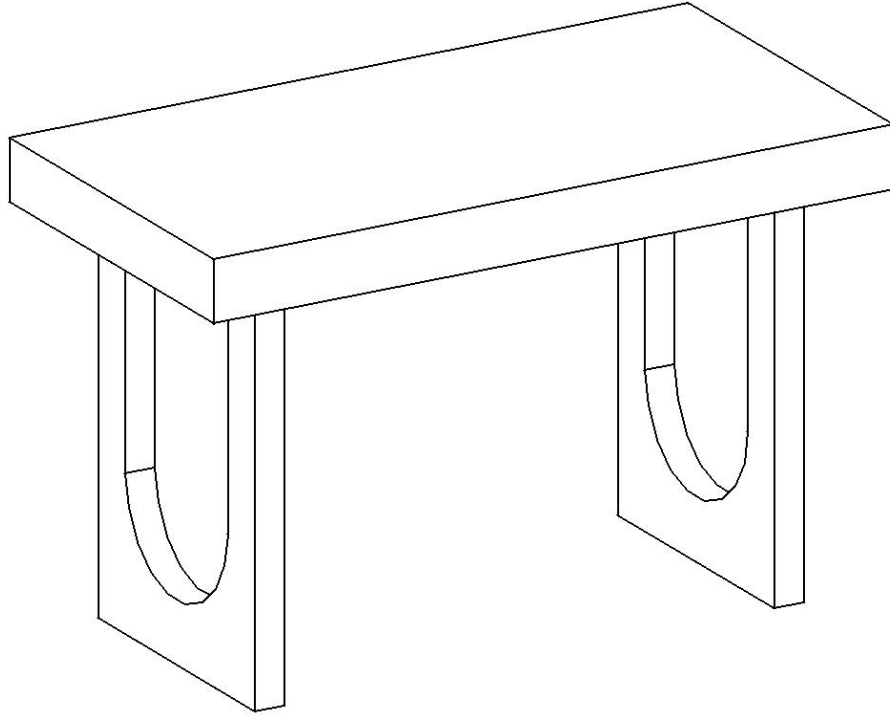

Assembly | Asamblea | Assemblage

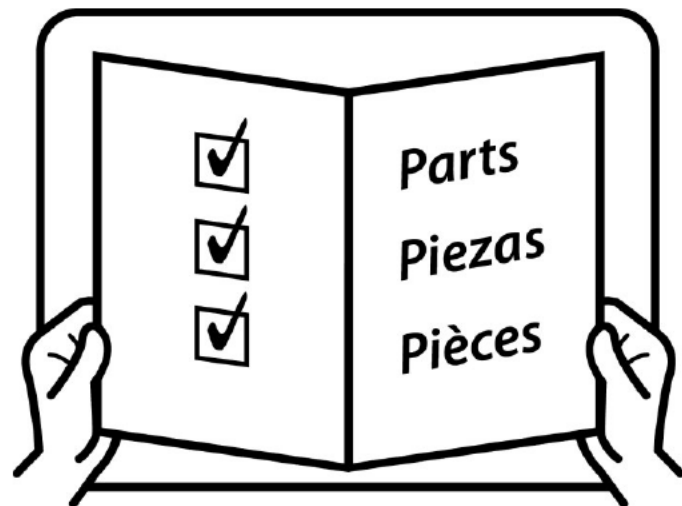
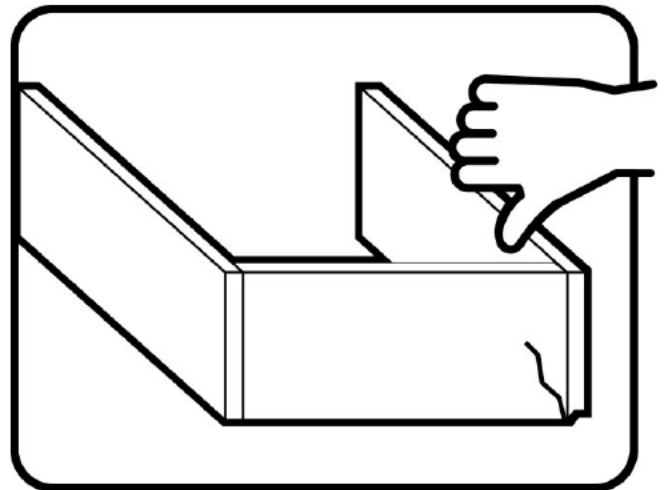
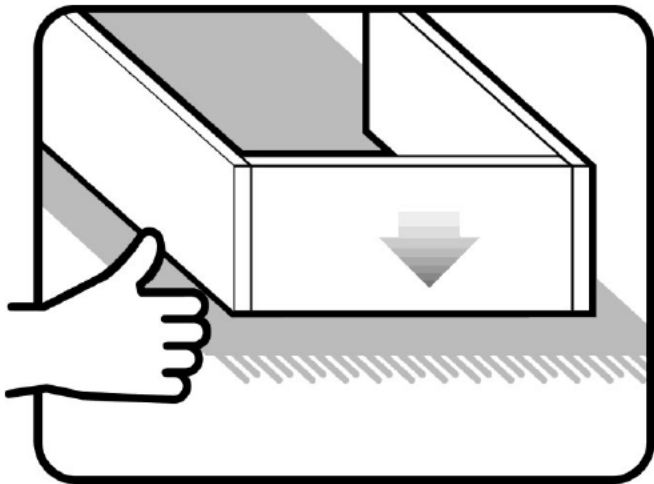
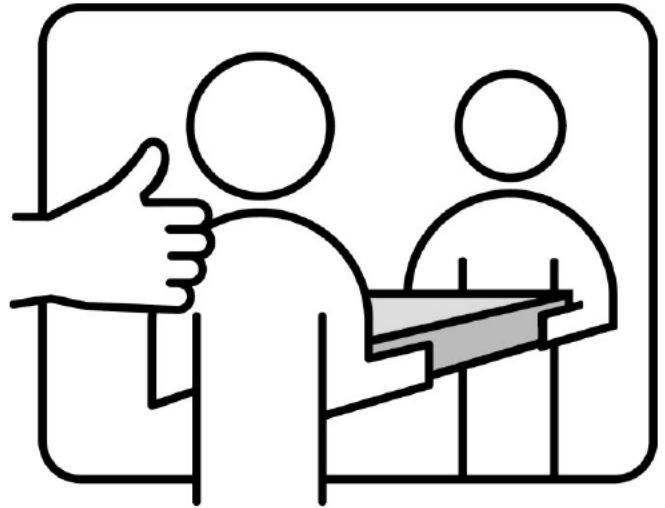
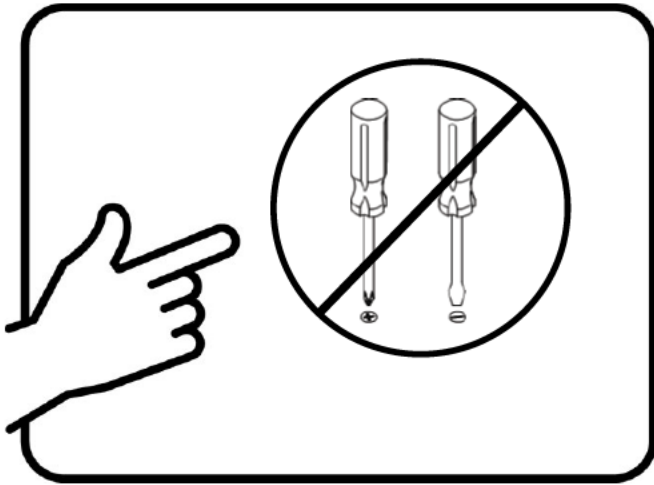

Assembly | Asamblea | Assemblage

Techniques | Técnicas | Techniques

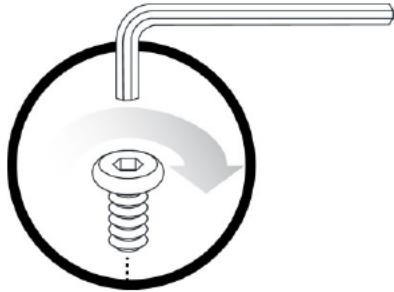

Care | Cuidado | Entretien



Safety | Seguridad | Sécurité







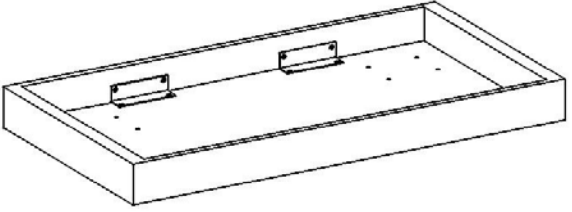
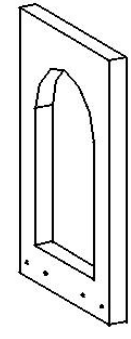

Note! | ¡Nota! | Remarque!

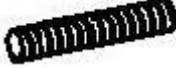

Assembly | Asambla | Assemblage



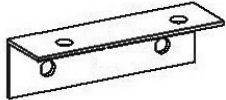

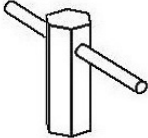
<p>A</p> <p>x1</p>  <p>Top panel Panel superior Panneau du haut</p>	<p>B</p> <p>x2</p>  <p>Leg Pierna Jambe</p>
--	--

Assembly | Asamblea | Assemblage

<p>1 x16</p>  <p>Bolt Tornillo Boulon M6x16mm</p>	<p>2 x8</p>  <p>Bolt Tornillo Boulon M8x80mm</p>	<p>3 x16</p>  <p>Flat washer Arandela plana Rondelle plate M6xΦ16mm</p>
<p>4 x16</p>  <p>Flat washer Arandela plana Rondelle plate M8xΦ18mm</p>	<p>5 x16</p>  <p>Nut Tuerca Écrou M8</p>	<p>6 x8</p>  <p>Bracket Soporte Support 130x50mm</p>
<p>7 x1</p>  <p>Allen wrench Llave allen Clé allen Φ4</p>	<p>8 x2</p>  <p>Spanner Llave Clé M8</p>	

Assembly | Asambla | Assemblage

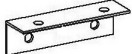
1

2		X8
4		X16
5		X16
6		X8
8		X2

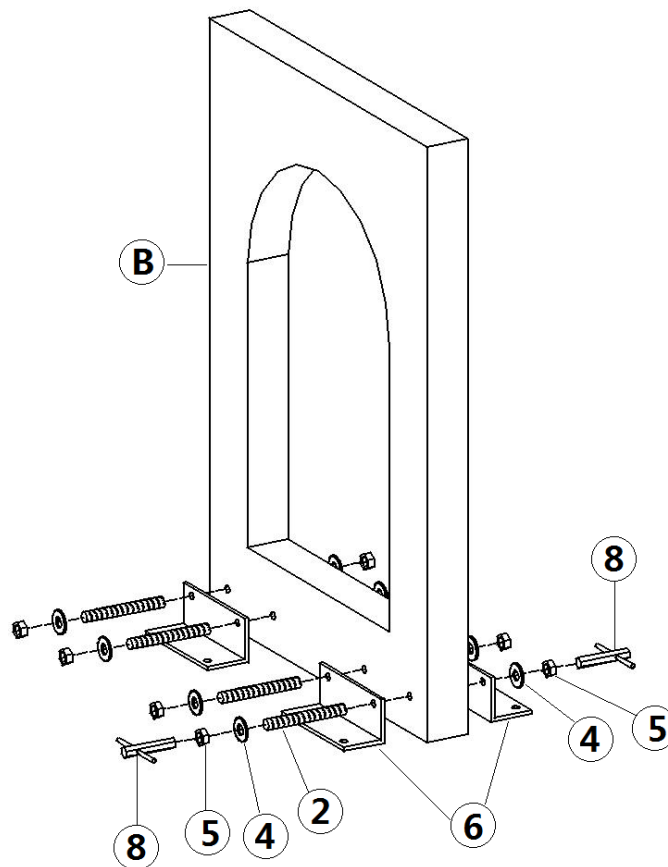

Assembly | Asamblea | Assemblage

2

Do not fully tighten screws until all screws are in position.

No apriete completamente los tornillos hasta que estén en su posición.

Ne serrez pas complètement les vis tant que toutes les vis ne sont pas en place.

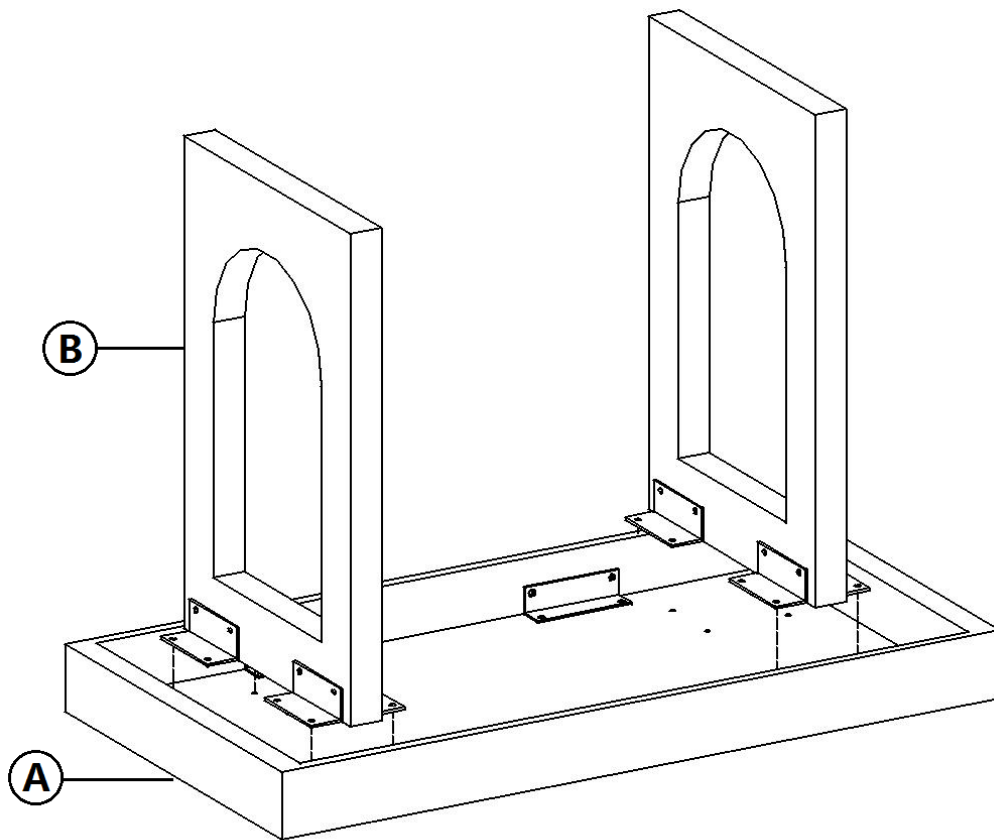



Assembly | Asambla | Assemblage

3

Tighten all screws.

Apretar todos los tornillos.

Serrez toutes les vis.

1		X16
3		X16
7		X1

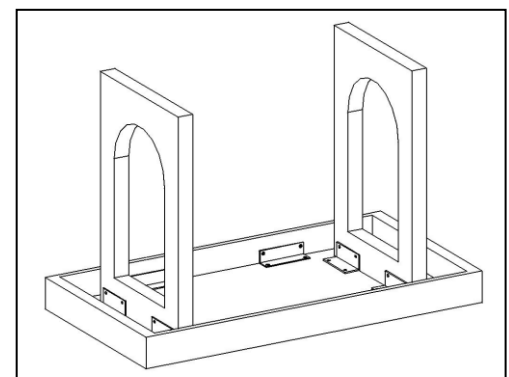
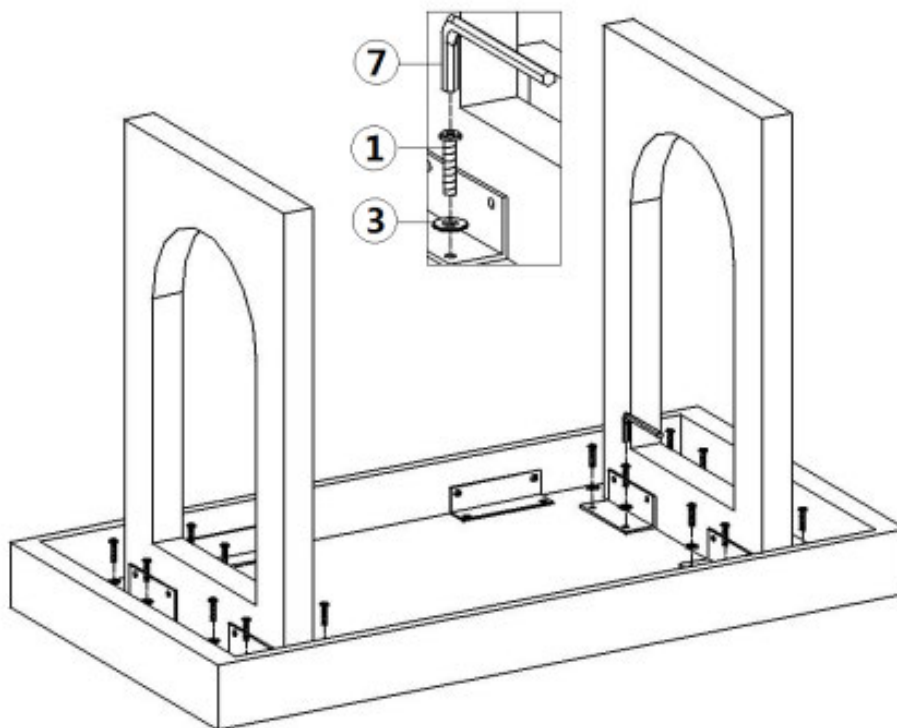

Assembly | Asamblea | Assemblage

Immediately examine this product carefully. Any request for missing or damaged part replacement must be received within 90 days of your receipt of the product. Requests for replacement parts, if available, will be honored within this time frame. Parts will not be available for items arriving fully assembled. We do not recommend modifying products and we are not responsible for any damages due to product modifications. If damages or missing parts are not reported within 90 days of receiving the product, we are under no obligation to provide parts or replacement merchandise.

Please note, for items purchased in a retail store, you will need to contact the retailer for all part needs.

Products purchased at garage sales or discount stores are sold as-is and are not covered by the above warranty

Inmediatamente examine este producto con cuidado. Cualquier solicitud de reemplazo de piezas faltantes o dañadas debe recibirse dentro de los 90 días posteriores a la recepción del producto. Las solicitudes de repuestos, si están disponibles, serán atendidas dentro de este marco de tiempo. Las piezas no estarán disponibles para los artículos que lleguen completamente ensamblados. No recomendamos modificar los productos y no nos hacemos responsables de los daños debidos a las modificaciones del producto. Si no se informan daños o piezas faltantes dentro de los 90 días de haber recibido el producto, no estamos obligados a proporcionar piezas o productos de reemplazo.

Tenga en cuenta que, para los artículos comprados en una tienda minorista, deberá comunicarse con el minorista para todas las necesidades de piezas.

Los productos comprados en las ventas de garaje o tiendas de descuento se venden tal como están y no están cubiertos por la garantía anterior.

Immédiatement examiner ce produit soigneusement. Toute demande de remplacement de pièce manquante ou endommagée doit être reçue dans les 90 jours suivant la réception de votre produit. Les demandes de pièces de rechange, si elles sont disponibles, seront honorées dans ce délai. Les pièces ne seront pas disponibles pour les articles arrivant complètement assemblés. Nous ne recommandons pas de modifier les produits et nous ne sommes pas responsables des dommages causés par des modifications du produit. Si les dommages ou les pièces manquantes ne sont pas signalés dans les 90 jours suivant la réception du produit, nous ne sommes pas tenus de fournir des pièces ou des produits de remplacement.

Veuillez noter que pour les articles achetés dans un magasin de détail, vous devrez contacter le détaillant pour tous les besoins en pièces.

Les produits achetés dans les vide-greniers ou les magasins à prix réduits sont vendus tels quels et ne sont pas couverts par la garantie ci-dessus.