

TRUNDLE BED

ASSEMBLY INSTRUCTIONS

Before assembling your Trundle bed, please read through these instructions carefully. Familiarize yourself with the different parts.

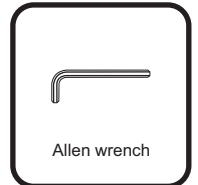
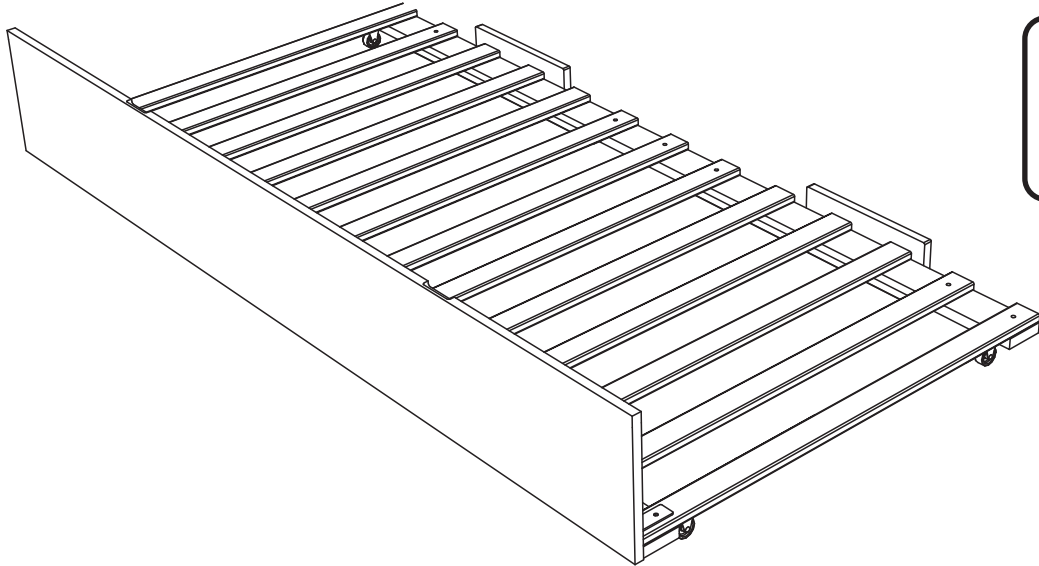

HARDWARE

NOTE: WE INCLUDE SPARE HARDWARE IN CASE DAMAGE OCCURS DURING ASSEMBLY.

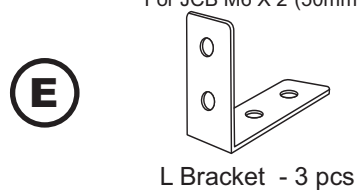
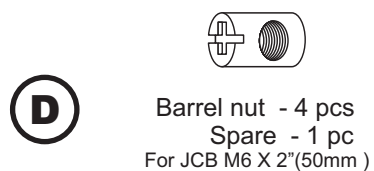
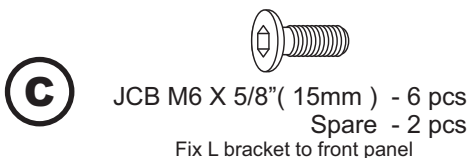
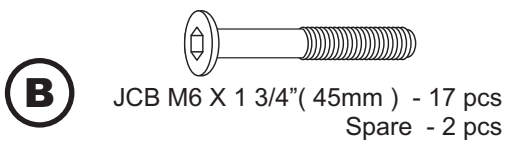
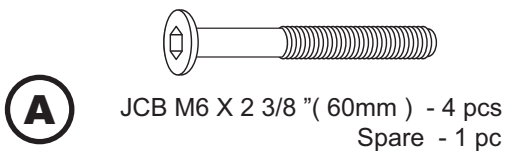

TRUNDLE BED

PARTS LIST

01	HARDWARE	1 BOX	05	SIDE CROSS RAIL	2 PCS
02	FRONT PANEL	1 PC	06	CENTER CROSS RAIL	1 PC
03	FRONT RAIL	1 PC	07	REAR BLOCK	2 PCS
04	BACK RAIL	1 PC	08	SLAT KIT	2 SET

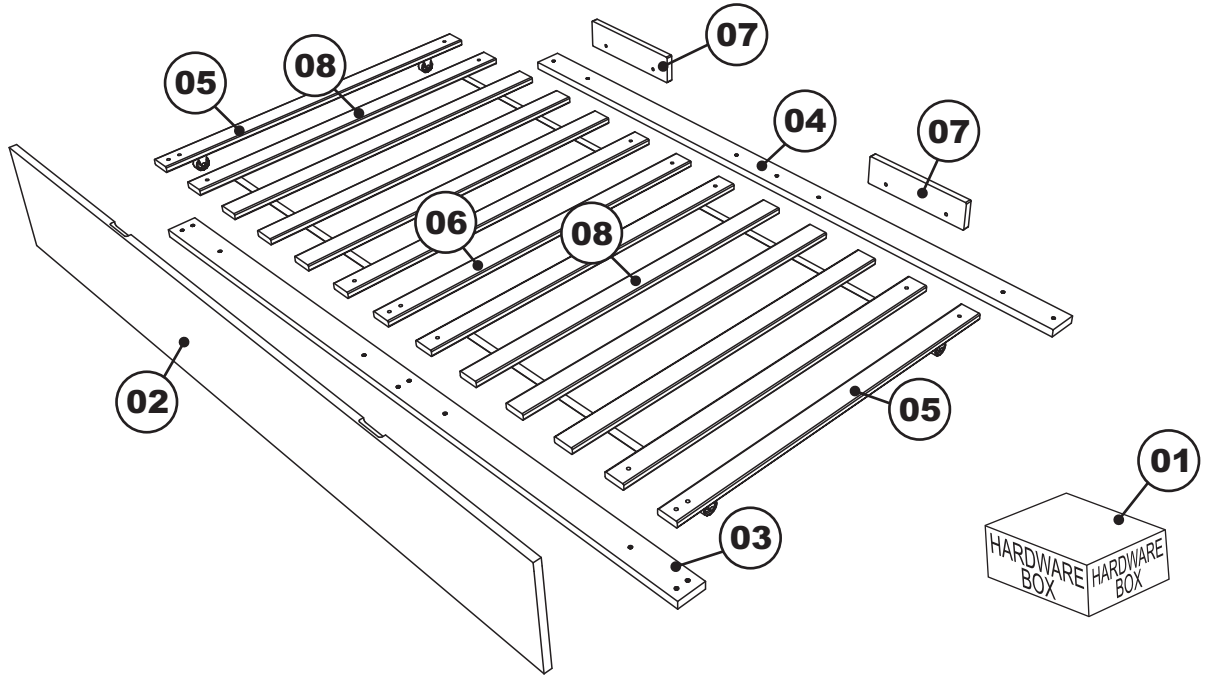

Step 1

Attach the side cross rails (05) and center cross rail (06) to the front and back rail (03)(04), using L bracket (E), JCB M6 X 1 3/4"(B). Tighten with the Allen wrench (F).

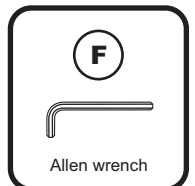
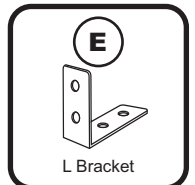
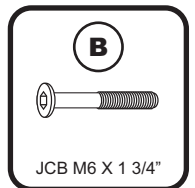
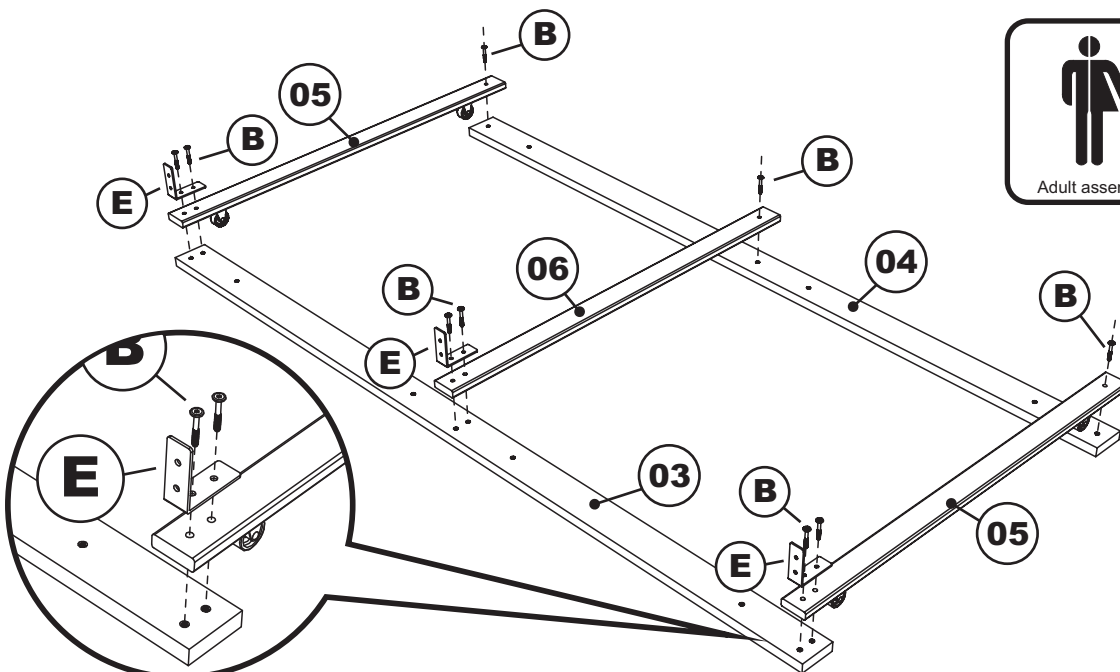

TRUNDLE BED

Step 2

Attach the front panel (02) to the front rail as shown, using JCB M6 X 5/8" (C). Tighten with the Allen wrench (F).

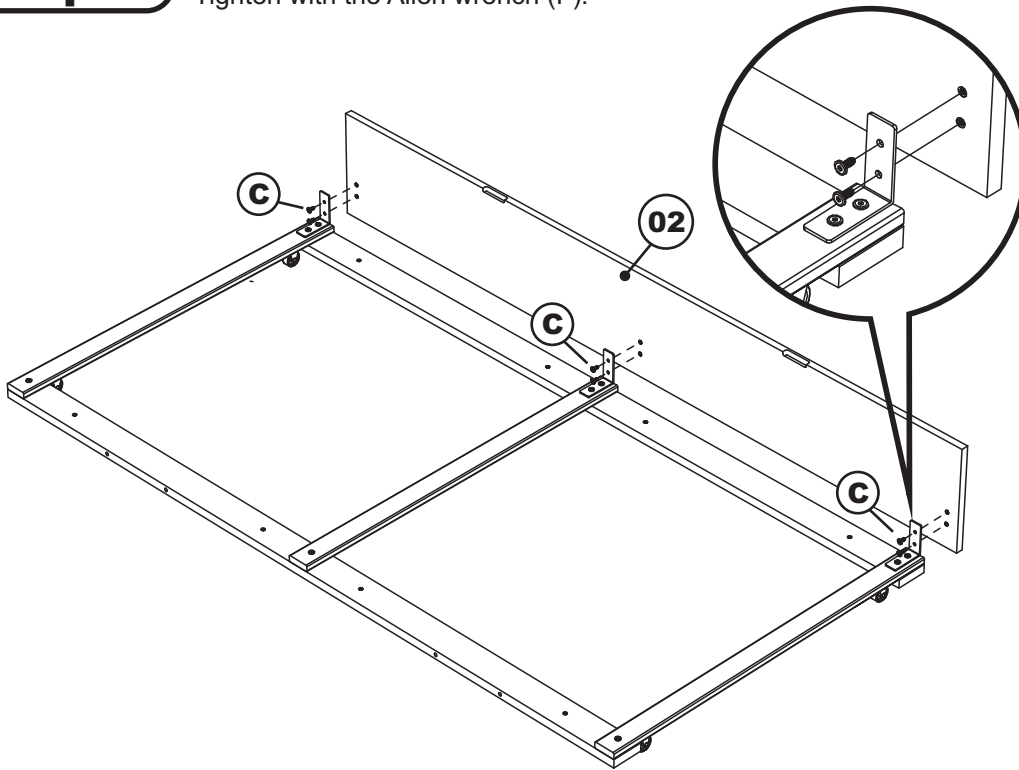

Adult assembly

C



JCB M6 X 5/8"

F



Allen wrench

Step 3

Lay the slat kit (08) onto the rail assembly as shown, using JCB M6 X 1 3/4" (B). Tighten with the Allen wrench (F).

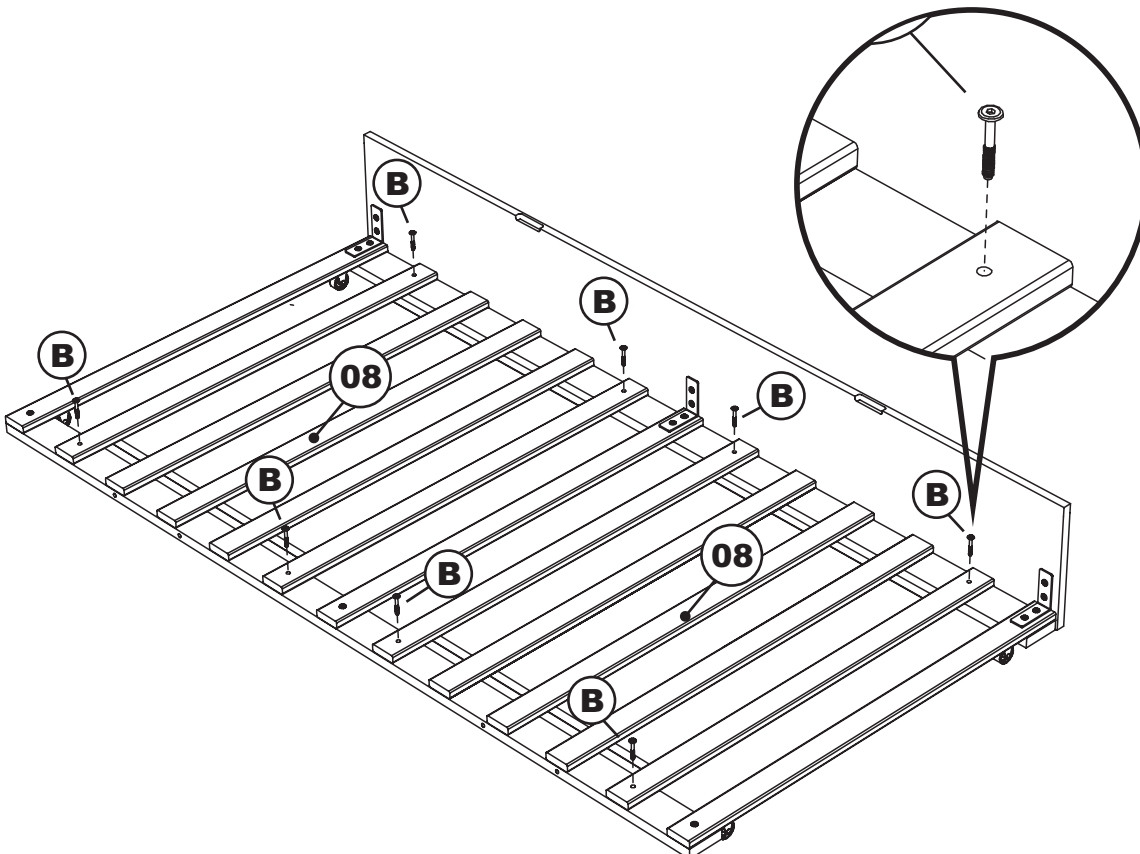

Adult assembly

B



JCB M6 X 1 3/4"

F



Allen wrench

TRUNDLE BED

Step 4

Attach the rear block (07) to the back rail as shown. Using JCB M6 X 2 3/8" (A) barrel nut (D), tighten with the Allen wrench (F)

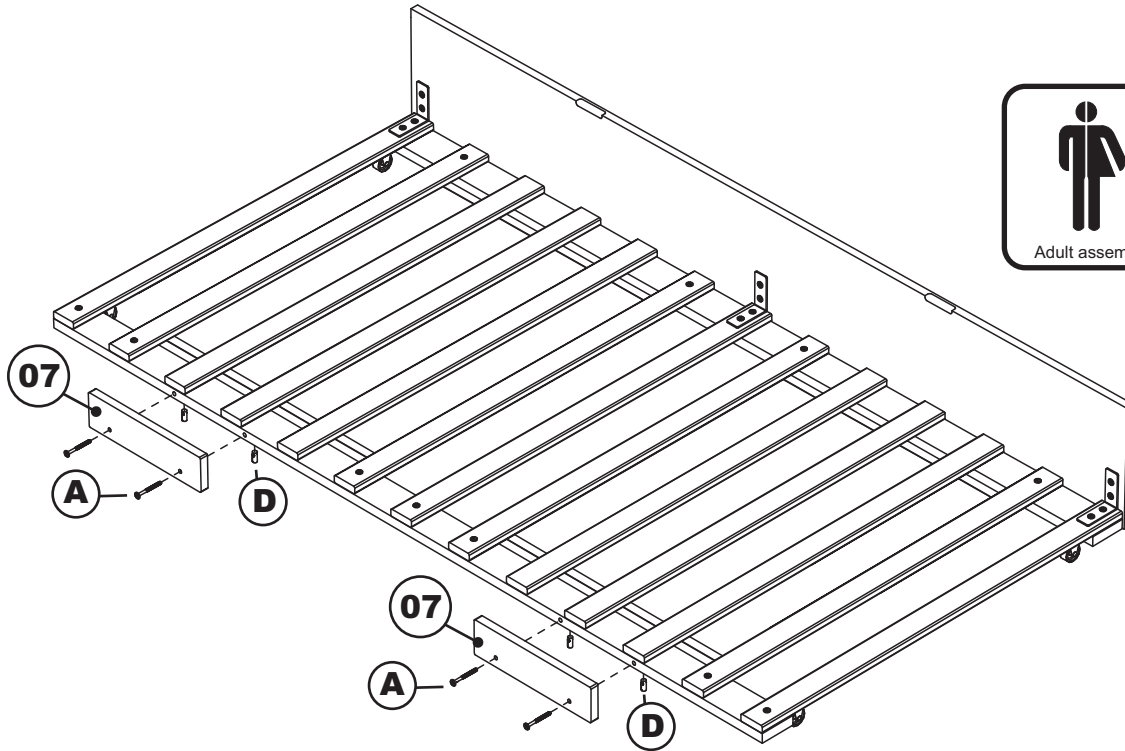

Adult assembly

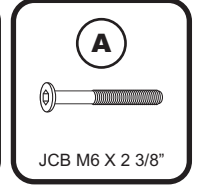

JCB M6 X 2 3/8"

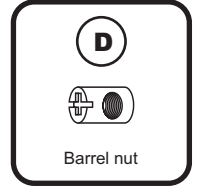

Barrel nut

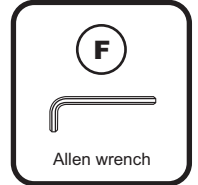

Allen wrench

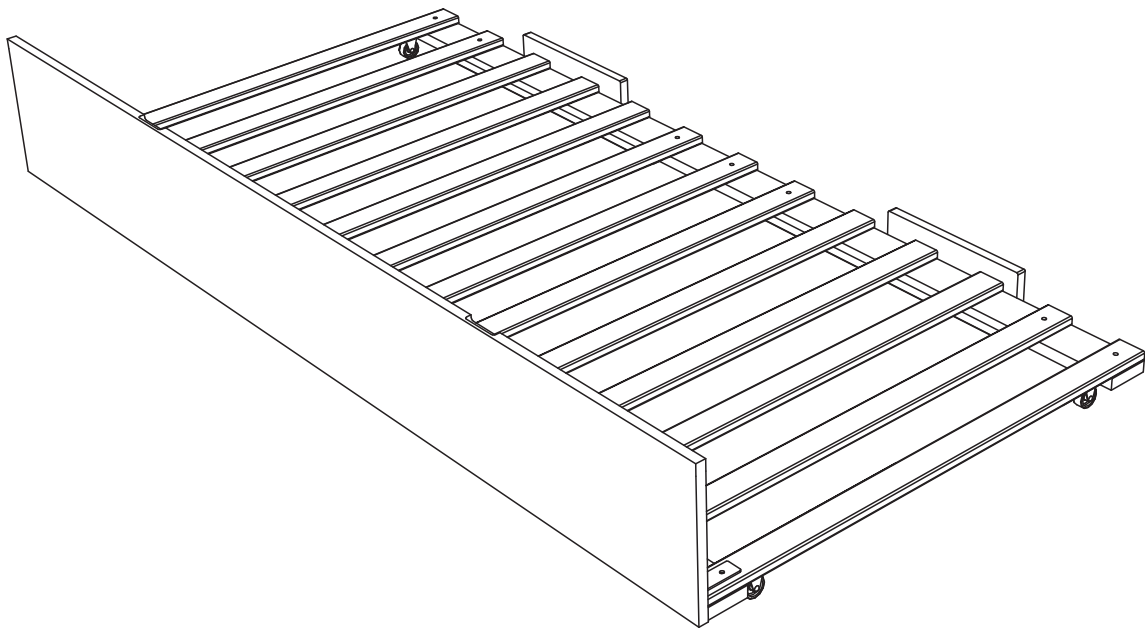

Congratulations!

Your Trundle bed is now ready for use.

We recommend that you periodically check that all screws are tight and all parts are secure to ensure lasting safety.