

ASSEMBLY INSTRUCTION

Important note:

1. Place all wooden parts on a clean and smooth surface such as a rug or carpet to avoid scratching the parts.
2. Kindly follow the assembly instructions step by step.
3. Do not tighten all screws and bolts until the table is fully assembled.
4. Unscrew the protective plastique supports from the metal insert of the table legs before assembly.

PARTS IDENTIFICATION

A Table Top

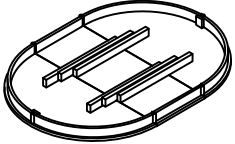

1pc

B Mounting Plate

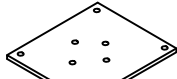

1pc

C Pedestal

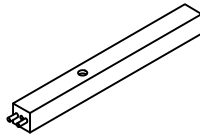

4pcs

D Table Base

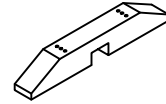

1pc

E Table Base

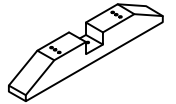

1pc

F stretcher

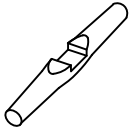

2pcs

HARDWARE IDENTIFICATION

1 Long Bolt

Ø5/16"x75mm



5pcs

2 Bolt

Ø5/16"x50mm



8pcs

3 Spring Washer

Ø5/16"x11mm



13pcs

4 Flat Washer

Ø5/16"x19mm



13pcs

5 Allen Key

M4

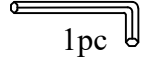

1pc

STEP 1

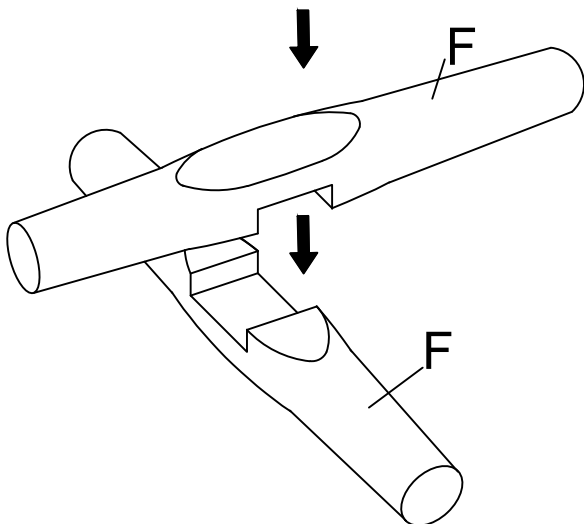

STEP 2

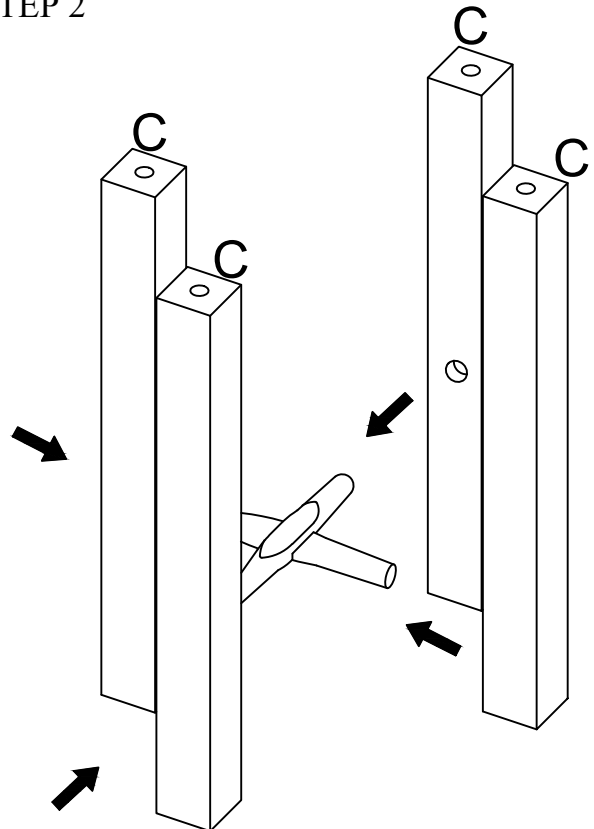

ASSEMBLY INSTRUCTION

STEP 3

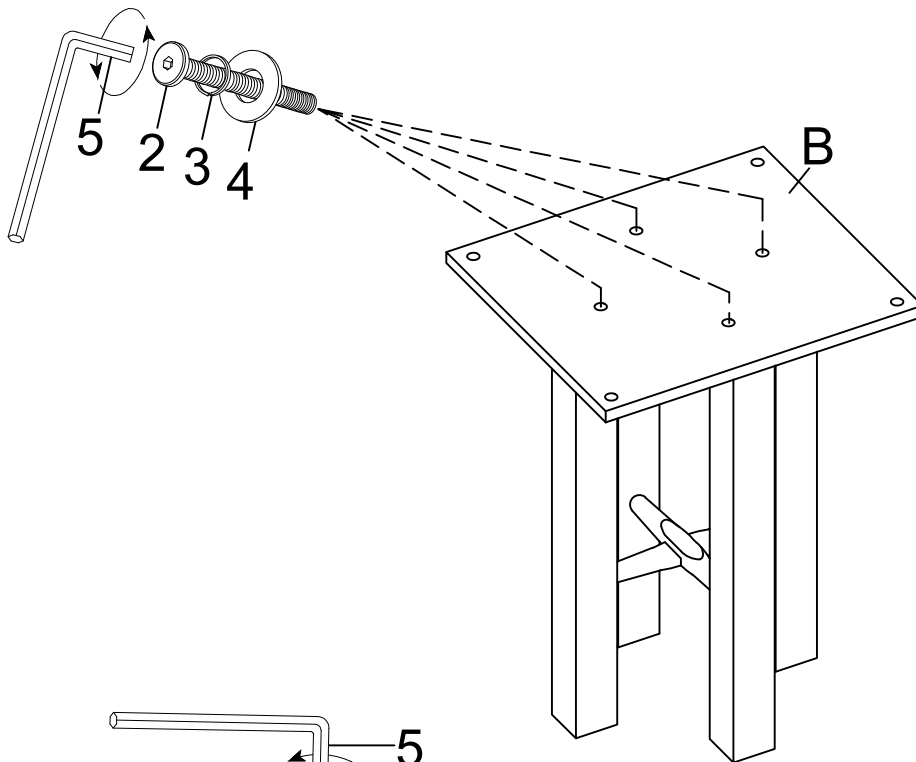

STEP 4

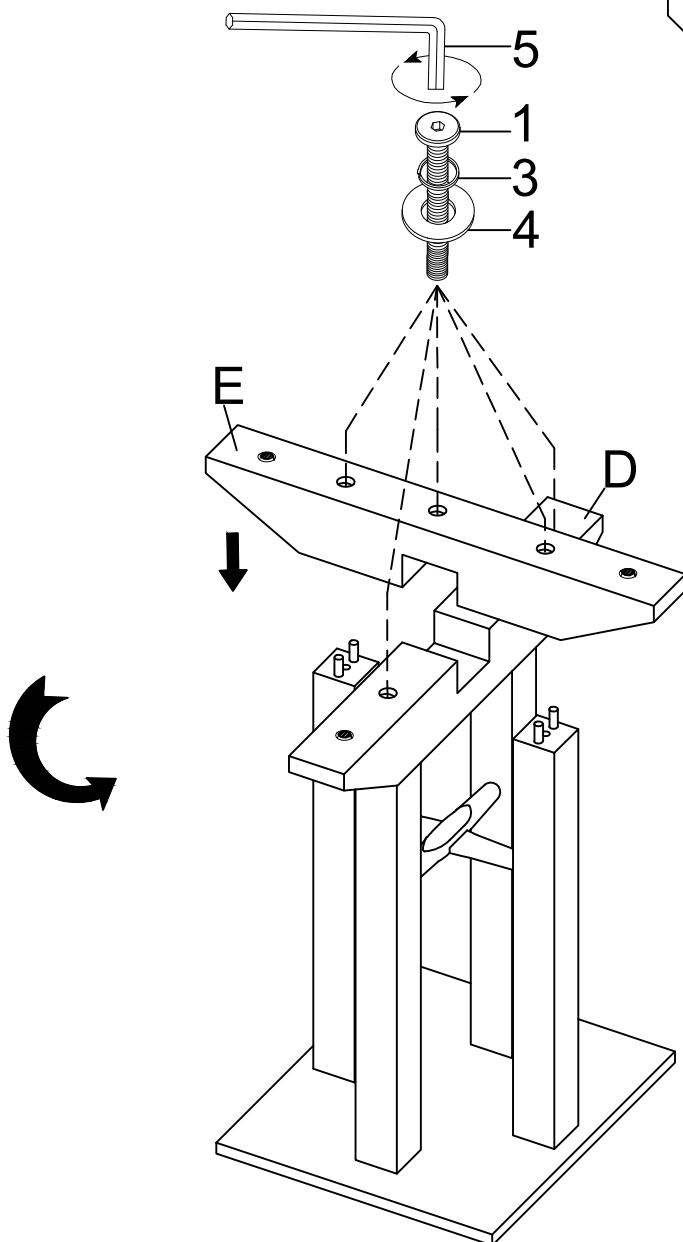

ASSEMBLY INSTRUCTION

STEP 5

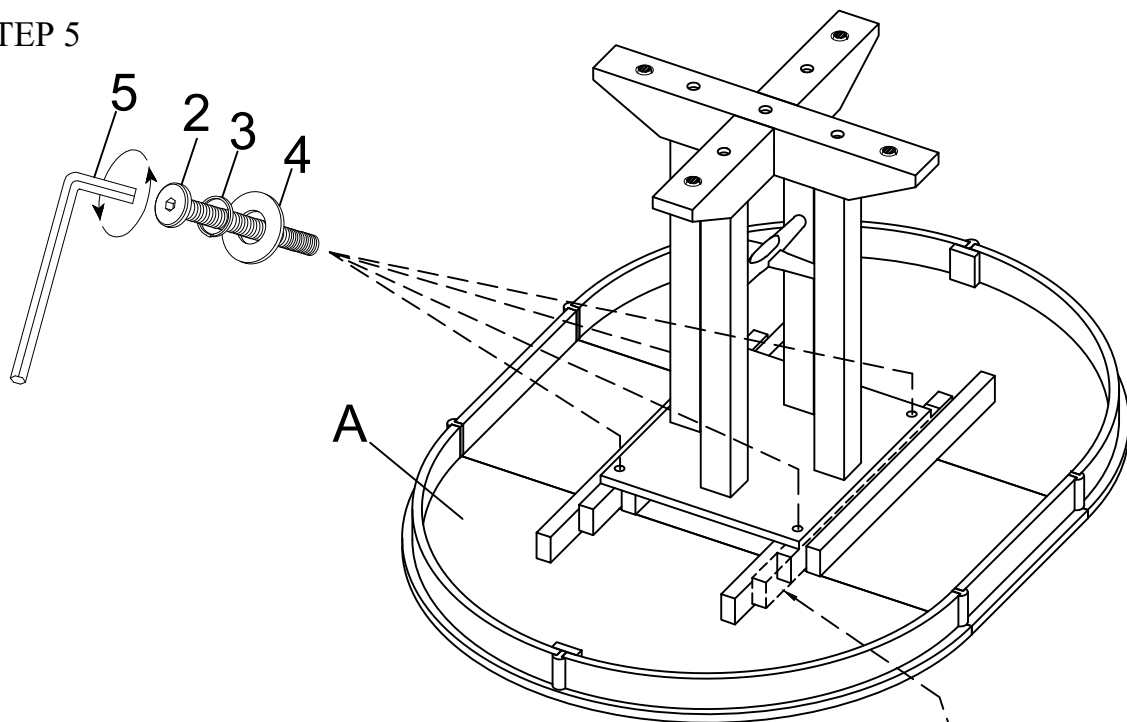

This part of the slide rail can be moved, if the holes are not aligned during the assembly process, please try to move the slide rail to the position shown in the figure and then assemble !

STEP 6

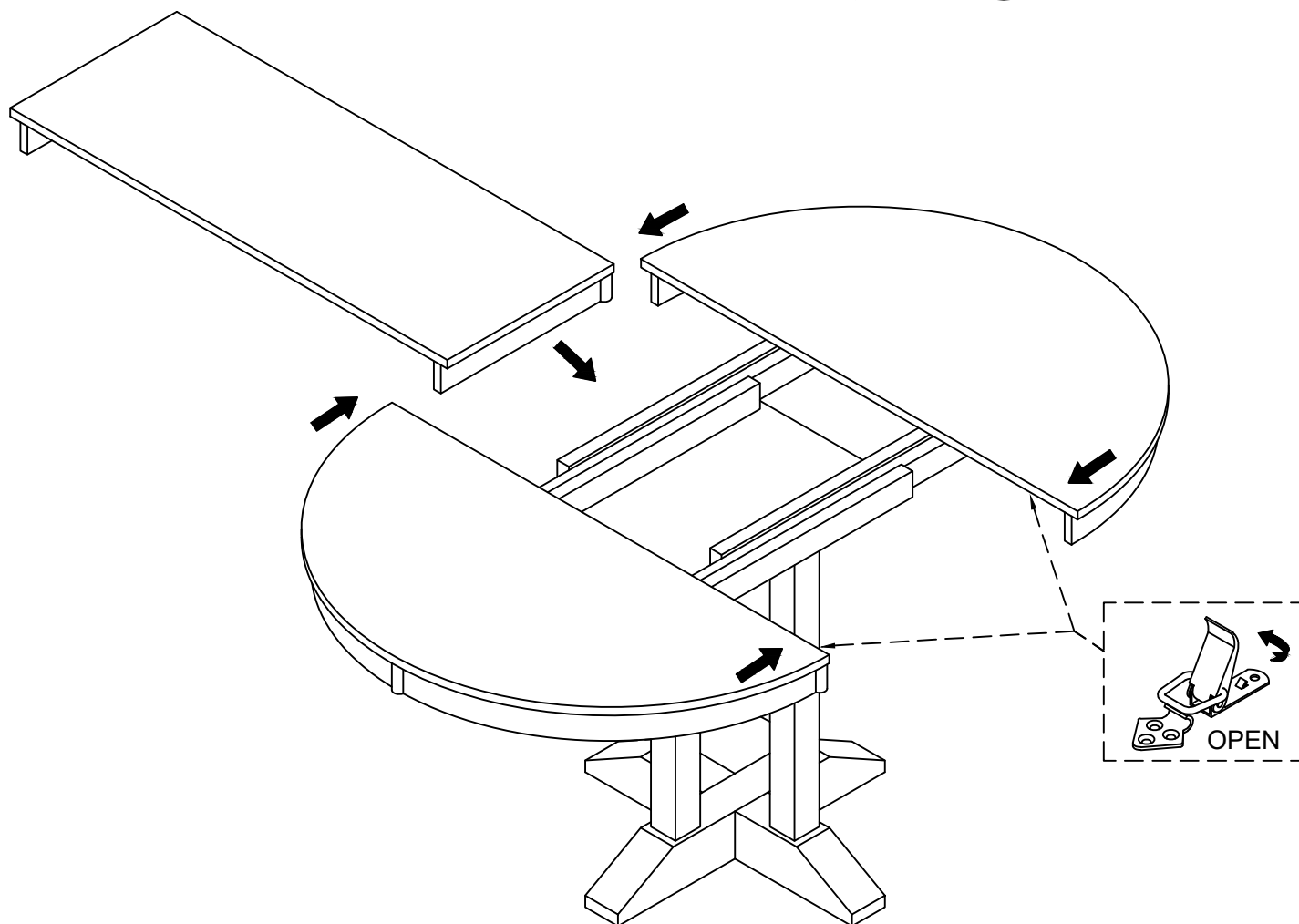

ASSEMBLY INSTRUCTION

COMPLETE

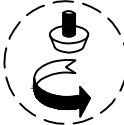
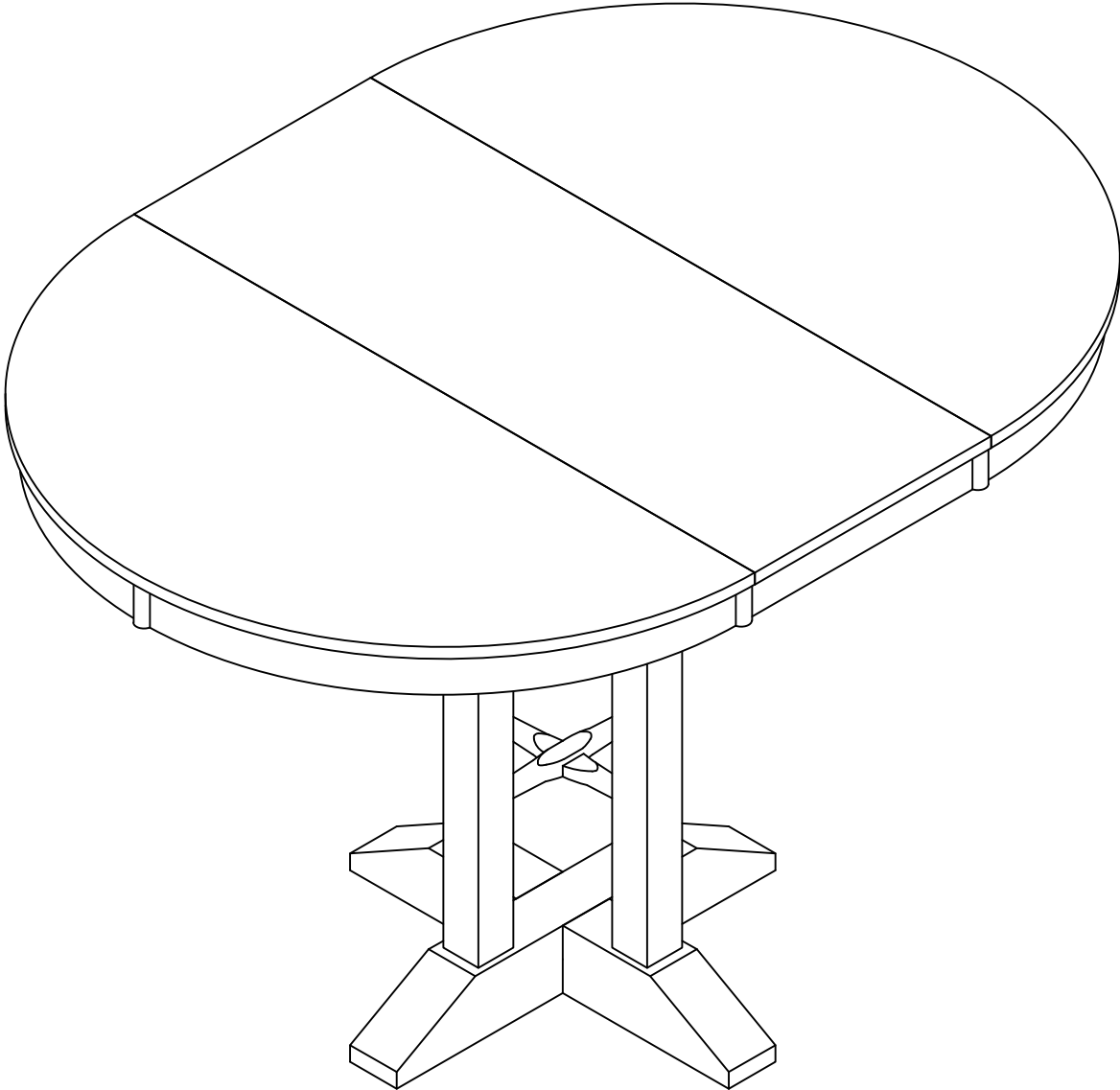

Adjust Leveler=4pcs.