



# RANGE ROVER HSE

**AGES 3+**

Item: DK-RR999  
Age Range: 37-95 Month  
Maximum Weight: 50KGS/110LBS  
Execution Standard:  
GB6675&GB19865   
EN71&EN62115



Pictures are for reference only, please adhere to the original products as standard



Land Rover and the Land Rover Logo are trademarks owned and Licensed by Jaguar Land Rover Limited.

All spare parts When open the carton



Assembling Procedure **Must be assembled by Adults**

### 1. Install under board

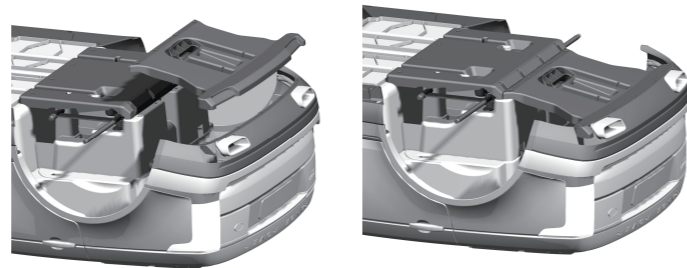

Overturn the car body, and disassemble the board. Take out the empennage and then assemble the board again.

### 2. Install motors and wheels.



Please find driving motors first and disconnect them, and then insert motors into the back axle, making the connector lines insert into the hole and connecting to the power line. (Referring to the photo).

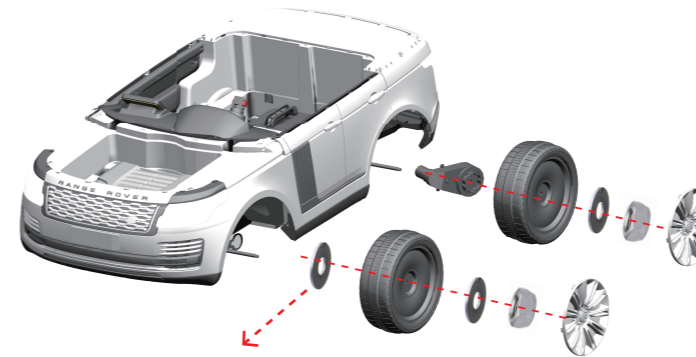

When the model is have no front motors

Please take out the bearings from the screws bag and install on the outside of the wheels. Assemble the wheels onto the front and back axles, and assemble gasket, non-slip nuts in sequence and then fix the wheel hub. (Referring to the photo)

### 3. Install steering wheel

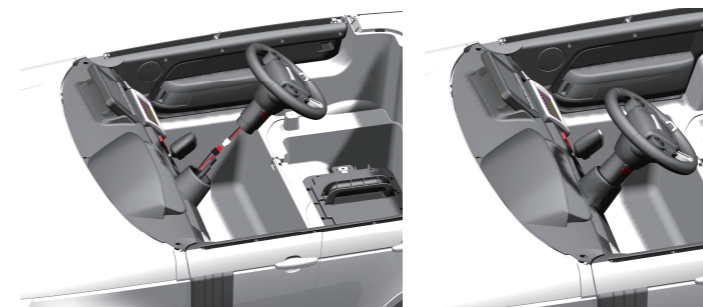

Connect the power cord and then assemble the steering wheel. (Plug the long part of the line into the steering wheel)

### 4. Install front windshield and back empennage by screws (M4\*12 flat head screw)

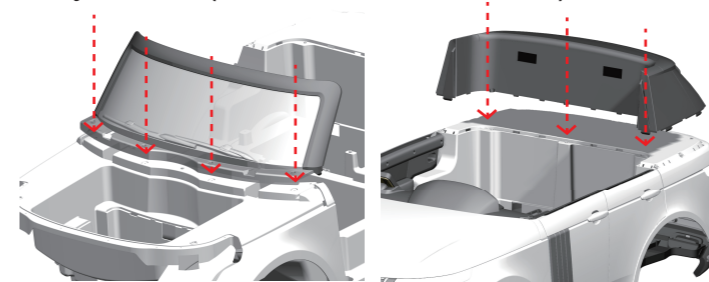

### 5. Install decoration parts and hood

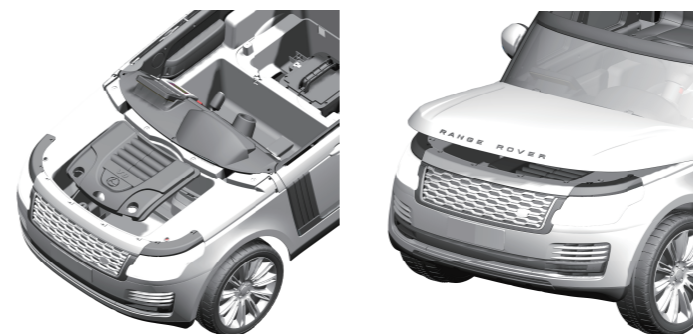

### 6. Install decoration part on car door window by screws ((M4\*12 and M4\*14 round head screw) and rear view mirrors

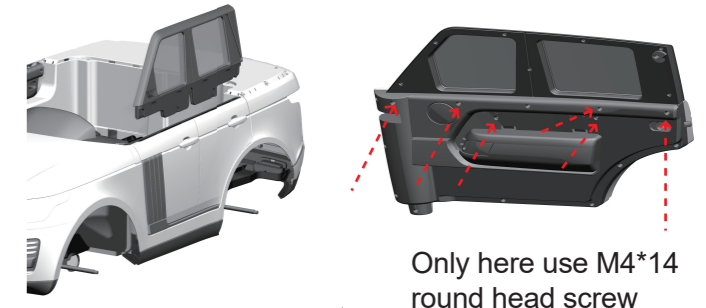

Only here use M4\*14 round head screw

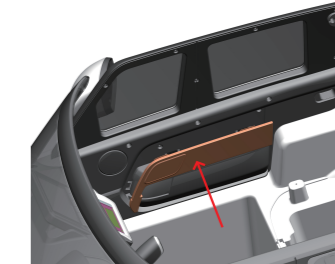

After using the screw to fix the window, install the decoration parts then.

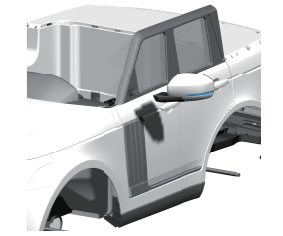

Please take a note that rear view mirrors have differences from left and right. Please insert the rear view mirrors into the window. (Refer to photo)

### 7. Power connection

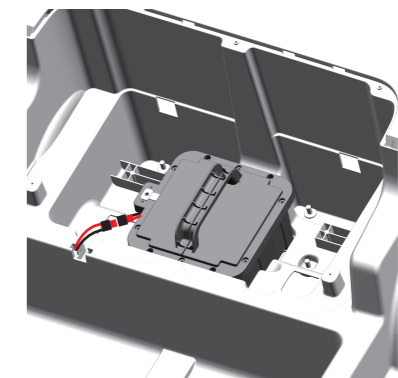

Connect power referring to the photo.

### 8. Install seat

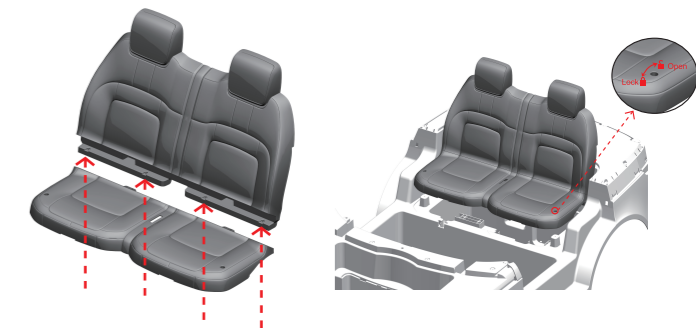

Firstly, use the four screws to fix the seat. Secondly, assemble the seat on the car. Pay attention to the snap joint back of the seat. Make them into the car body. Install the seat and make faster into the seat, and rotate the 90° to lock well.

## Specifications

Item	Specifications
Battery&Motor	12V10AH+2*35WMotors/2*12V7AH+4*35WMotors 24V7AH+2*240W Motors
Available Ages	Children from 37-95 month
Maximum Weight	50KGS/110LBS
Size	147*94*68cm / 57.9*37*26.8 INCH
Speed	3-5km/h/1.86-3.1MPH (For 12V) 6-8km/h/3.72-4.96MPH (For 24V)
Remote Control Batteries	2PCS of AAA Batteries
Charger	Input:220V/110V Output:DC12v1000MA/DC 24v1000MA

## CHARGING PRECAUTIONS

Battery polarity cannot be reversed, please ensure the red wire is connected to the red battery terminal and the black wire is connected to the black battery terminal

- Press the power switch to OFF position to turn the power off.
- Open the seat.connect the battery plugged to red.
- Never drain battery completely or to a crawling speed .recharge the battery when a decrease in speed and power is noticed. Warrantywill be voided if misuse has occurred.
- Battery charging must be done by adults only.Never allow children to charge the battery.A child could be injured by the electricity involved in charging the battery.
- Please don't connect the wires to a short circuit.The charger and the battery are not a toy.Do not allow children to play with the charger and the battery.Only operate the battery and charger specified according to the manual instructions.
- Please do not open the battery and the charger.
- To maintain safety of vehicle, always secure the battery with the bracket.
- The battery must be handled and operated by adults only: the battery is heavy and contains sulfuric acid(electrolyte). Dropping the battery could result in serious injury
- Before charging the battery check for wear or damage to the battery,charger, the connectors and other parts .If any damage found , the charger should be repaired or replaced immediately .Do not use a damaged charger.
- It is normal for the adaptor to feel warm during charging, but if the charger feels too hot, stop charging immediately and check the battery and adaptor. When charging please turn off the power switch. Please charge the battery for 8-10 hours after first use. Subsequent charges should be 6-8 hours but not exceeding 10 hours. If do not use the car for a long time, please charge at least once a month to keep the battery cells active.

- 1.Plug the charger into the charging socket.
  - 2.Plug the other end of the charger into your wall socket.
- Batteries are perishable items that are subject to under and over charging. Please observe the charging time.

## TROUBLESHOOTING

Problem: The car will not move

Answer 1: The battery is low, please charge for 6-8 hours but not exceeding 10 hours.  
Charge at least once a month to keep the battery cells active.  
Answer 2: The battery is low. Please charge the battery for 6-8 hours but not exceeding 10 hours.  
Charge at least once a month to keep battery cells active.

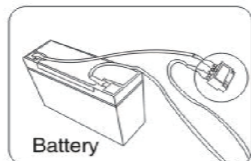

To avoid short fuse or power cut off:

1. Do not overload the product. Max load is 50Kg.
2. Do not drag any item behind this product.
3. Do not allow water or any liquid into electric parts.
4. Do not change wire system without a professional.

## TROUBLESHOOTING

Problem:The car only runs for a short time

Answer 1: The battery is low, please charge for 6-8 hours but not exceeding 10 hours.  
Charge at least once a month to keep the battery cells active.  
Answer 2: The battery may need to be replaced depending on its charging history and age.

Problem: The sound does not work.

Please ensure the volume is turned up and the MP3 line is not connected. Sounds from steering wheel will not work when MP3 is plugged in.

Problem: Charger overheating

It is normal for battery and charger to be slightly warm during charging. If the charger feel excessively hot, please check for a current overload or battery short circuit.

## SAFETY PRECAUTIONS

1. While driving , adult supervision is required all the time
2. Always wear a helmet when driving
3. Please don't drive near road or on the footpath.
4. It is not recommended to drive the vehicle on wet surface or on slope greater than 15-degree.
5. It is recommended to drive this vehicle on smooth surface only.
6. Please don't drive this vehicle outdoors when it is raining.
7. Make sure that the vehicle stop completely before changing direction from forward to reverse
8. Please don't allow children to operate the charger or play with the battery
9. Clean the vehicle with a dry cloth only.
10. Please follow the correct weight and age limits allowed to drive this vehicle.
11. It is prohibited to change the circuit or add other electric parts.
12. Adults must teach their children about safe driving procedures.
13. Please turn the power off when not in use.
14. Check the seat to ensure it has been fitted and secured with a bolt before driving.
15. Inspect all wires and connection of the vehicle periodically.
16. Charging the battery should only be done by adults.
17. Charging plug is located underneath the seat.
18. In order to avoid accidents, please ensure the vehicle is safe before driving.
19. Please don't let children touch the wheels or be near them when the car is moving.
20. Please mind fingers when opening and closing doors.

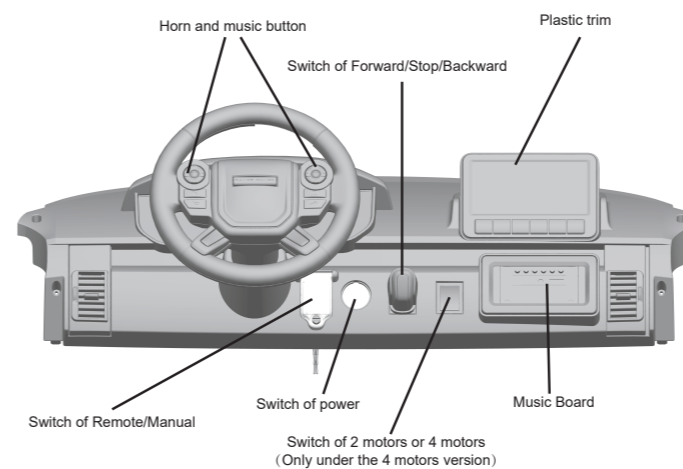

Description for the switch of Manual / Remote:  
Under the Manual : the car only can drive by the child;  
Under the Remote : the car only can drive by the remote control;

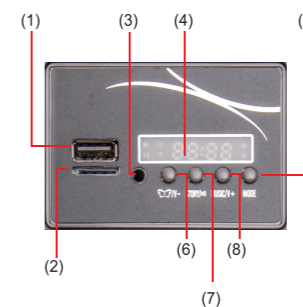

1. socket
- 2.Storage card socket
- 3.Audio input
- 4.Display
- 5.MODE choose(Radio/wireless connection/Storage card connection)
- 6.Education(Pressing for a longer time and it will lower the volume)
- 7.Story(Play/ Pause under the wireless connection/Storage card functions)
- 8.Music(Pressing for a longer time and it will higher the volume)

## "RC For 12V:"



## Operation Guide

For first time use or after replacing the battery, select not to pair. The car will power on after turning the ignition key.

If you choose to pair the remote control with the car, please follow the instructions below.

- Step1. Insert two AAA 1.5V batteries into the battery compartment of the remote control. Ensure the battery polarity is matched correctly. If the frequency lights flashes then the battery is correctly installed.
- Step 2: Hold the Car Select button for 2-3 seconds.
- Step 3: Turn on the ignition key to turn on the car.

- \*Manufactured according to FCC certification testing and ECM credential.
- \*This remote is to be used by adult only.

## RC For 24V:

For the first time need to code,this product has a memory function, repl-acement battery next time, you do not need to match the code Once again.  
①.Long press "M" button more than three seconds, until the first LED lights flashing.  
②.Open body power, first a long bright LED turns on the success of the code.  
③.Remote control 10 seconds without operating automatic standby, pressany key to wake up.  
④.Key Description: "△" Forward, "▽" Back, "◀" Left, "▶" Right, "S" Speed, "P" Stop.  
Press the "S" key to set the speed, a light is low, two lights for medium-speed, three lights for high-speed, the car back with only medium-speed  
Press the "P" key to keep the brakes, the indicator full flash, press the brake button again to lift the brake.

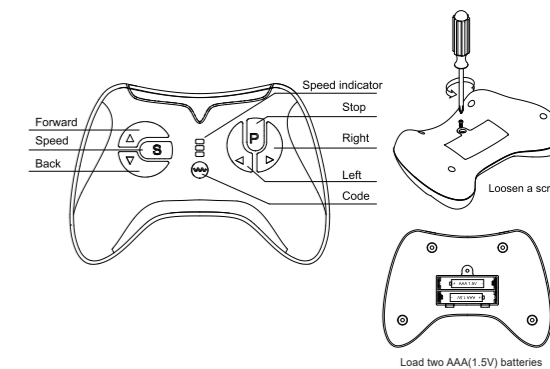

- WARNING!** Not for children under 3 years. Small parts. Choking hazard  
-Load two AAA ( 1.5V ) batteries according to the diagram.  
-Non-rechargeable batteries are not to be recharged.  
-Different types of batteries or new and used batteries are not to be mixed.  
-Batteries are to be inserted with the correct polarity.  
-Exhausted batteries are to be removed from the toy.  
-The supply terminals are not to be short-circuited.  
-The packaging must be retained since it contains important information.

**Warning-When replacing a replaceable battery,first open the lid and take out the old battery.Put in the new battery,pay attention to the positive and negative poles,cover the lid.**

**! WARNING!**

For safety reasons,  
\*please use this vehicle under adult guidance and supervision.  
\*do not use this product on main roads, slopes, highways or other dangerous places.  
\*children must wear shoes and protective gears when operating the vehicle.  
\*children should be seated with the seat belt fasten when driving.  
\*only load a maximum of 50Kg on the vehicle.  
\*only children aged 37 - 95 months should be allowed on this vehicle.  
\*use this toy strictly according to safety manual.  
\*please check the tires, breaks, steering wheels, seats and seat belts before operating vehicle.  
\*this toy vehicle should be used with caution and requires skill to avoid fall or collision with third parties.

**Pictures are for reference only, please adhere to the original products as standard**

**WARNING: To reduce the risk of injury, adult supervision is required.**  
**Never use in roadways, near motor vehicles, on or near steep inclines or steps, swimming pools or other bodies of water; always wear shoes, and never allow more than 2 riders.**