

THANK YOU SO MUCH FOR PURCHASING OUR PRODUCT. IF YOU HAVE ANY TROUBLE PUTTING YOUR KIT TOGETHER OR MISSING PIECES PLEASE CONTACT US.

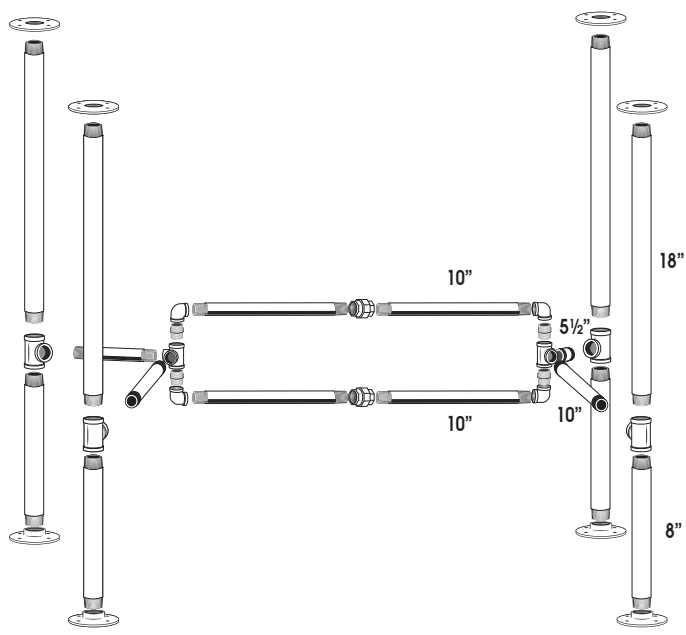

This kit is made of industrial grade authentic pipe. It is coated in oil post production to prevent rust. The kit should be cleaned and sealed to prevent rusting. See Clean and Seal sheet for more information on cleaning and sealing your pipe kit.

1. Assemble Each leg with a 2 X FLANGE (A) 1 X 8" PIPE (B), 1 X TEE(C), 18" PIPE (D), as shown in Box 1. Repeat with other legs
2. Connect legs with a 5.5" PIPE(F) in the back and 10" PIPE(E) in the front. 1X SIDE OUT TEE, 2 X CONNECTORS, and 2 X ELBOWS as shown in box 2. Repeat with other side.
3. Connect sides with each other using 4 X 10" PIPE and 2 X UNIONS. Screw each 10" PIPE as tight as you can by hand into the union. Attach the pipe to the elbow on the union side with no text. Then loosen the union and turn the union bolt to screw PIPE into the other elbow. Tighten union. Repeat with bottom side of loop.
4. Loosen or tighten flanges to level table, and screw into table top.

Flanges may scratch floor and pads are recommended.

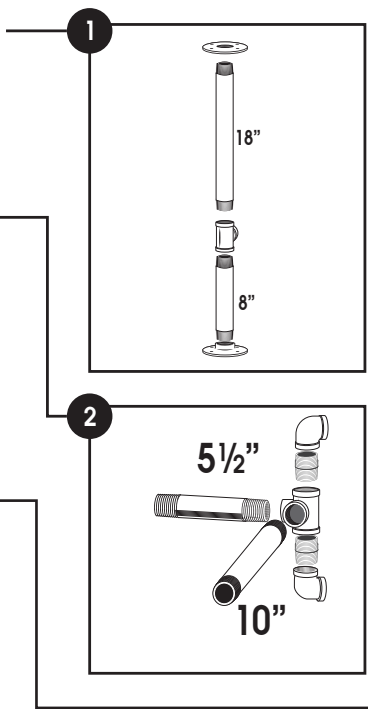

- A - 8 X FLANGES**
- F - 6 X 10" (1/2")PIPE**
- B - 4 X 8" PIPE(3/4")**
- G - 2 X SIDE OUT TEE**
- C - 4 X R TEES**
- H - 4 X CONNECTOR**
- D - 4 X 18" PIPE(3/4")**
- I - 4 X ELBOW**
- J - 2 X UNIONS**
- K - 16 X 3/4" SCREWS**

RECOMMENDED TOOLS

RECOMMENDED FOR ATTACHING LEGS TO TABLE TOP

