

# INSTRUCTION MANUAL

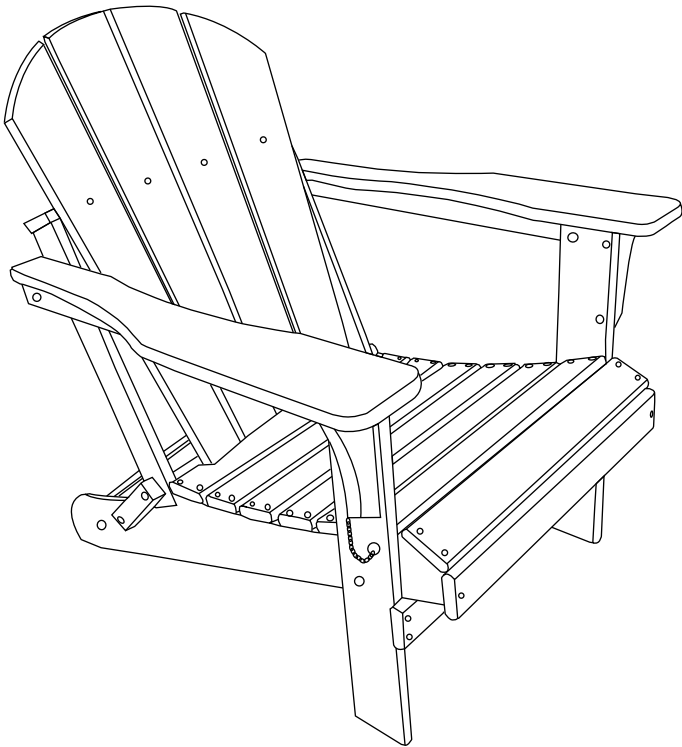

**Outdoor Folding Poly Adirondack Chair**

## ! NOTICE

### Do not overtighten screws. (Insert all screws before tighten screws.)

- Please do not exceed the weight limitations of this item.
- Do not stand on or use any part of this item as a step ladder.
- Firmly secure all bolts, screws and nuts before use.
- Reconfirm that all bolts, screws, and nuts are secure every 90 days.
- Do not use or store this item in the proximity of open flame or flammable/combustible chemicals.
- Be aware that some parts are heavy and have sharp edges.
- Be very careful when folding chair to avoid smashing your hands or fingers.

## TOOLS REQUIRED



ALLEN WRENCH  
(PROVIDED)



WRENCH  
(PROVIDED)



CHAIR  
330 LBS  
CAPACITY



1 PERSON  
ASSEMBLY



UP TO 30 MIN.  
ASSEMBLY

## HARDWARE

1

M6 x 60mm  
BOLT

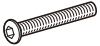

4 PCS

2

M6 x 50mm  
BOLT



6 PCS

3

M6 x 40mm  
BOLT



2 PCS

4

M6 x 30mm  
BOLT



4 PCS

5

M6 NUT



8 PCS

6

M6 WASHER



8 PCS

7

WRENCH



1 PC

8

ALLEN  
WRENCH



1 PC

## PARTS

A

CHAIR SEAT

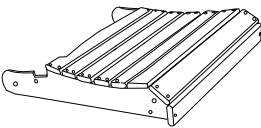

1 PC

B

RIGHT CHAIR LEG

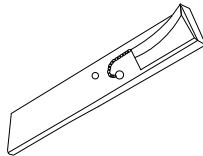

1 PC

C

LEFT CHAIR LEG

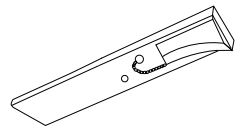

1 PC

## PARTS

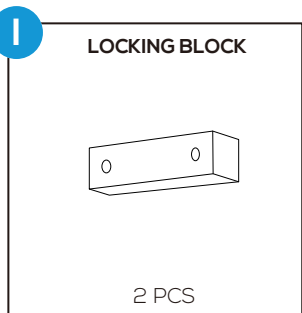
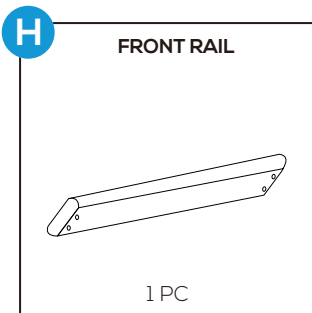
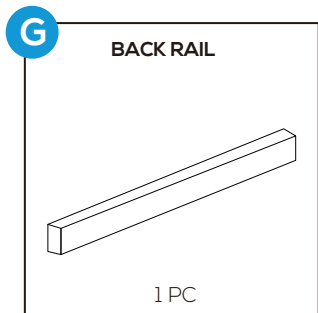
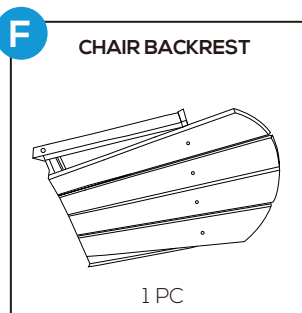
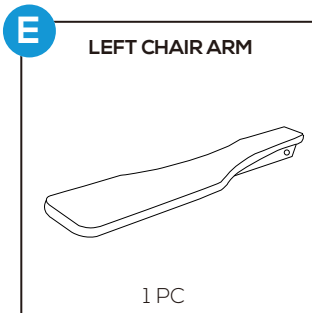
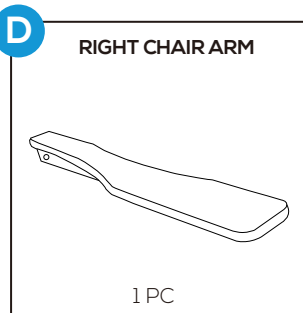

## PRODUCT ASSEMBLY - OVERALL VIEW

**1**

Look at following overall view of this chair and learn the exact position of each parts to be assembled.

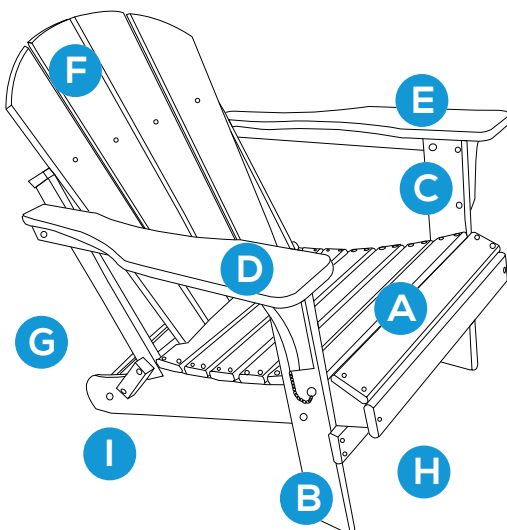

## PRODUCT ASSEMBLY

1

Attach part C Left Chair Leg to part E Left Chair Arm with 1 PC of part 1 bolt and part 6 washer and part 5 Nut. Do same to part B Right Chair Leg and part D Right Chair Arm. Attach the locking stick to Chair legs with a screw driver before assembly.

Do not tighten screws too much at this stage.

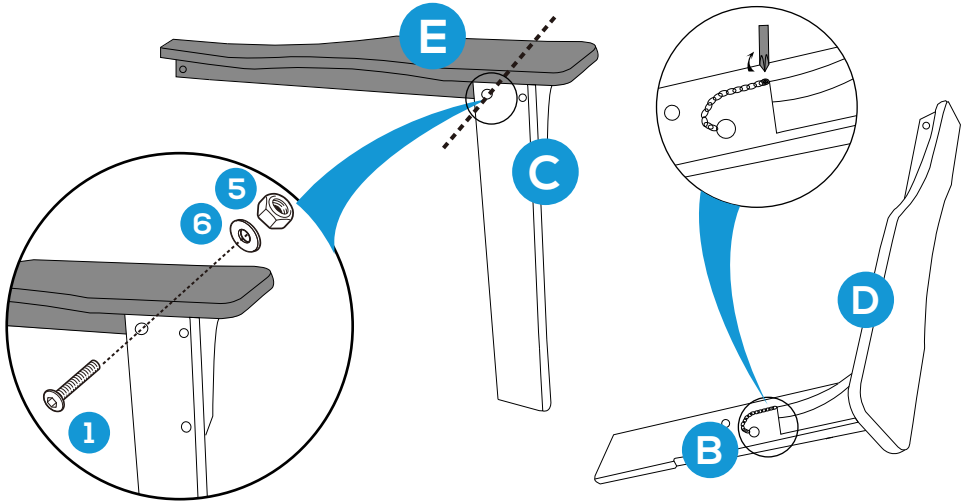

2

Attach part B right Chair Leg and part C Left Chair Leg to part A Chair Seat with 2 PCS of part 1 bolt and part 6 washer and part 5 Nut.

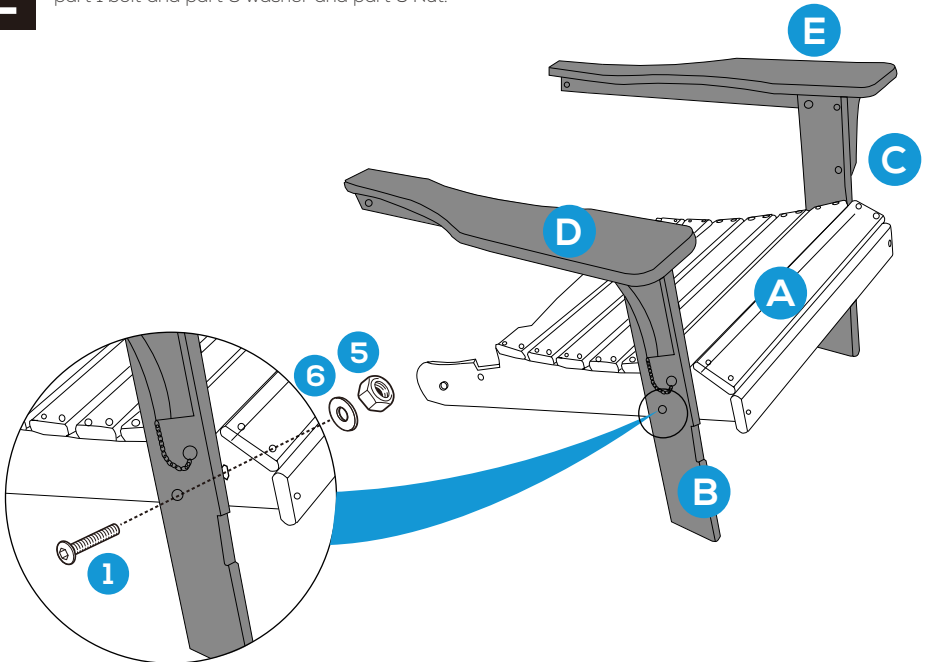

## PRODUCT ASSEMBLY

**3**

Fix part F Backrest into part A Chair Seat and then attach part F Chair Backrest to part D Right Chair Arm with 1 PC of part 2 bolt and part 6 washer and part 5 Nut.

Do the same to attach part F Backrest to part E Left Chair Leg.

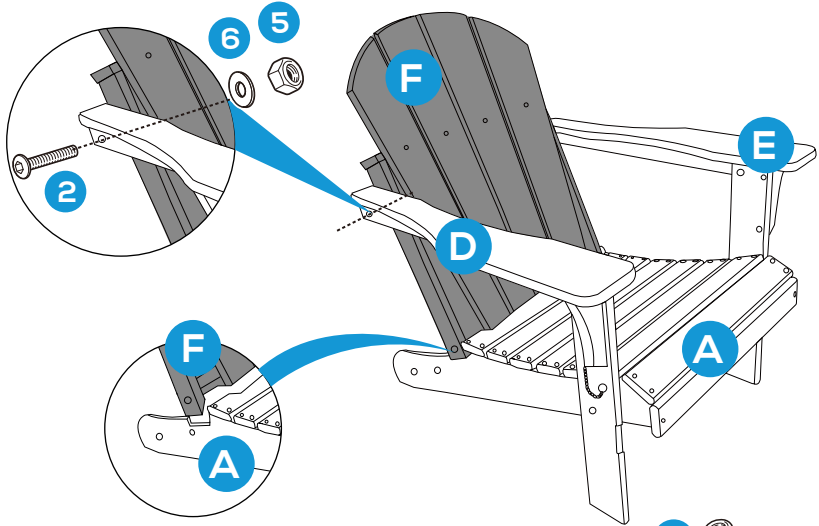

**4**

Attach part I Locking Blocks to part F Chair Backrest and part A Chair Seat (Both sides) with 4 PCS of part 2 bolt and part 6 washer and part 5 Nut.

Pay attention that washer and nut is only needed for lower hole.

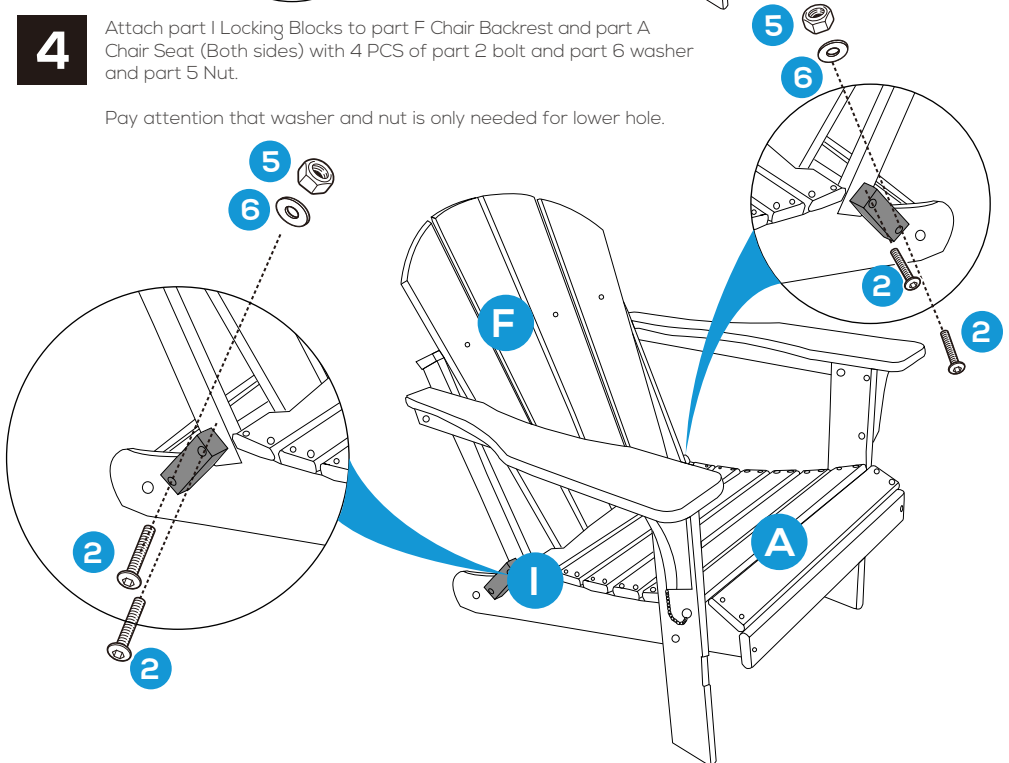

## PRODUCT ASSEMBLY

5

Attach part G Back Rail to part A Chair Seat with 2 PCS of part 3 bolt

Attach part H Front Rail to Part B Left Chair leg and part C Right Chair leg with 4 PCS of part 4 bolt.

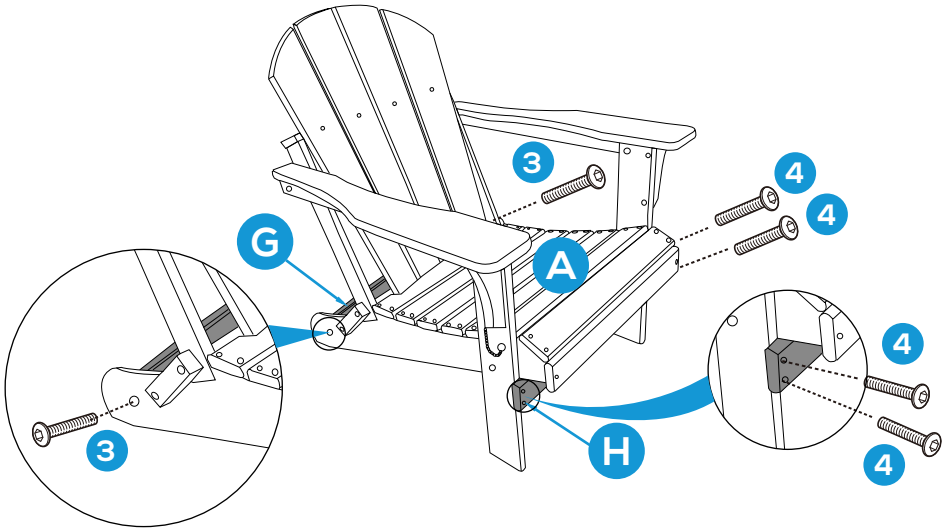

Congratulation! You finishes the assembly of this Adirondack Chair.

Pull the stick out of both legs to fold this chair as below.

