

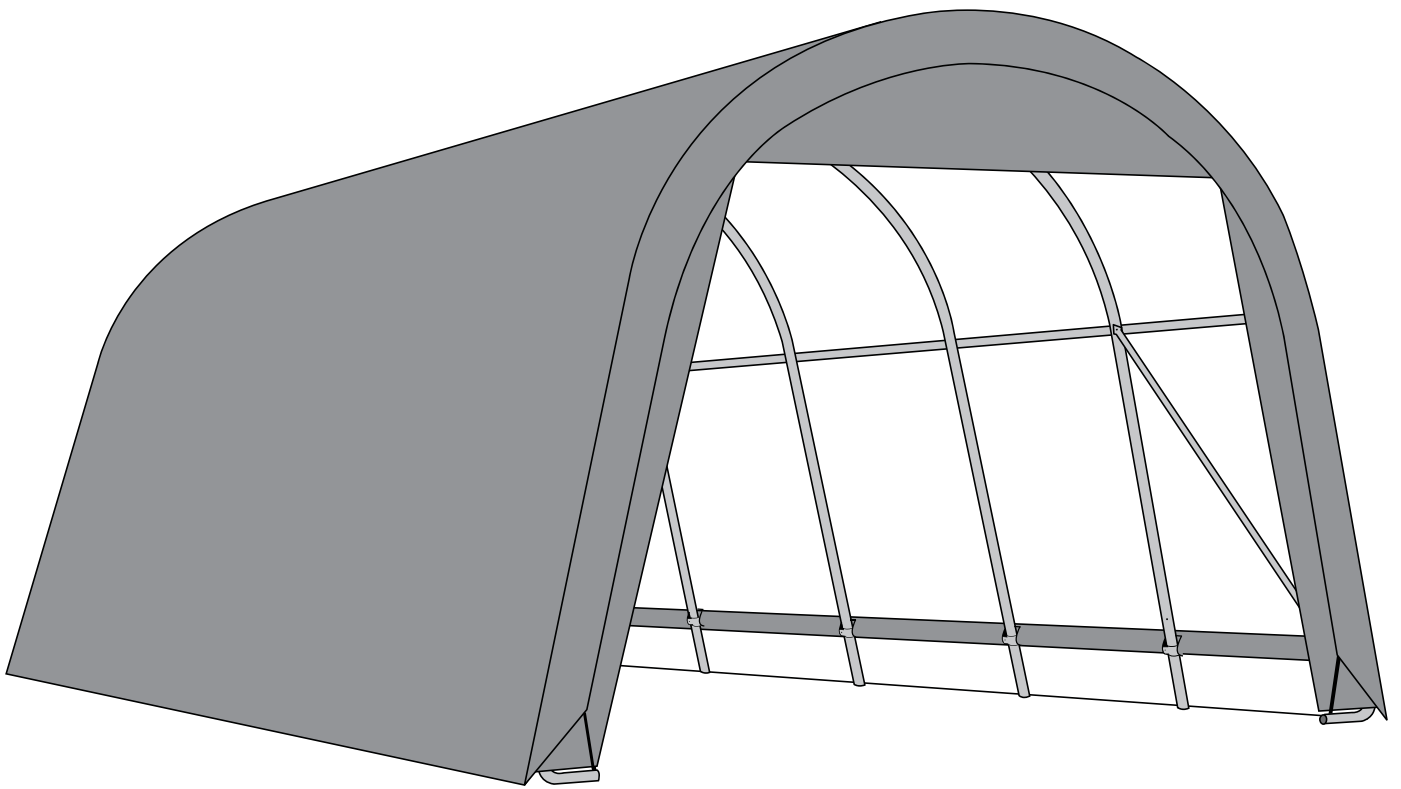

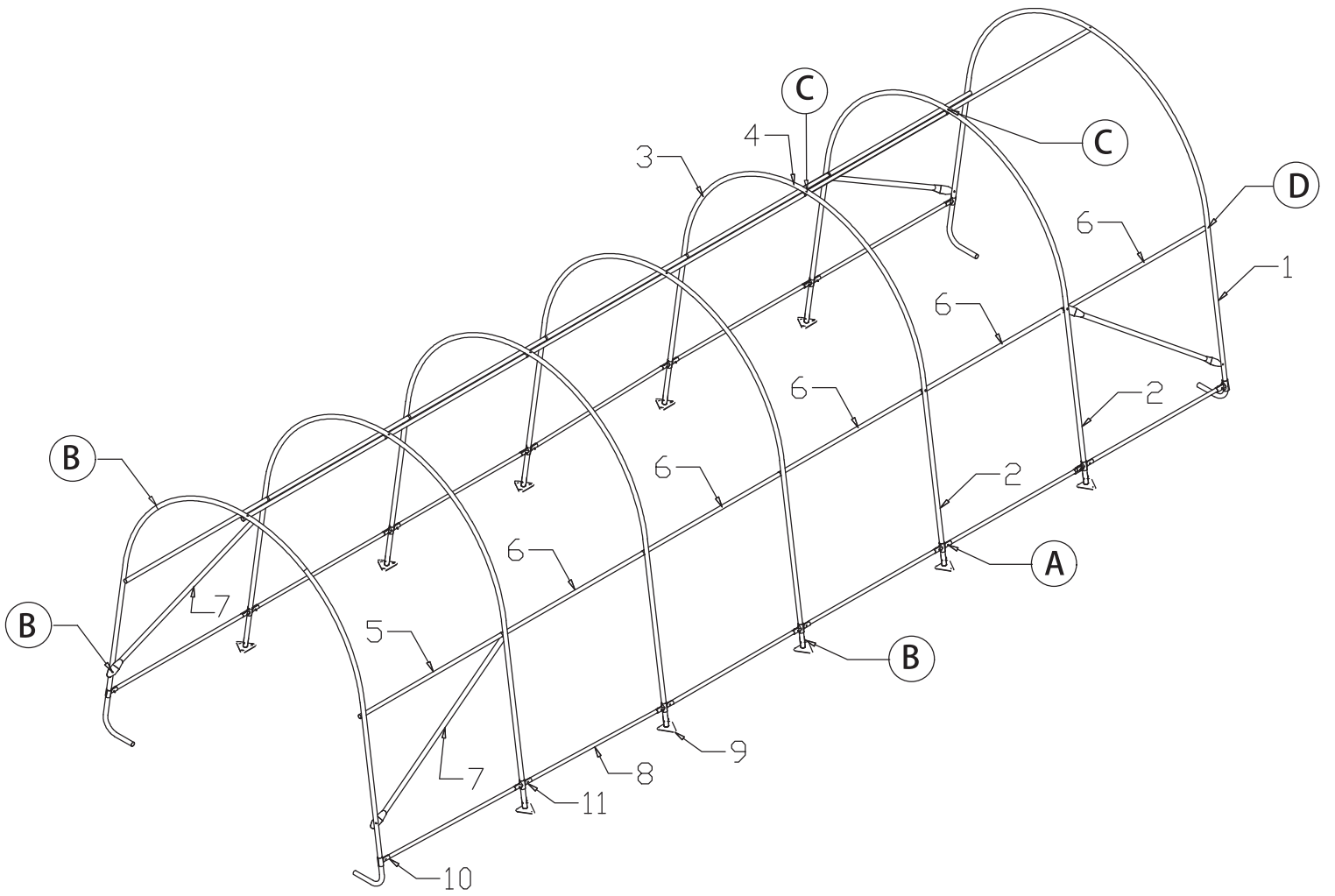







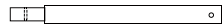

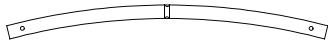
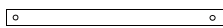
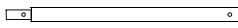
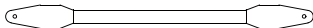
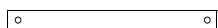

# YYCP001





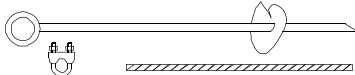
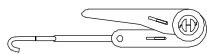

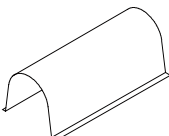

# Content

ID Nr.	Part name		
<b>1</b>	Pipe 1400mm-35mm		4
<b>2</b>	Pipe 1184mm-35mm		10
<b>3</b>	Pipe 1529mm-35mm		14
<b>4</b>	Pipe 1534mm-35mm		7
<b>5</b>	Pipe 1226mm-31.8mm		3
<b>6</b>	Pipe 1273mm-31.8mm		15
<b>7</b>	Pipe 1496mm-31.8mm		4
<b>8</b>	Pipe 1152mm-28mm		12
<b>9</b>	Foot		10
<b>10</b>	Half clamp for corner leg		8
<b>11</b>	Half clamp for middle leg		20
<b>A</b>	Screw M6*45mm		28+2
<b>B</b>	Screw M6*50mm		24+2
<b>C</b>	Screw M6*75mm		7
<b>D</b>	Screw M6*80mm		14+2
<b>E</b>	rotate anchor		30
<b>F</b>	Peg 40cm+ steelwire +clamp for 3A		4
<b>H</b>	Ratchet		4
<b>I</b>	34MM		4

# Content

ID Nr.	Part name		
	Roof		1
	Front wall with door		1
	End wall		1
	Bungees		32+4

## 1. PLOTTING THE FRAME:

Before building your shelter, you should choose a flat area on your property and plot your shelter.

**A.** Stake out the area for the shelter in the desired spot. The width of the area should be at least equal to the width of the shelter and the length should be equal to the length of the shelter **Fig. 1**.

**B.** Measure diagonally from corner to corner (A & B). These measurements should be the same. If they are not equal the stakes need to be adjusted until the width, length and inside measurements are correct.

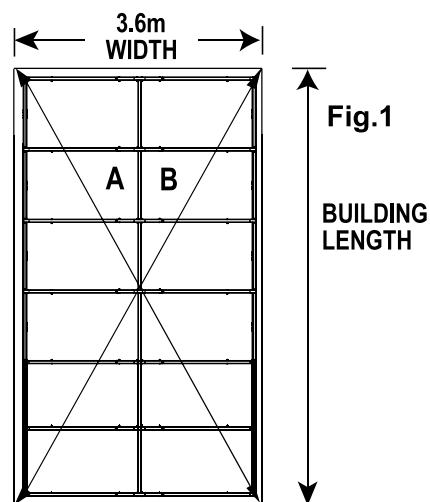

## **2. ASSEMBLE END RIBS**

Assemble end ribs as shown in **Fig. 2**. Securely fasten all of the joints with the hardware indicated.

**Fig.2**

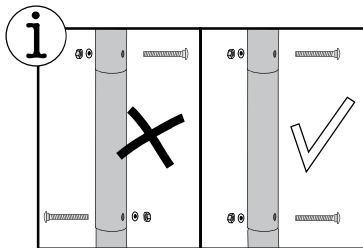
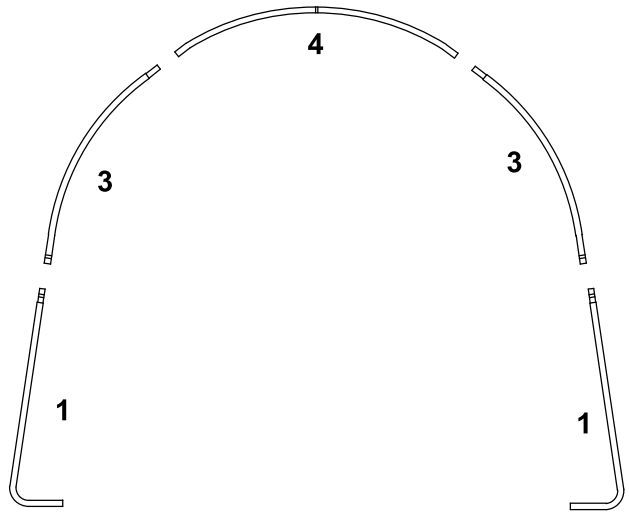

## **3. ASSEMBLE MIDDLE RIBS**

Assemble middle ribs as shown in **Fig. 3**. Securely fasten all of the joints with the hardware indicated.

**Fig.3**

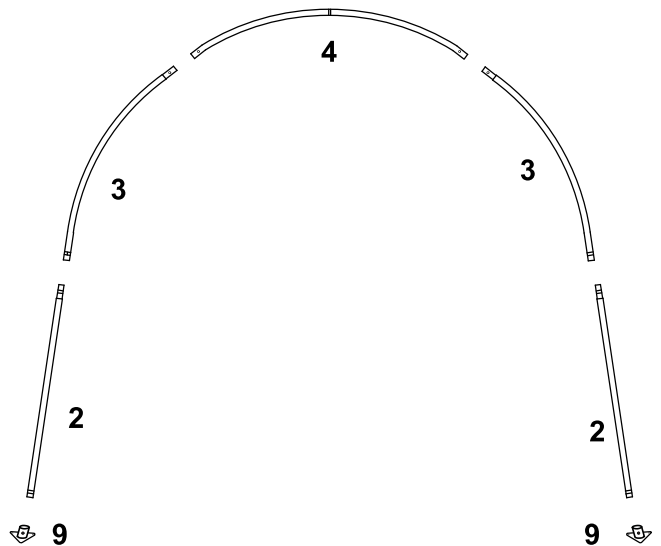

#### **4. CONNECT THE FRONT END RIB TO THE MIDDLE RIBS**

A. With help, move the front end rib into the desired staked area.

B. Place the D on the upright as shown in Fig. 4.

**Repeat steps A-B for the each of the middle ribs.**

C. Place the wind brace over the Cross Rail. Install the nut onto the bolt and tighten.

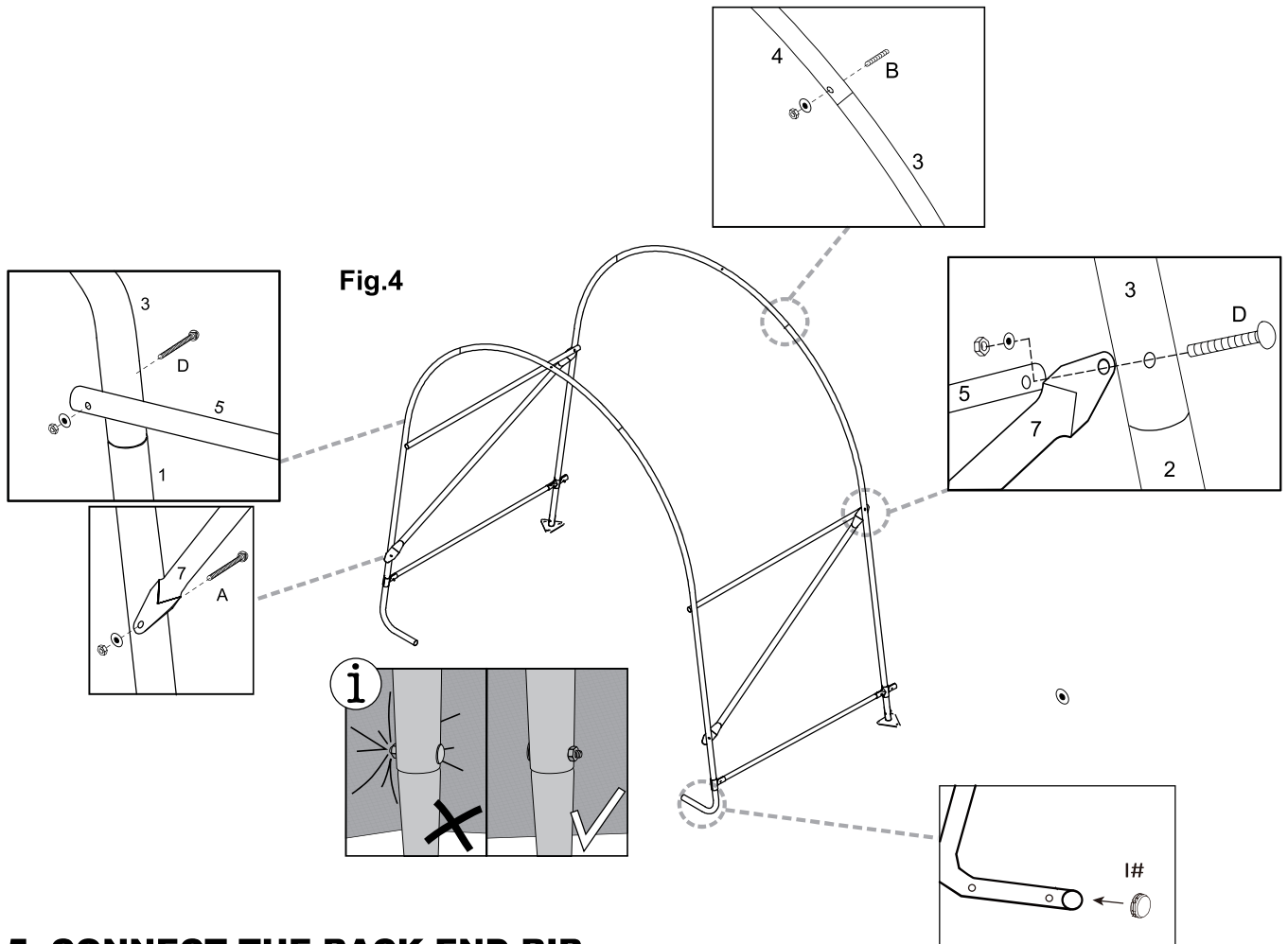

#### **5. CONNECT THE BACK END RIB**

The Cross Rails for the last rib will have two plain ends .

Take the wind brace and attach it between the end rib and the last middle rib as shown in Fig. 6.

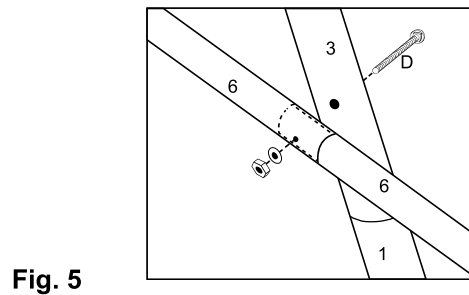
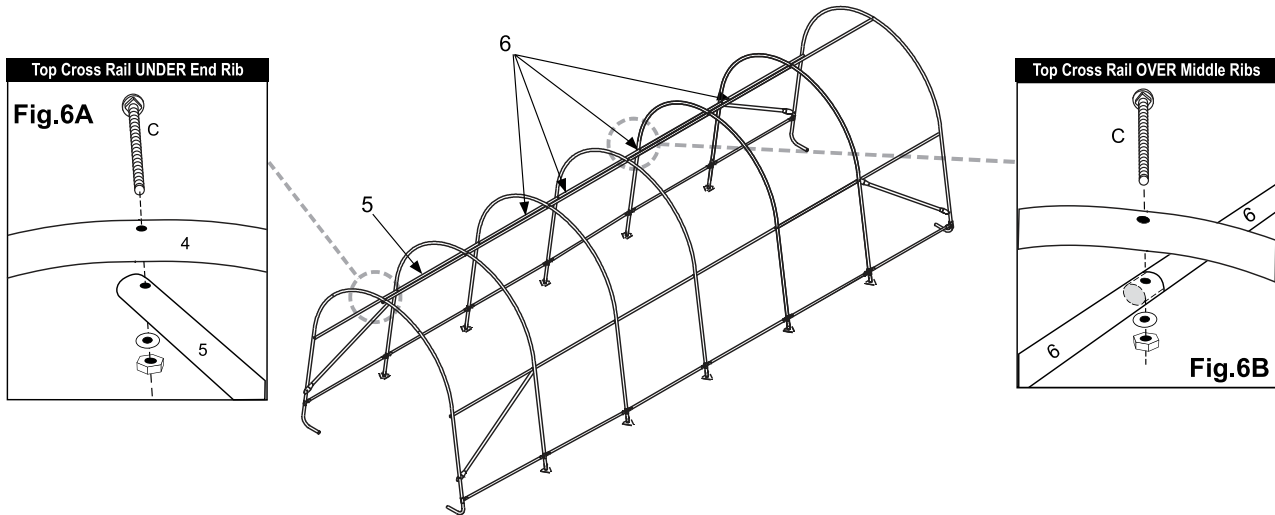

Fig. 5

## 6. INSTALL TOP CROSS RAIL

- A. Connect the plain end of the first cross rail (# 5 ) UNDER the front end rib and secure it with bolt (# C ) as shown in Fig.6 A. **HAND-TIGHTEN this bolt.**
- B. Connect the middle cross rails (# 6 ) to the first cross rail. Lay them OVER the top of the middle ribs and connect using bolt. Fig. 6B.
- C. The last cross rail (# 5 ) connects UNDER the end rib with bolt. Fig. 6A. **HAND-TIGHTEN this bolt.**



## 7. SQUARING UP THE FRAME

- A. Be sure that frame in its final location, which needs to be as flat and level as possible.
  - B. Measure across opposite corners.
- These distances must be equal to within 1 inch.**
- C. Check that the front and rear of the frame measures 10 feet in width.

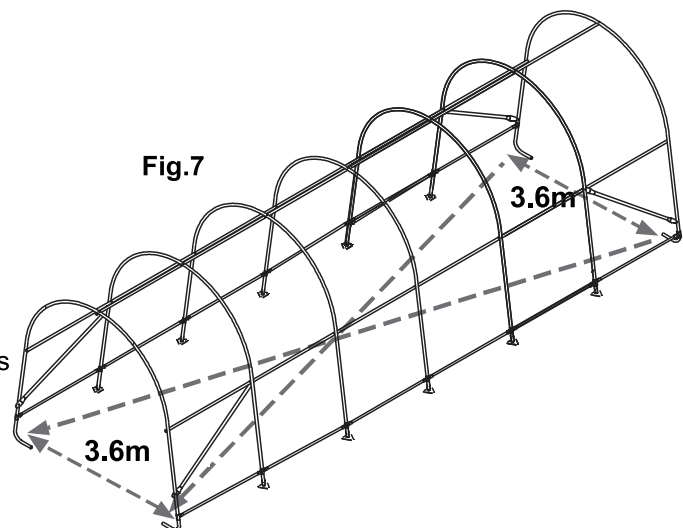

## 8. INSTALL AUGER ANCHORS

- A. Anchors must be placed inside shelter at the corner legs. Insert a 3/4-inch pipe or steel rod through the eyelet of the auger and turn the anchor clockwise until the eyelet is sticking out of the ground 1 to 2 inches allowing room to be anchored to the legs.
- B. Thread cable provided through the eyelet of the Anchor as indicated in figure 8. Secure the cable with the clamps provided.

*If the ground is too hard, dig a hole with a shovel or post hole tool. Optional: Fill with cement.*

Fig.8

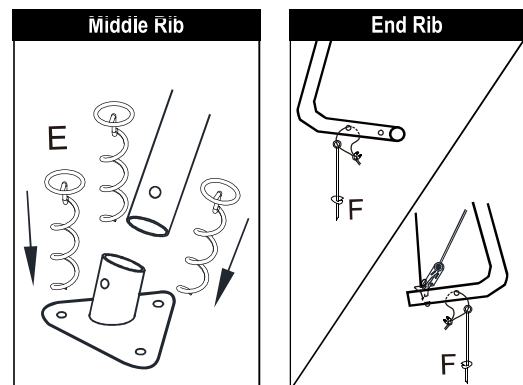

## 9. DOOR AND SOLID END WALL INSTALLATION

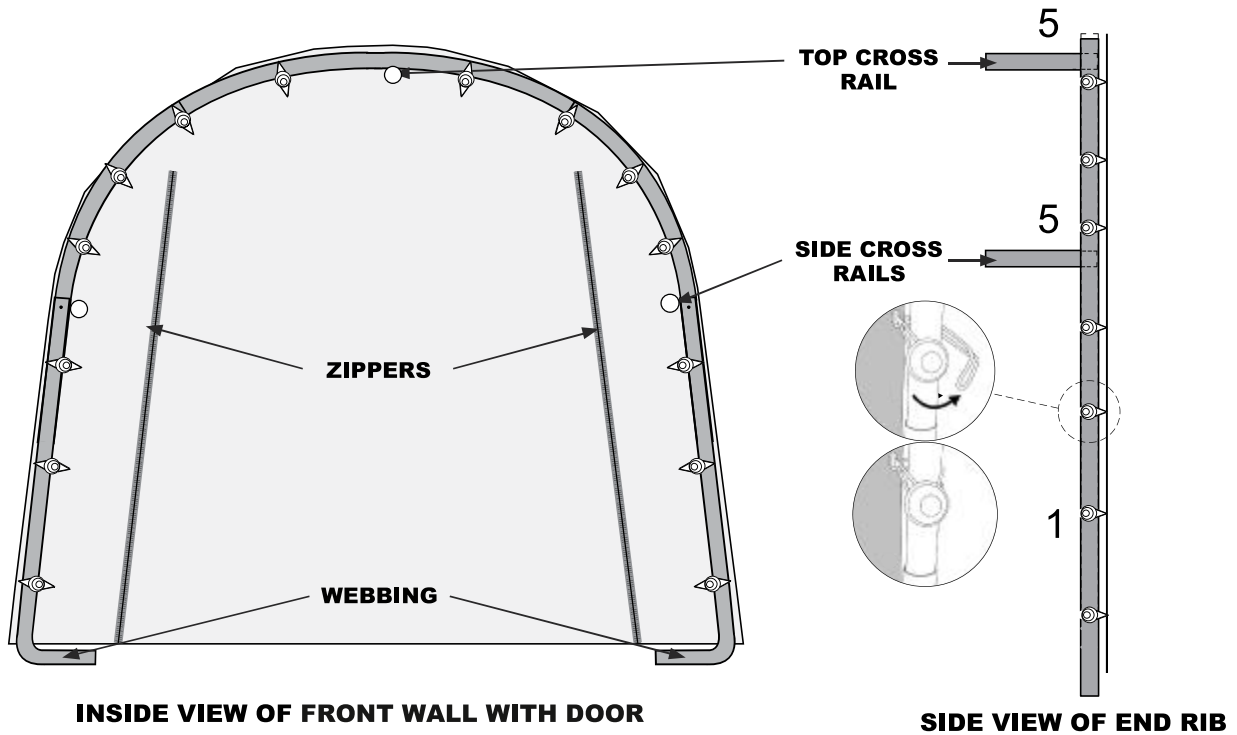
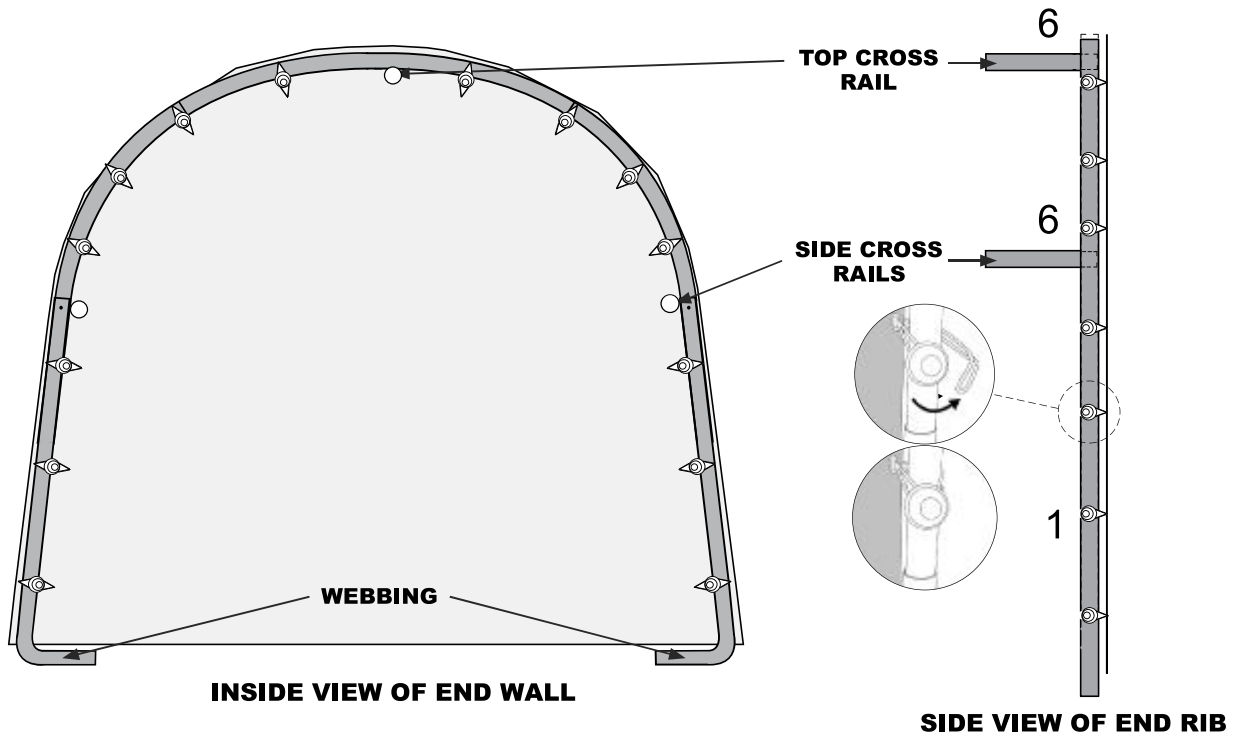

## **10. INSTALLING THE COVER ON THE FRAME**

END PANELS  
NOT SHOWN  
FOR CLARITY.

**A.** Lay the cover on the ground next to the frame with the inside of the cover (the side with the pipe pockets) facing down and the webbing on the front and rear of the corner of the building. Position the cover so that it is centered to the frame, front to back. Fig. 10A

**B.** Fold over the side closest to the frame so the pipe pocket is now accessible. Insert a cover pipe at the first middle rib from the front and the first middle rib from the rear so that it is inserted in the pipe pocket on both ends of the pipe but the center of the pipe is exposed. For long buildings it may be necessary to use additional pipes in the middle. Fig. 10B.

**C.** Tie the rope on each of the exposed pipes and throw the other end of the rope over the frame. Fig. 10C.

**D.** Move to the other side of the frame and pull the cover over the frame with the rope. This may require two or more people. Fig. 10D.

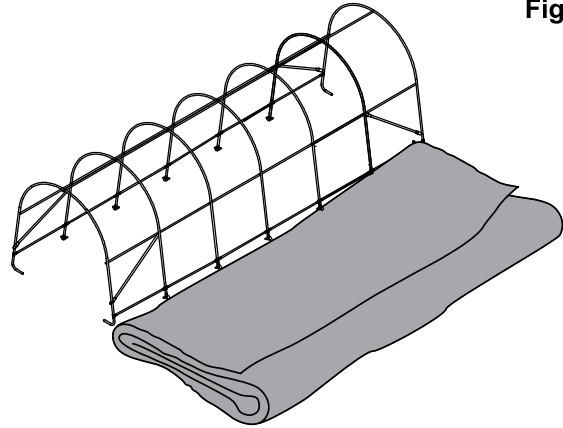

Fig.10A

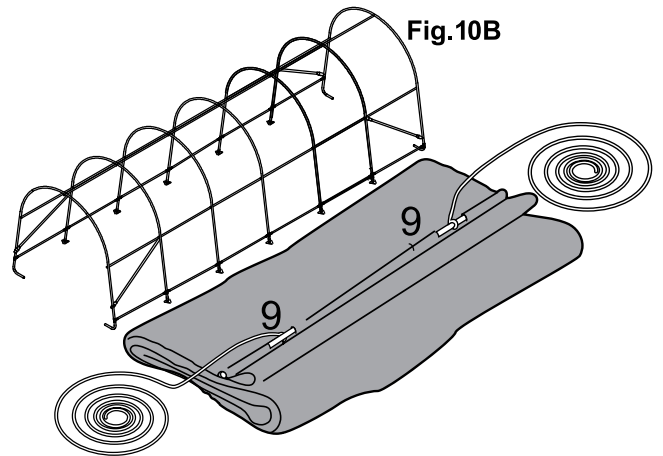

Fig.10B

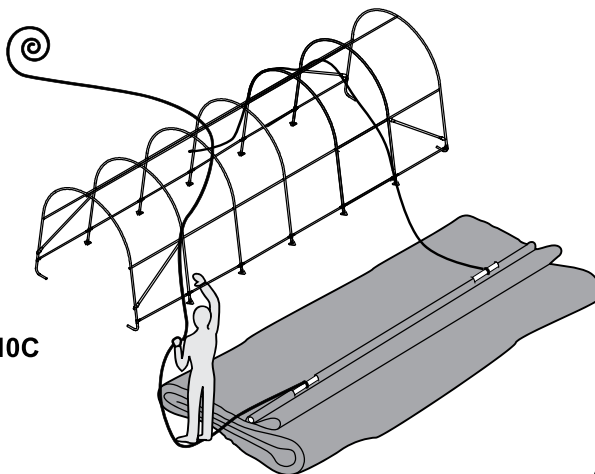

Fig.10C

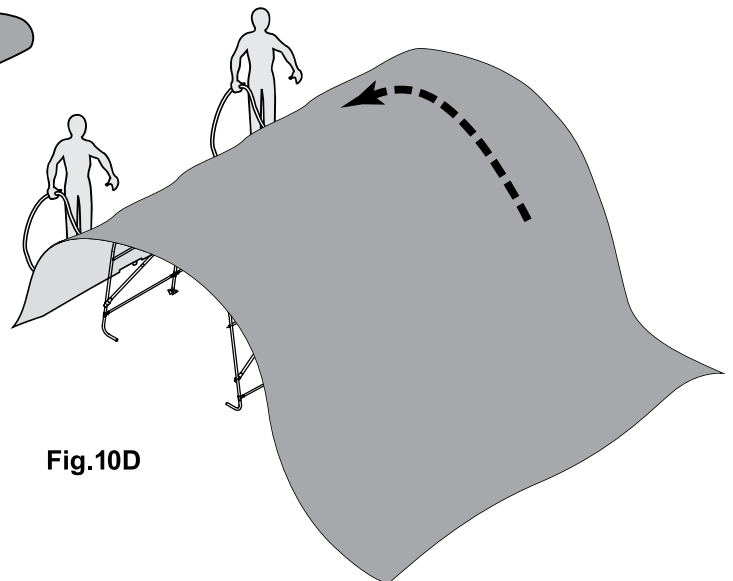
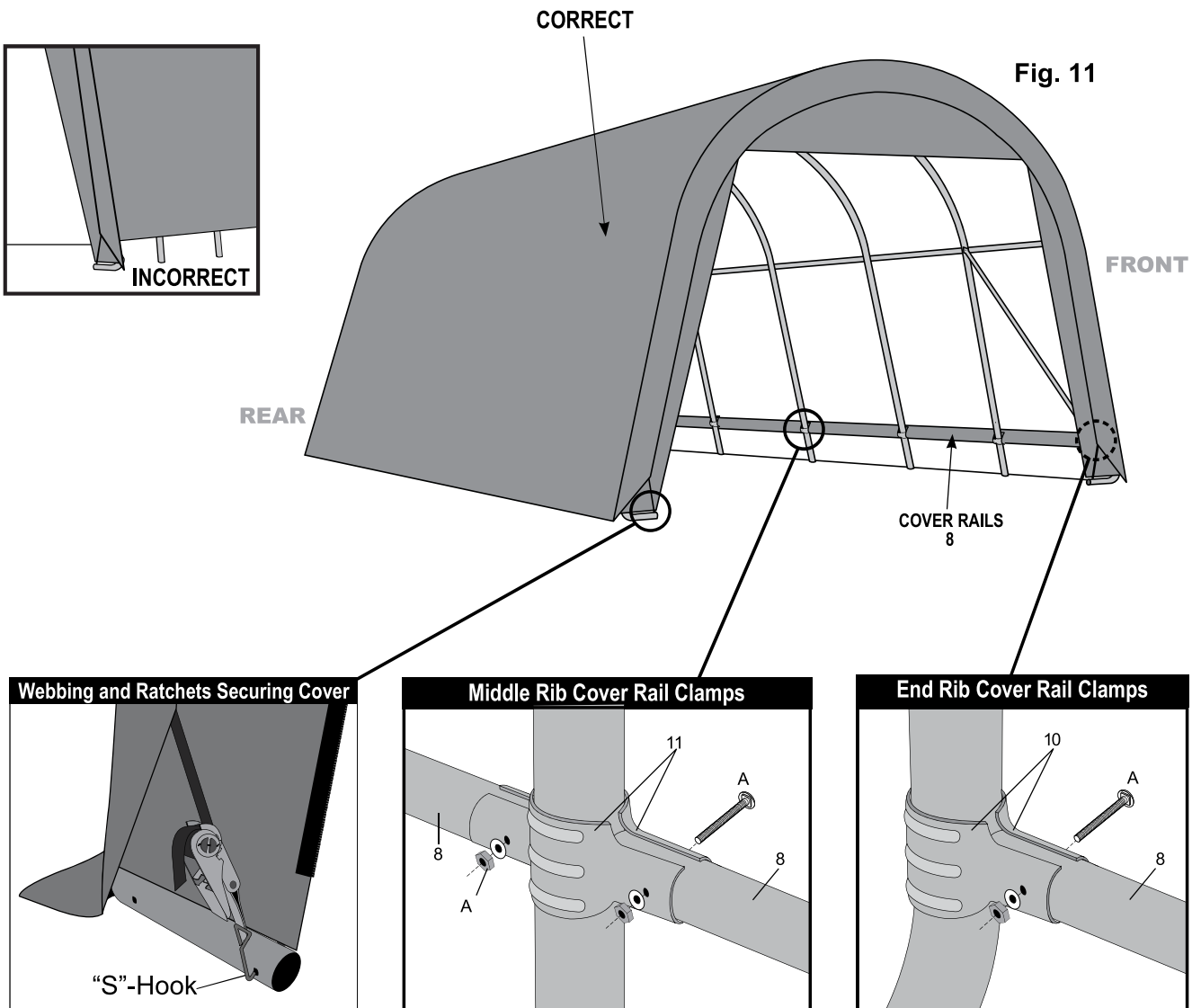

Fig.10D

**NOTE: CHECK THAT YOUR COVER IS CORRECTLY PLACED ON THE FRAME.**

## 11. INSTALLING COVER AND COVER RAILS

- A. Make sure cover is centered on frame. There should be an equal amount of overhang at all four corners.
- B. Insert the "S"- Hook on ratchet into hole on the leg bend. Insert the webbing into the spindle of the ratchet and pull tight. Wind the ratchet so that the webbing overlaps itself.
- C. Slide cover rails (# 8 ) through fabric pockets at each leg and reattach with clamps to each leg. Repeat this on other side. Push down on cover rails to tighten cover, before tightening bolts completely.
- D. Check and tighten Ratchets and Cover Rails monthly to ensure the cover is tight.



## ng Ratchet Tie-Downs

these instructions in the pages that follow.

l the strap through the Ratchet's (8)  
: as far as it will go

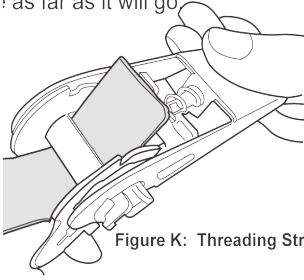

Figure K: Threading Strap through Spindle

t the S-hook of the Ratchet into  
ole in the Corner Leg (6).

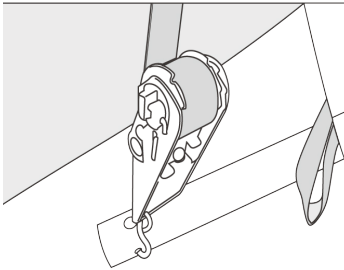

Figure L: Inserting Hook into Corner Leg

Lift and lower the Ratchet's handle to wind  
and tighten the strap onto the spindle.

7

~

## Releasing Ratchet Tie-Downs

1. Depress the spring-loaded bar on the handle.
2. Open Ratchet handle completely.
3. Unwind the strap.

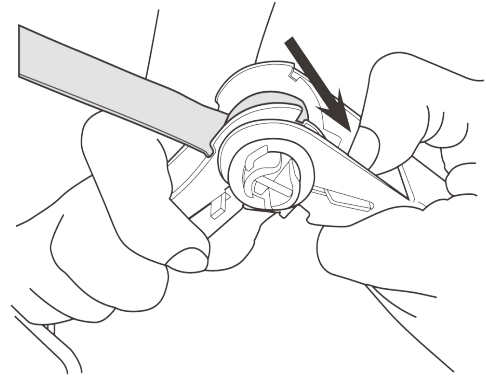

Figure N: Releasing Ratchet

## ATTENTION:

1. Please check the manual carefully and make sure you have received all the parts.
2. If there is any missing, please let us know the letter of the parts you need.
3. If there is any damage, please send clear photos to us, we will check and offer you best solution soon.