

SANDBOX

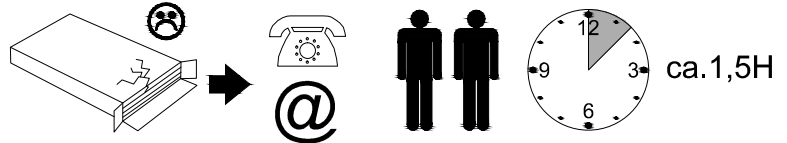

- (D) Montageanleitung
- (GB) Assembly Instructions
- (FR) Notice de montage
- (IT) Istruzioni di montaggio
- (NL) Handleiding voor de montage
- (PL) Instrukcja montażu
- (CZ) Montážní návod
- (SK) Návod na montáž
- (HU) Szerelési útmutató
- (RO) Instrucțiuni de montaj
- (TR) Montaj talimatı
- (RU) Инструкции по монтажу

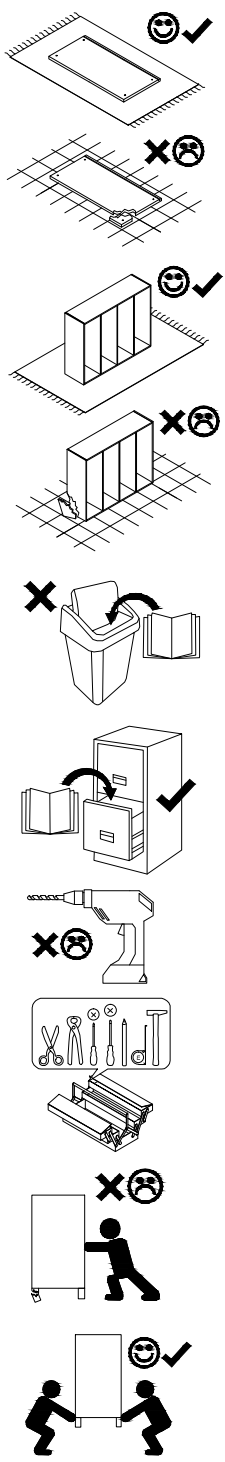
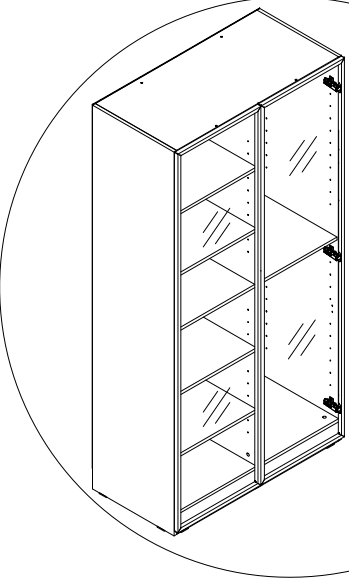
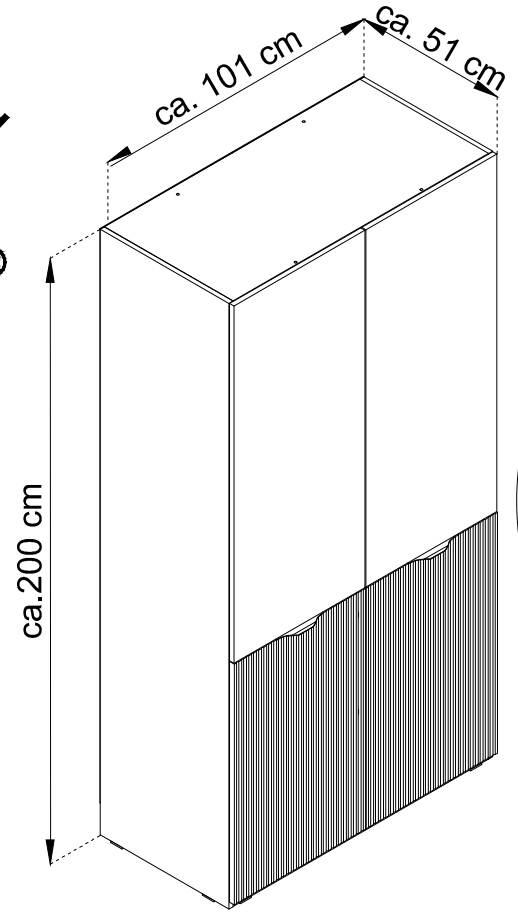
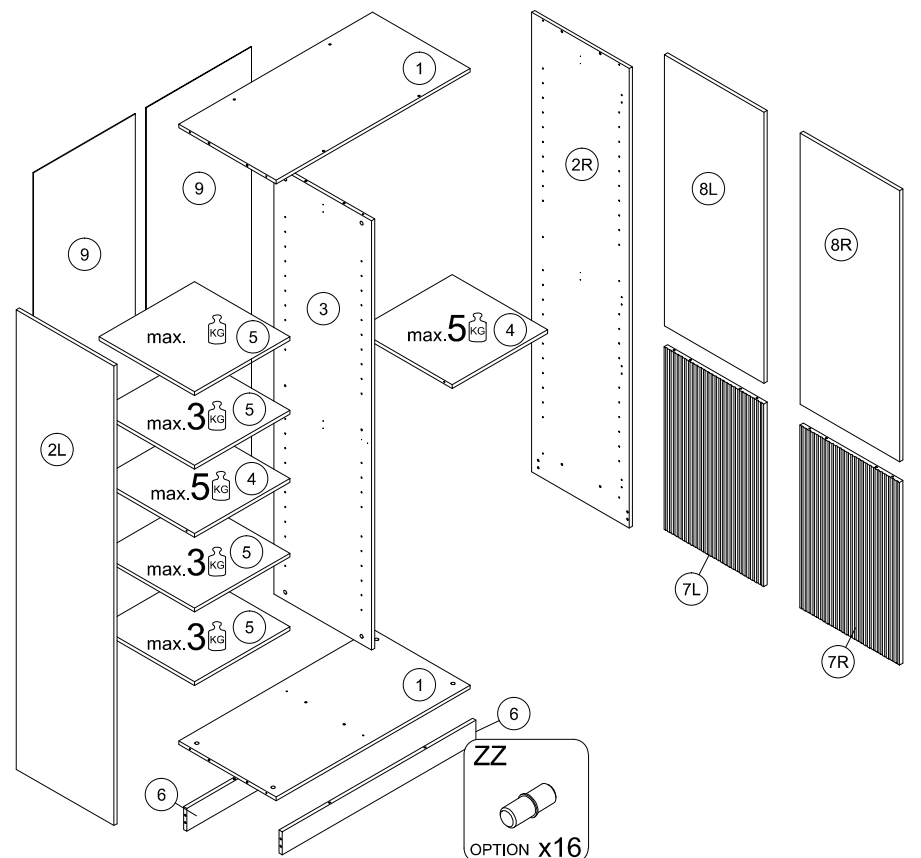

A	8x32	B	x24	C	x20	Z	x20	ZZ	x16
B1	x2	T	x4	DR	L-470	TA	x1	SP	x8
N	3x20	ZC	x15	NS	3,5x13	LED OPTION	x4	WTY OPTION	x1
H0	SENTO / NOVA X8	PH	SENTO / NOVA X8	U	SENTO / NOVA X2	TD	SENTO / NOVA X8	NS	3,5x13
H0	ANTISOL / FLUTES	PHR	ANTISOL / FLUTES	WR	ANTISOL / FLUTES	KG	TITUS	NS	3,5x13
	x6		x6		x12		x2		x4



1	974	490	16	x2	2/2
2L	2000	490	16	x1	1/2
2R	2000	490	16	x1	1/2
3	1868	490	16	x1	1/2
4	479	479	16	x2	2/2
5	479	465	16	x4	2/2
6	974	100	16	x2	2/2
7L	795	500	18	x1	1/1
7R	795	500	18	x1	1/1
8L	1180	500	16	x1	1/1
8R	1180	500	16	x1	1/1
9	1896	502	2.5	x2	1/2

08.03.2024

! Uwaga • Upozornění • Achtung • Attention • Caution • Figyelem !
 Attenzione • Opgelet • Внимание • Atenție • Upozornenie • Dikkat !

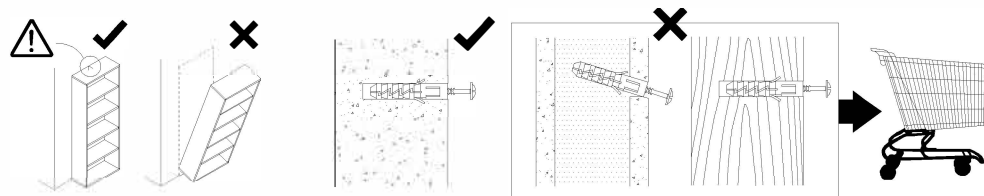
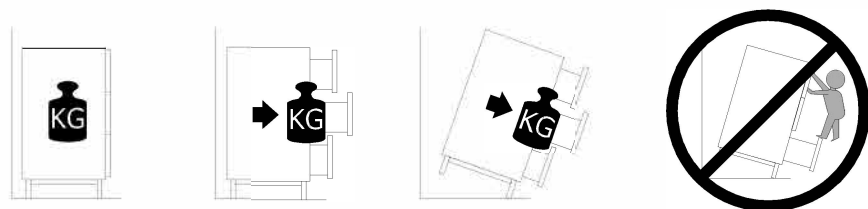

! Uwaga • Upozornění • Achtung • Attention • Caution • Figyelem !
 Attenzione • Opgelet • Внимание • Atenție • Upozornenie • Dikkat !

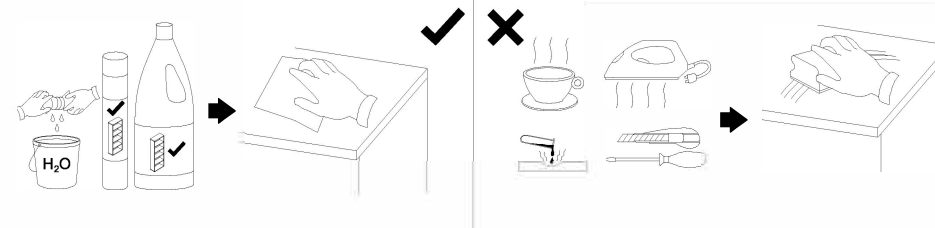
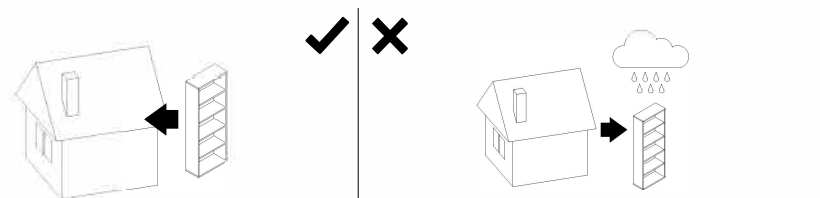

PL	Mocowanie do ściany jest jednocześnie zabezpieczeniem przed przewróceniem - koniecznie zamontować! Do niektórych rodzajów ścian koniecznie zastosować specjalne kołki mocujące.
CZ	Montáž na stěnu slouží jako ochrana proti převrnutí - bezpodmínečně umístěte! U některých typů stěn může být zapotřebí speciální hmoždinka!
DE	Wandbefestigung dient als Kippschutz - unbedingt anbringen! bei einigen Wandtypen kann ein Spezialdübel erforderlich sein!
GB	The wall fastening serves to prevent tipping - be absolutely sure to mount it! For certain wall types, a special wall plug may be necessary!
FR	La fixation murale sert de protection contre le basculement - à installer impérativement! Pour certains types de murs il faut des chevilles spéciales!
NL	Bevestiging aan de muur dient als kantelbescherming - zeker en vast bevestigen! Bij enkele muurtypes is een speciale plug misschien vereist!
IT	Il fissaggio alla parete serve da protezione anti-ribaltamento-attaccarla assolutamente! Per alcune strutture di parete può essere necessario un tassello speciale!
HU	A termékét a falhoz kel rögzíténi, különben az felborulhat! Egyes faltípusoknál speciális tiplít kell használni!
RU	Обязательно установите крепление на стене во избежание опрокидывания! Для некоторых типов стен может потребо- ваться специальный дюбель!
RO	Sistemul de fixare la perete servește ca protecție la răsturnare - de montat obligatoriu! Pentru unele tipuri de pereți este posibil să fie necesar un diblu special!
SK	Upevnenie ne stenu slúži ako ochrana proti prevráteniu - bezpodmienečne použite! Pre niektoré druhy stien môže byť potrebná špeciálna hmoždinka!
TR	Duvardaki sabitleme, devrilmeye karşı bir emniyet tedbiridir ve mutlaka monte edilmelidir! Bazı duvar tiplerinde bunun için özel bir dübel gerekli olabilir!

PL	Czyszczenie należy wykonać wyłącznie za pomocą ściereczki lub lekko nawilżonego ręcznika. Nie stosować środków czyszczących do szorowania.
CZ	Čistění je nutné vykonávat výhradně pomocí utěrky nebo lehce navlhlého ručníku. Nepoužívejte čističí prostředky obsahující abrazivní částice.
DE	Bitte nur mit einem Staubtuch oder leicht feuchtern Lappen reinigen. Keine scheuernden Putzmittel verwenden.
GB	Please only clean with a duster or damp cloth. Do no use any abrasive cleaners.
FR	Le nettoyage se fait uniquement à l'aide d'un torchon ou d'une serviette légèrement mouillée.
NL	Reinig alleen met een stofdoek of een lichtjes vochtige doek. Gebruik geen schurende poetsmiddelen.
IT	Pulire esclusivamente con un panno o un asciugamano umido.
HU	A tisztítás kizárólag törleruha vagy enyhén nedvesített törölköző segítségével végezhető. Súroló hatású tisztítószerket nem szabad használni.
RU	Очищайте от пыли тряпкой или слегка влажной ветошью. Не допускается применение чистящих средств, не пред-назначенных для ухода за мебелью.
RO	Curățarea trebuie efectuată numai cu o cârpă sau cu un prosop ușor umezit. Nu utilizați agenți de curățare abrazivi.
SK	Čistení je nutné vykonávať výhradne pomocí utierky alebo ľahko zvlhnutým ručníkom. Nepoužívajte čistiaci prostriedky obsahujúci abrazívni častice.
TR	Lütfen sadece bir toz bezilye veya hafif nemli yumuşak bir bezle siliniz. Aşındırıcı temizlik malzemeleri kullanmayınız.

1

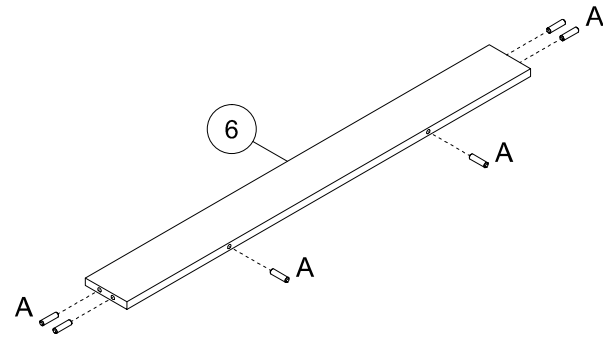
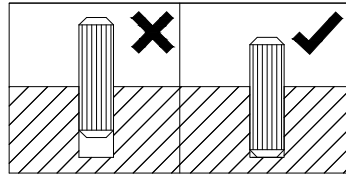

x2

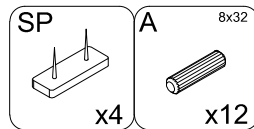
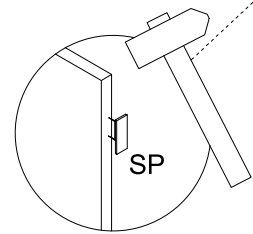
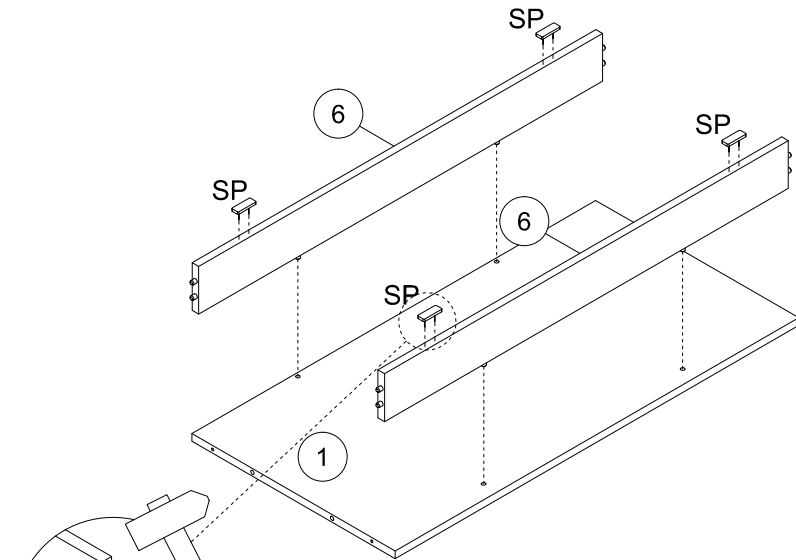

2

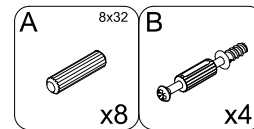
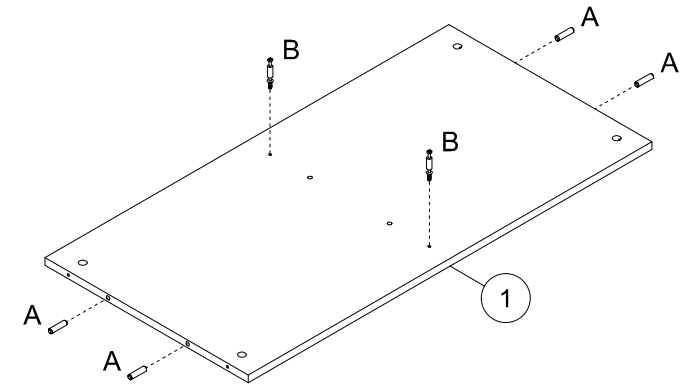
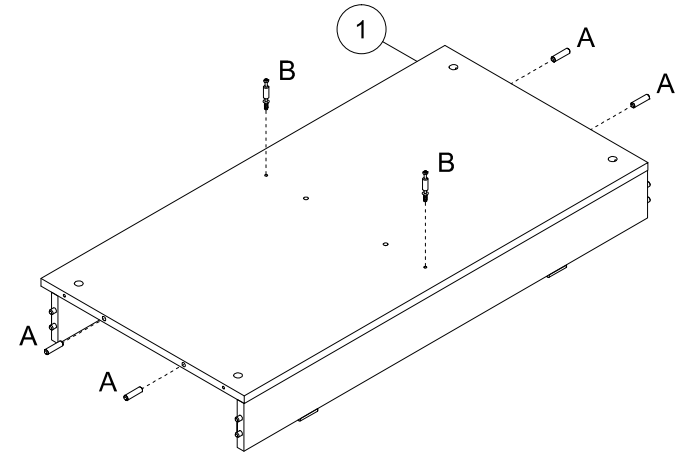
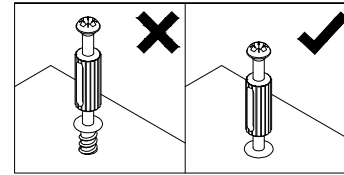

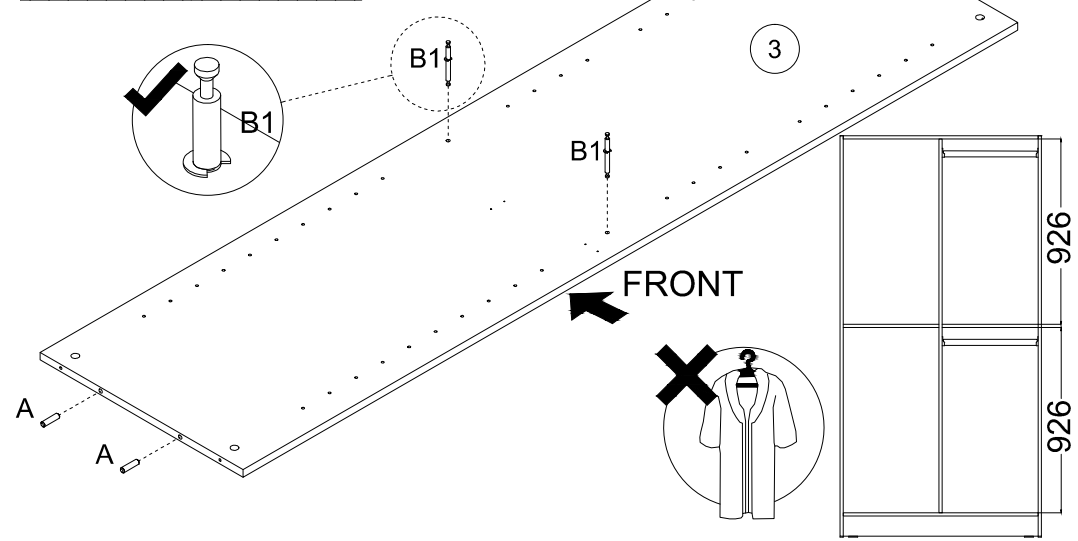
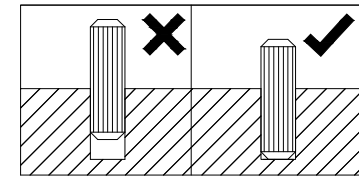
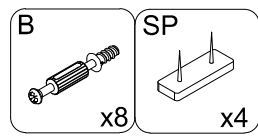
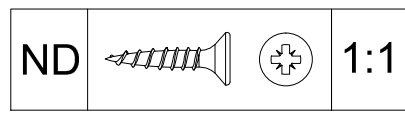
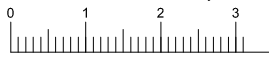
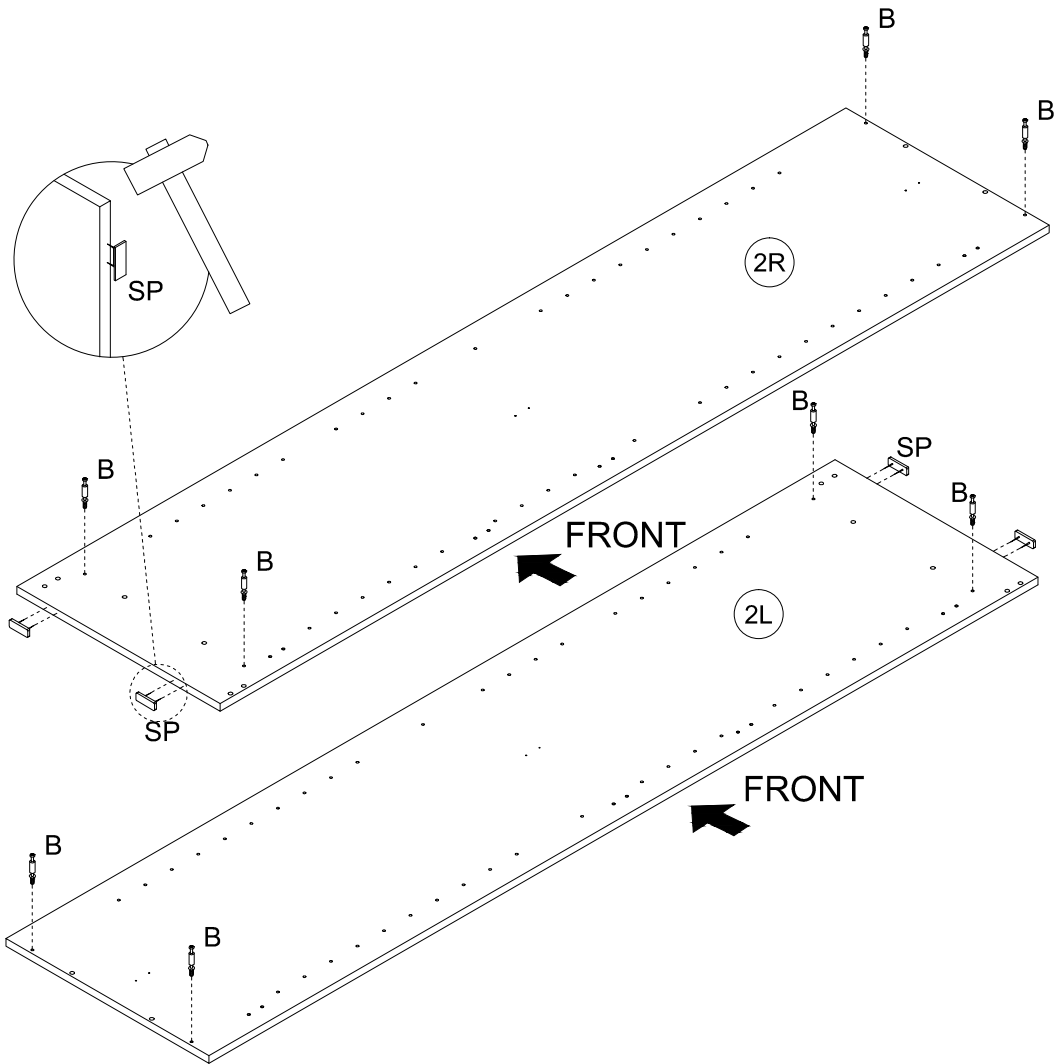
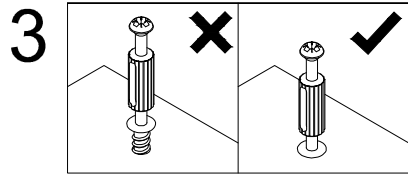

OPTION

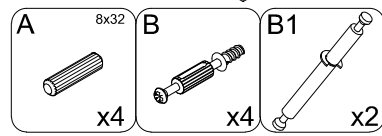
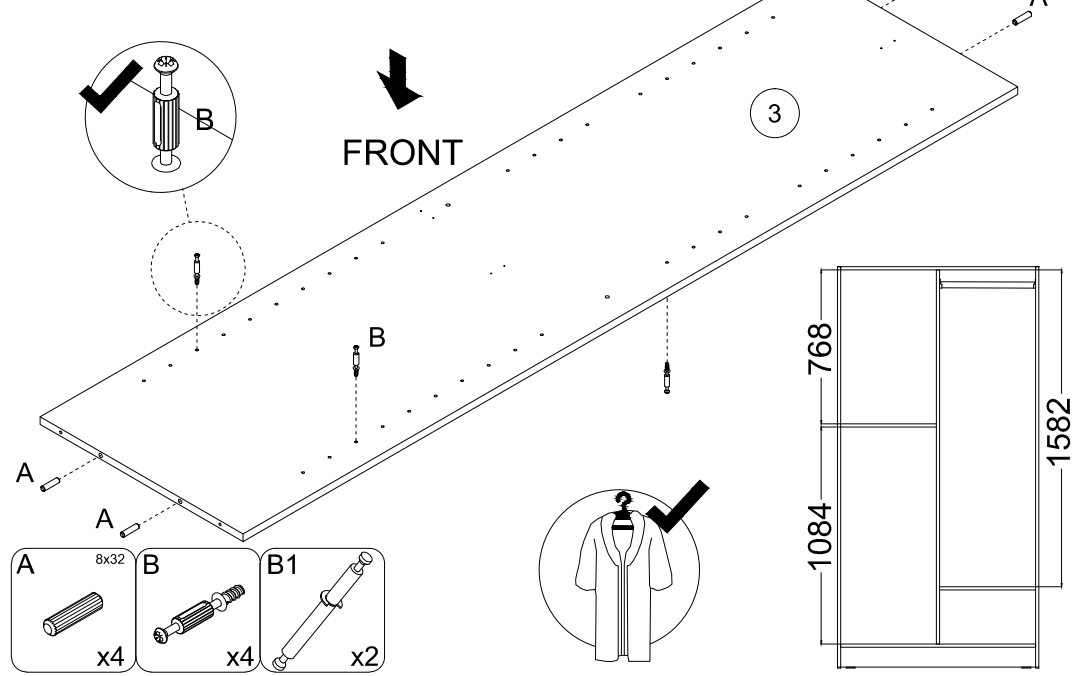

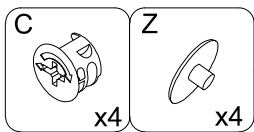
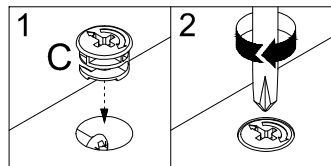
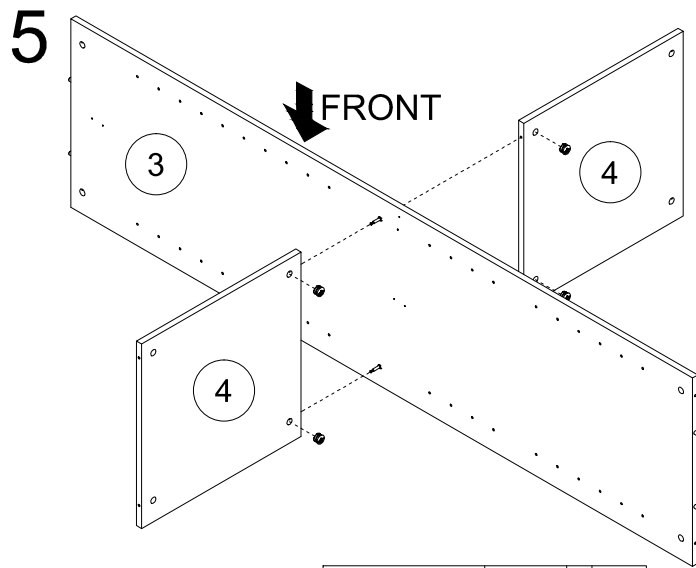

OPTION

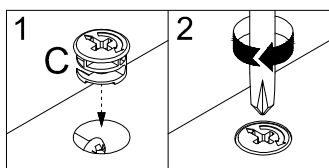
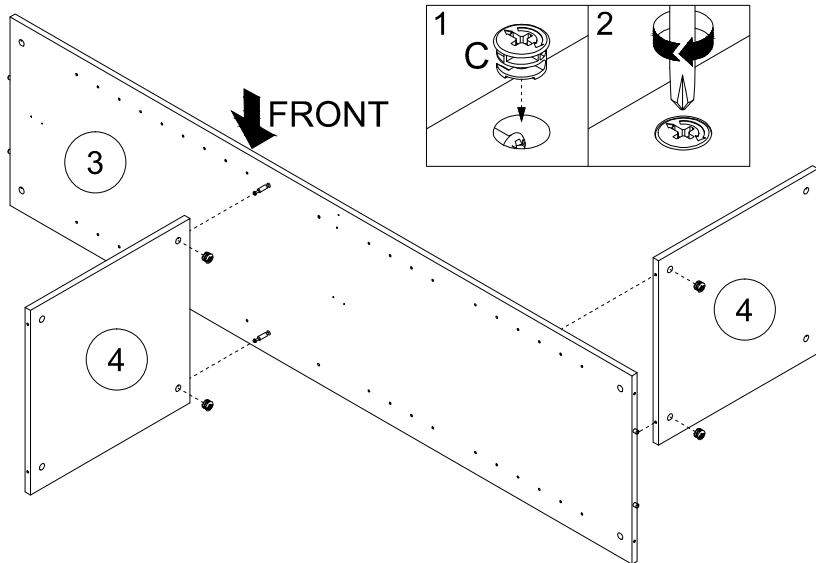

OPTION

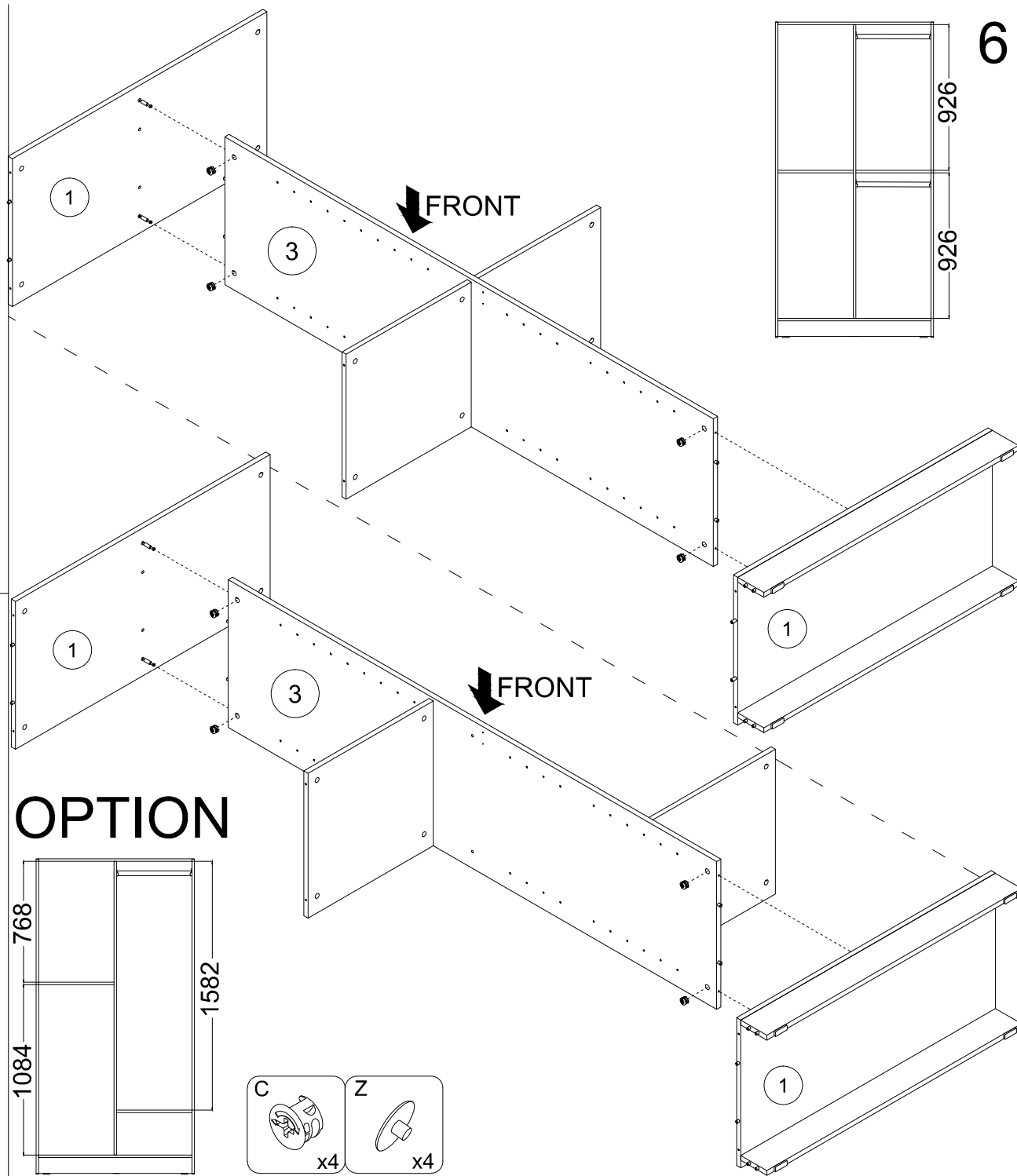
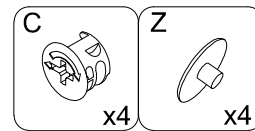
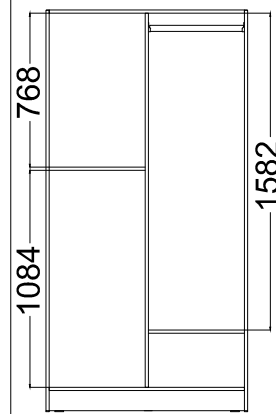

6

OPTION

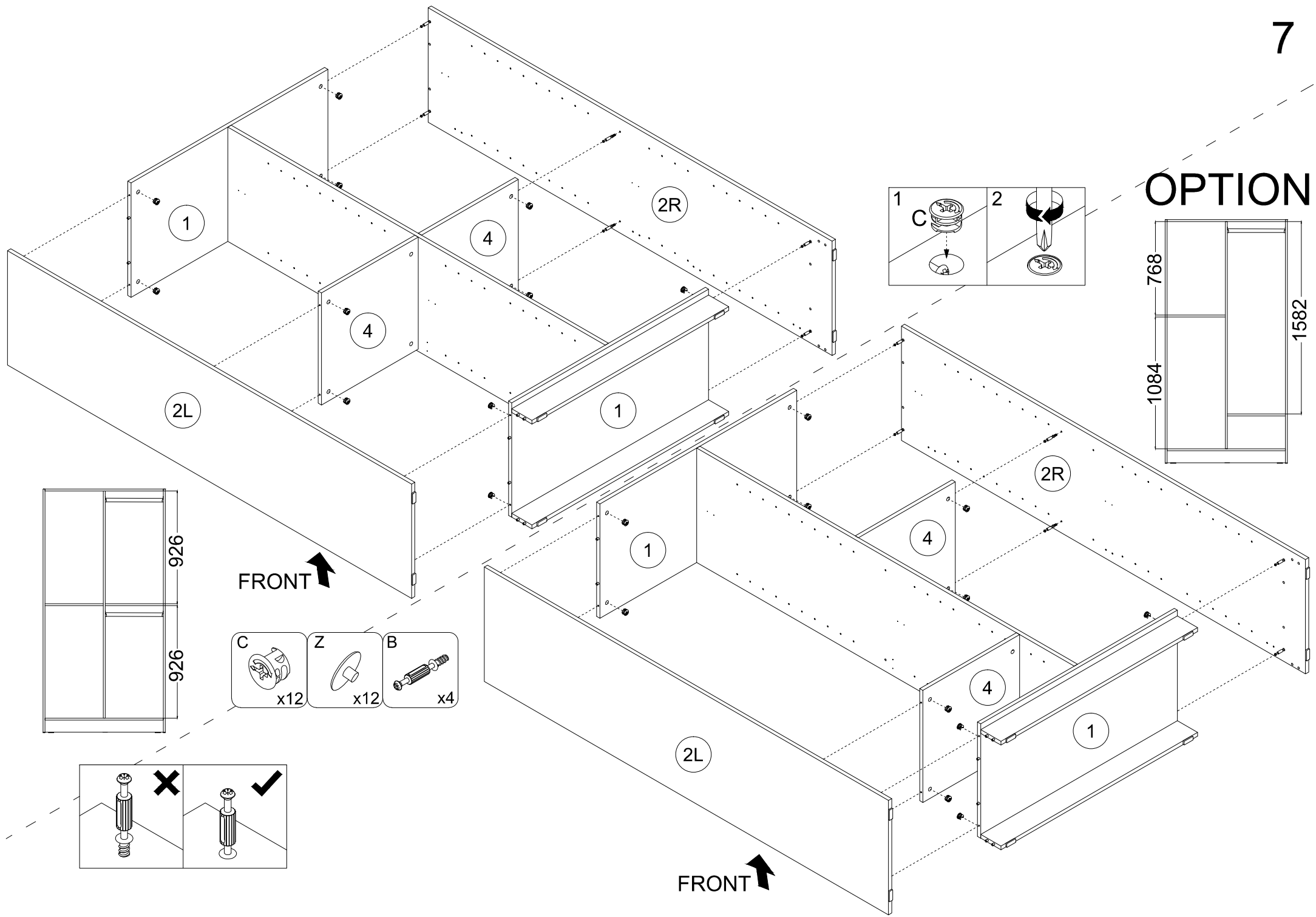

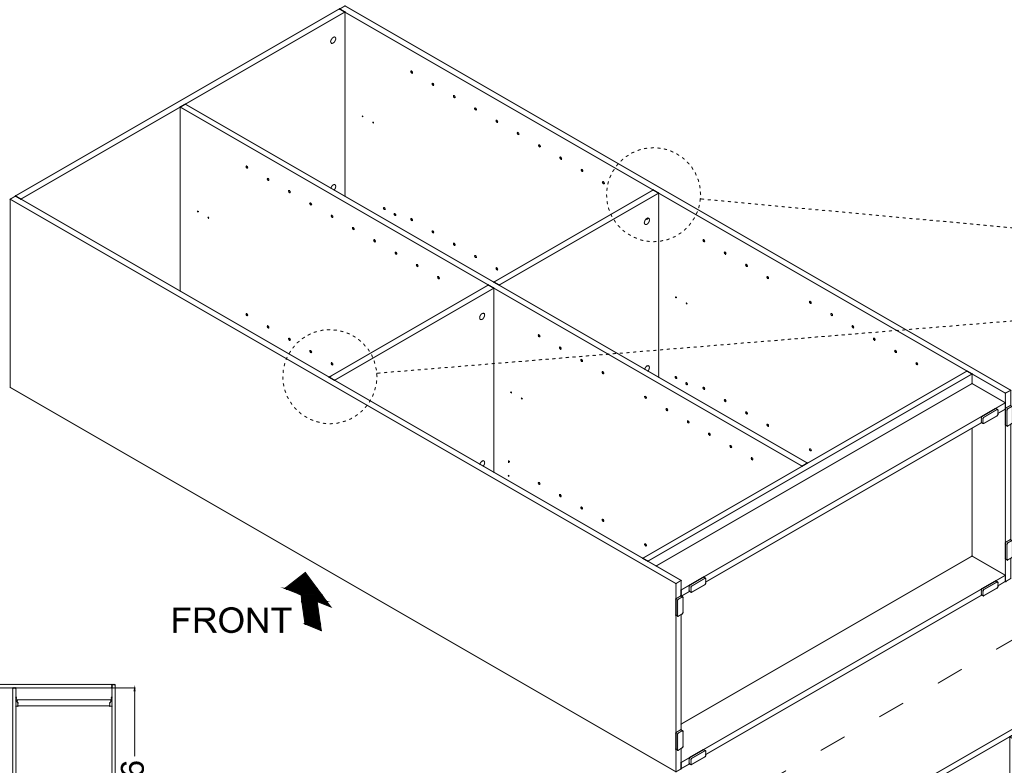

FRONT 

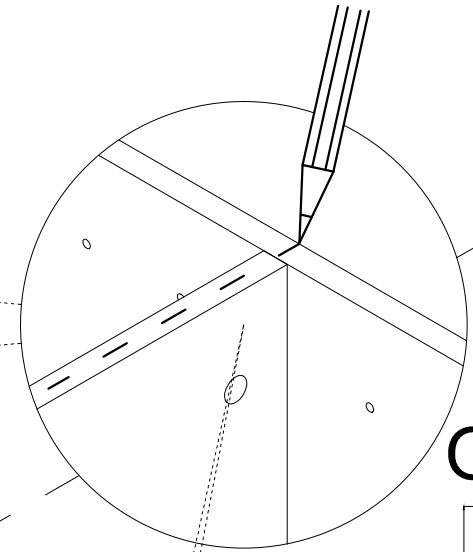
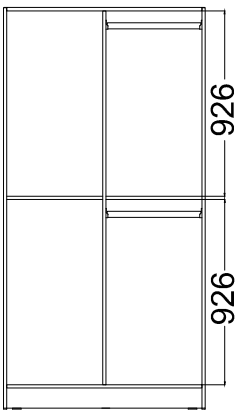

OPTION

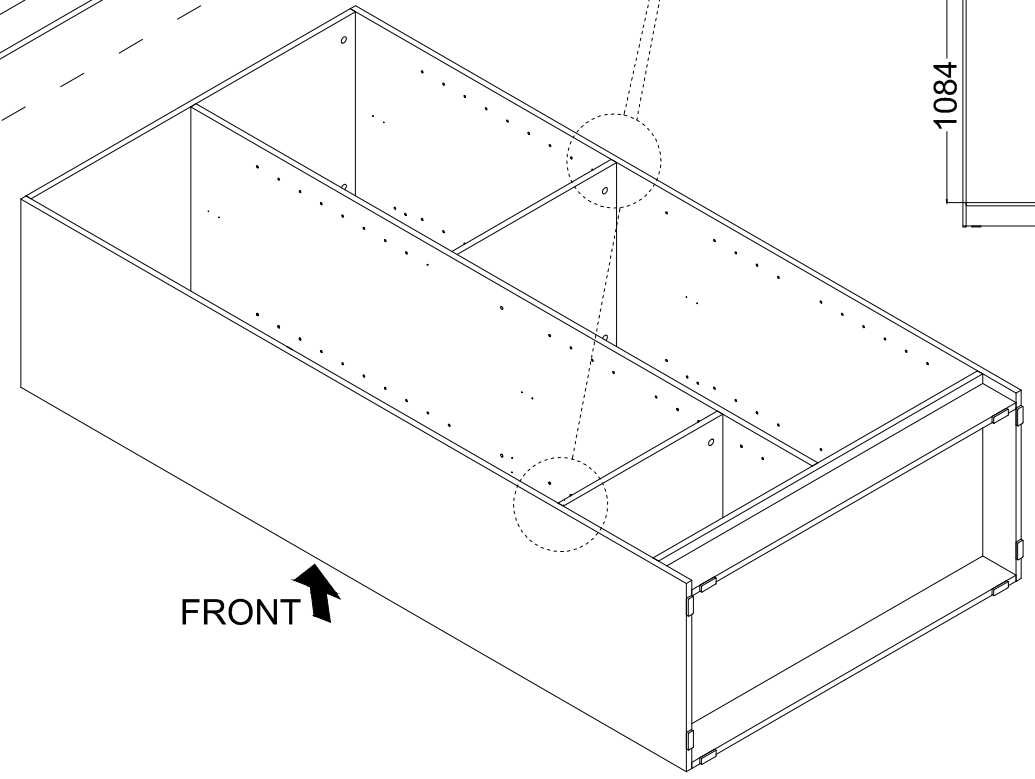
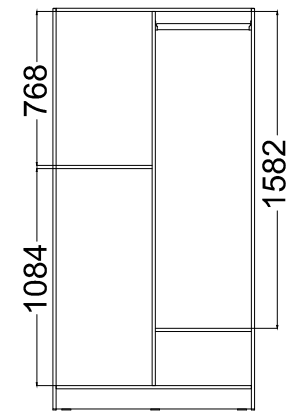

FRONT 

9

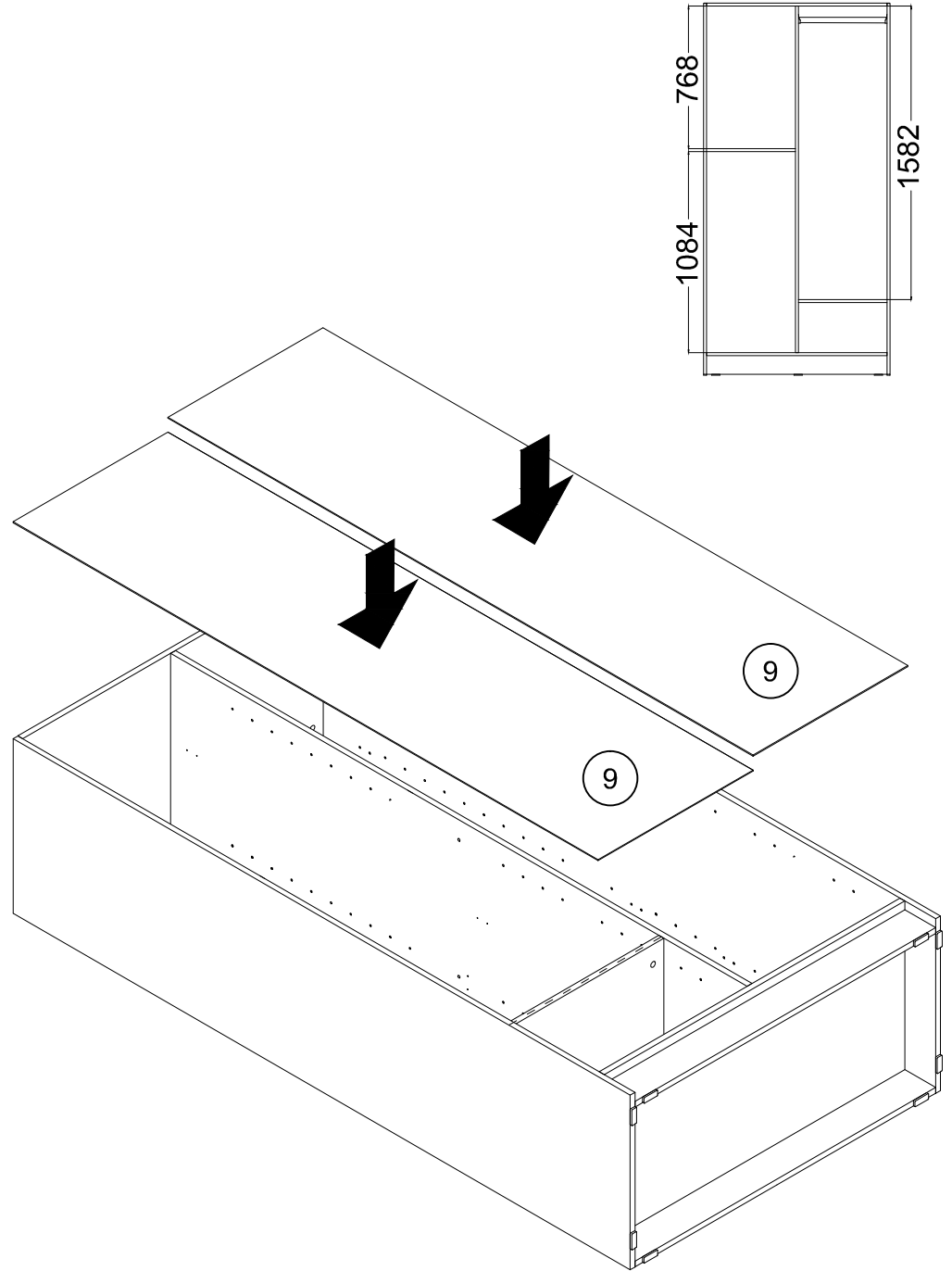
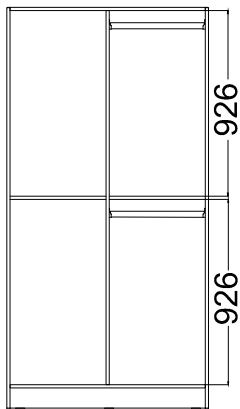
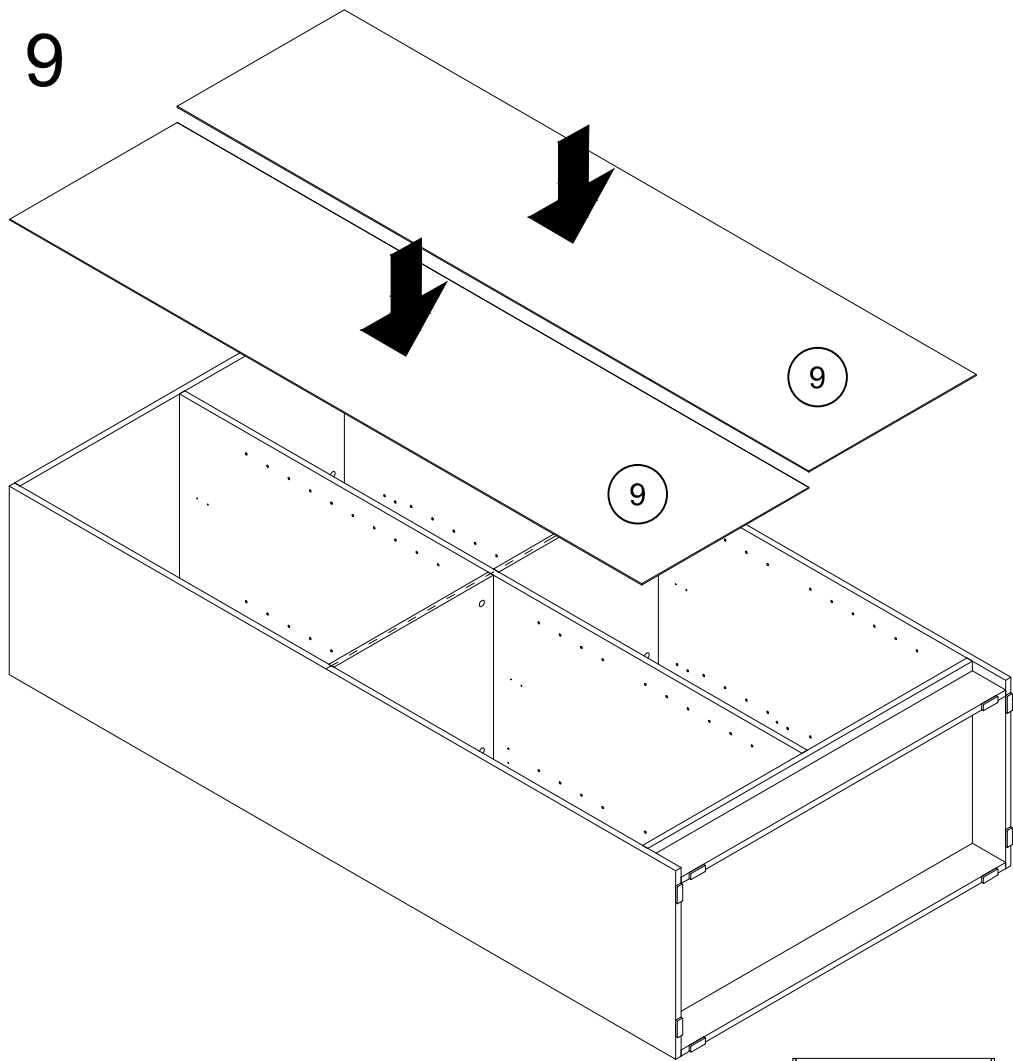

10

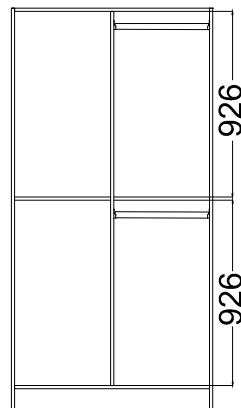
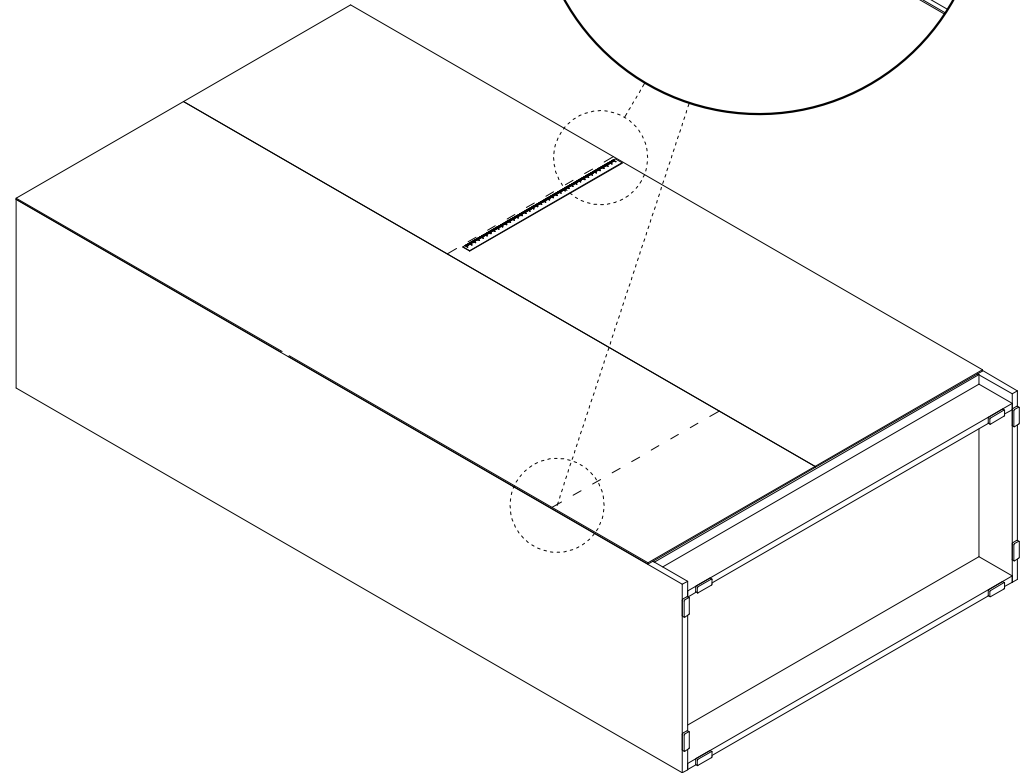
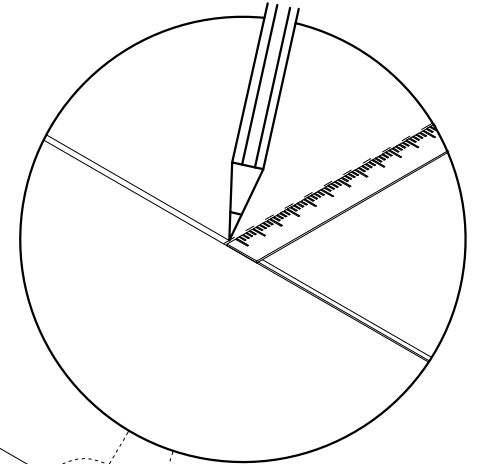
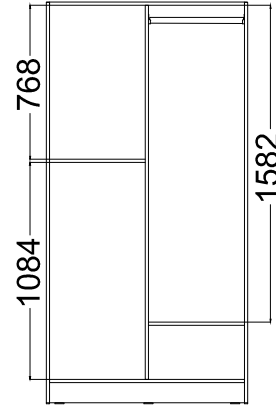
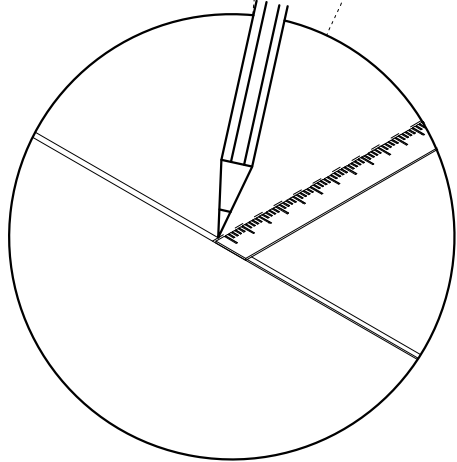
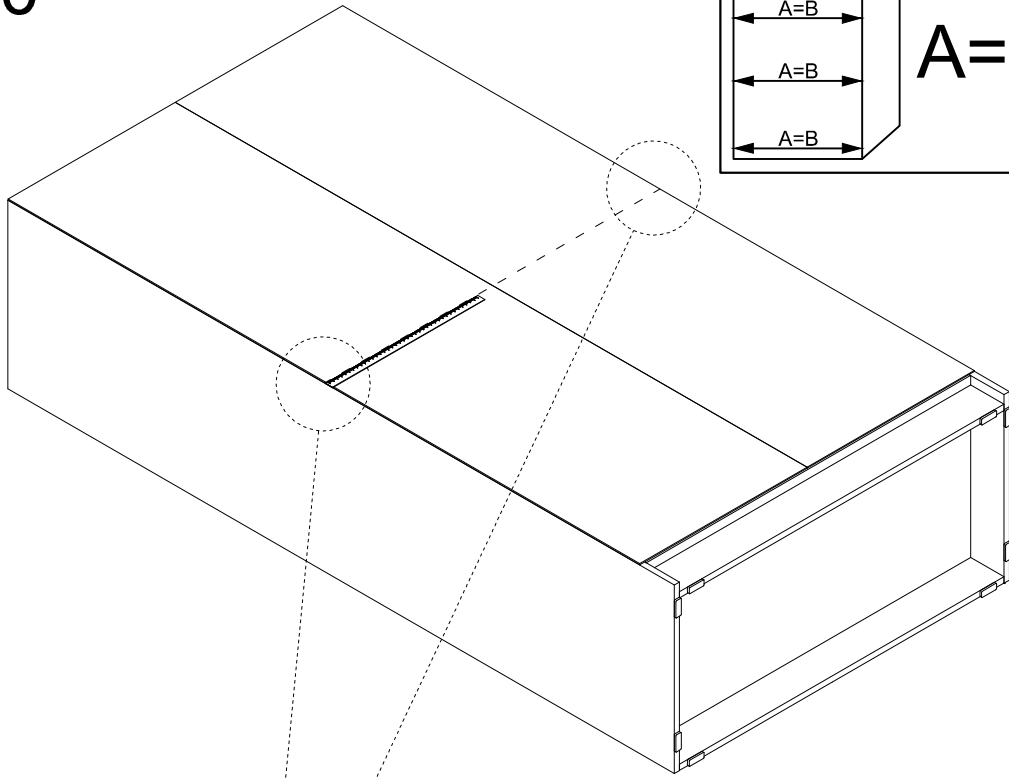
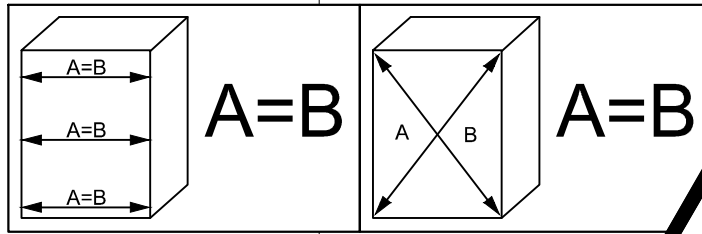

11

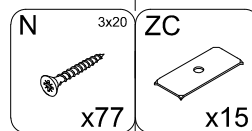
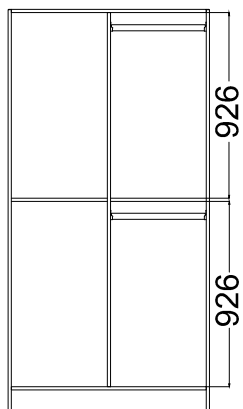
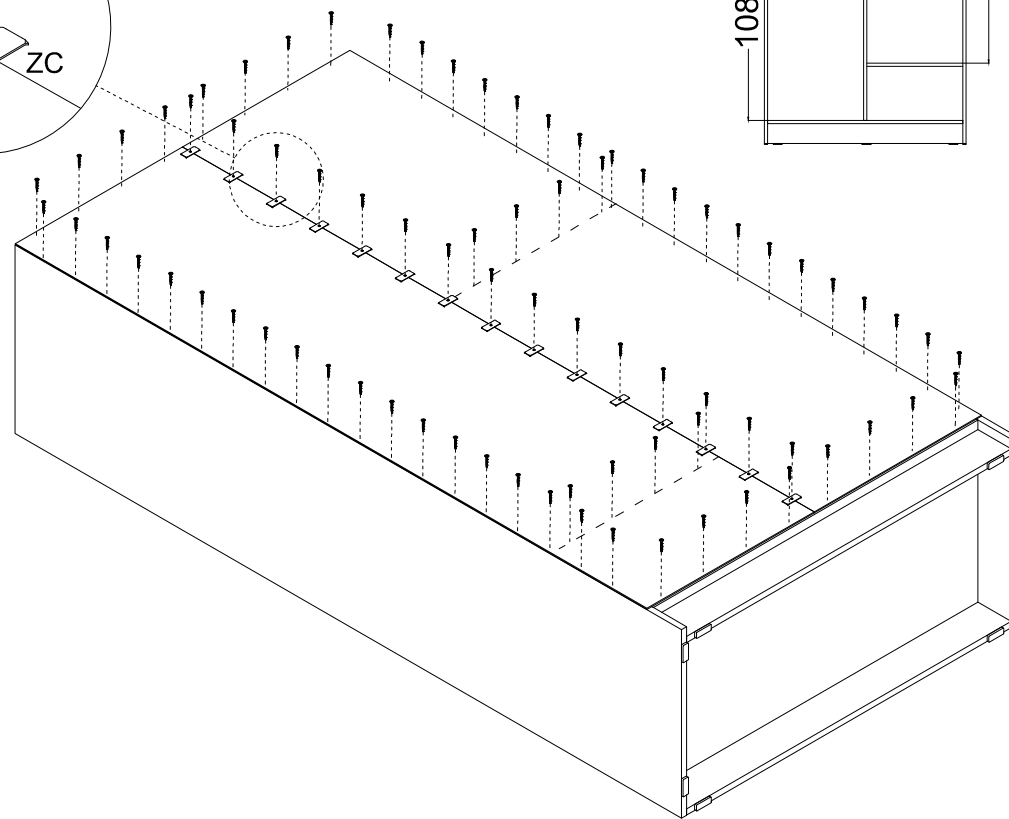
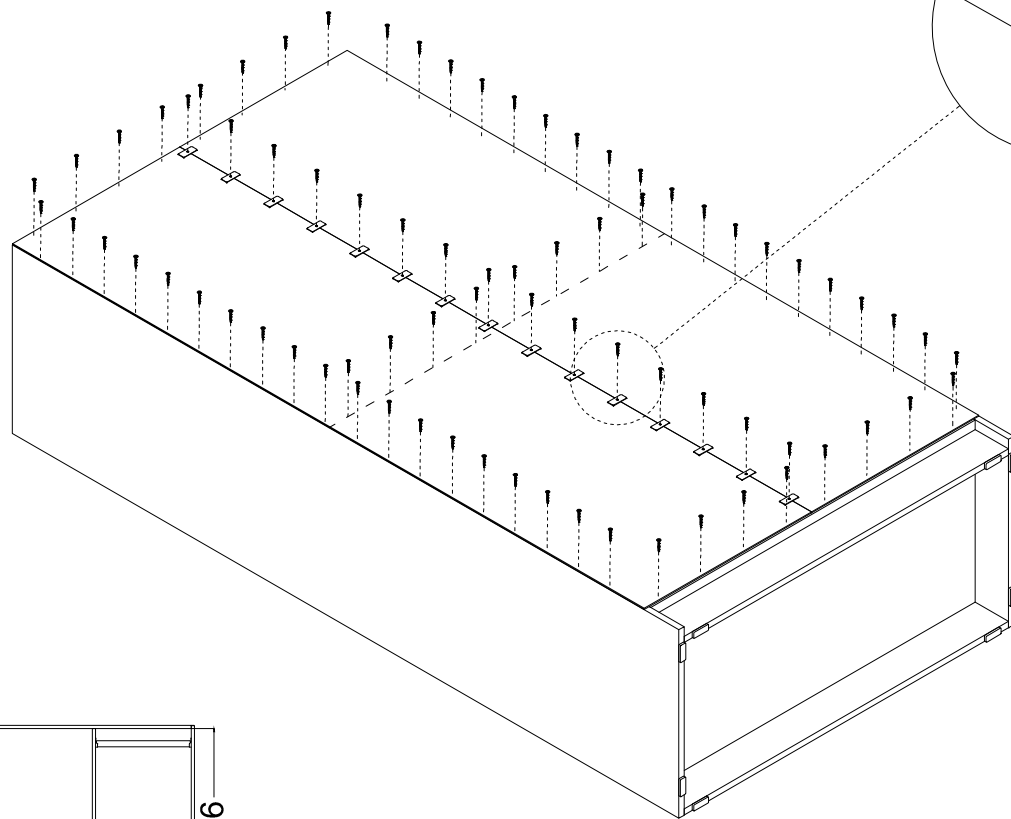
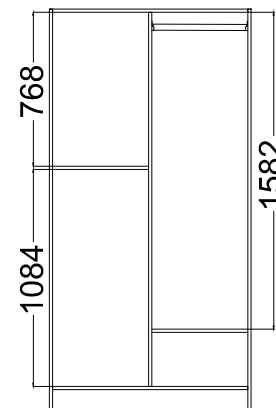
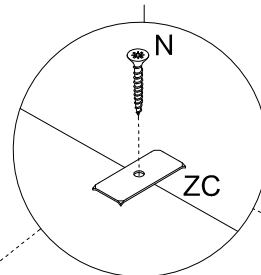
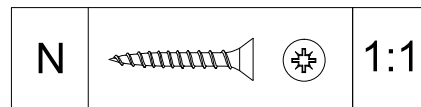
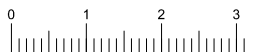

OPTION LED

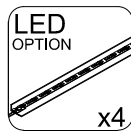
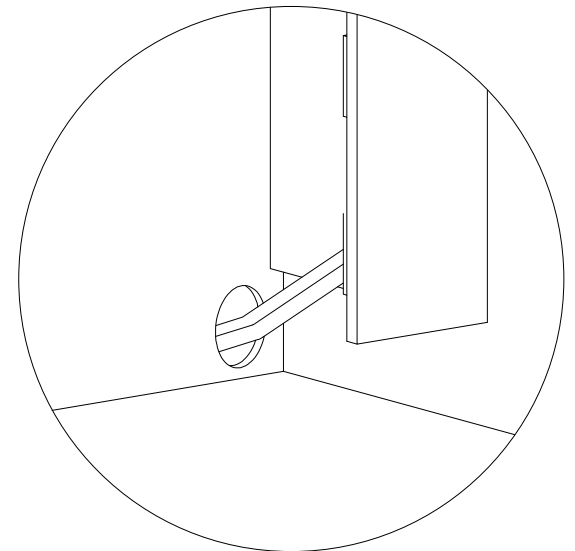
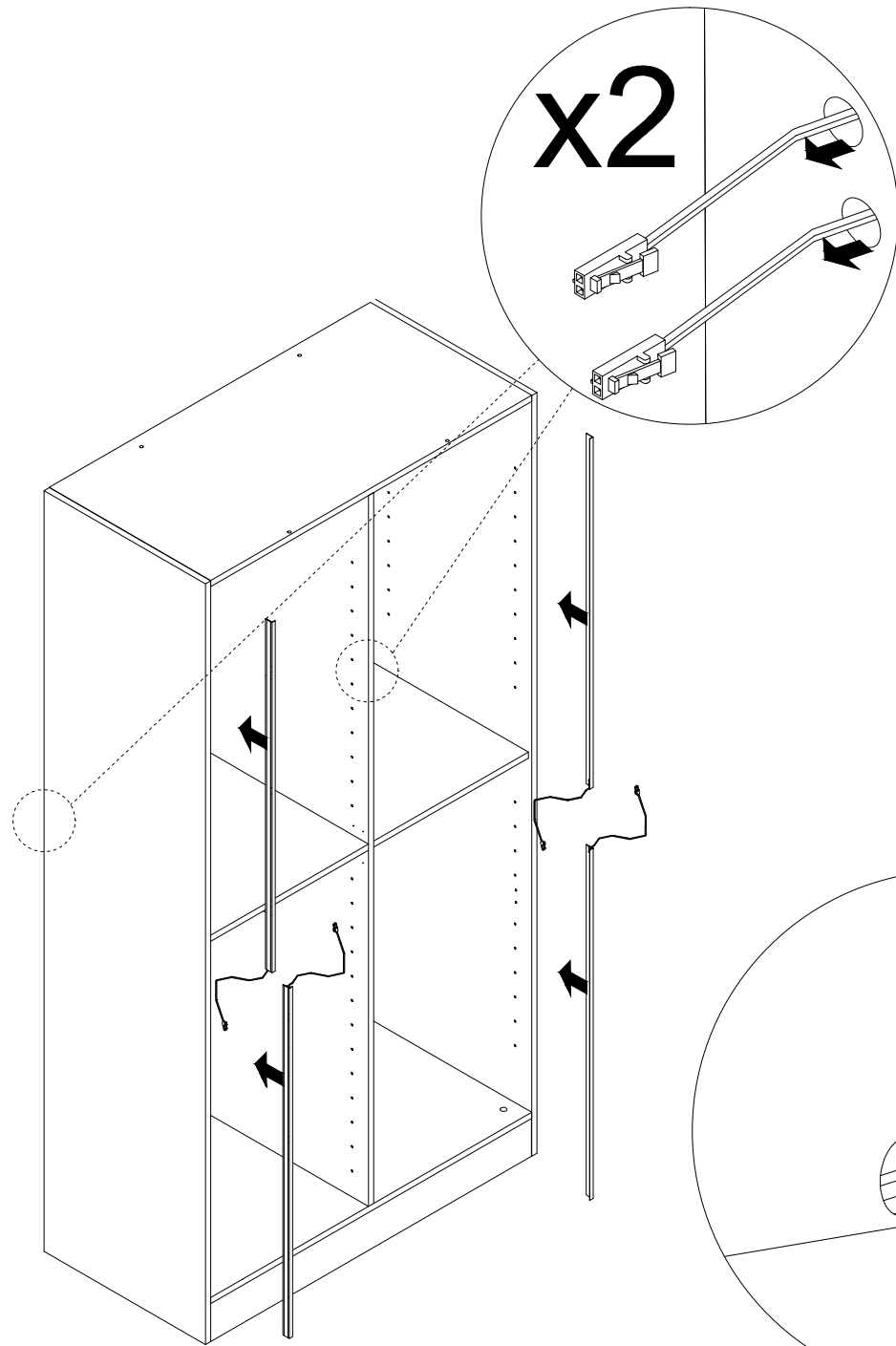
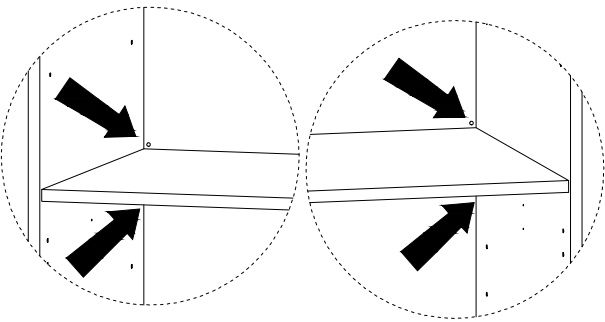
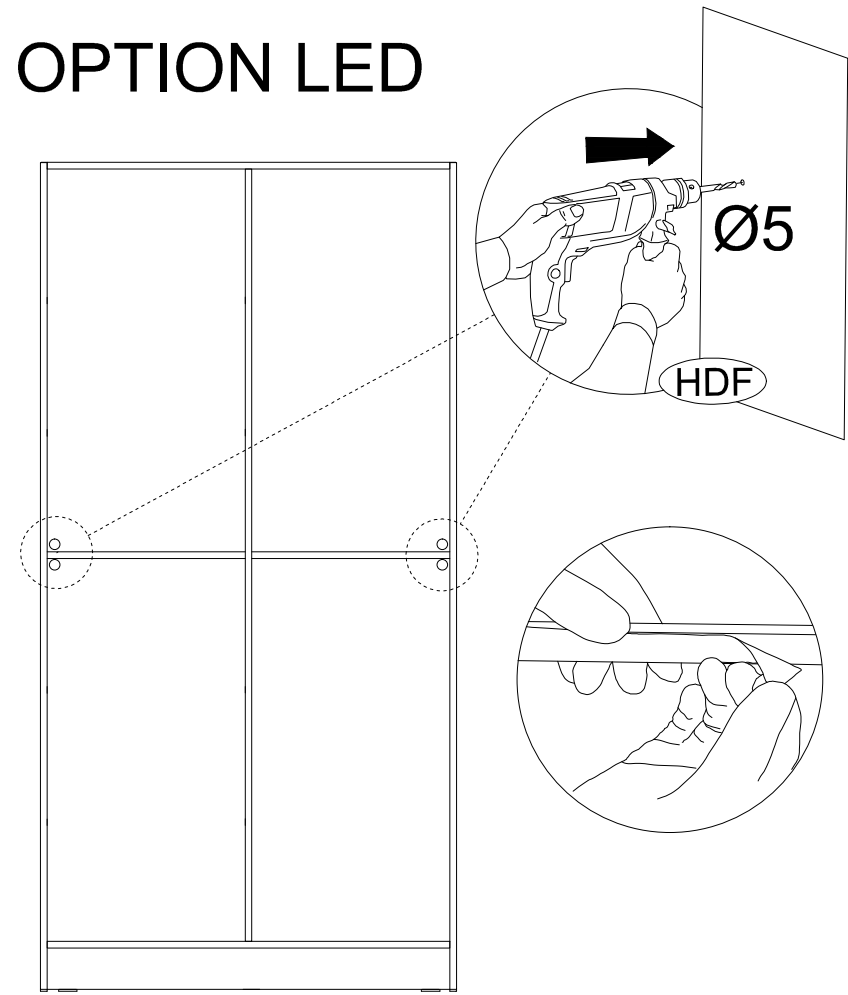

13

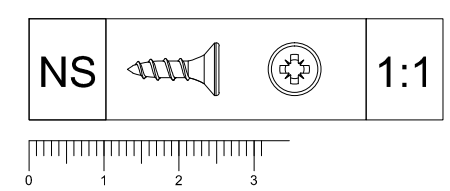
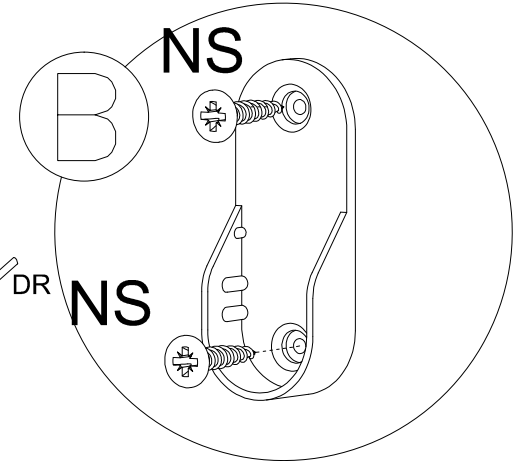
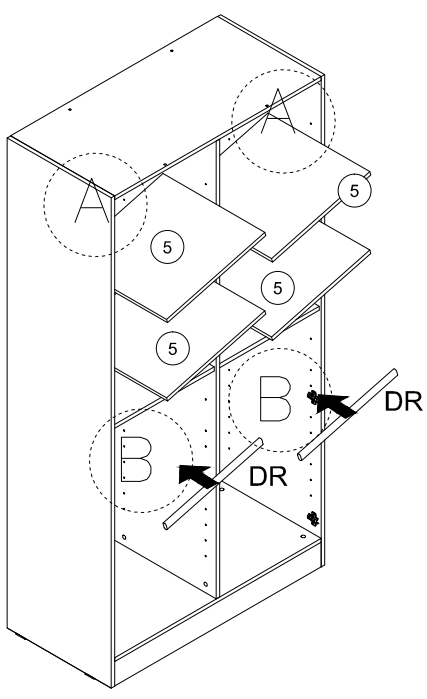
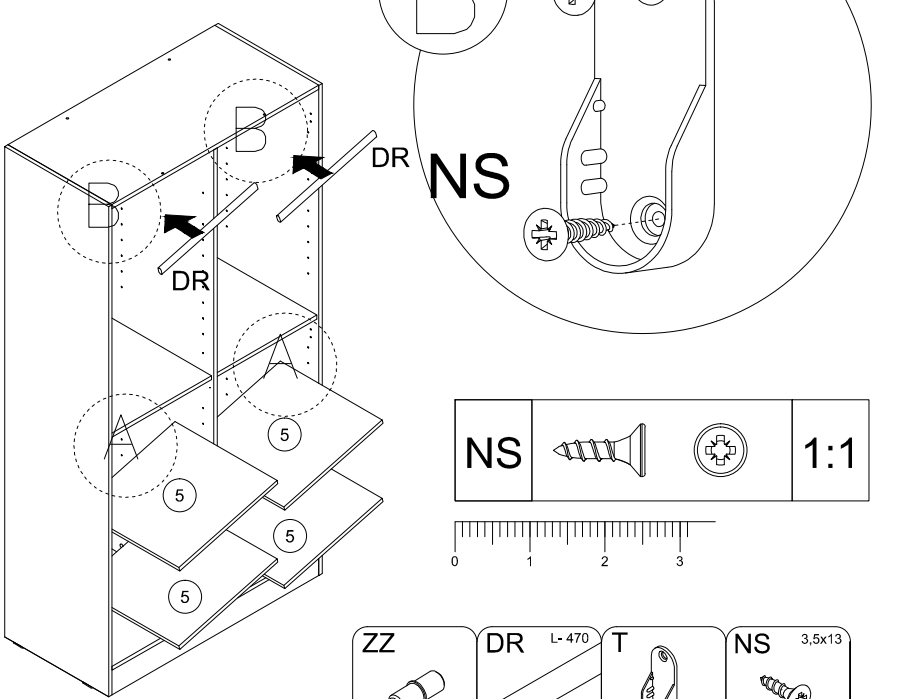
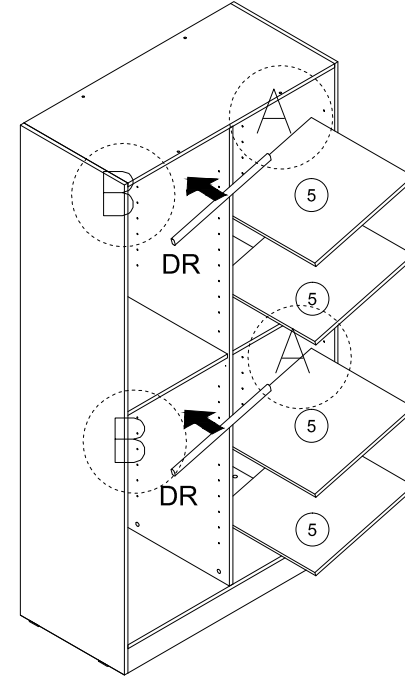
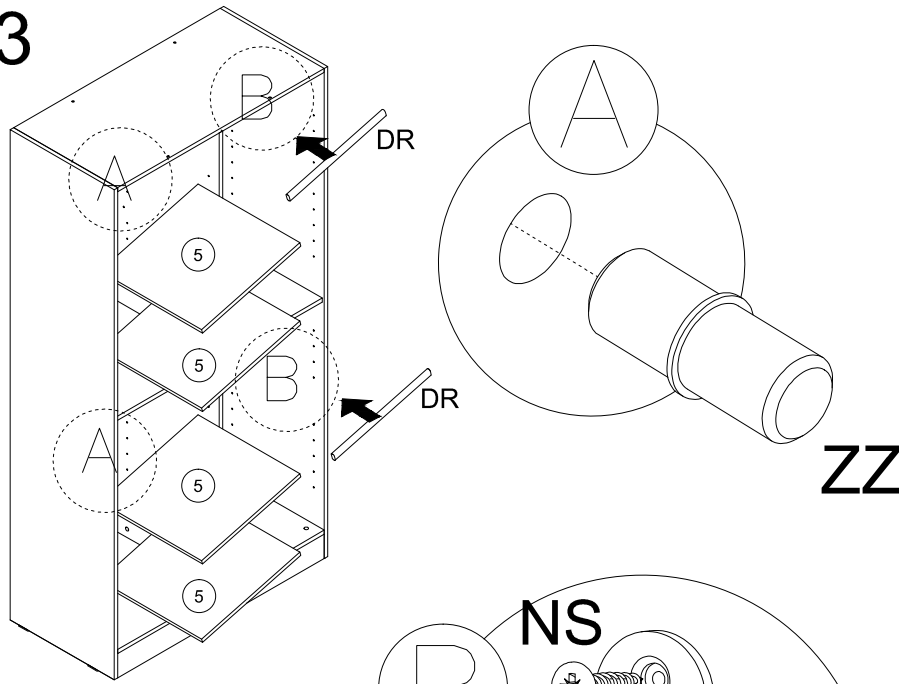

- ZZ

x16
- DR L-470

x2
- T

x4
- NS 3,5x13

x8

OPTION SHELF

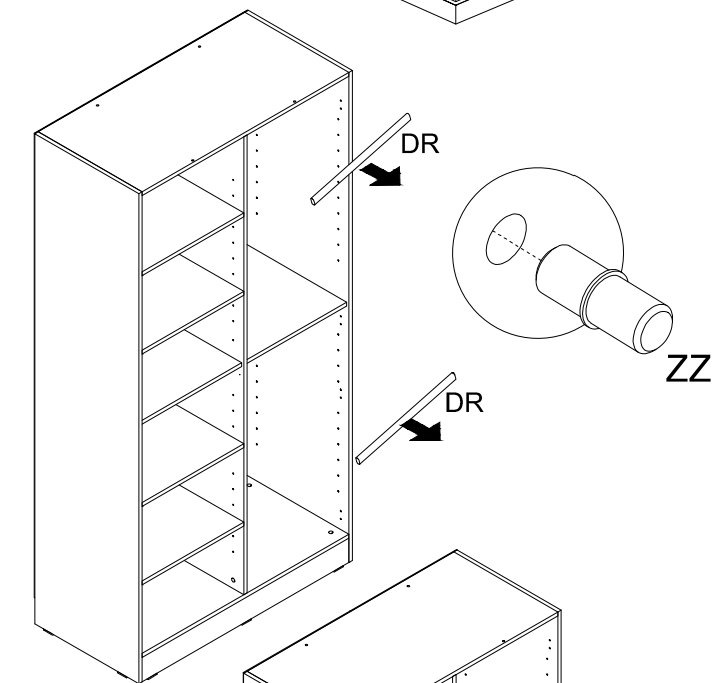
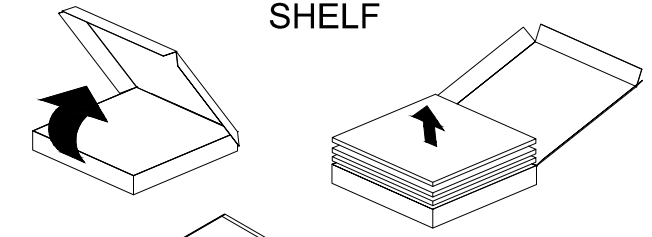



- ZZ OPTION

x16

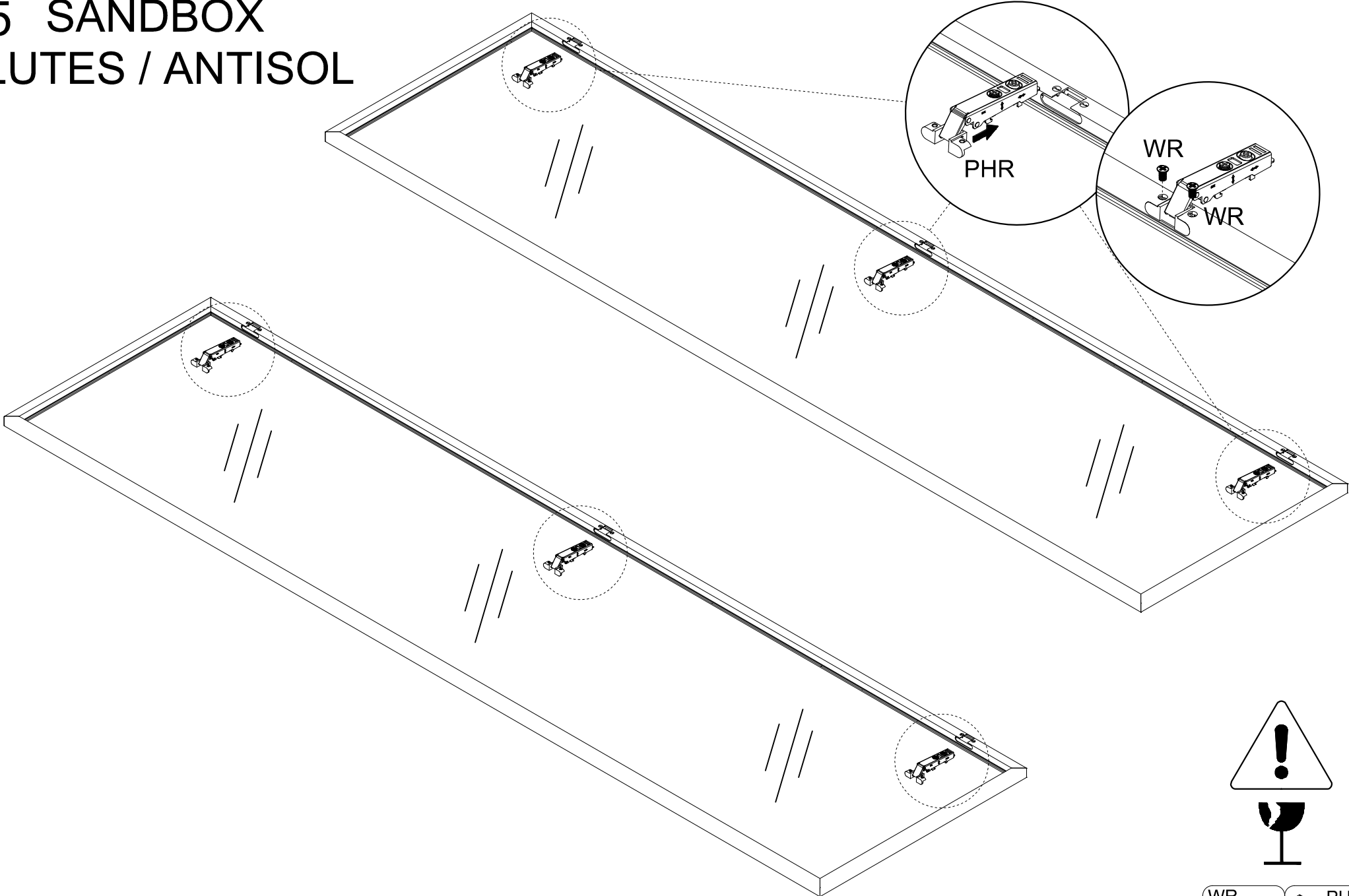

15 SANDBOX FLUTES / ANTISOL



WR  x12 ANTISOL / FLUTES	PHR  x6 ANTISOL / FLUTES
--	--

16 SANDBOX FLUTES / ANTISOL

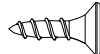
OPTION LED

NS			1:1
----	---	---	-----

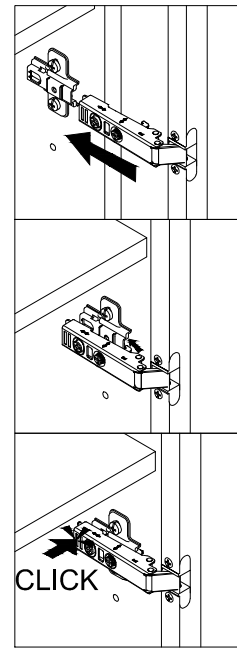
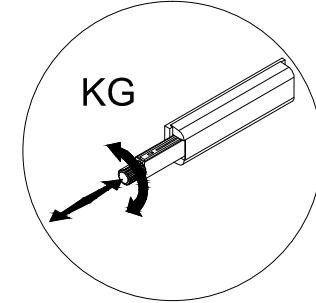
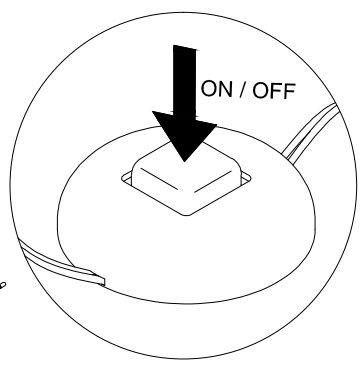
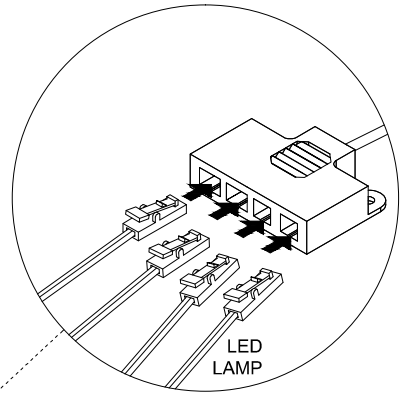
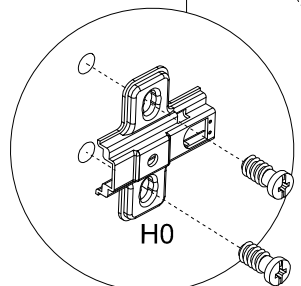
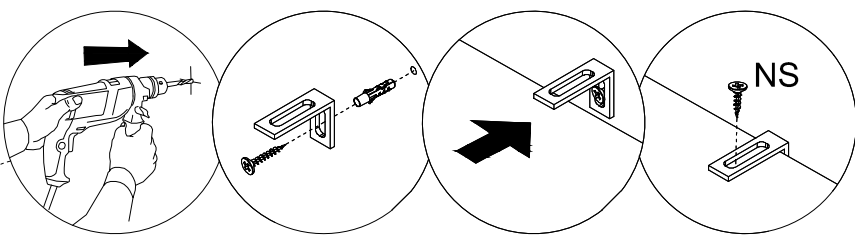
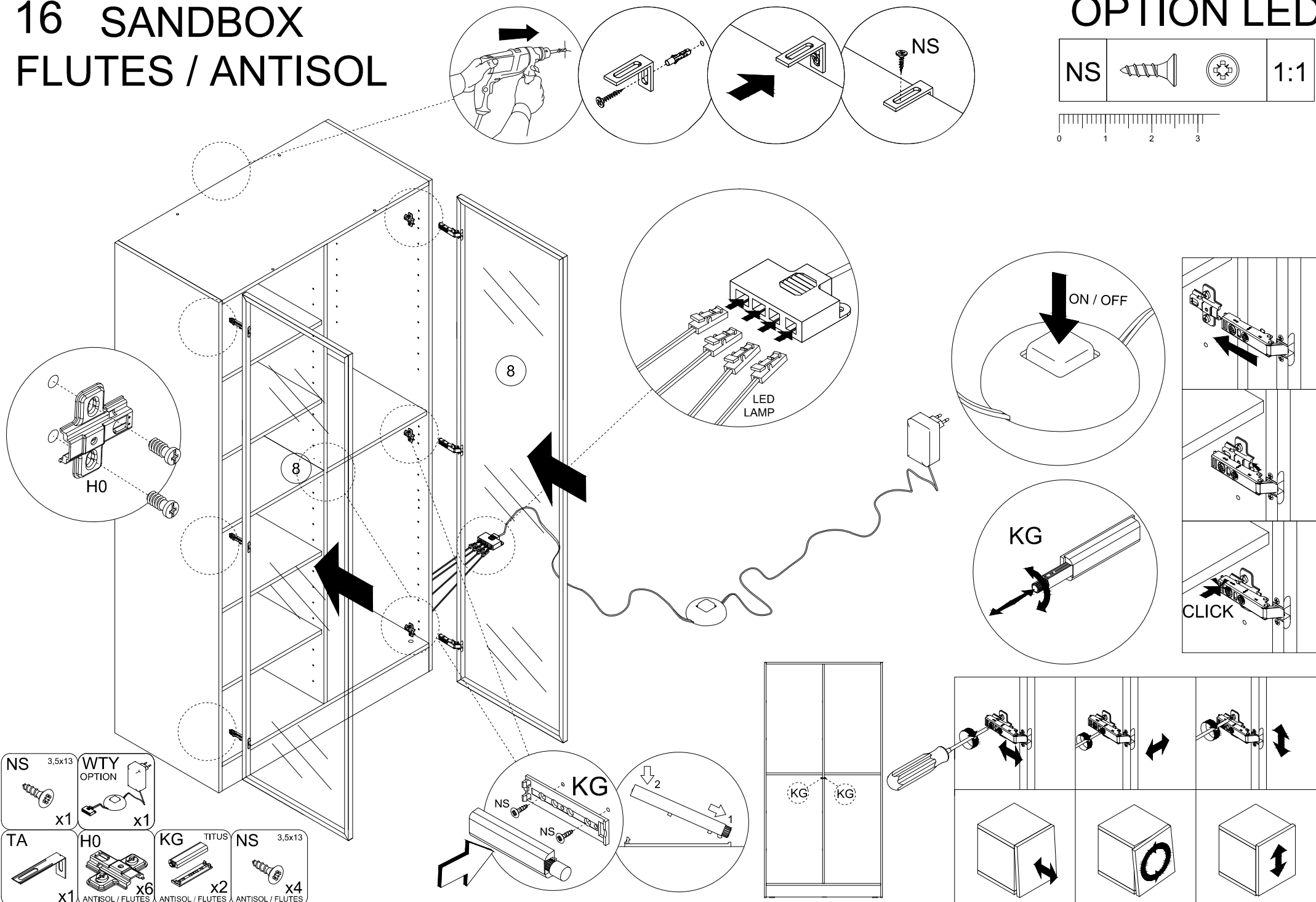

NS 3,5x13 x1	WTY OPTION x1	KG TITUS x2	NS 3,5x13 x4
TA x1	H0 ANTISOL / FLUTES x6	NS 3,5x13 x4	

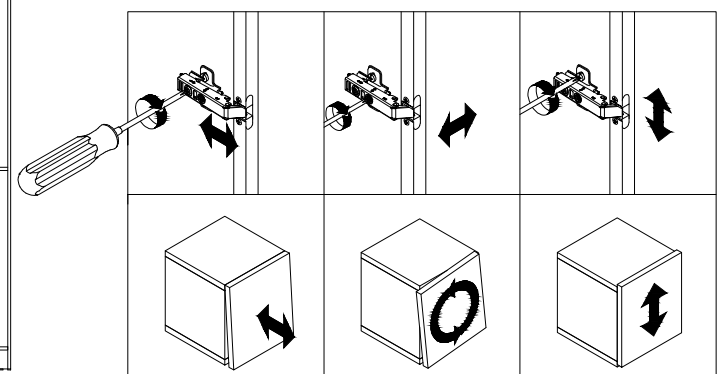
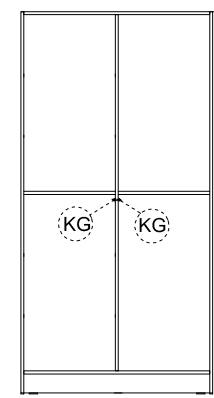
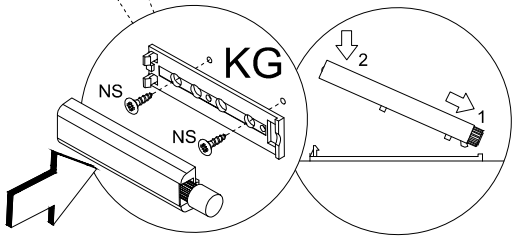

17

OPTION

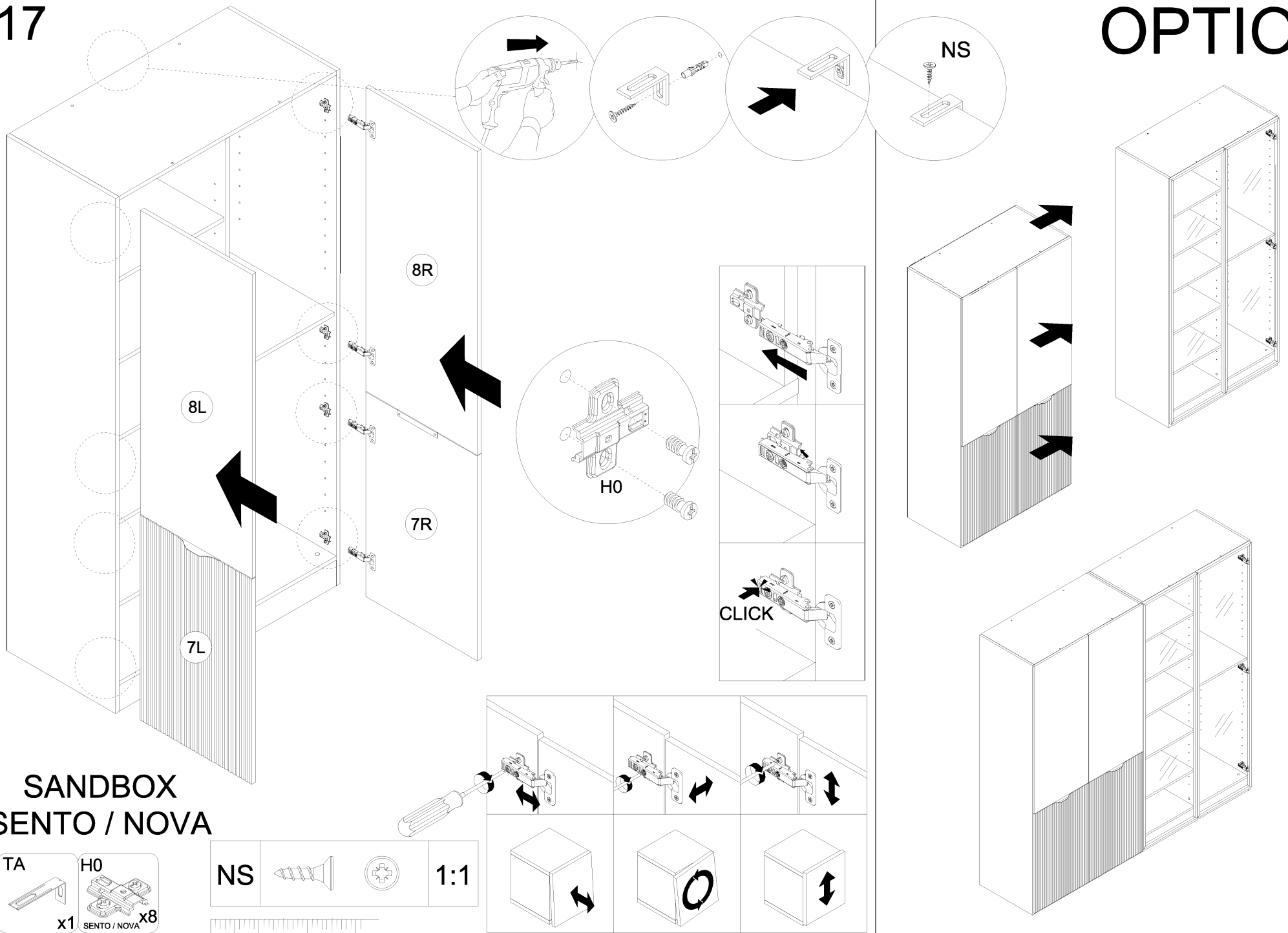

SANDBOX
SENTO / NOVA

TA H0

 x1 x8
 SENTO / NOVA

NS 1:1

