

Metal Storage Cabinet Instruction Manual

Your new Metal Storage Cabinet has arrived and it will make your life so much easier. That's why we put so much effort into designing it to perfectly fit your needs.

But first things first, we need to install it!
When we say 'we', we mean we're going to guide you, step by step.

We created this instructions manual so that you won't feel overwhelmed and We also know that sometimes things just don't seem to fit, so don't hesitate to contact with our Amazon Customer Associate if you have questions or need help!

Missing A PART? DON' T WORRY, WE GOT YOUR BACK!

Compare the sketch on the next page with your package. Are all the pieces there? However, sometimes error happen, so if anything is missing or damage, just send us an email and we will make sure to fix it!

If you find scratches on the sides of the product after you open the package.
DON' T WORRY, this is the protection of express packages.

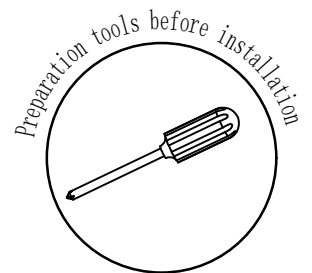
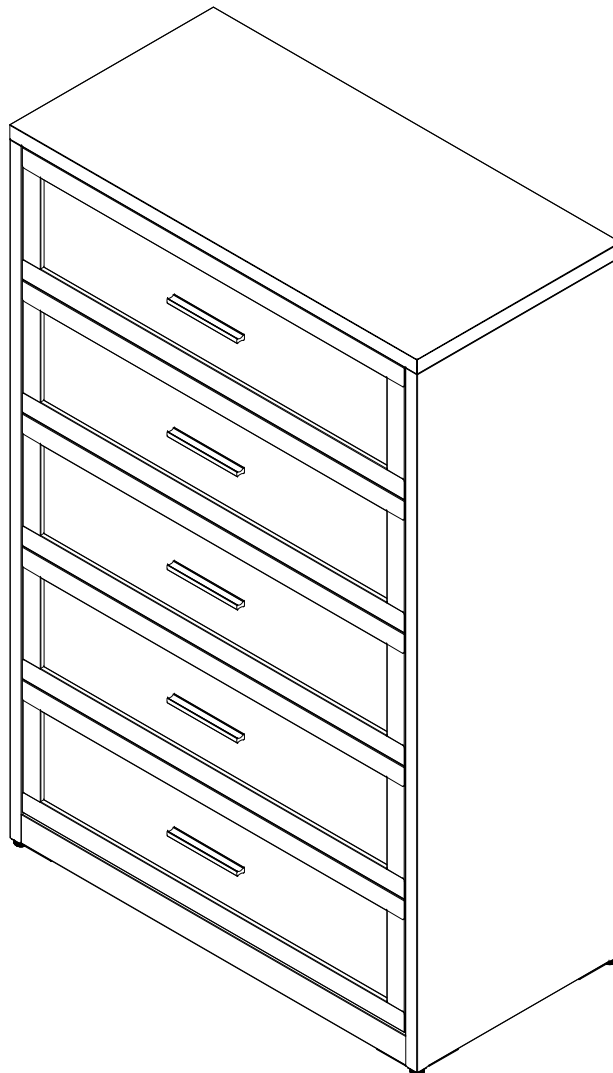

A*1

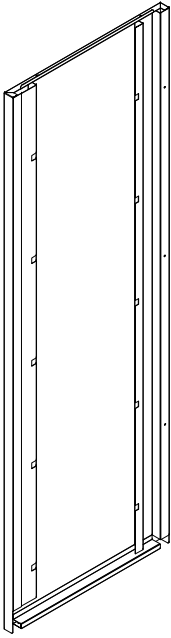

B*1

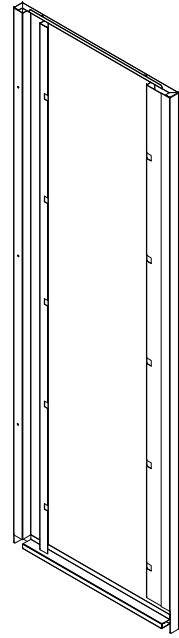

C*2

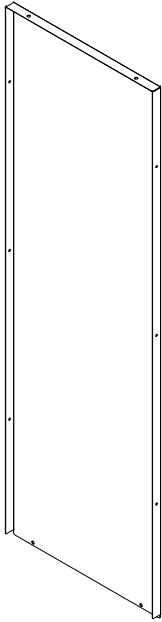

E*1

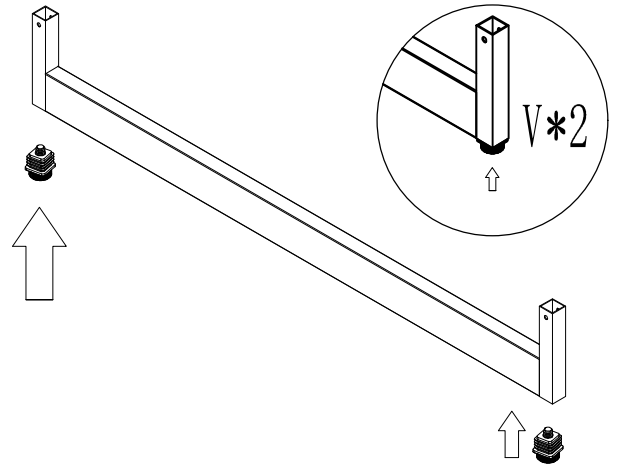

G*4

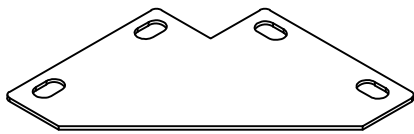

H*1

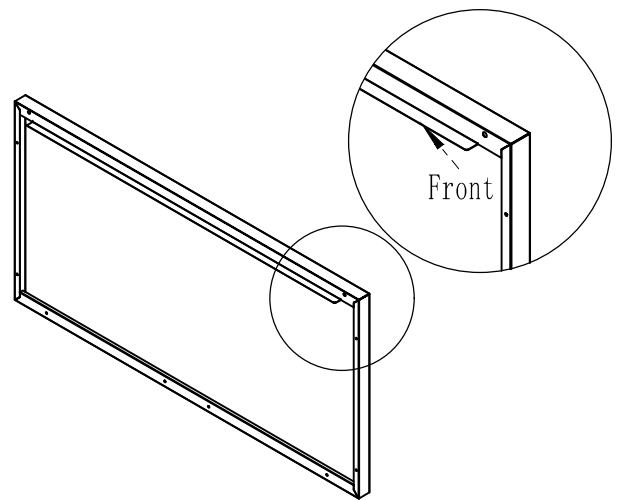

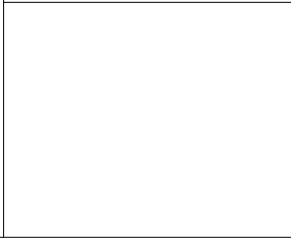
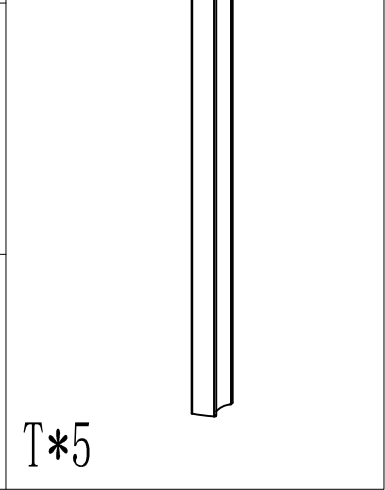
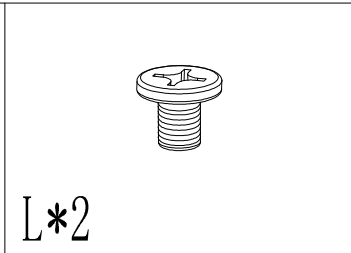
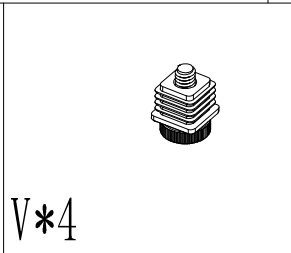
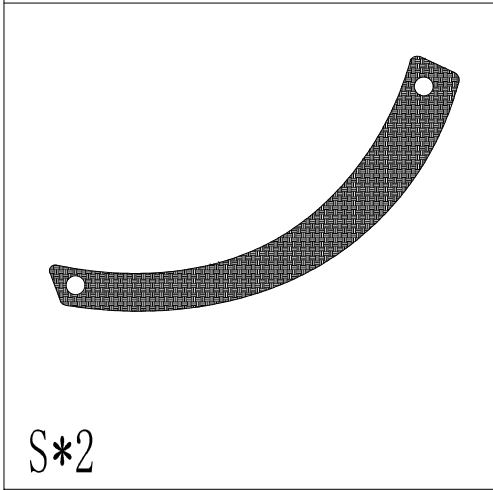
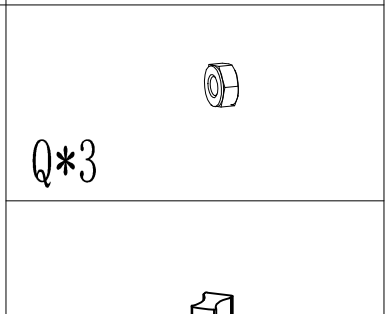
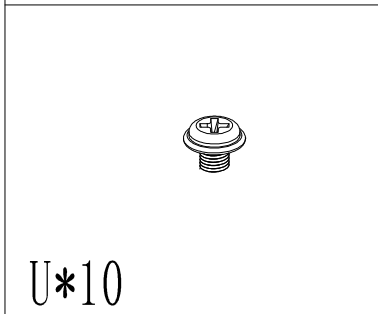
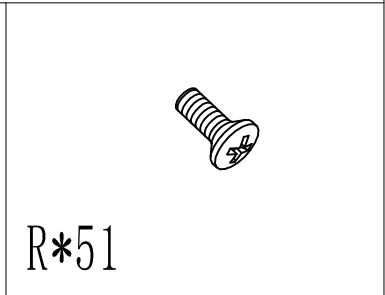
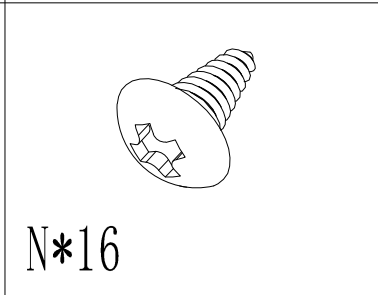
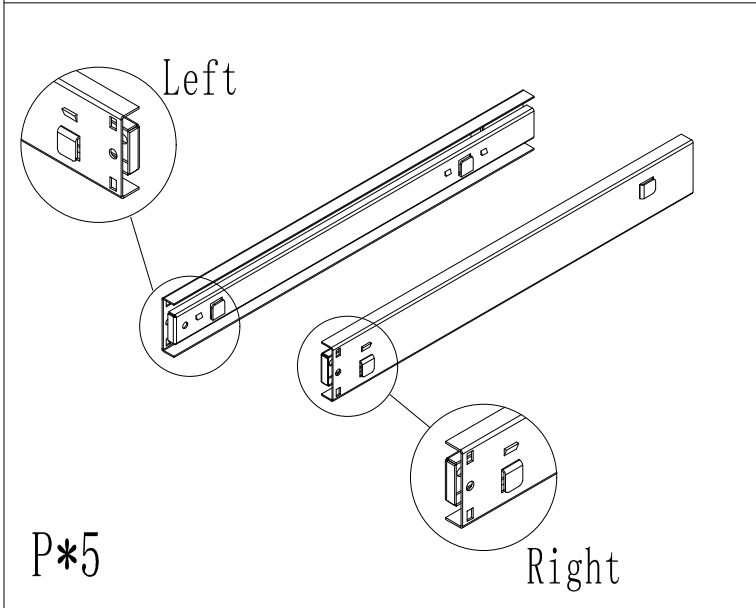
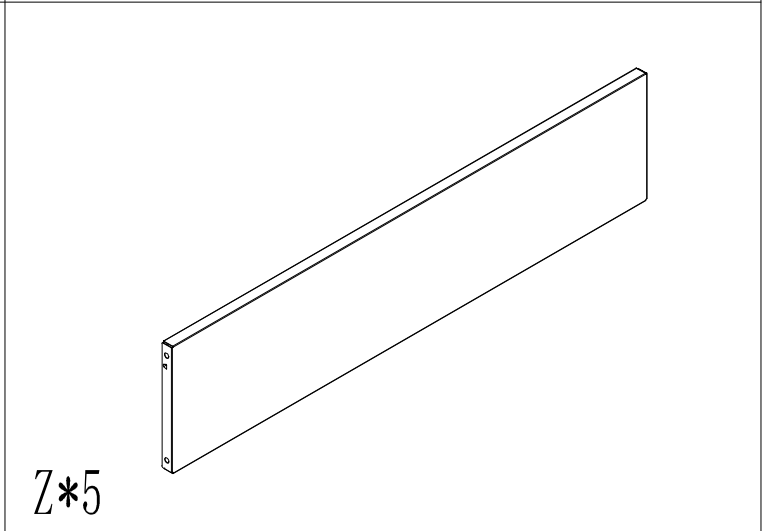
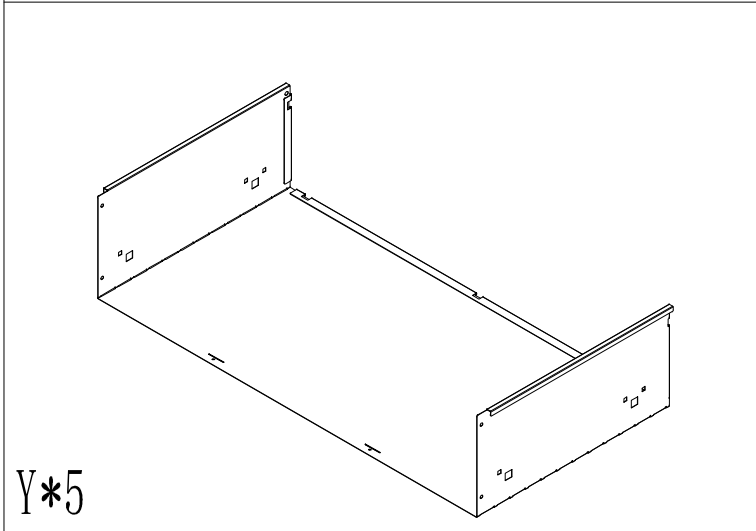
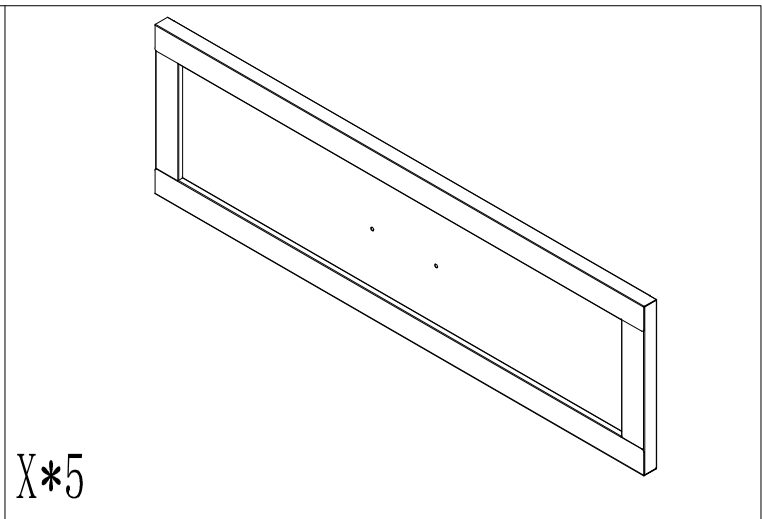
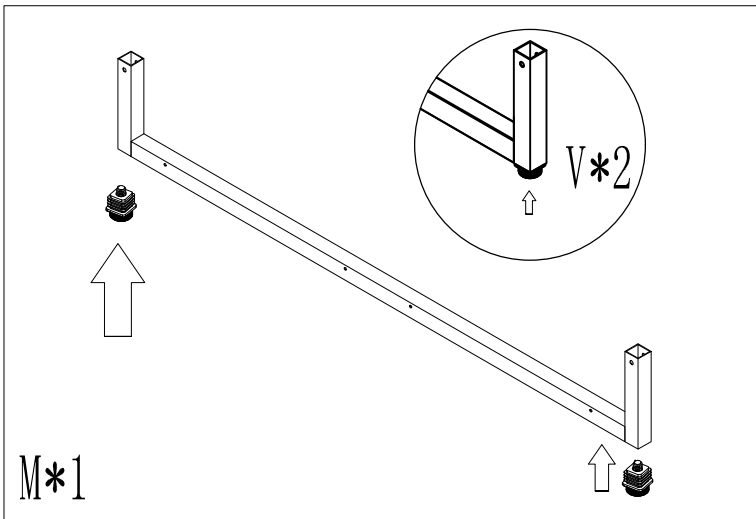

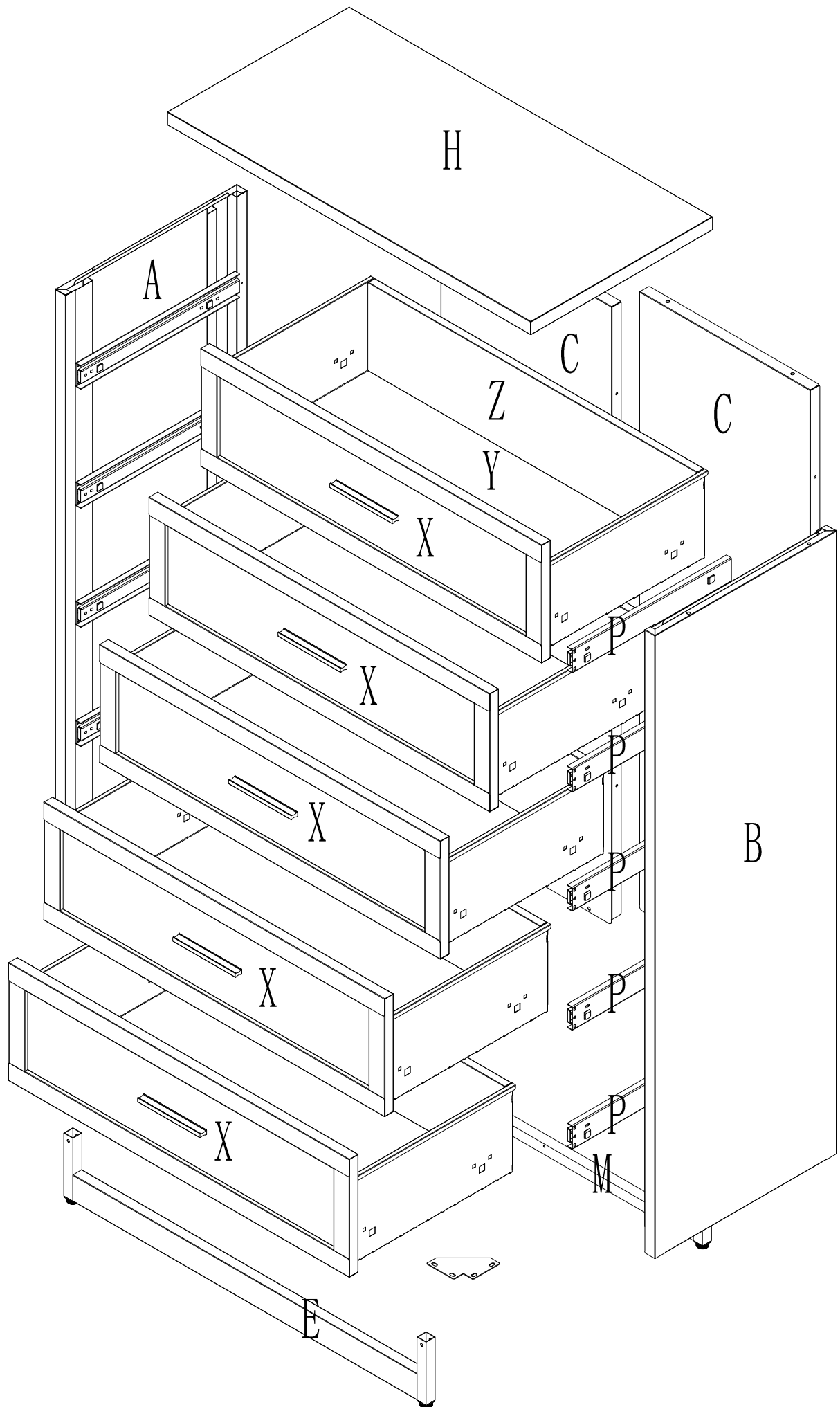

1

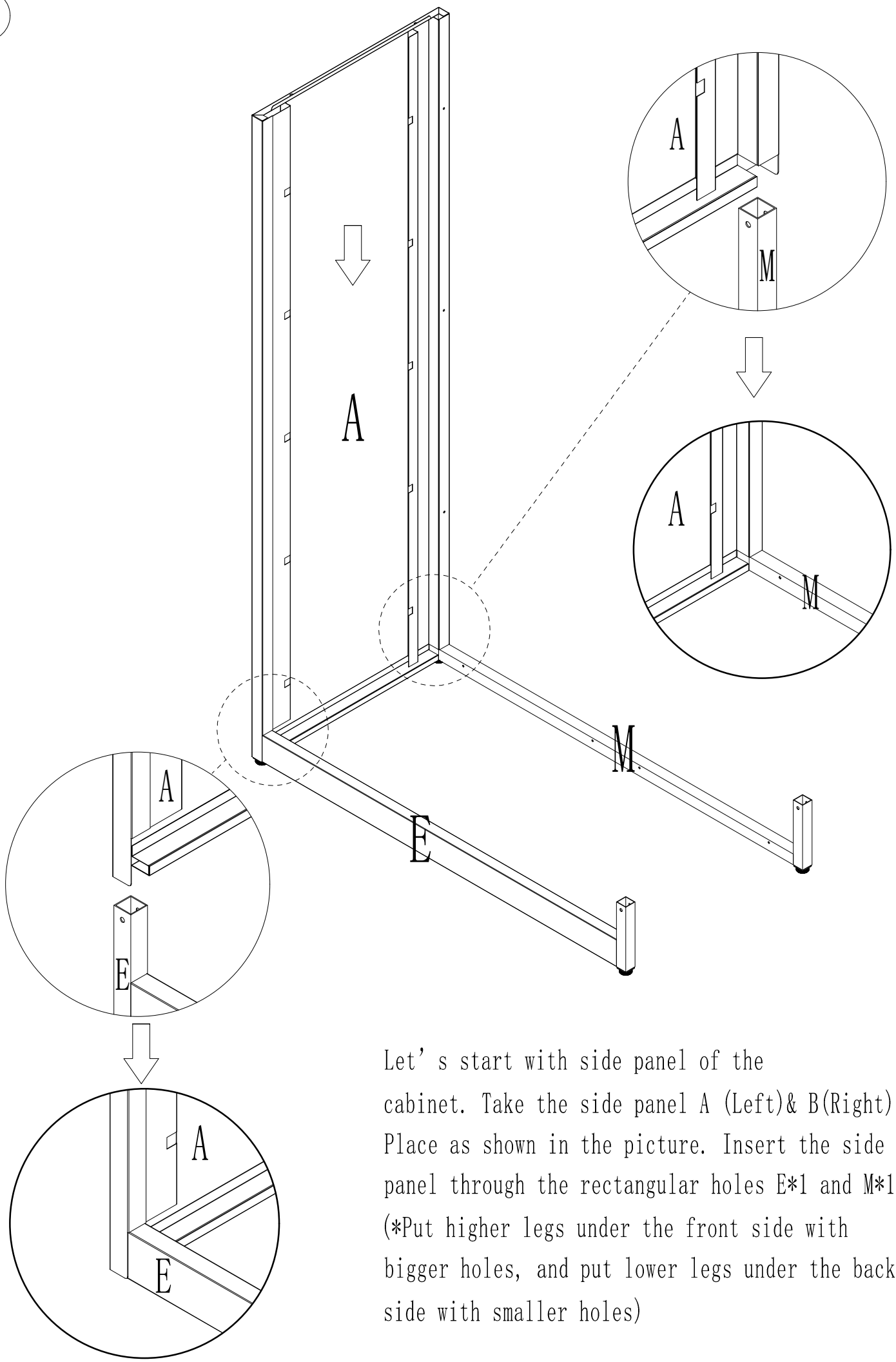

Let's start with side panel of the cabinet. Take the side panel A (Left)& B(Right). Place as shown in the picture. Insert the side panel through the rectangular holes E*1 and M*1. (*Put higher legs under the front side with bigger holes, and put lower legs under the back side with smaller holes)

2

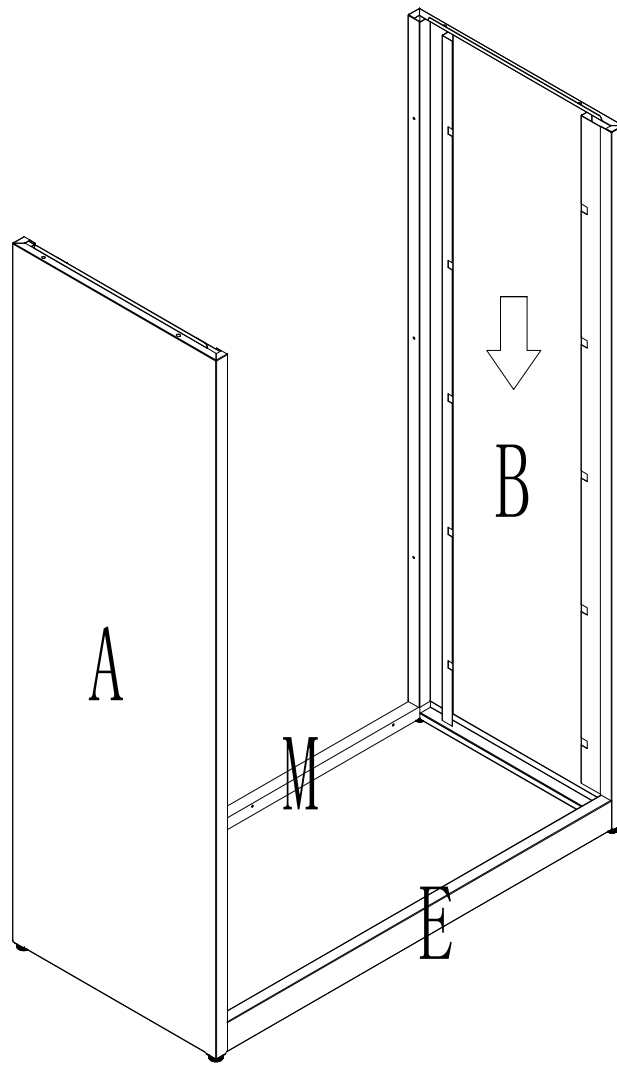

3

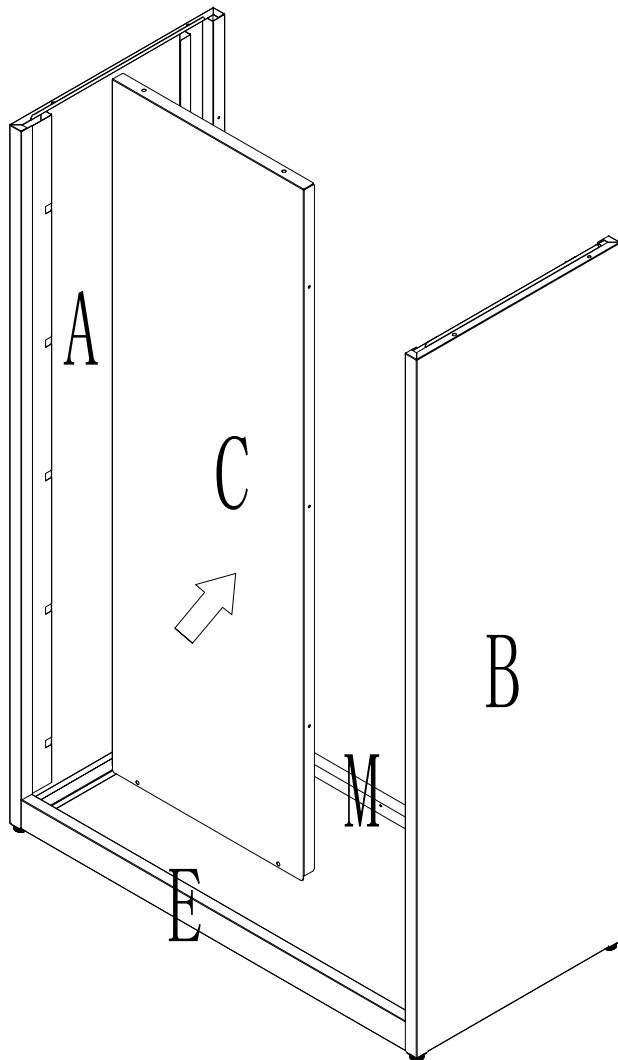

Take Back Panel C1 & C2.

(*Concave side of back panel(part C) must face toward outside)

The frame with round holes must be pointing upwards.

Overlap & align the holes of the interior frames.

Fasten in place using 13R & 3Q screws.

3*R screws on the left side & 3*R screws on the right side.

3*R and 3*Q in the middle. Make sure the last 4*R screws installed in the bottom from the inside. (show in the picture).

4

R*5 

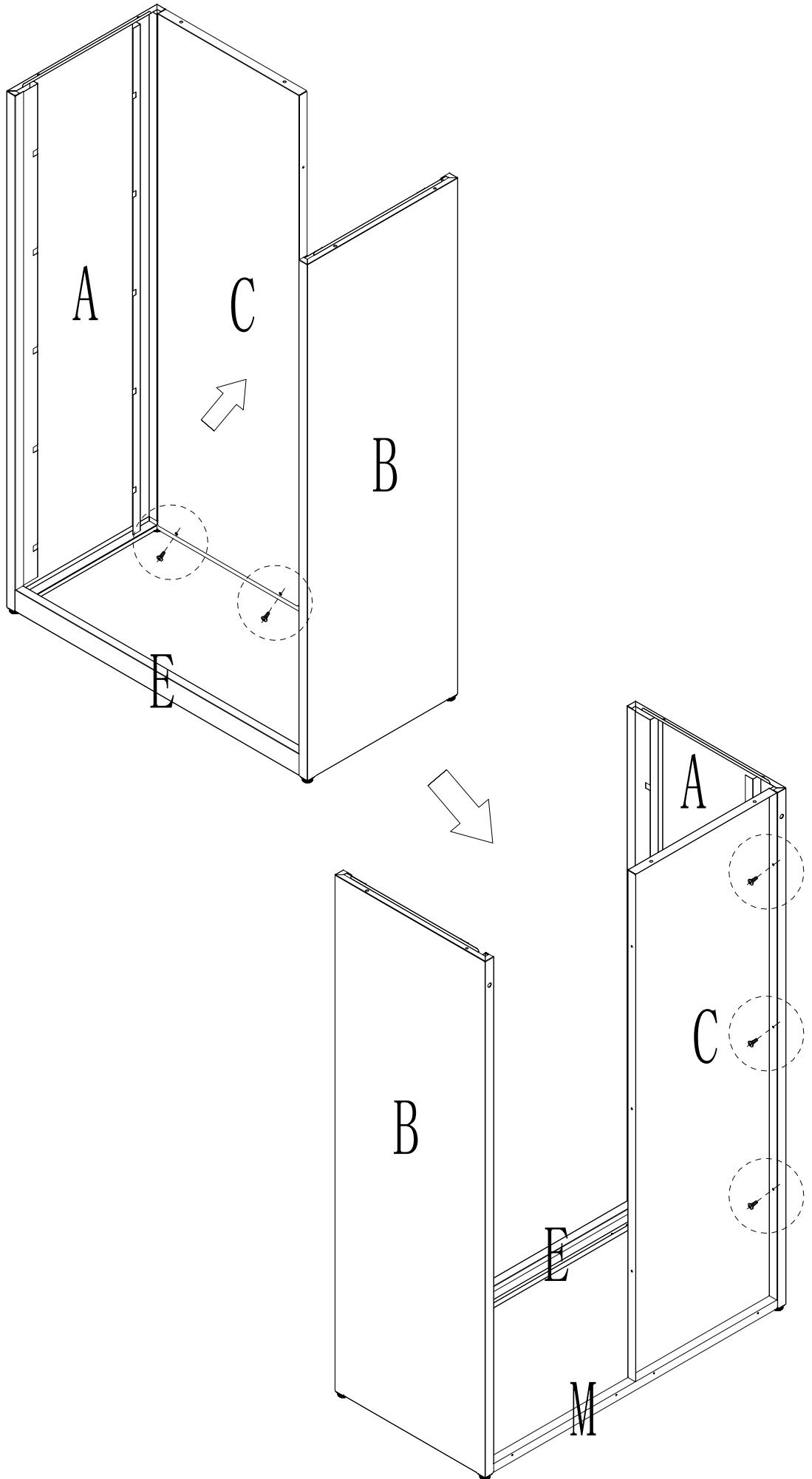

5

R*8 

Q*3 

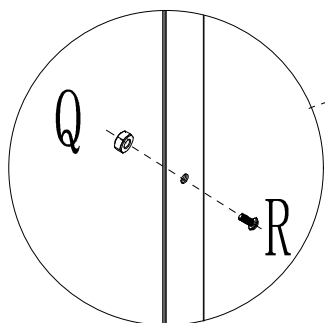
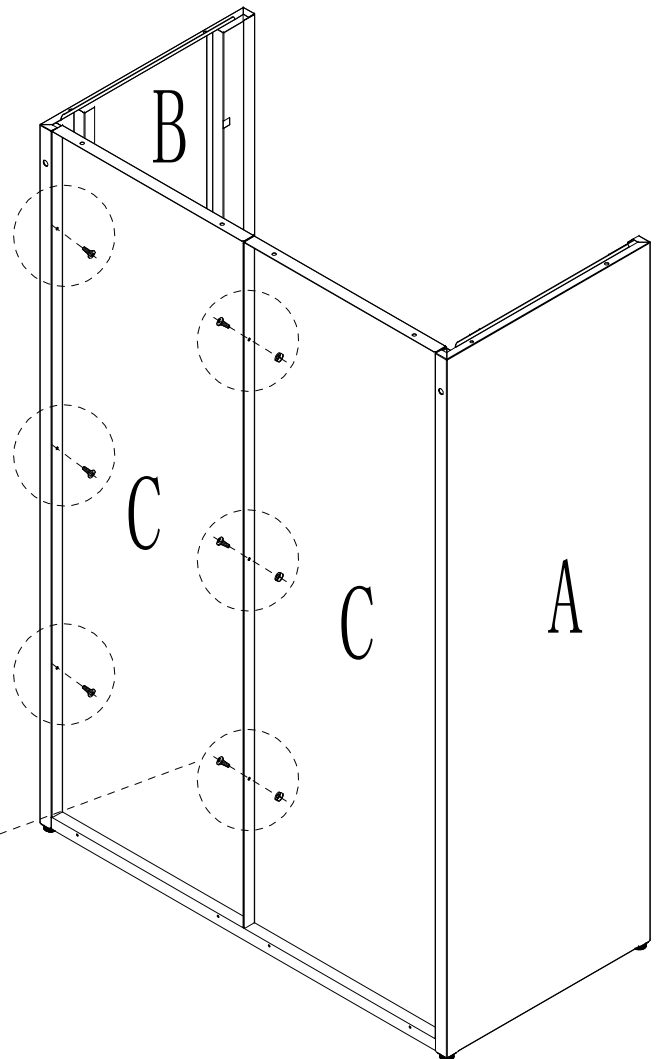
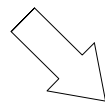
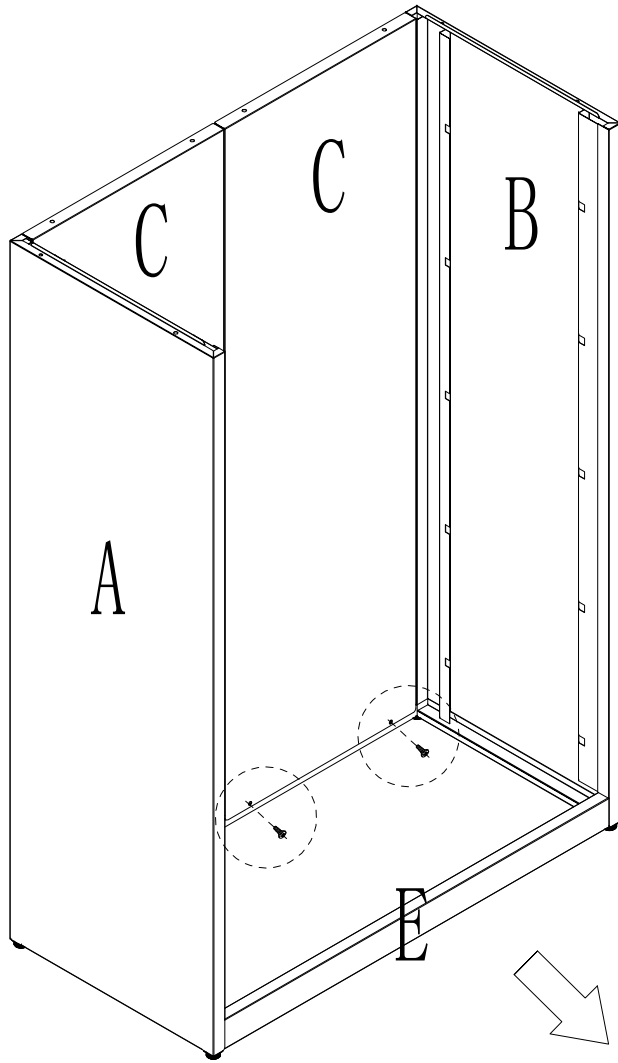

6

R*8 

Take Top Frame H*1 (*the side with fence stay in the same direction of the drawers)
Fasten in place using 8*R screws through the holes in each corner. Insert it through cabinet ,Push it until well fixed.

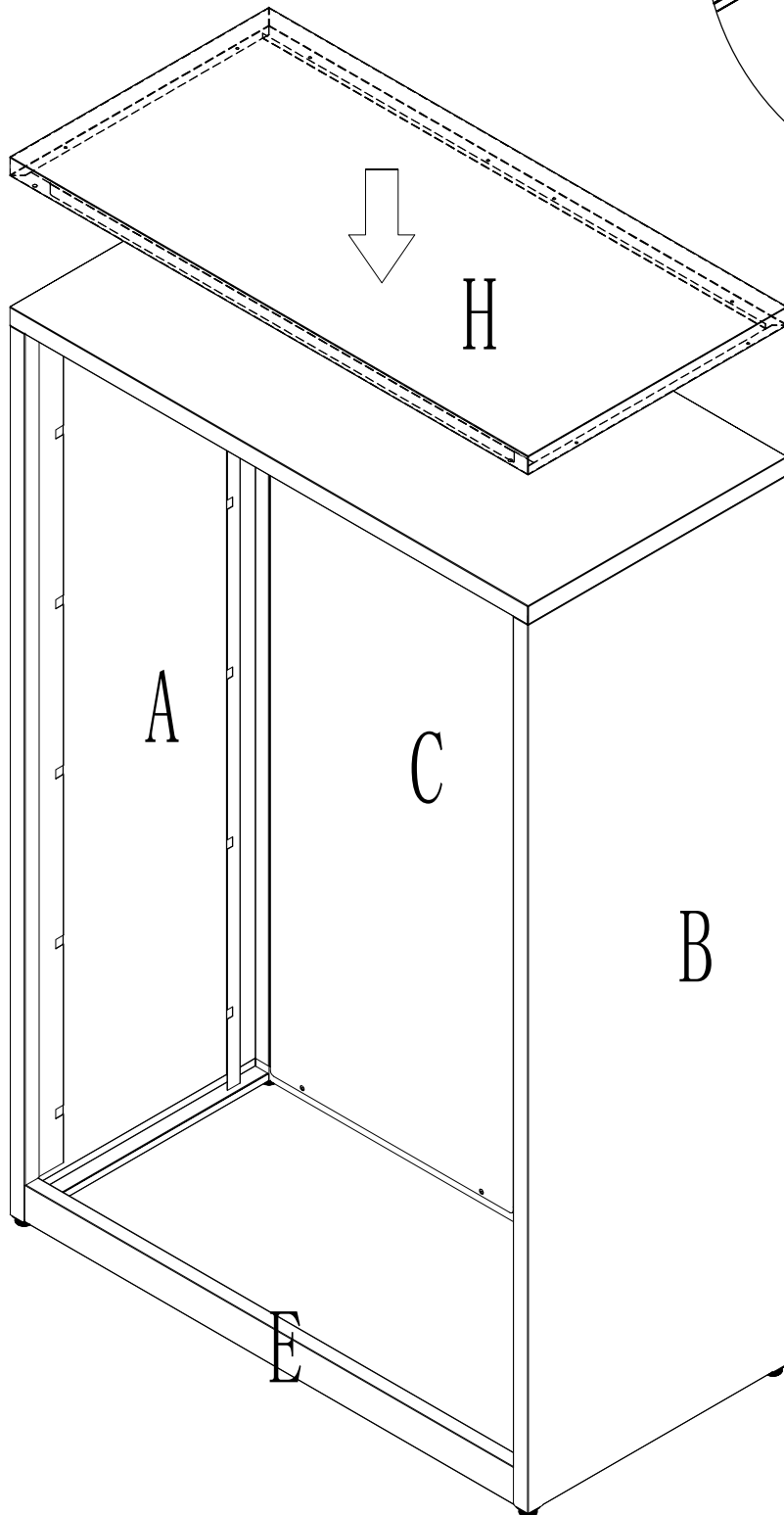
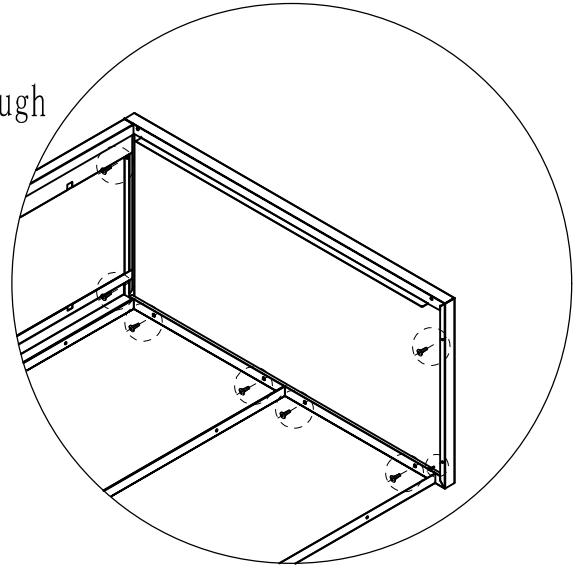

7

N*16 

G*4 

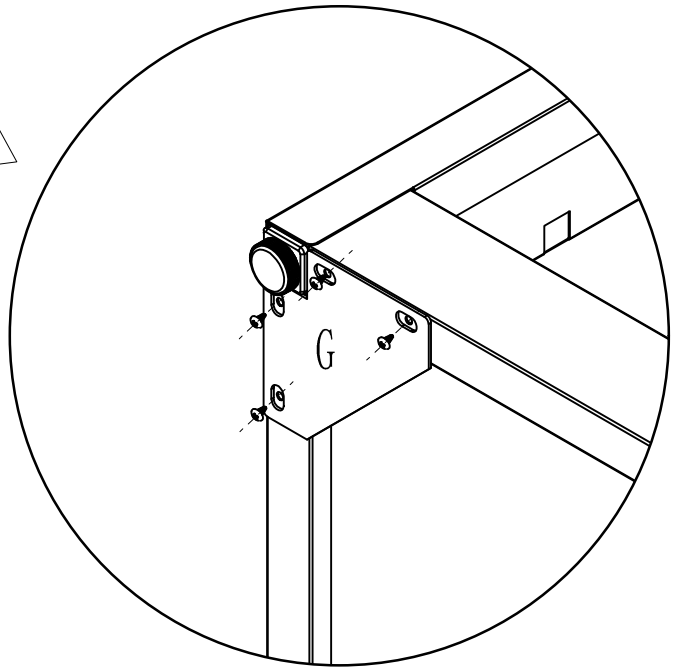
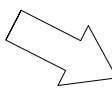
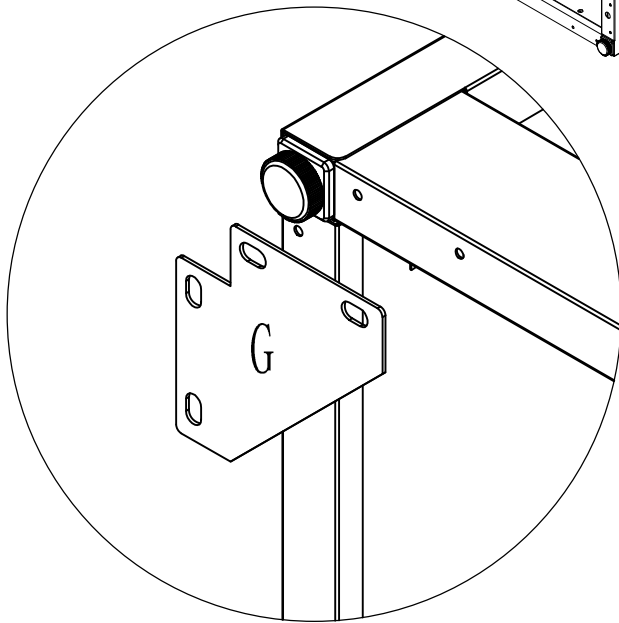
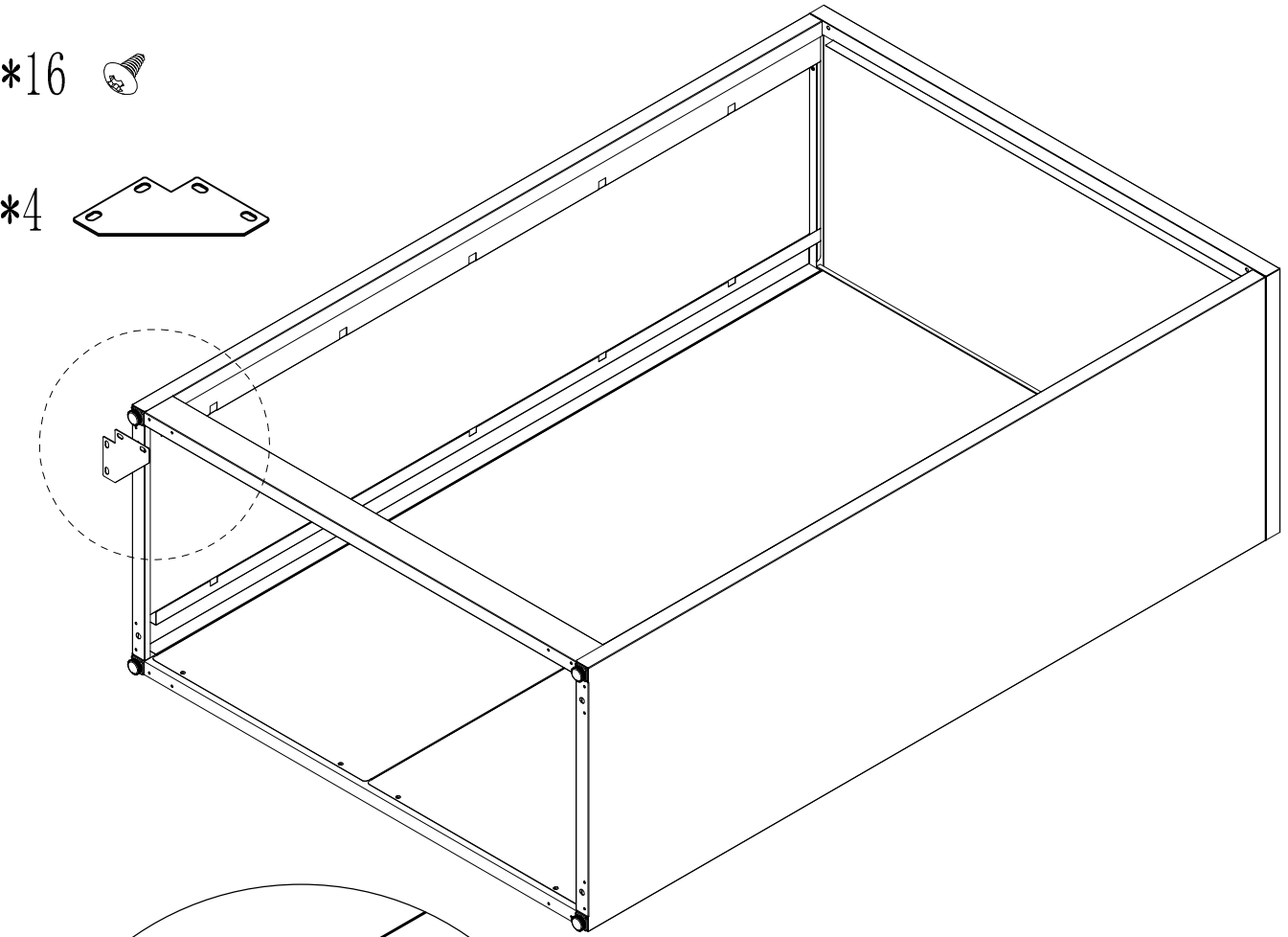

Bring the cabinet down, Take secure component 4*G put at the bottom of cabinet. Fasten in place using 16*N screws through the holes in each corner. Take screws 4*V place through the holes in the bottom of E*1 and M*1.

8

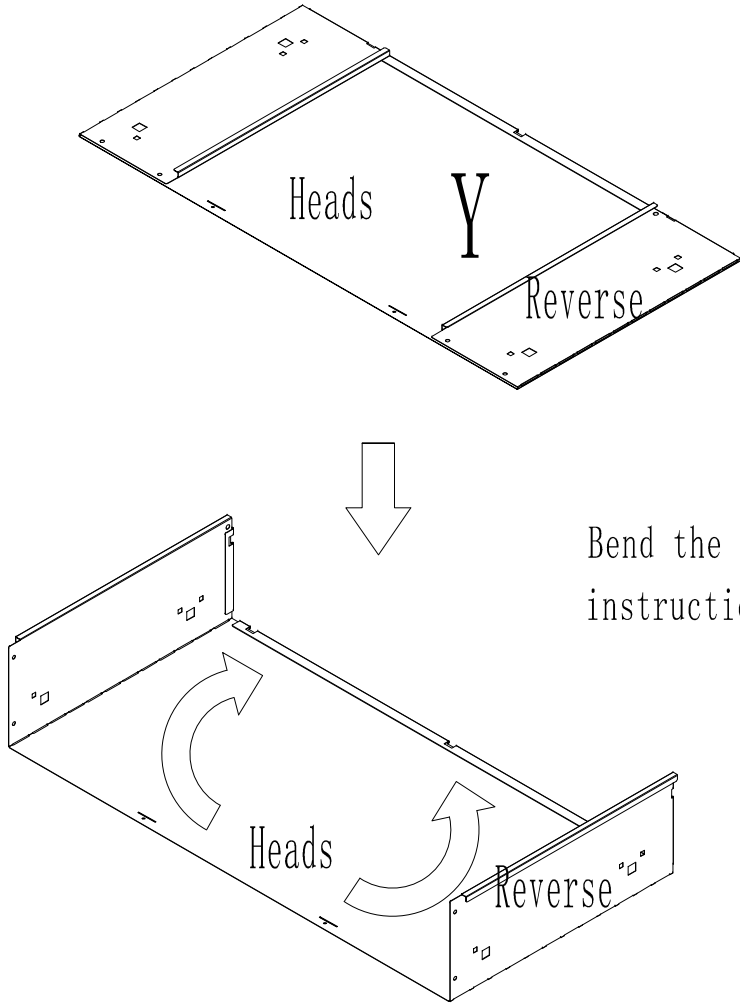

Bend the drawer box Y as the instruction shown.

9

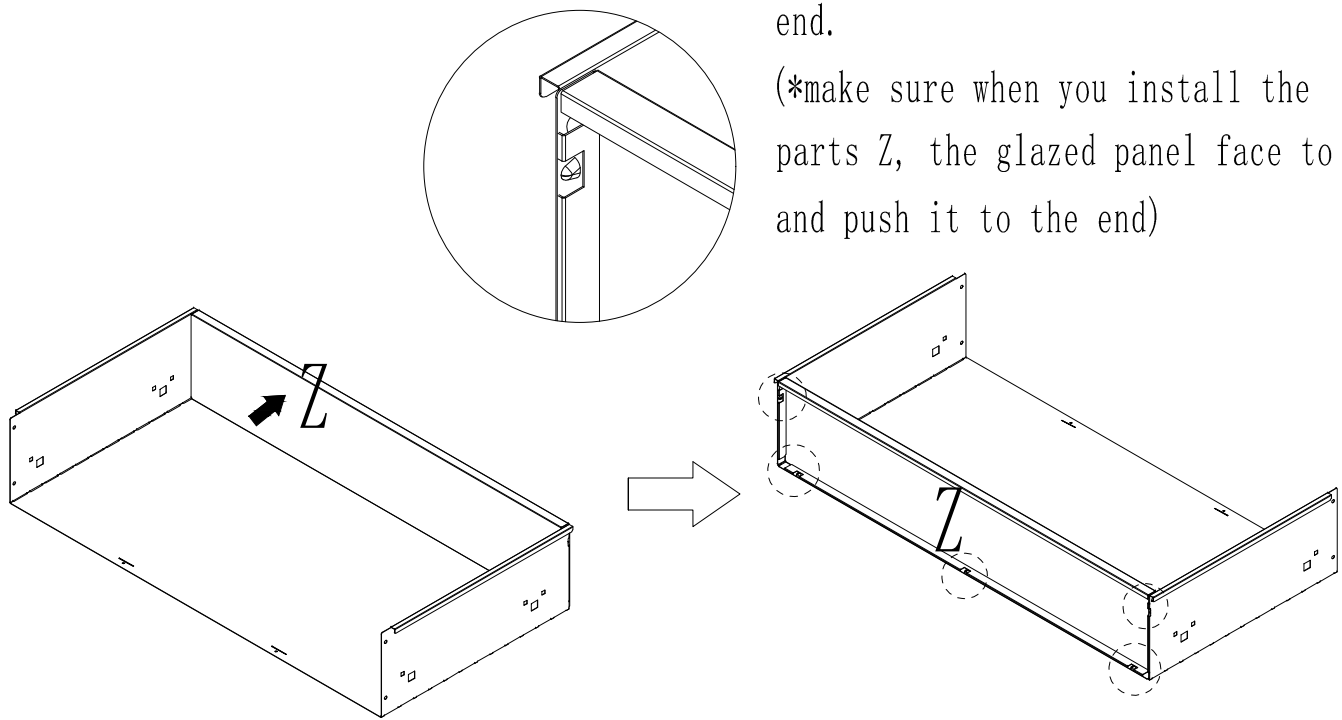

Take parts Z, insert the middle of F and push the back drawer seal to the end.

(*make sure when you install the parts Z, the glazed panel face to you and push it to the end)

10

R*30 

Install the parts X by using 6*R screws, Follow this process to complete the rest Four drawers.

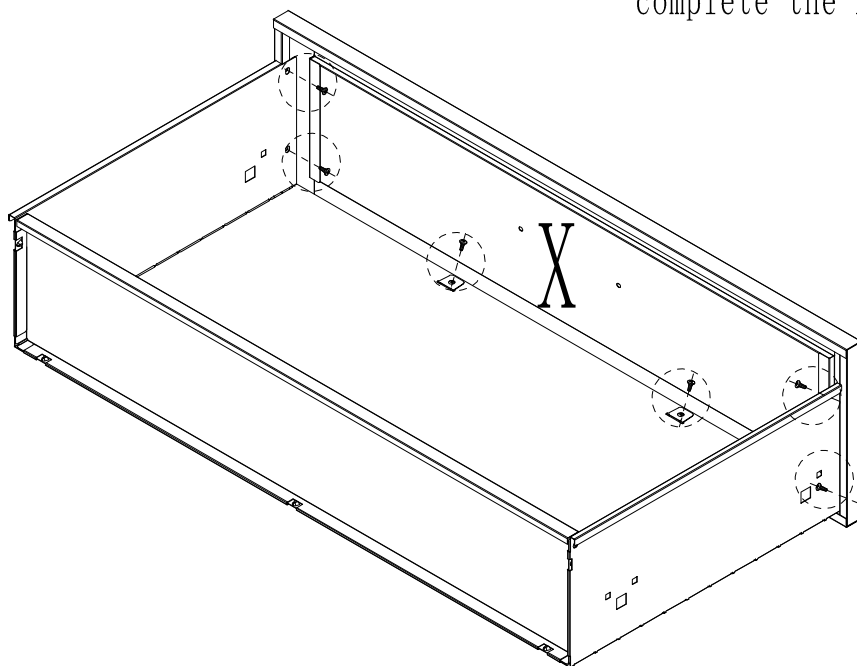

11

T*5 

U*10 

Install the Four drawers handle 5*T by using 10*U screws.

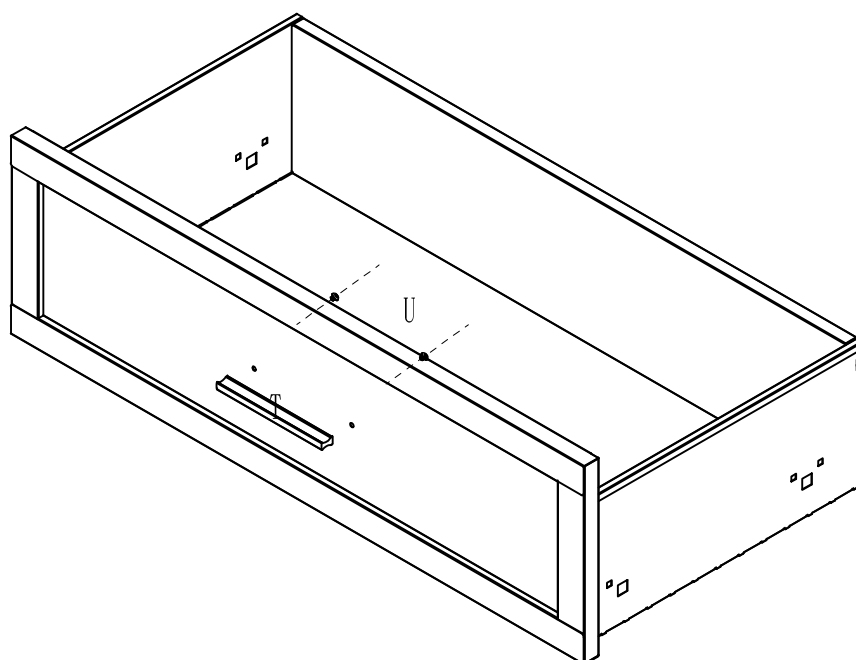

12

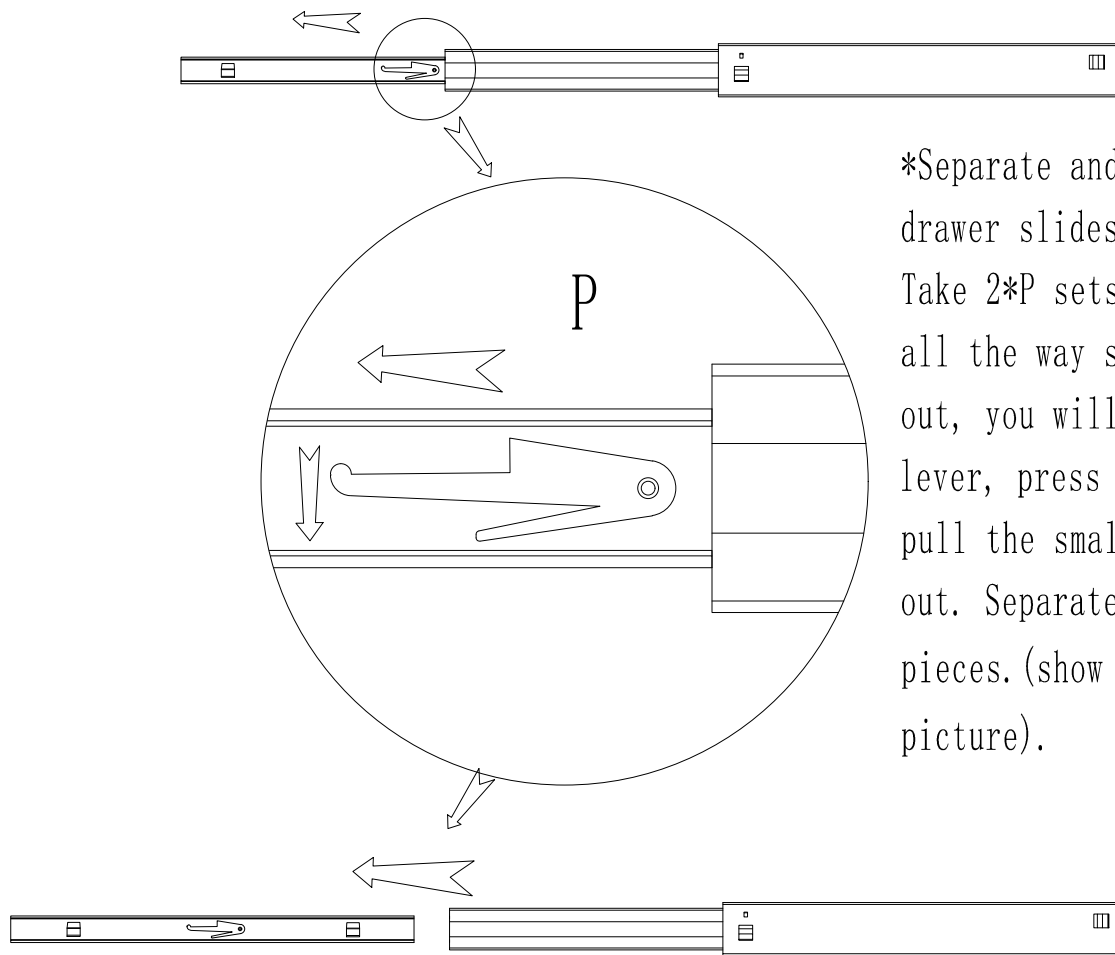

*Separate and install drawer slides
Take 2*P sets of rail, pull all the way slide rail out, you will see the lever, press it down, then pull the small inner rail out. Separate in two pieces. (show in the picture).

13

Install the drawer side of the slide, you will see there is rectangular hole on the said of the drawer, then install drawer side of slide onto both said of the drawer panel.
Same process to complete the rest of 2 drawers.

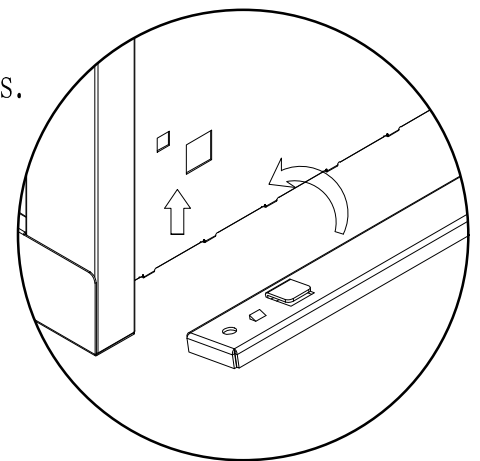
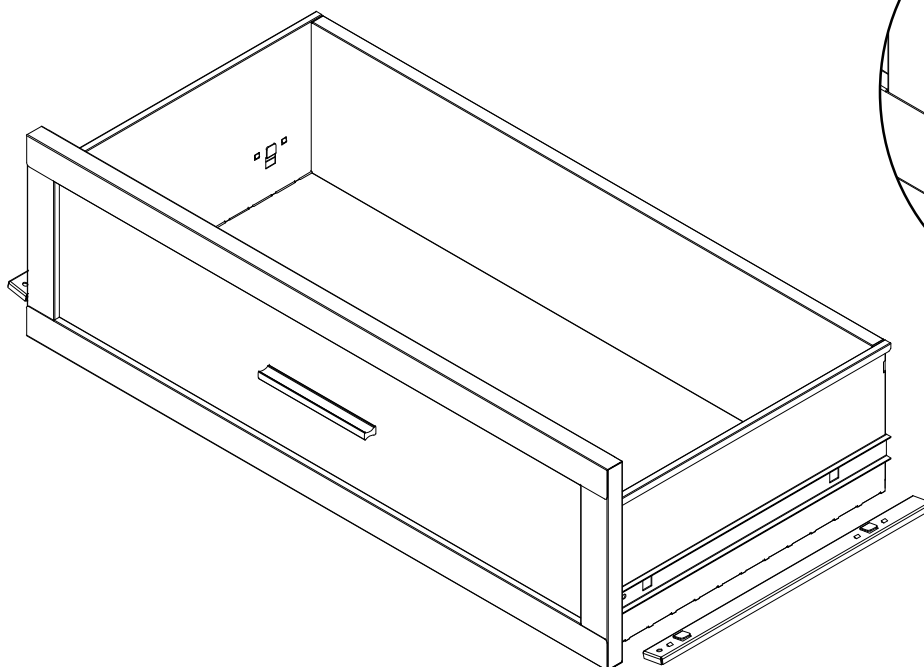

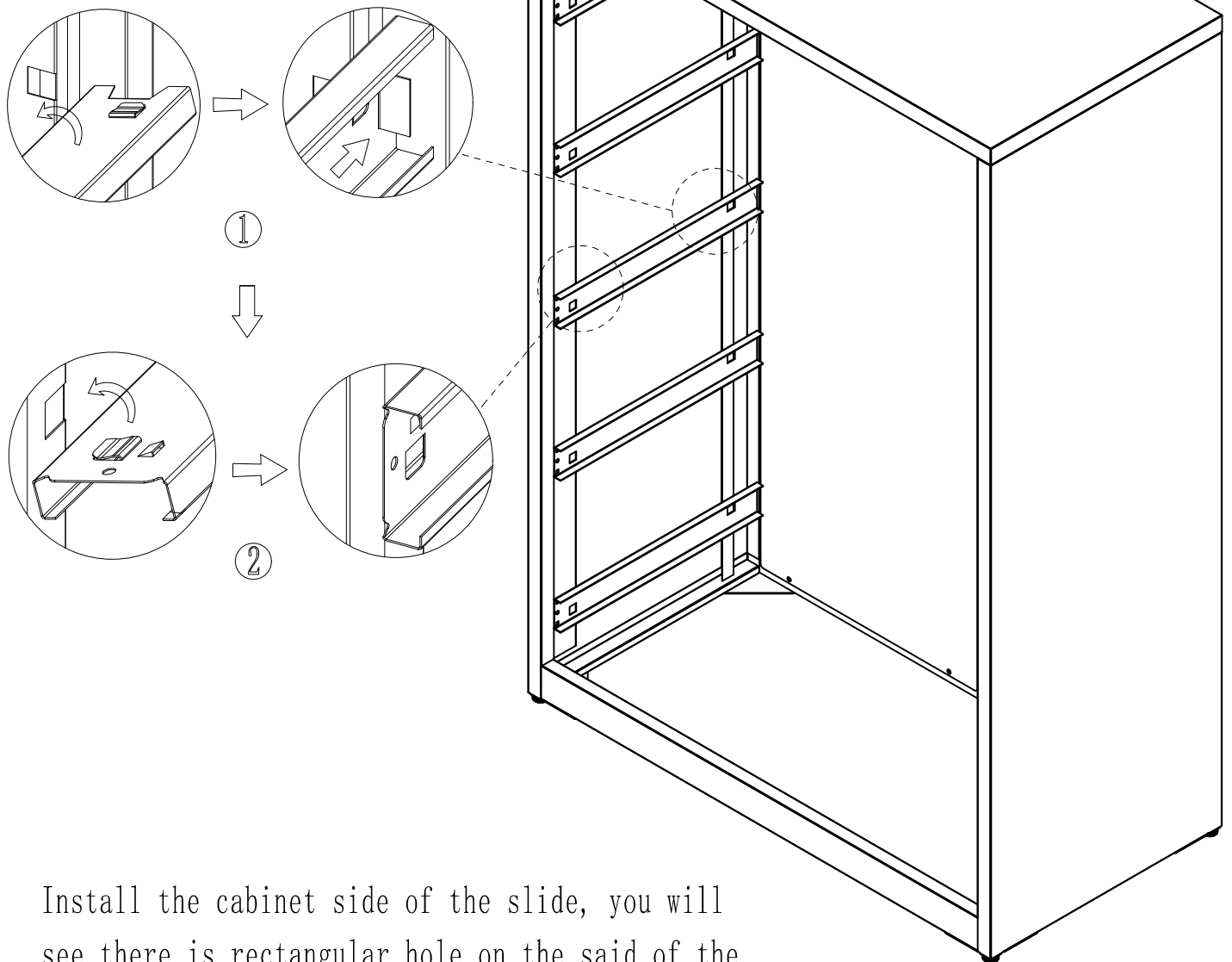

Install the cabinet side of the slide, you will see there is rectangular hole on the said of the drawer, then install metal side of slide onto both said of the cabinet.
Same process to finish the 5 life rail and 5 right rail.

15

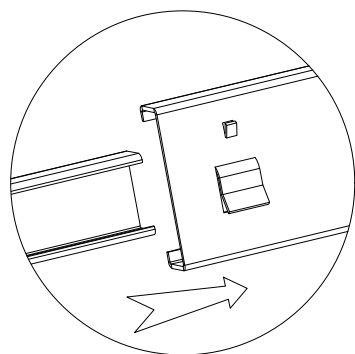
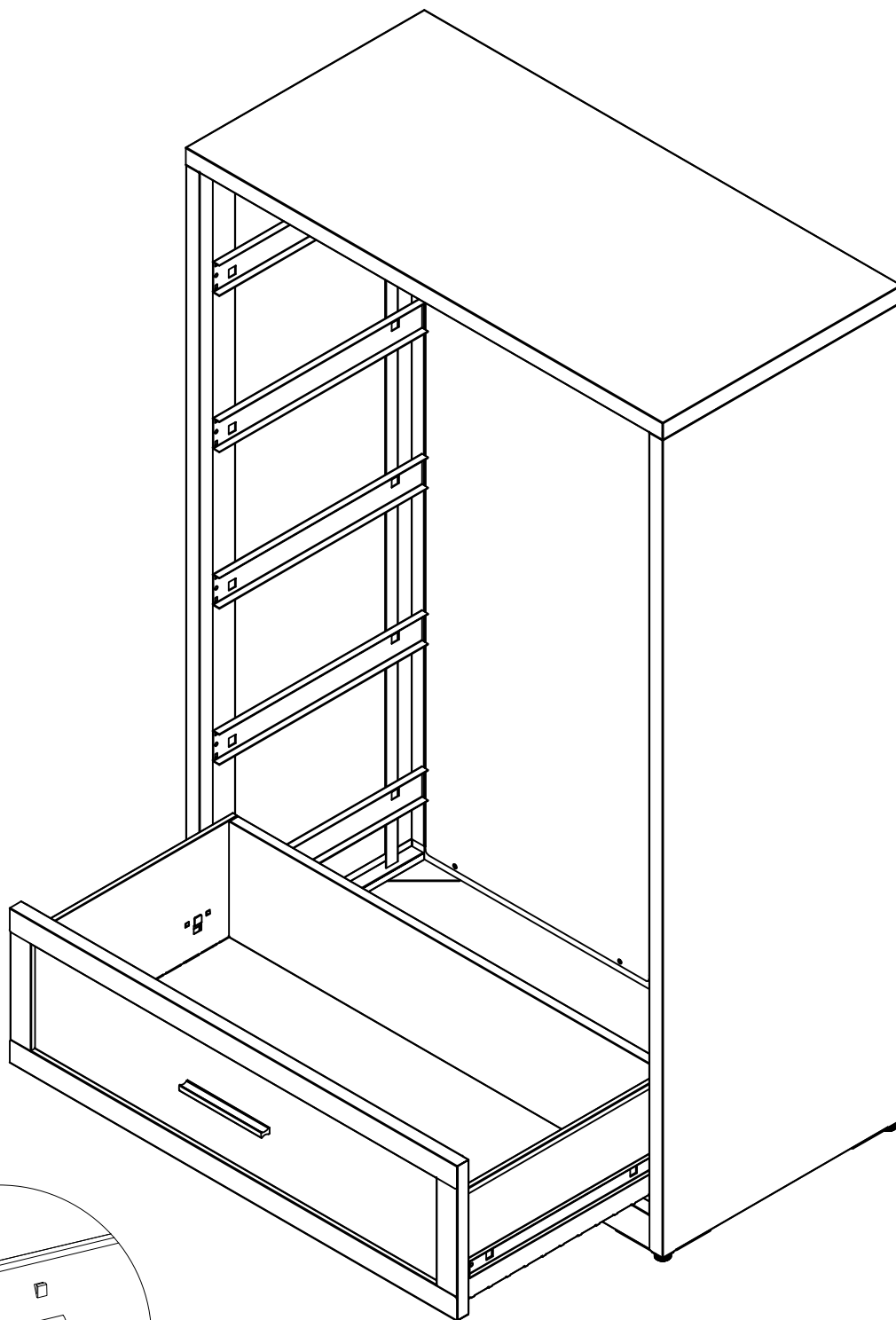

Pull the inner rails out, then insert the rail into glide, push down. (show in the picture).

16

L*2



S*2



W*2

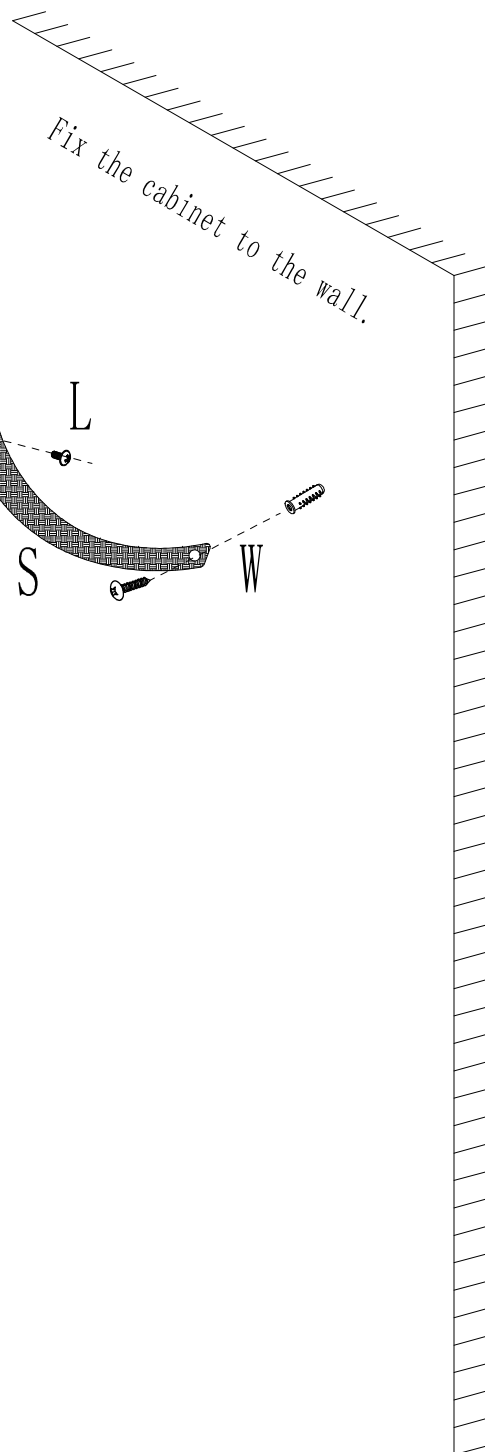
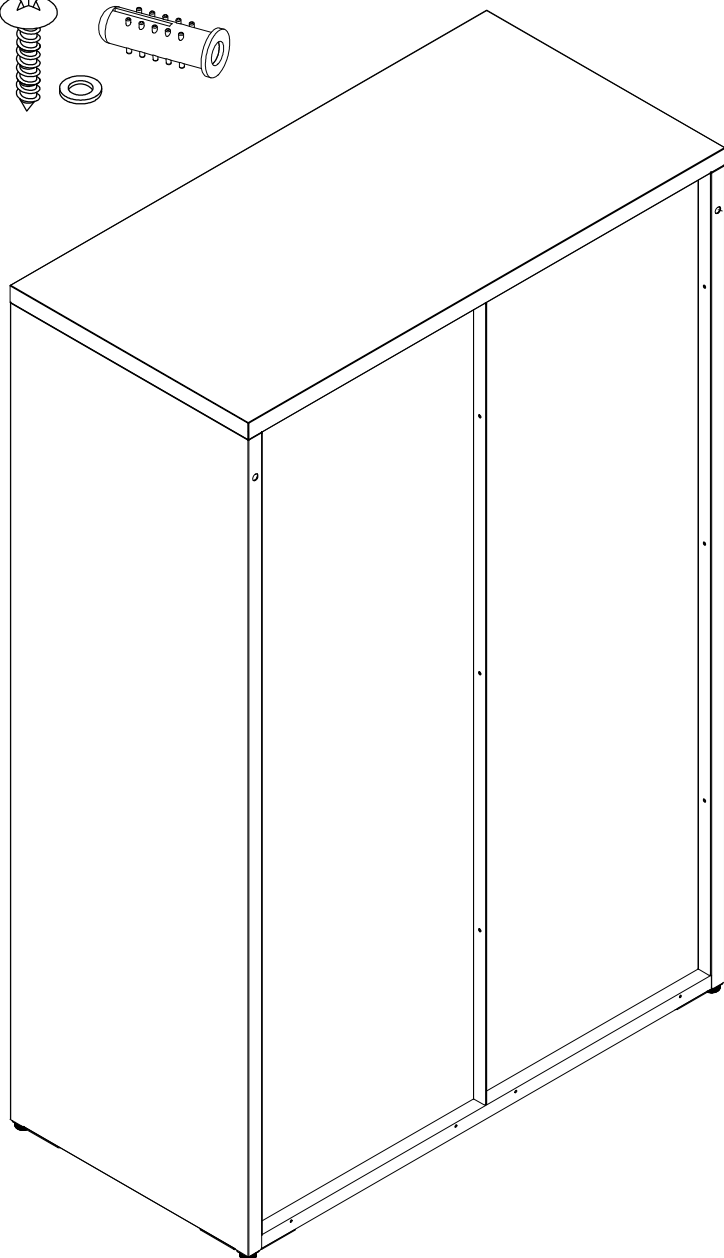
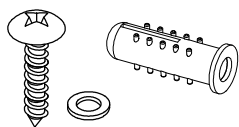

***WARNING**

(Serious or fatal crushing injuries can occur from furniture tip-over. To prevent this furniture from tipping over it must be permanently fixed to the wall.)

Align the holes of the wall anchors with the holes on the top cover of the cabinet.

Using the L screws fasten the 2 anchors to the top of the cabinet.

Push the metal cabinet against the wall. Mark the places on the wall there you are going to drill. Take the Percussion Drill. Drill holes in the marked places.

Take wall plugs W & insert in the drilled holes using a hammer.

Fix the wall anchors to the wall using 1 screw W .

Your metal cabinet is ready to use!

THANK YOU FOR BEING PART OF OUR STORY.

