

ASSEMBLY INSTRUCTIONS

ITEM NO: N719P236925 & N719P236898 & N719P236927

DESCRIPTION: SECTIONAL

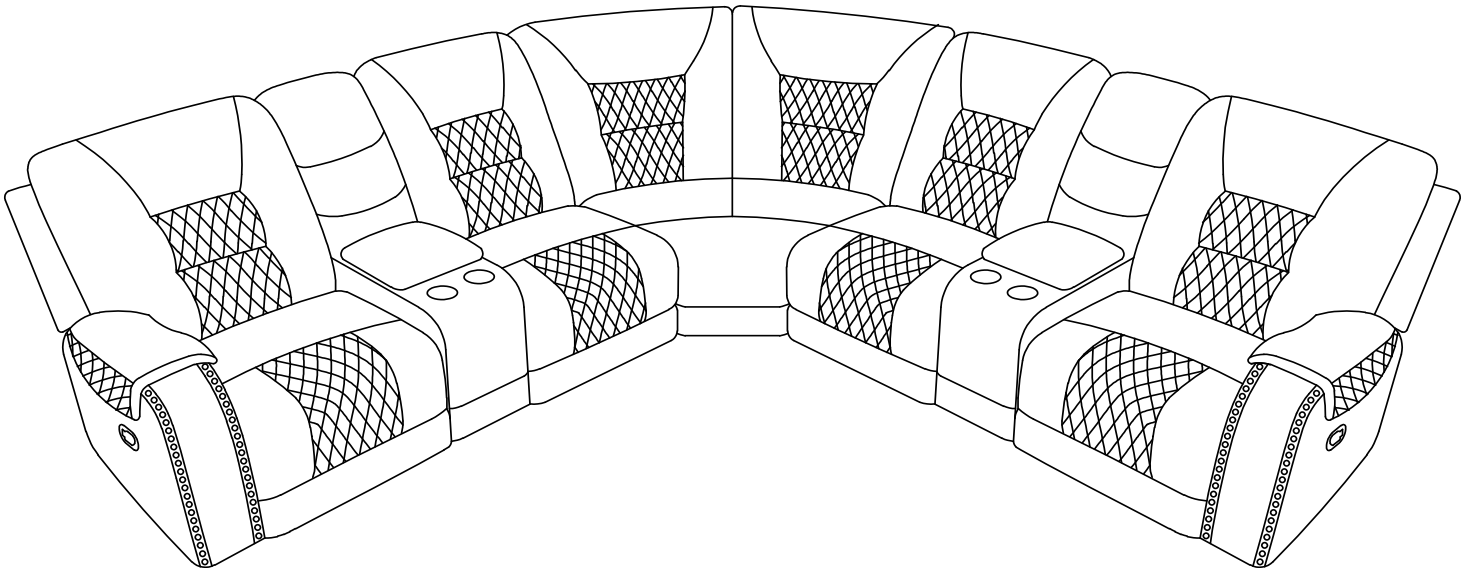

ASSEMBLY INSTRUCTIONS

ITEM NO: N719P236925 & N719P236898 & N719P236927

DESCRIPTION: SECTIONAL

PARTS AND HARDWARE

Avoid using sharp objects such as a knife to cut open packing as you may accidentally damage the upholstery.

N719P236898

A*1

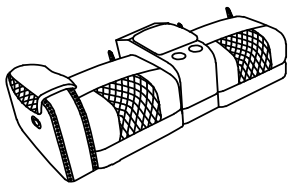

Left Seat Base

D*1

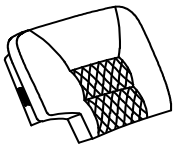

Left Back Rest

F*1

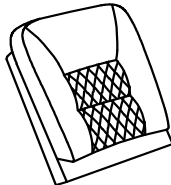

Armless Back Rest

H*1



Console Back Rest

I*1



Left Wing

K*1



Adaptor

N719P236925

B*1

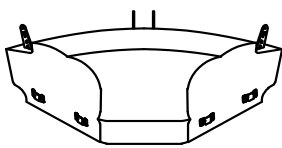

Corner Seat Base

G*2

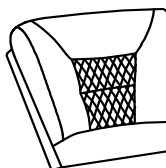

Corner Back Rest

N719P236927

C*1

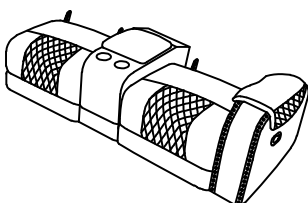

Right Seat Base

E*1

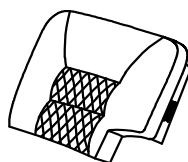

Right Back Rest

F*1

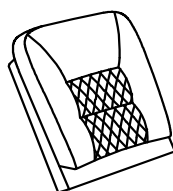

Armless Back Rest

H*1



Console Back Rest

J*1

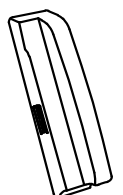

Right Wing

ASSEMBLY INSTRUCTIONS

ITEM NO: N719P236925 & N719P236898 & N719P236927

DESCRIPTION: SECTIONAL

CAUTION: At least two adults are required to safely complete performing this task. Other lifting attempts may risk back injury due to large and heavy part(s).

Step 1. Carefully unpack and place parts on a clean flat surface.

Remark: Take out the console back (H) from the bottom of part (A&B).

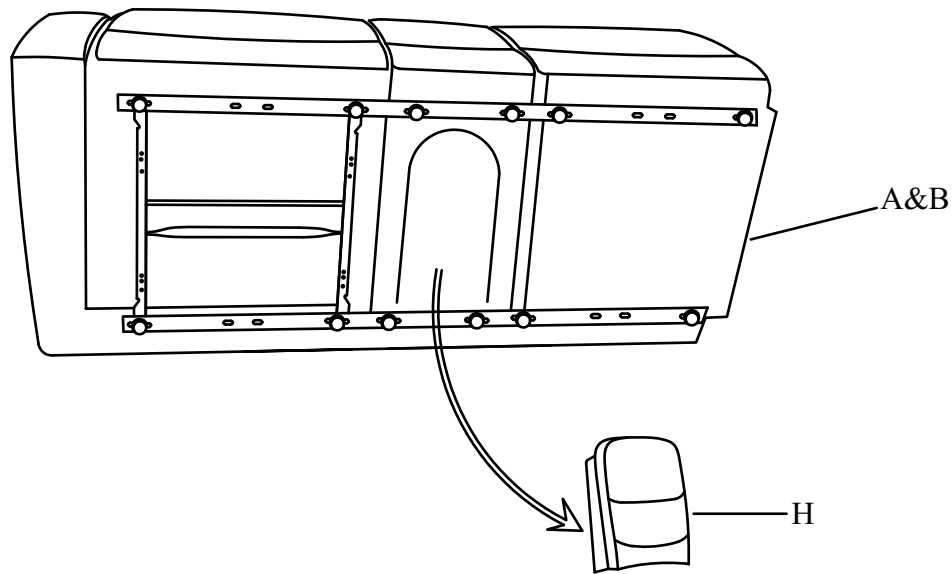

Step 2. Attach the Back Rest to Seat Body
Ensure it is correctly in place.

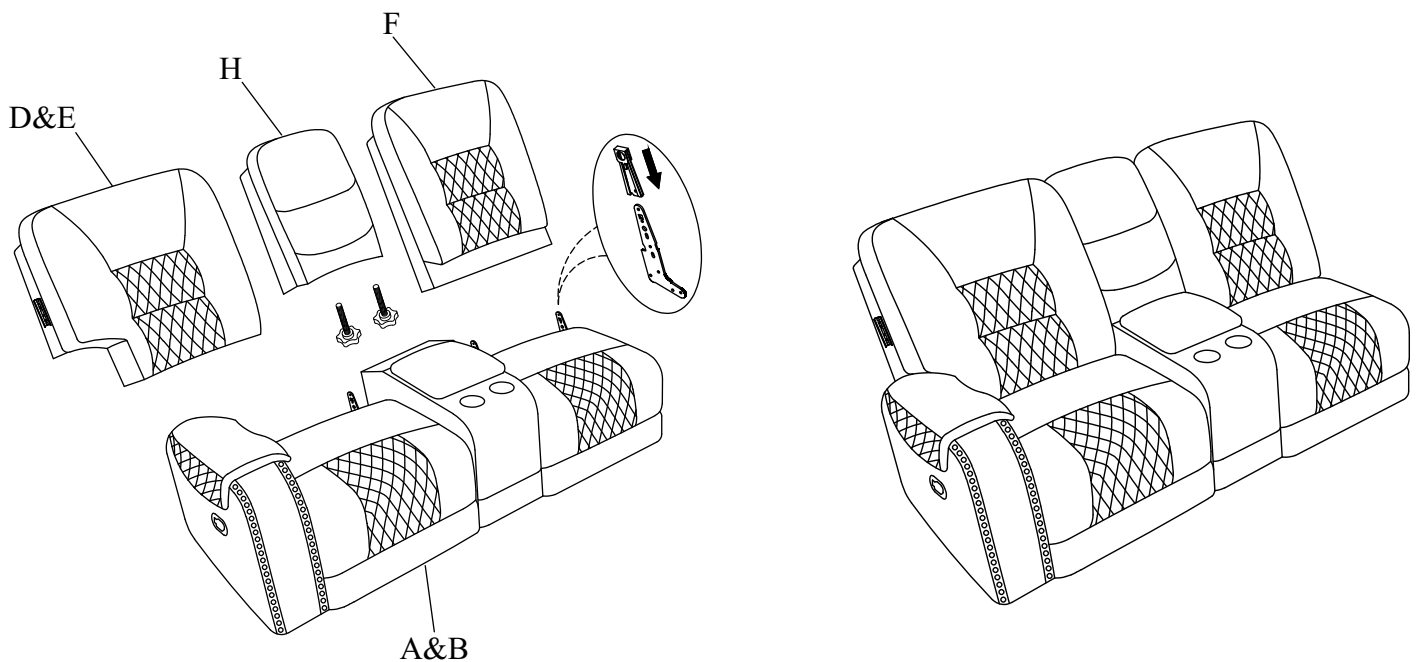

ASSEMBLY INSTRUCTIONS

ITEM NO: N719P236925 & N719P236898 & N719P236927

DESCRIPTION: SECTIONAL

CAUTION: At least two adults are required to safely complete performing this task. Other lifting attempts may risk back injury due to large and heavy part(s).

Step 3. Attach the Left Wing (I) & Right Wing (J) to Back Rest (D,E)
Ensure it is correctly in place.

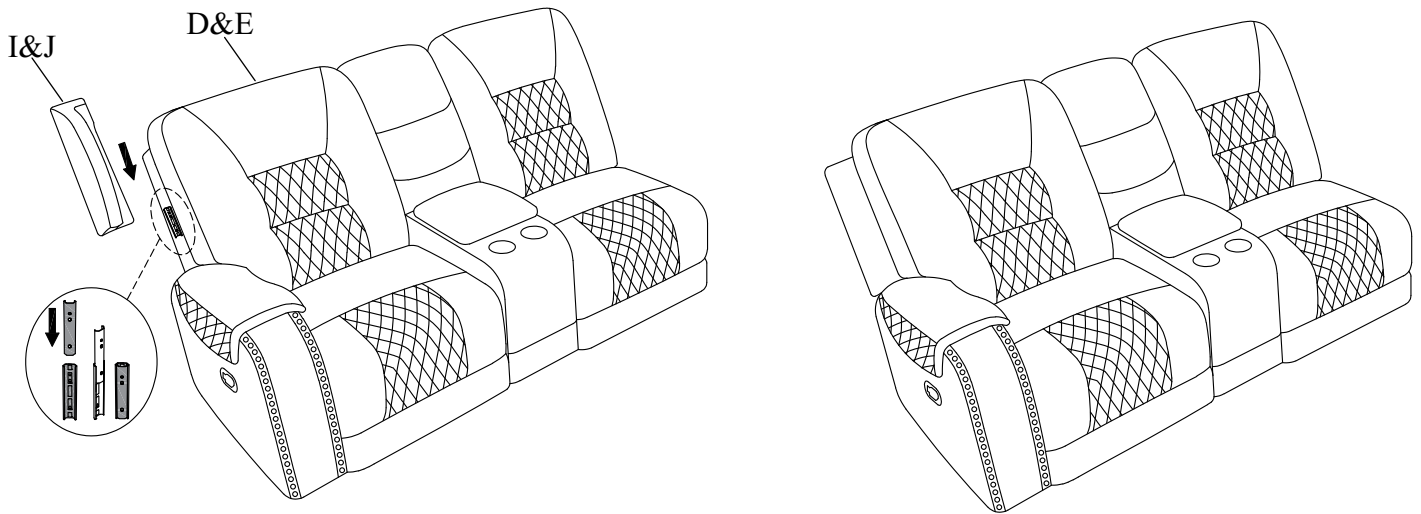

Step 4. Attach the Corner Back Rest (G) to Corner Seat Base (B)
Ensure it is correctly in place.

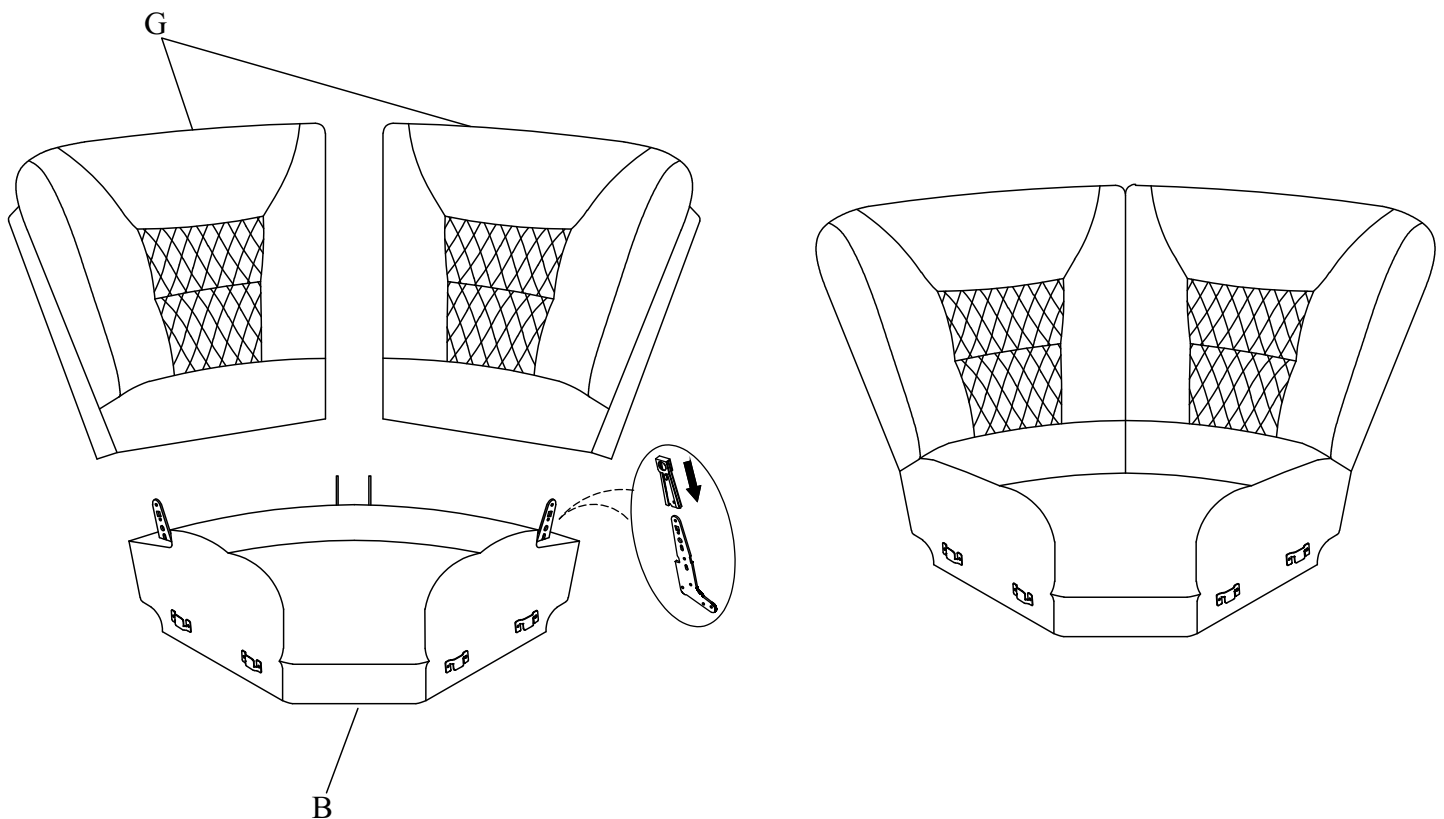

ASSEMBLY INSTRUCTIONS

ITEM NO: N719P236925 & N719P236898 & N719P236927

DESCRIPTION: SECTIONAL

CAUTION: At least two adults are required to safely complete performing this task. Other lifting attempts may risk back injury due to large and heavy part(s).

Step 5. Attach the Left Seat & Right Seat to angle Corner Seat
Ensure it is correctly in place.

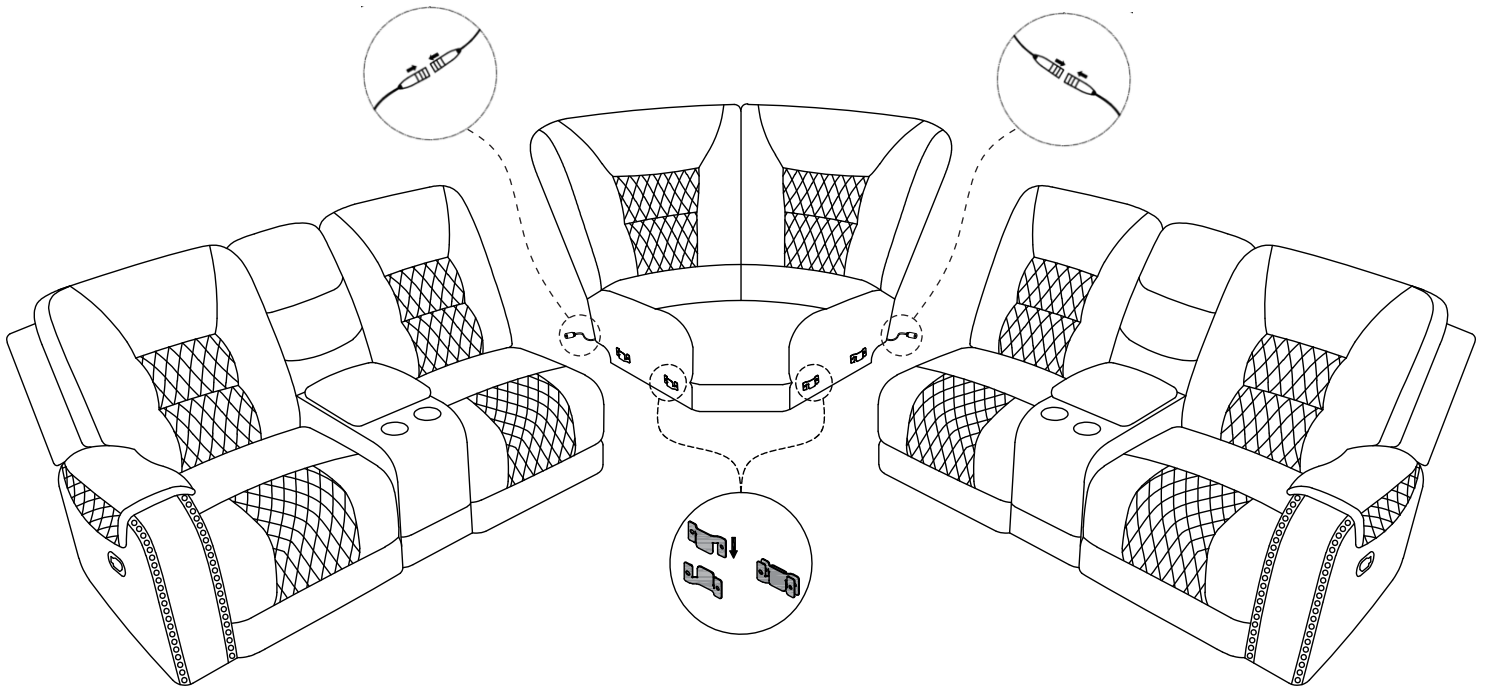

Step 6. Stretch and pull down rear cover evenly before securing velcro strip to seat base.
Repeat if necessary for better fit.

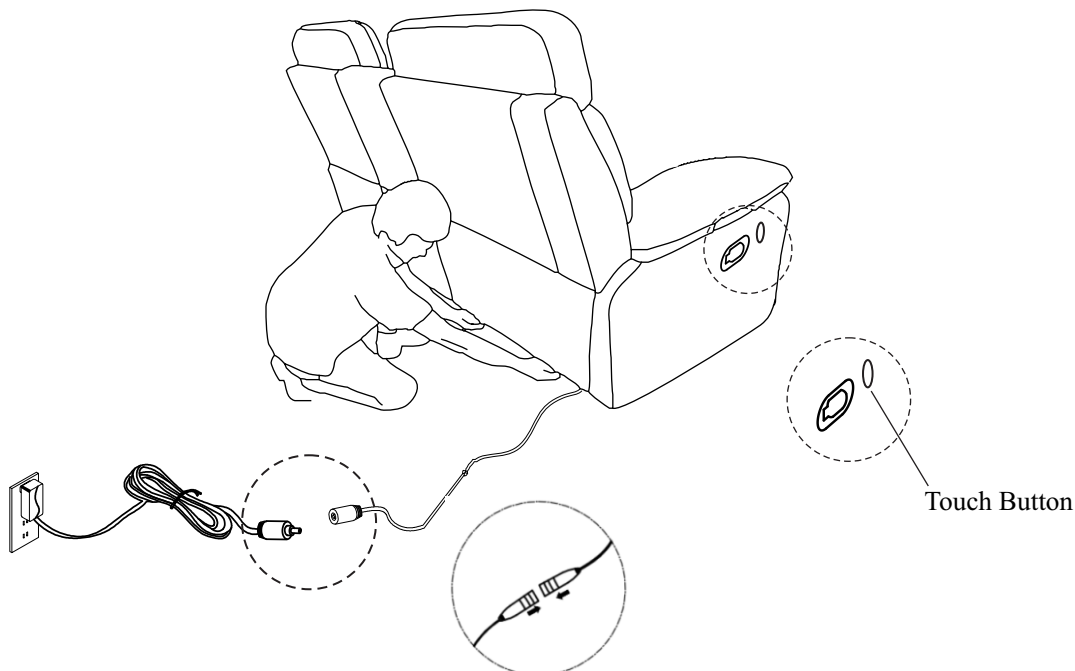

ASSEMBLY INSTRUCTIONS

ITEM NO: N719P236925 & N719P236898 & N719P236927

DESCRIPTION: SECTIONAL

CAUTION: At least two adults are required to safely complete performing this task. Other lifting attempts may risk back injury due to large and heavy part(s).

OPERATING YOUR UNIT

Converting to Footrest Position

-To raise or lower the legrest, push the power switch & hold. Release the switch when the legrest reaches the desired high

