

USER MANUAL

CABINET

TOOLS REQUIRED

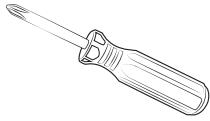

Phillips screwdriver
(Not included)

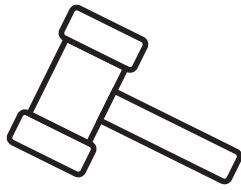

Hammer
(Not included)

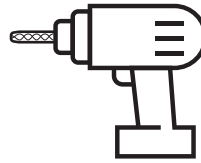

Drill
(Not included)



Protective blanket
(Not included)



ATTENTION

Keep children and pets away while assembling.



How to use cam locks

CAM LOCK FASTENING SYSTEM

This Cam Lock Fastening System will be used throughout the assembly process.

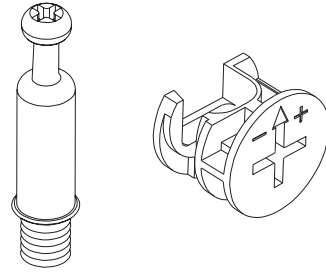

1

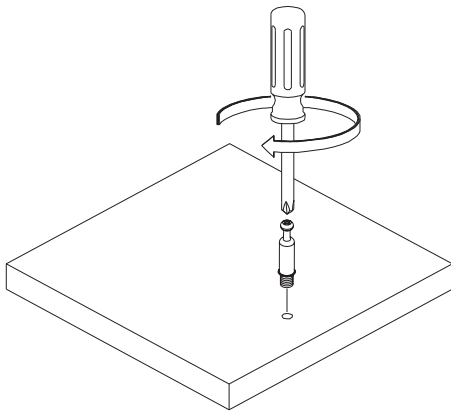

2

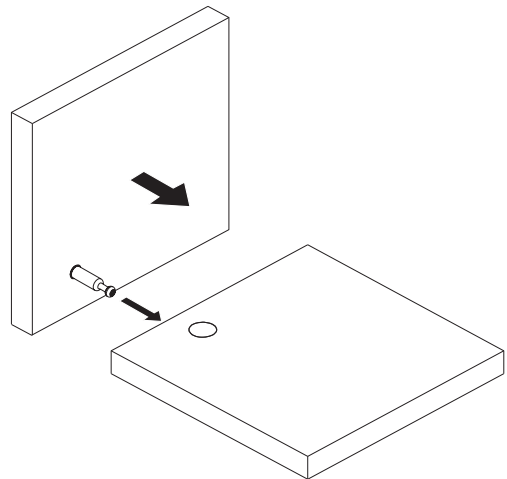

3

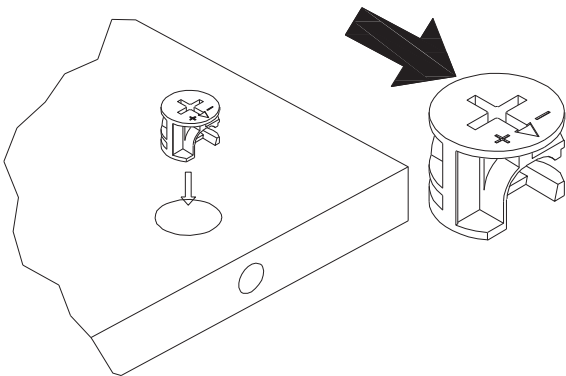

4

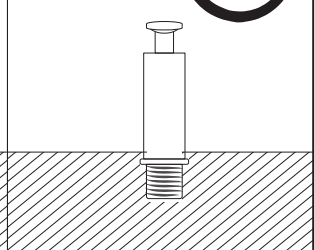
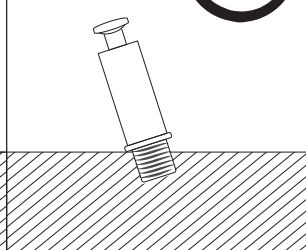
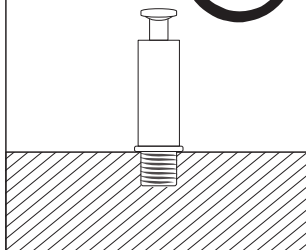
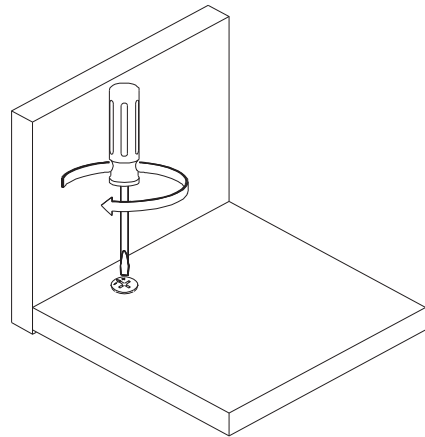





INTRODUCTION

Thank you very much for choosing our product. Please read the instruction carefully before assembly and keep it for future reference. If you need further assistance on assembly, please contact our customer service through email.

Tips:

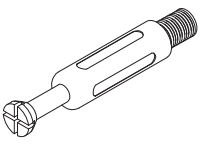
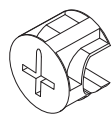
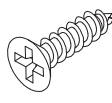
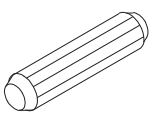
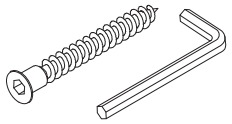
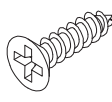
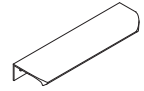
1. When installing the product, use a soft underlay (such as carpet or cardboard) to avoid scratching or damaging the surface of the product.
2. Don't tighten screws completely at first, just in case parts were assembled wrong and need disassemble. Tighten screws at last when all parts are put together.
3. The structure of this product can not meet the requirements of the placement of heavy items and children climbing.

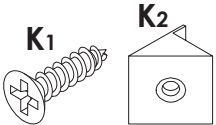
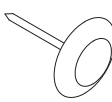
HARDWARES LIST

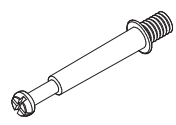
<p>A x30</p>  <p>M6*40mm</p>	<p>B x66</p>  <p>M15*11mm</p>	<p>C x36</p>  <p>M3.5*14mm</p>	<p>D x16</p>  <p>M8*40mm</p>
<p>E x54</p>  <p>M5*40mm</p>	<p>F x36</p>  <p>M3*12mm</p>	<p>H x6</p> 	<p>J x24</p> 
<p>K x24</p>  <p>M3*16mm</p>	<p>L x6</p> 	<p>M = CR + DR + CL + DL x6</p>  <p>12 INCHES</p>	
<p>N x2</p>  <p>N1 N2 N3 N4</p>		<p>P x36</p>  <p>M6*40mm</p>	

PRODUCT ASSEMBLY

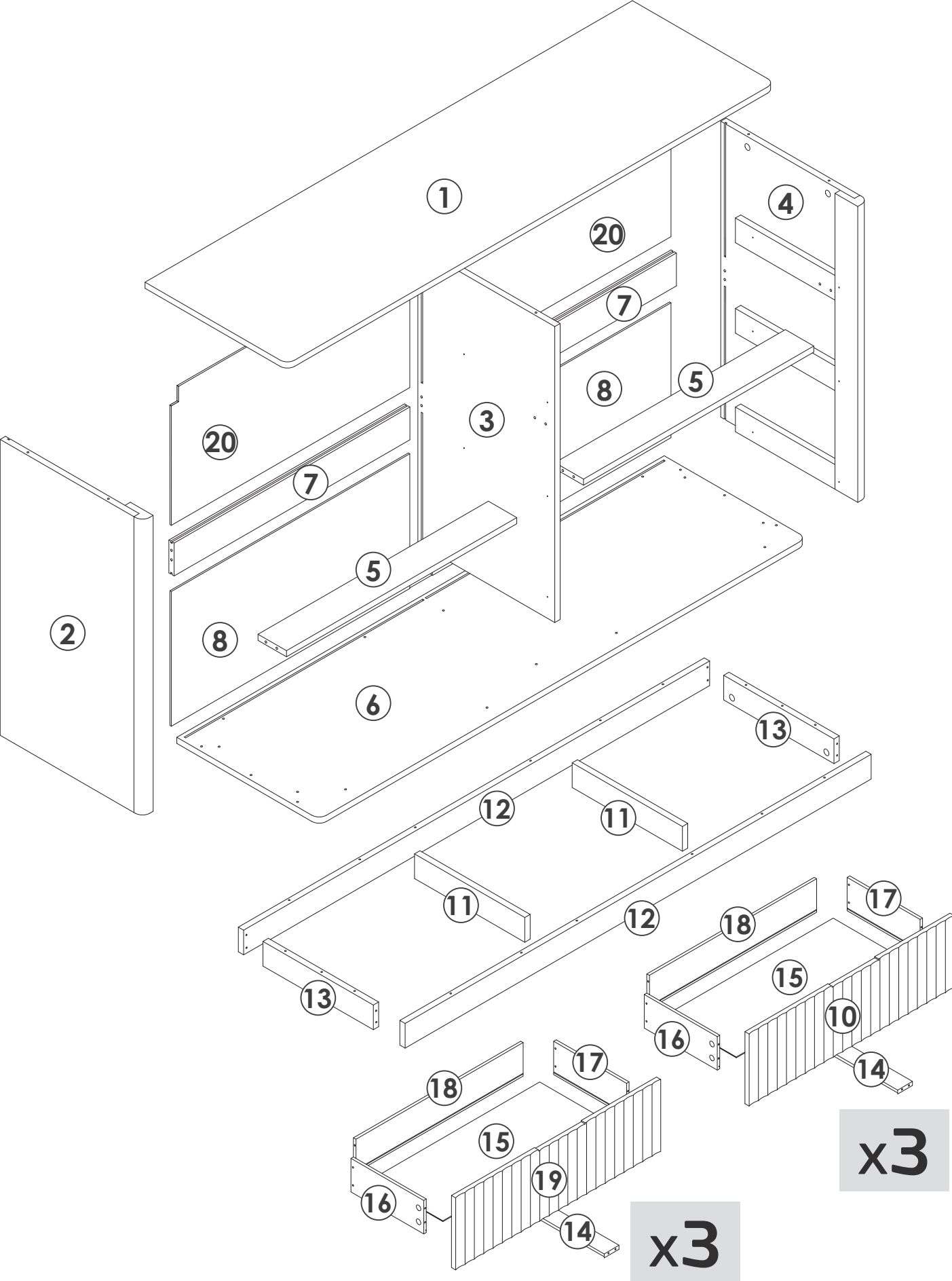

INSTALLATION INSTRUCTION

$$M = CR + DR + CL + DL$$

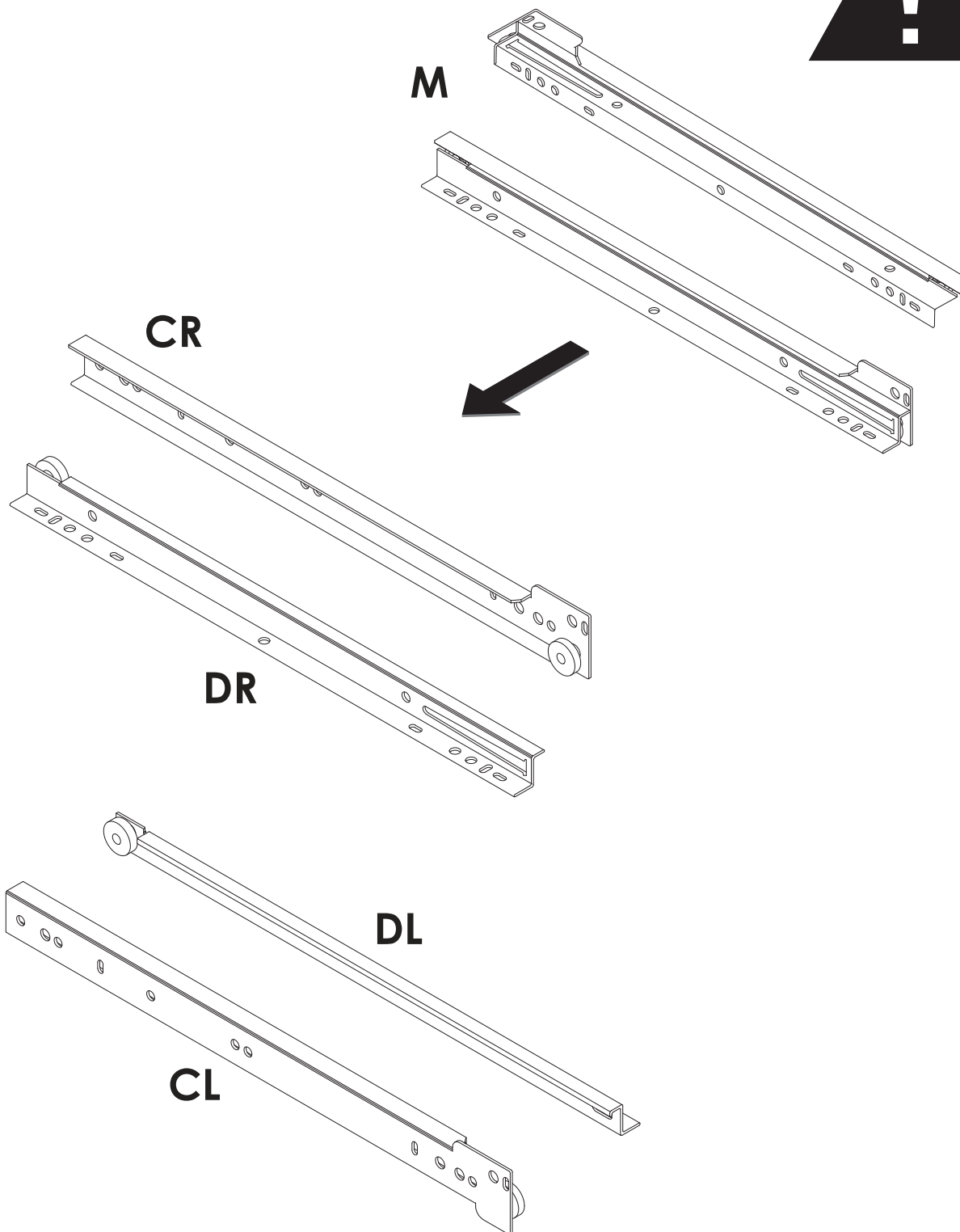

01

C x9pcs



M3.5*14mm

M x3pcs



12 inches

A x4pcs



M6*40mm

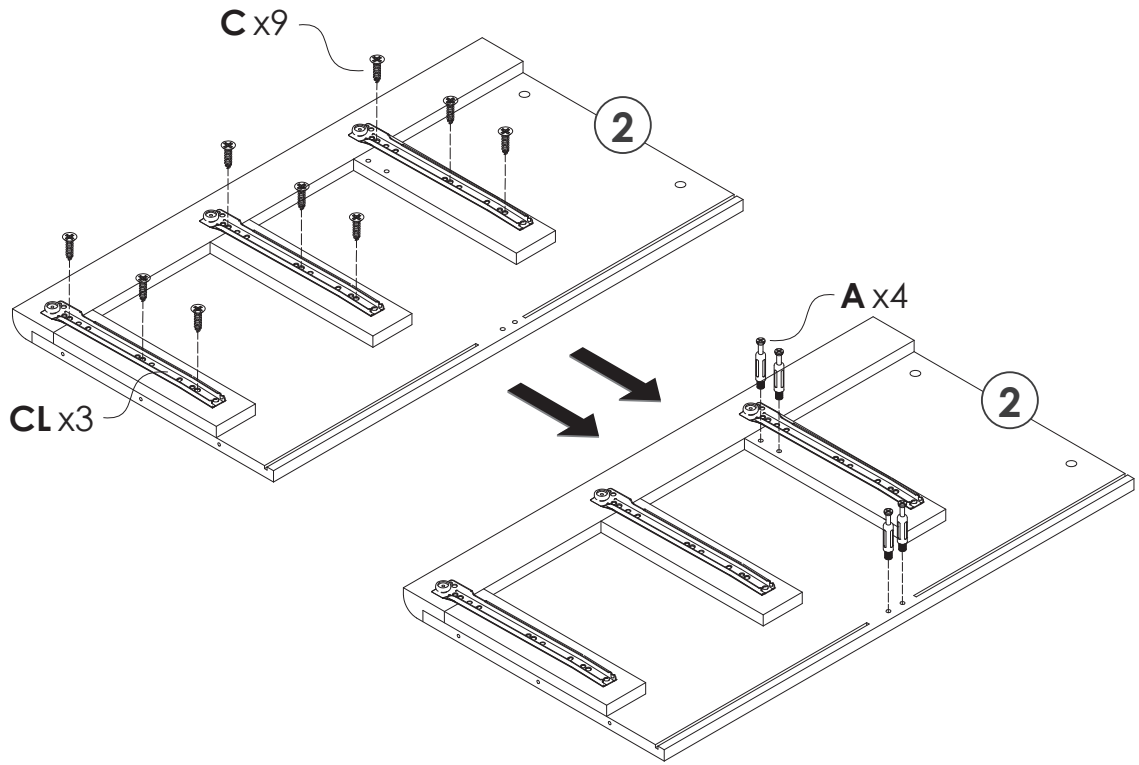
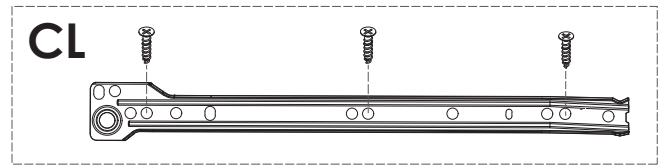

02

C x9pcs



M3.5*14mm

M x3pcs



12 inches

A x4pcs



M6*40mm

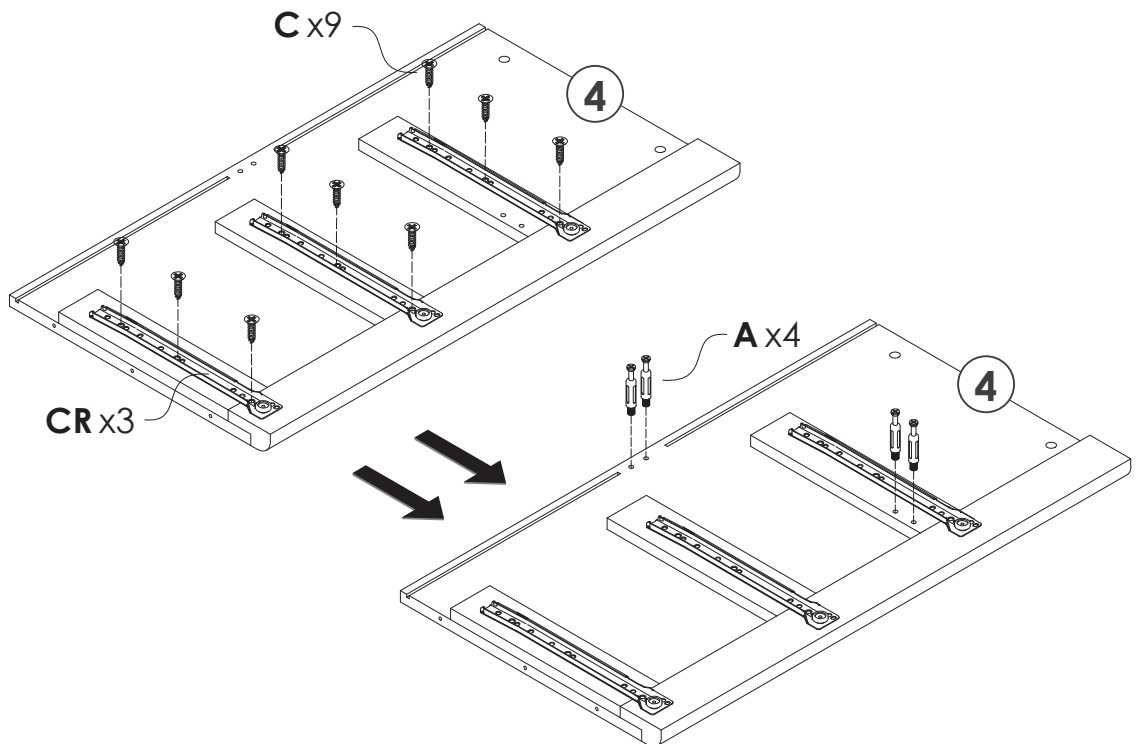
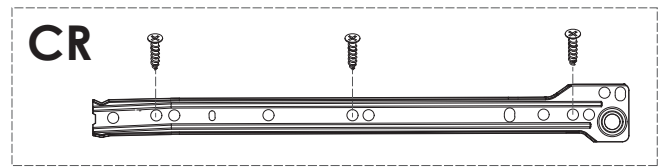

03

C x18pcs



M3.5*14mm

M x3pcs

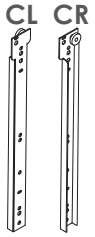

12 inches

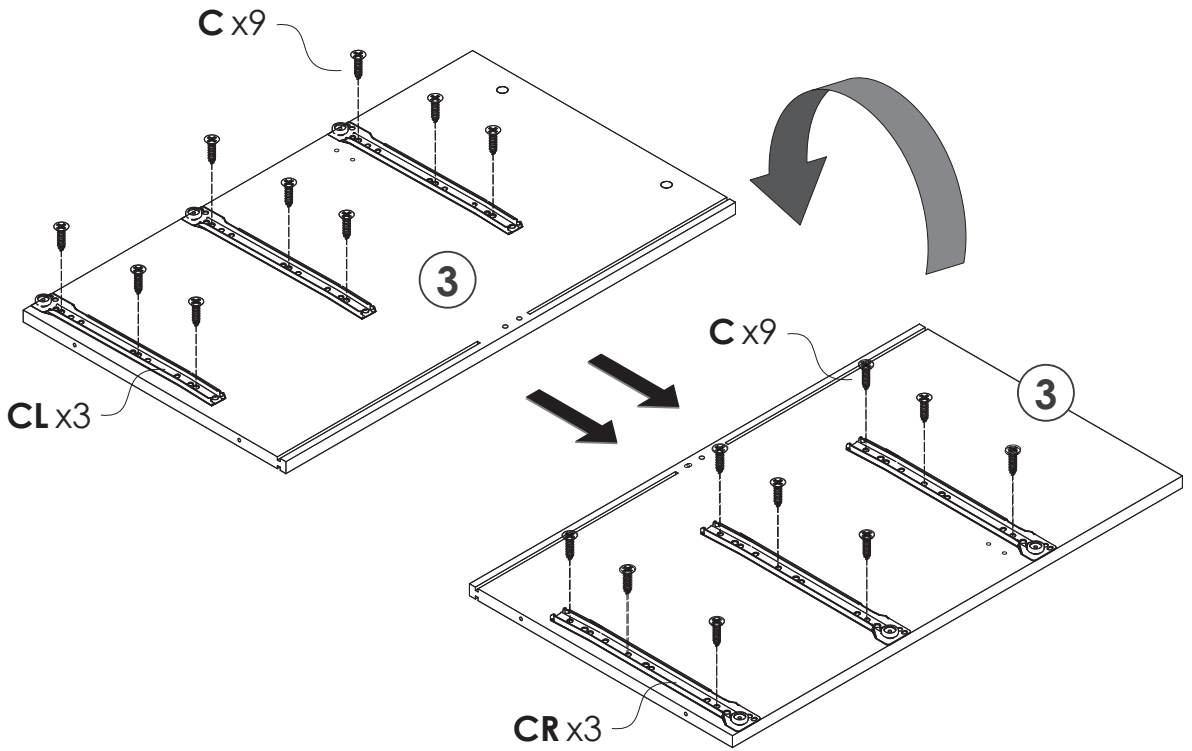

04

A x4pcs



M6*40mm

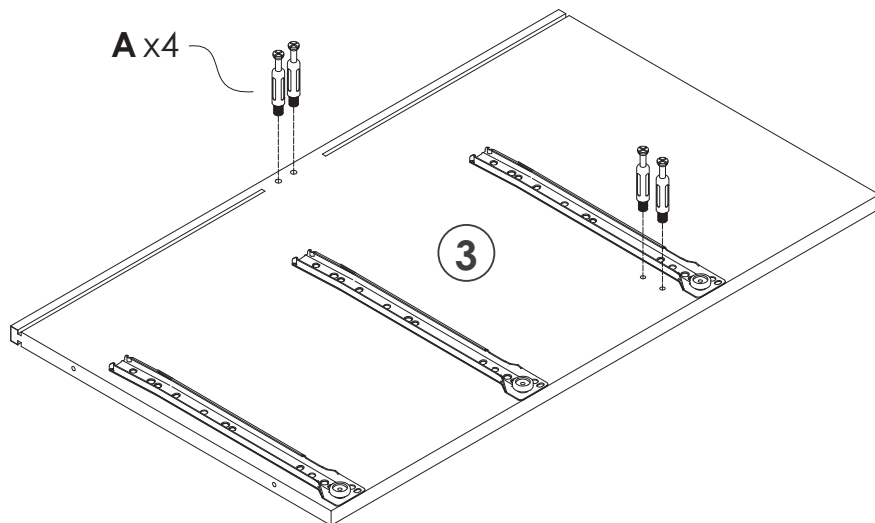

05

B x4pcs
M15*11mm

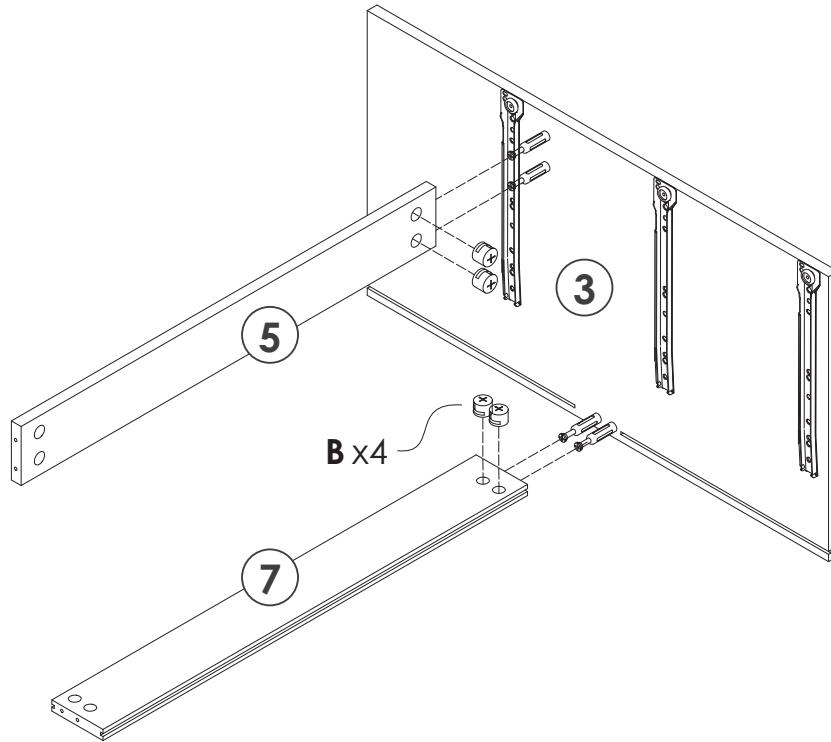

06

B x4pcs
M15*11mm

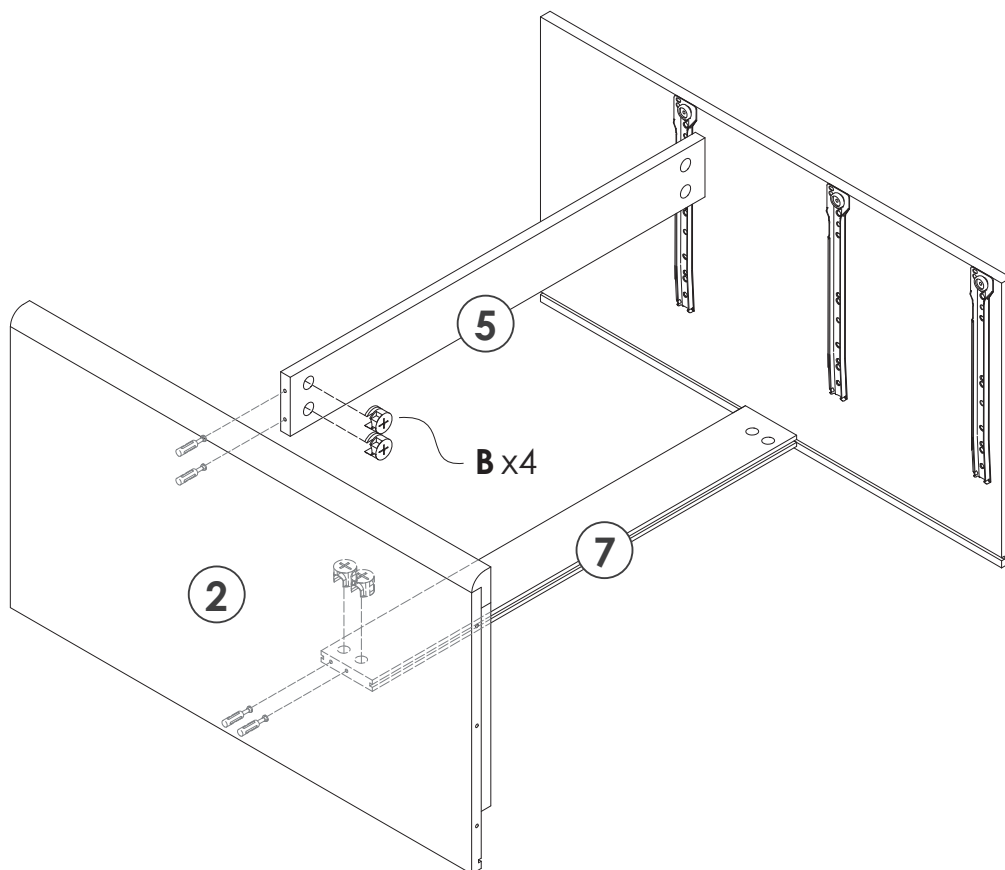

07

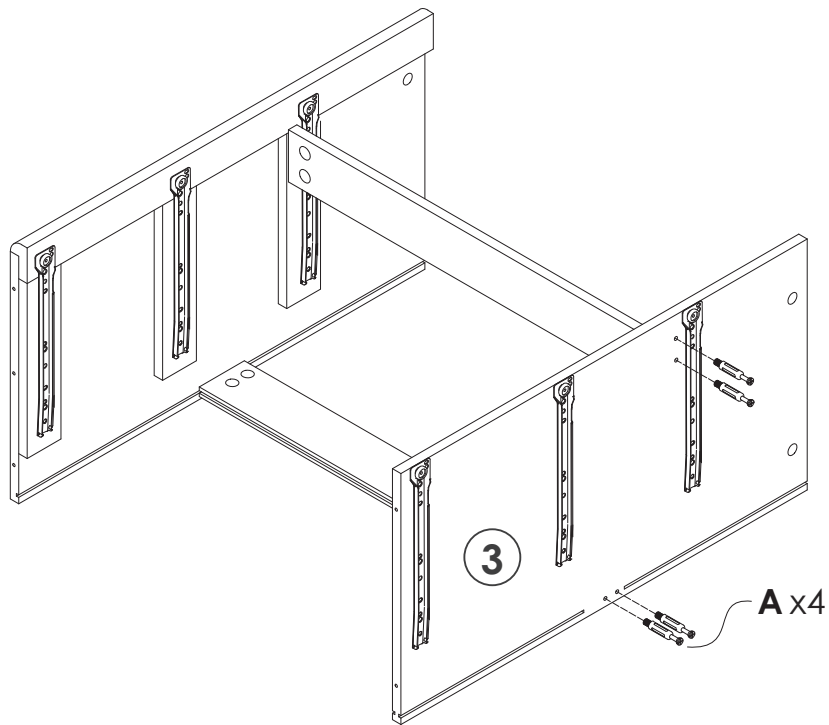
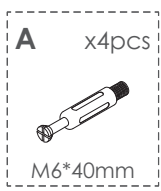

08

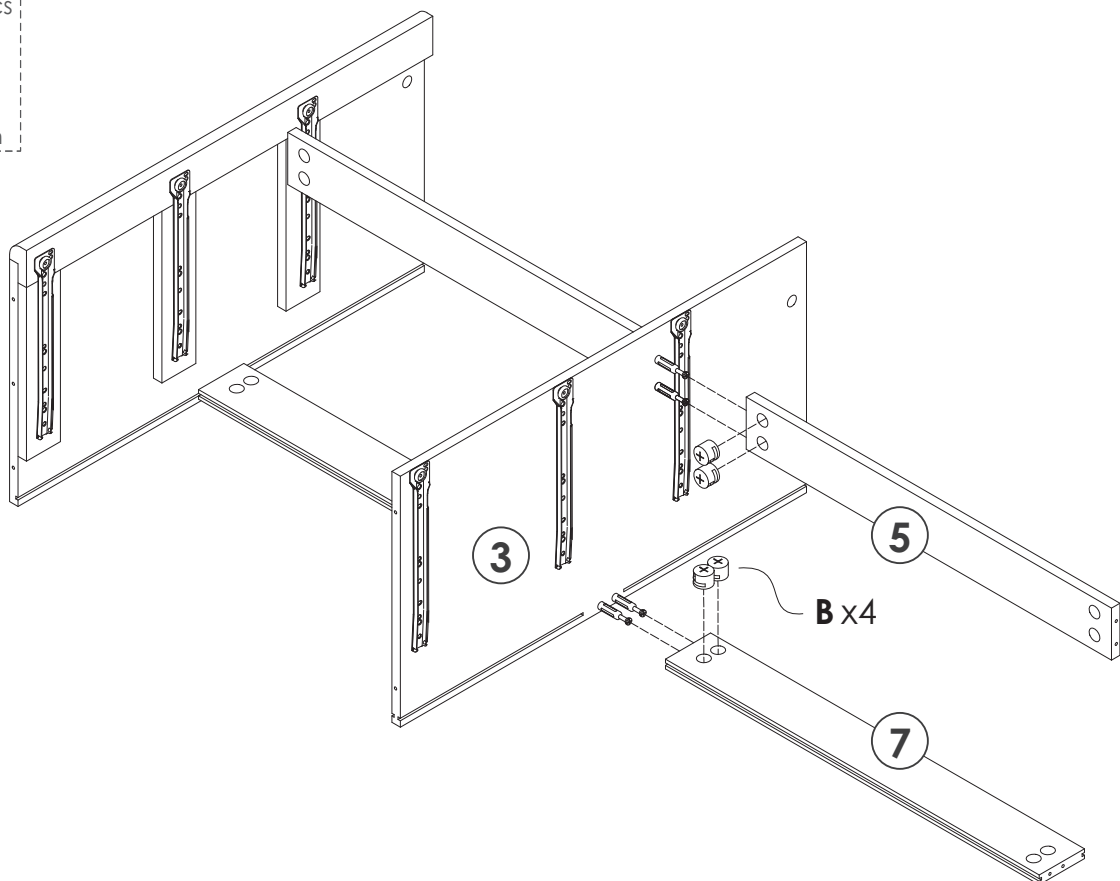
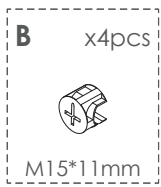

09

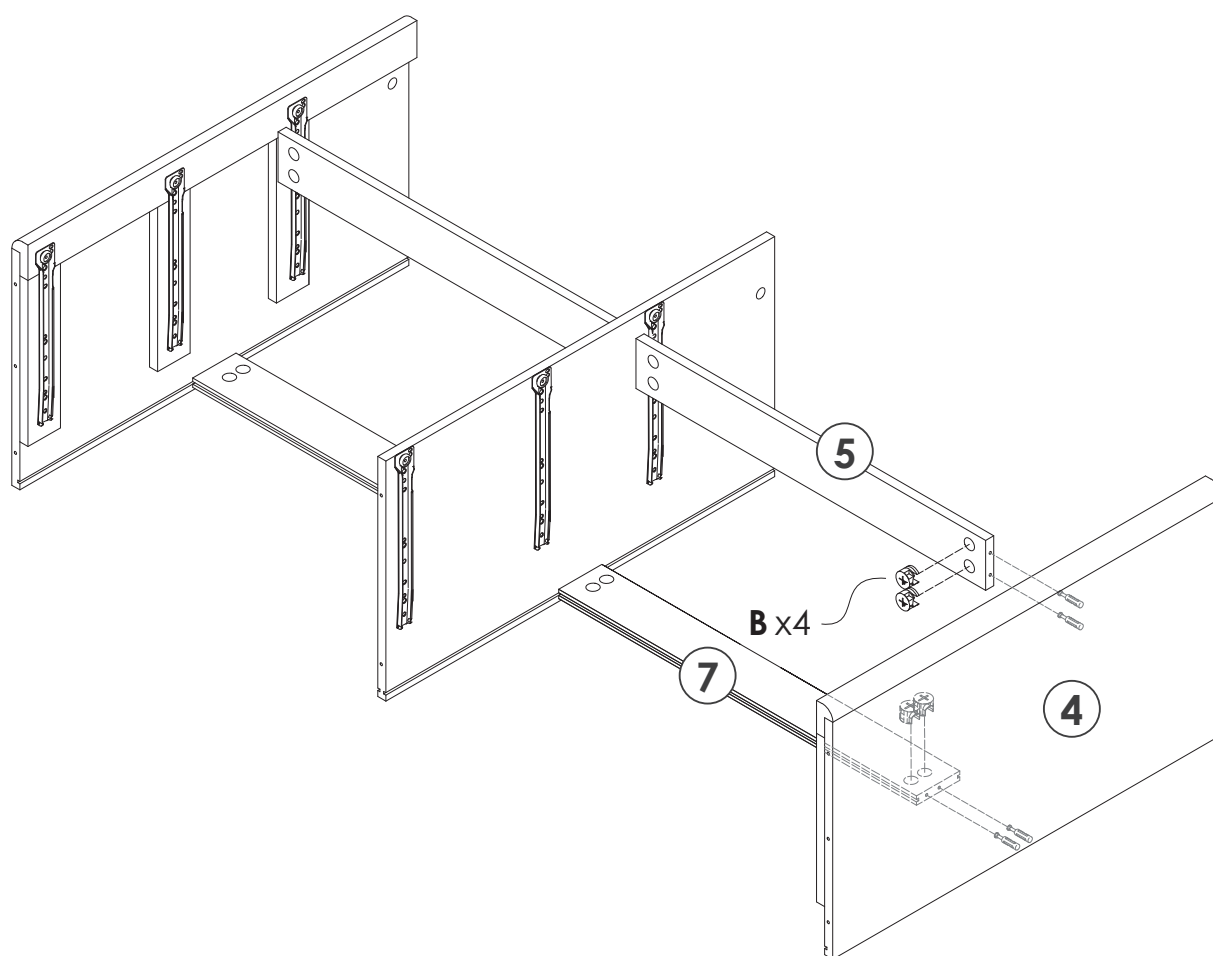
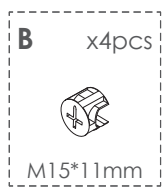

10

D x2pcs



M8*40mm

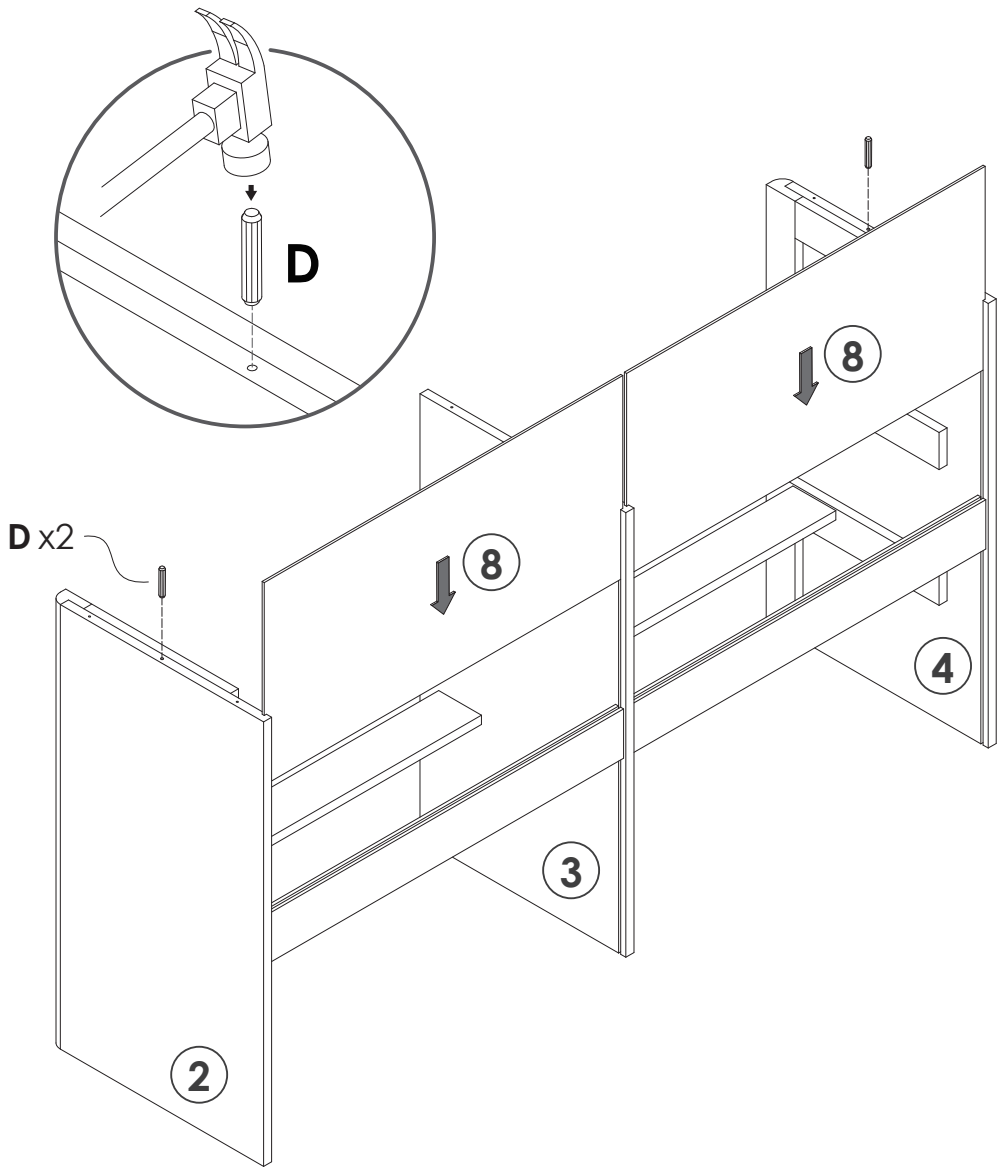

11

A x8pcs



M6*40mm

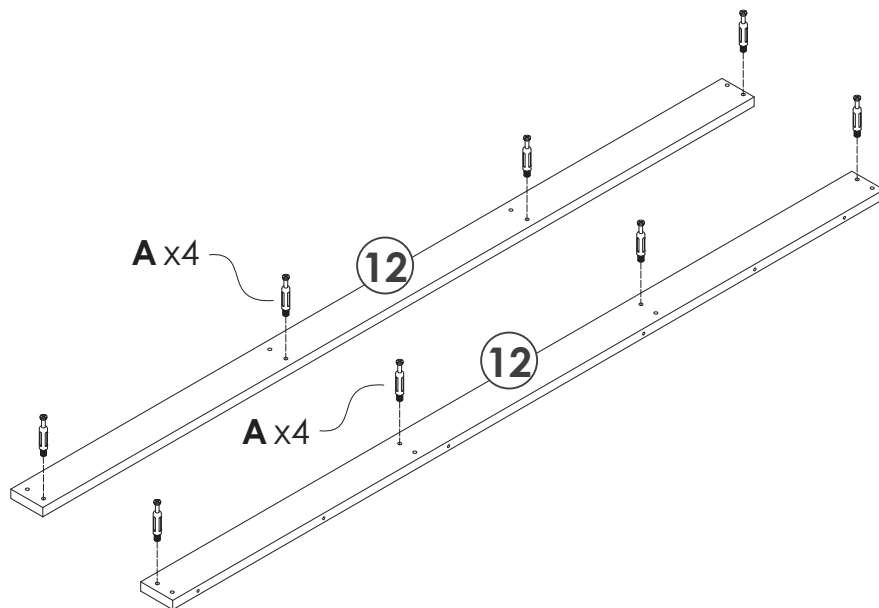

12

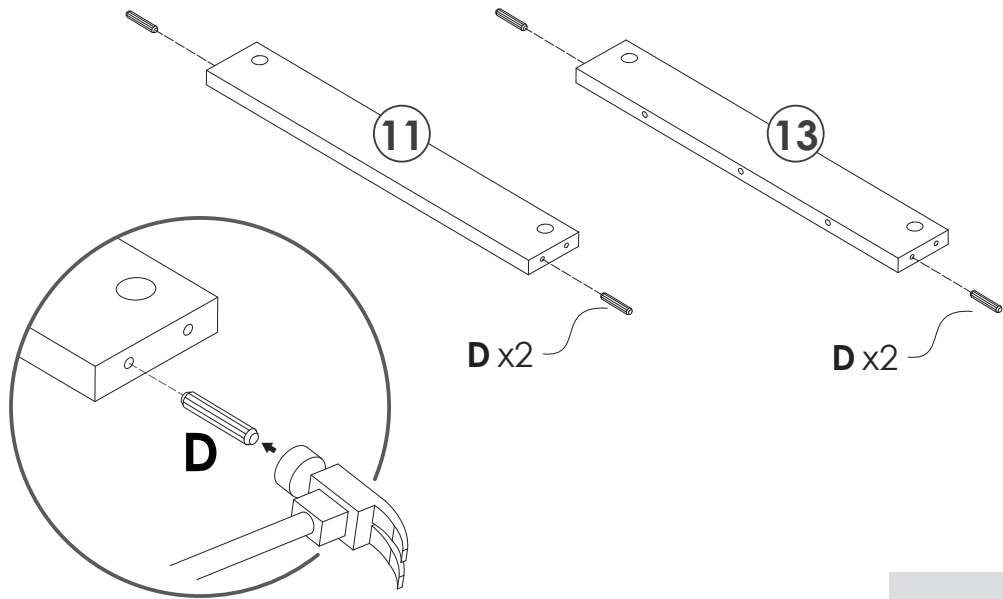
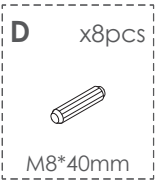

x2

13

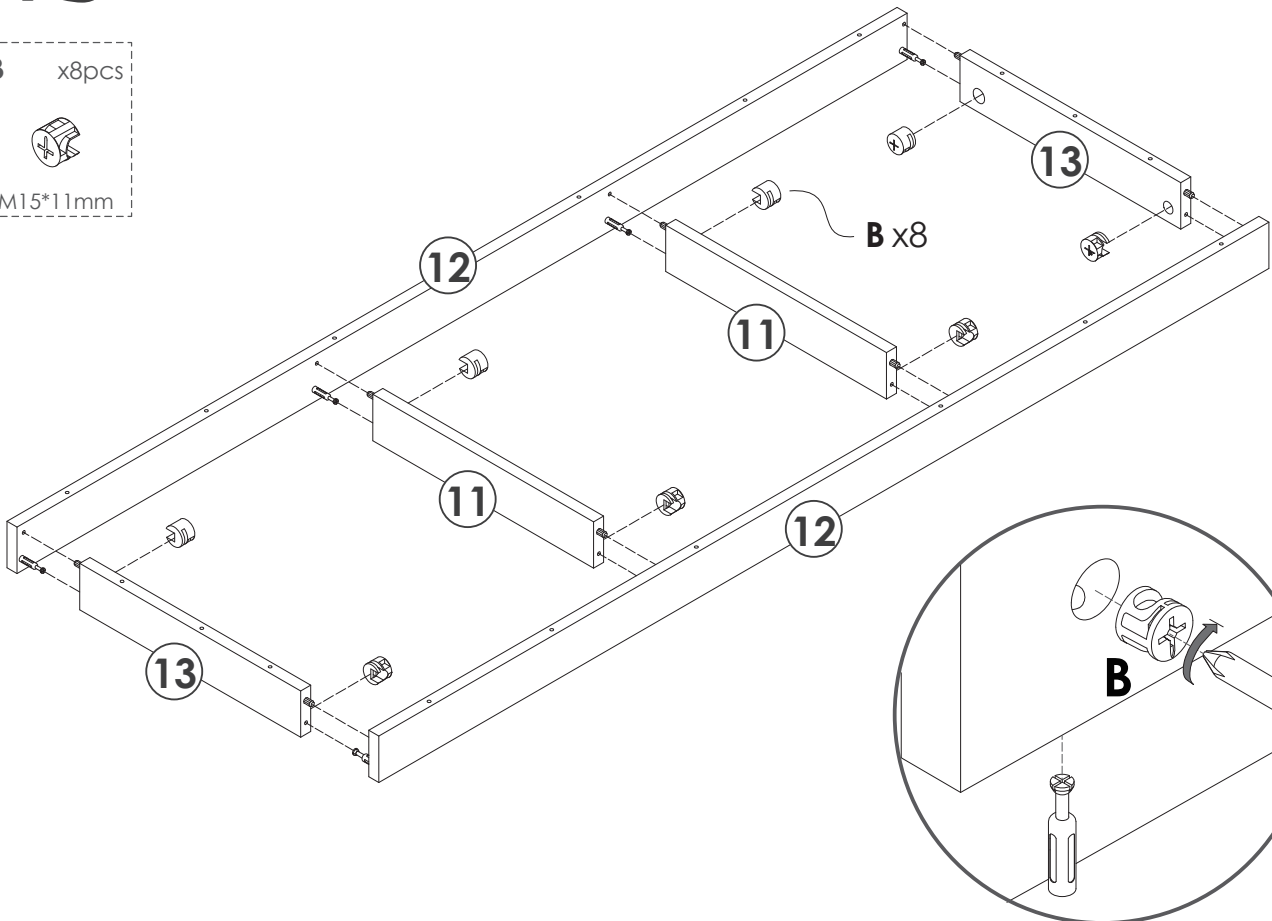
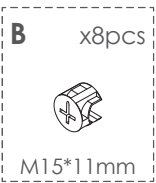

14

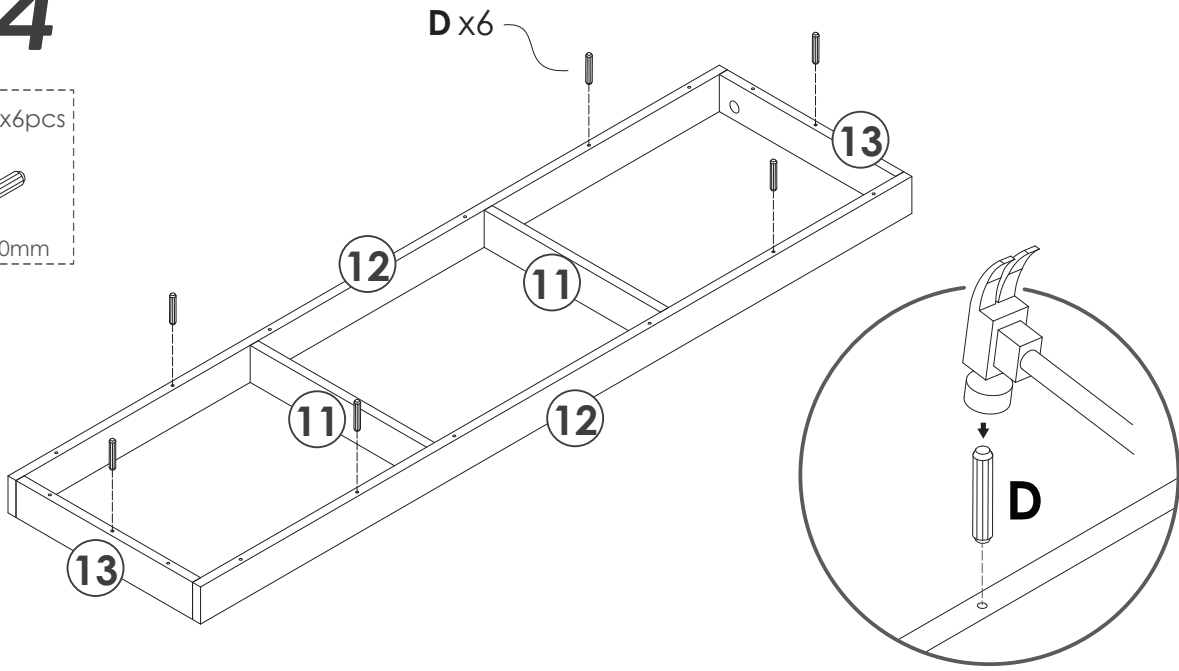
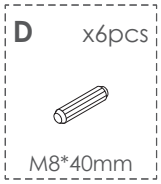

15

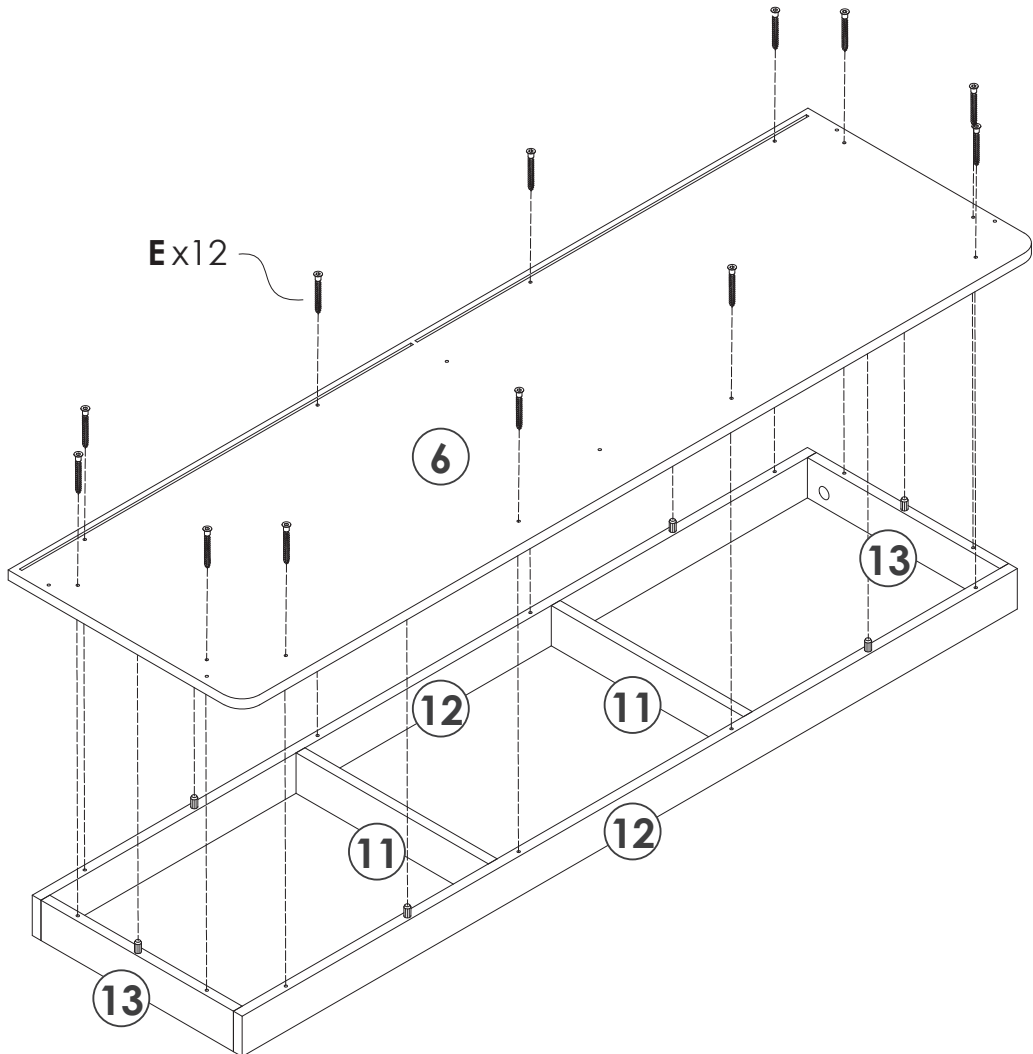

16

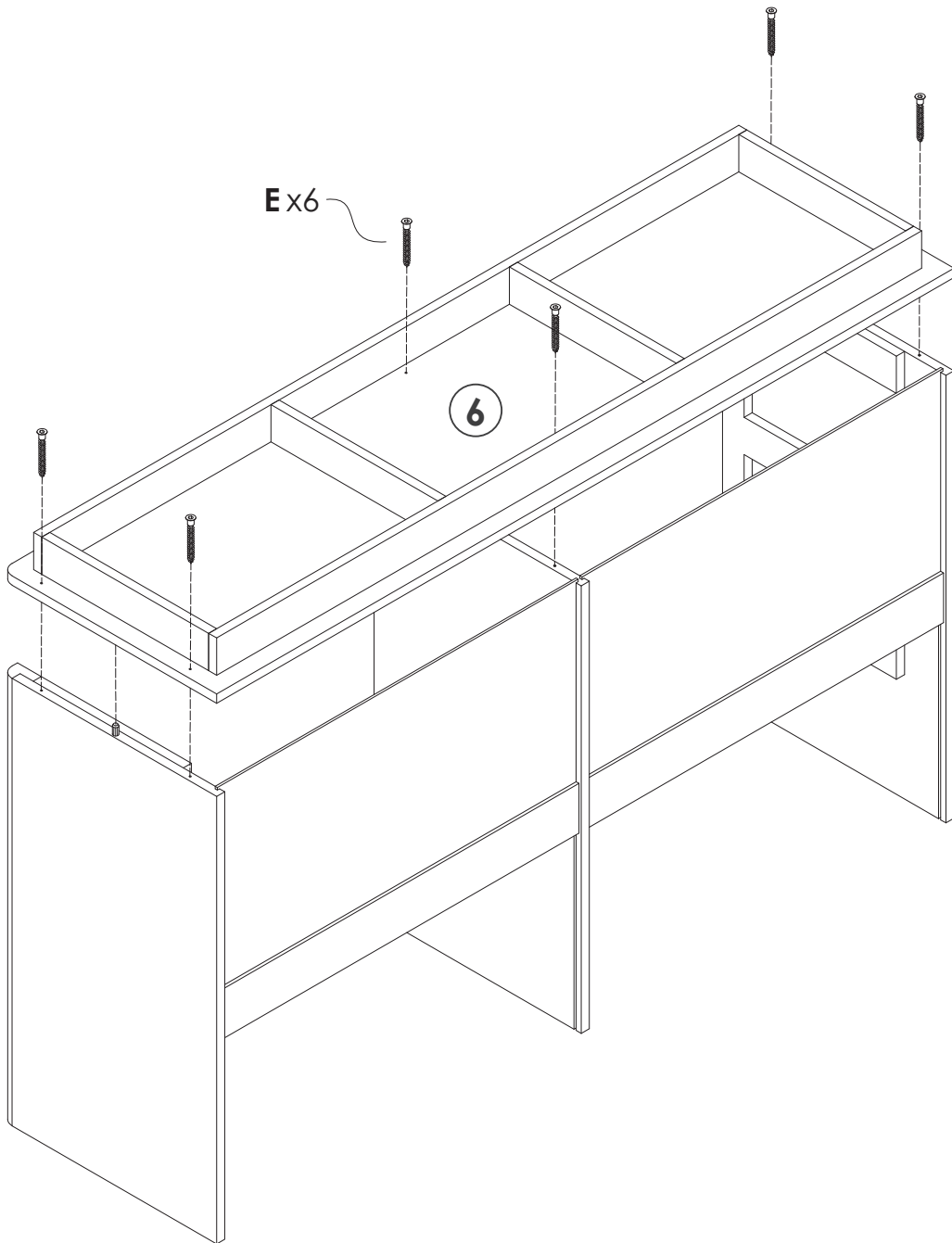
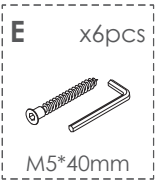

17

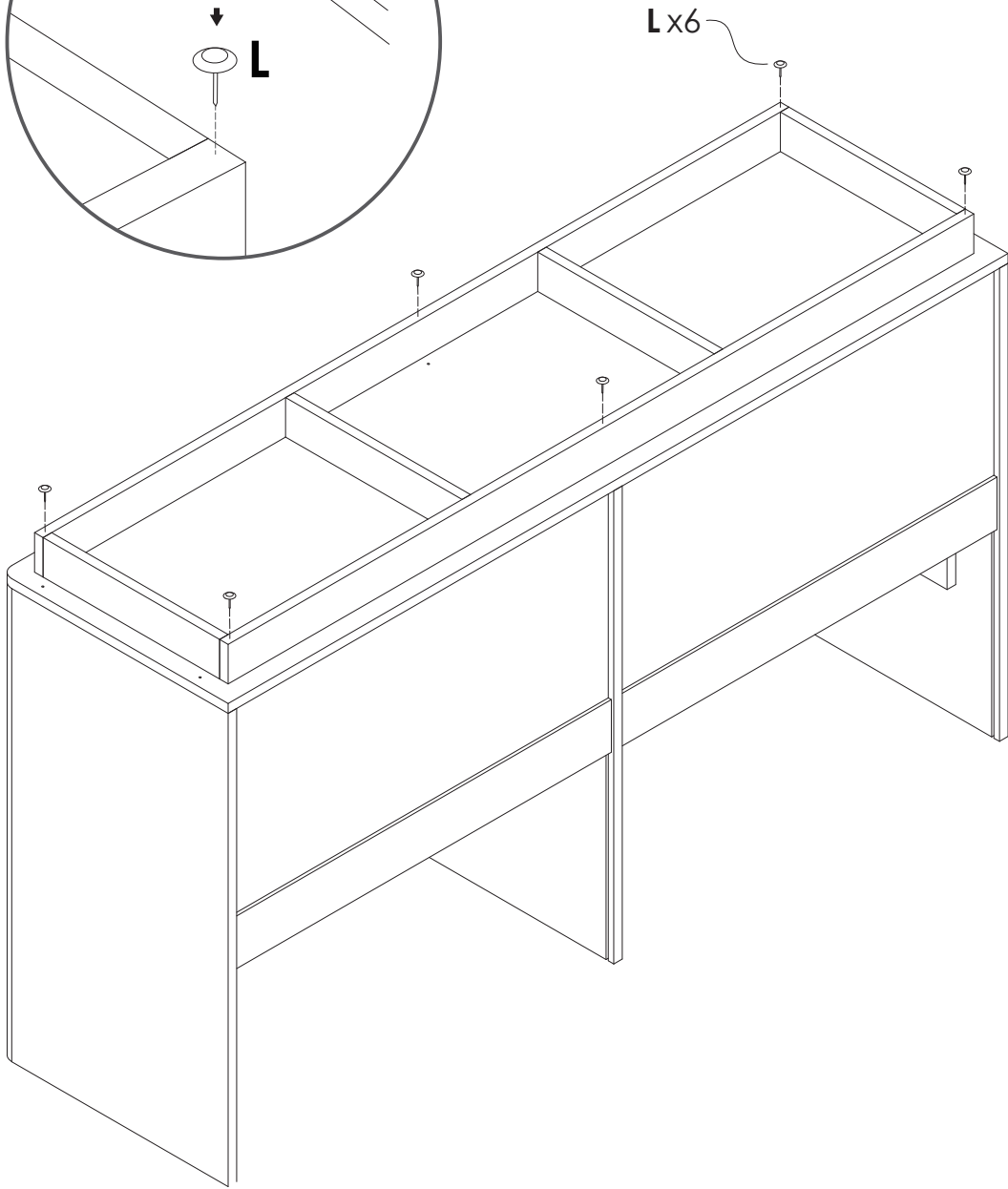
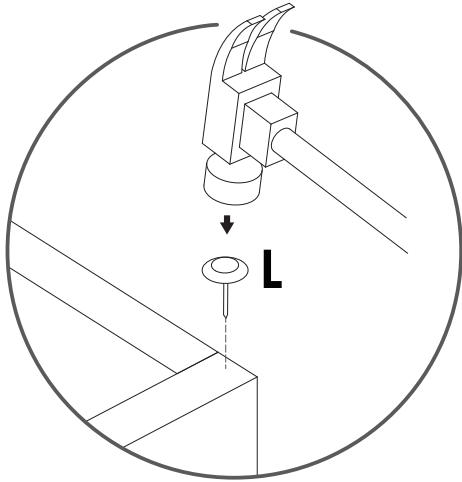
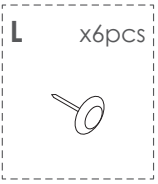

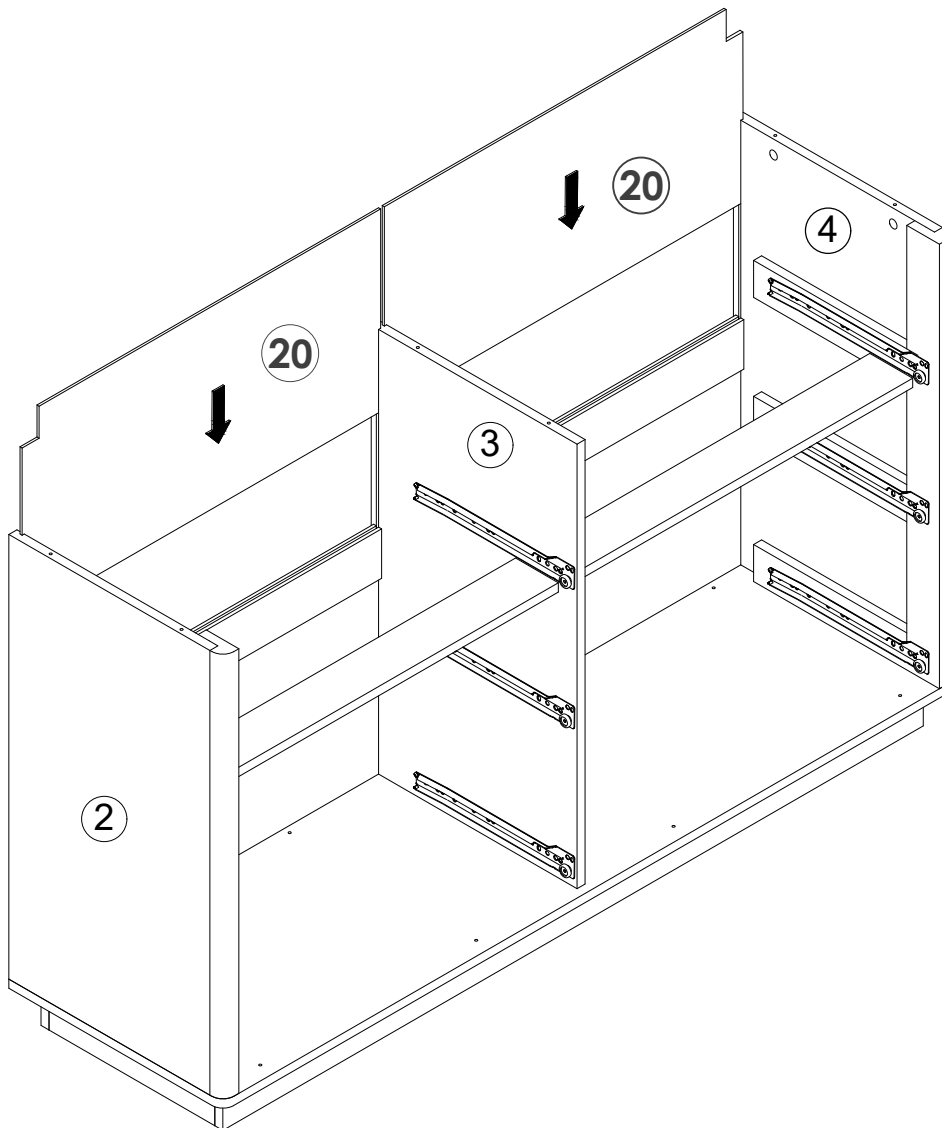

19

A x6pcs



M6*40mm

B x6pcs



M15*11mm

N x2pcs



N3



N4

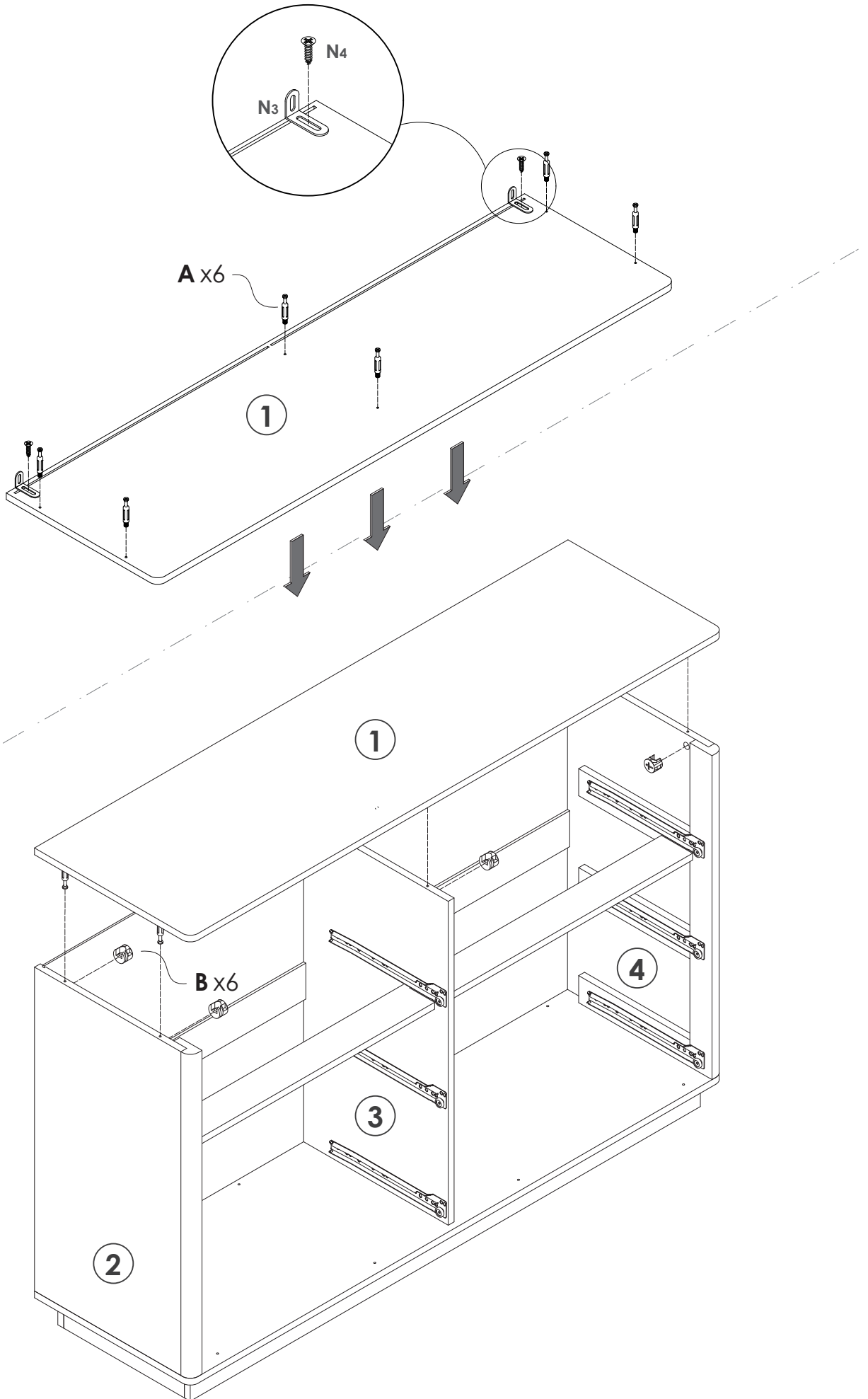

20

K x24pcs

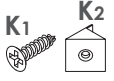

M3*16mm

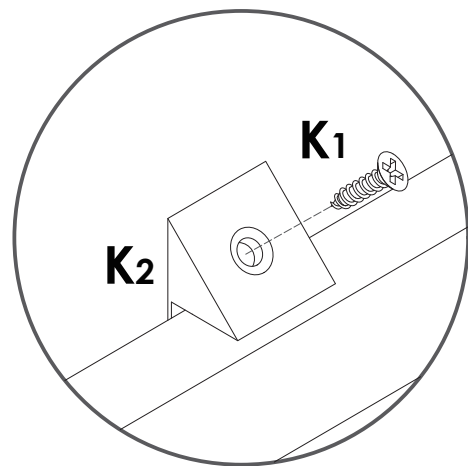
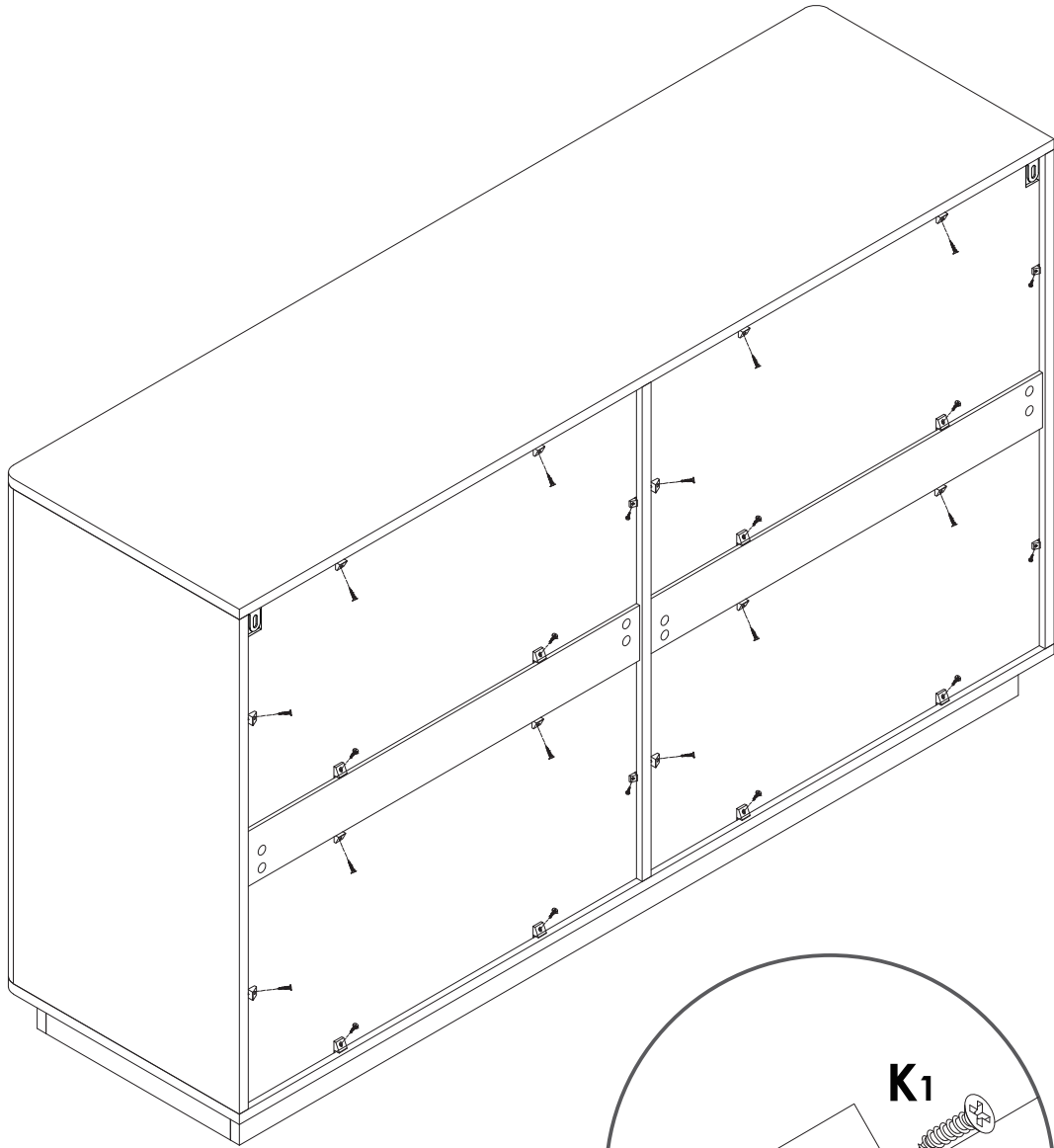

21

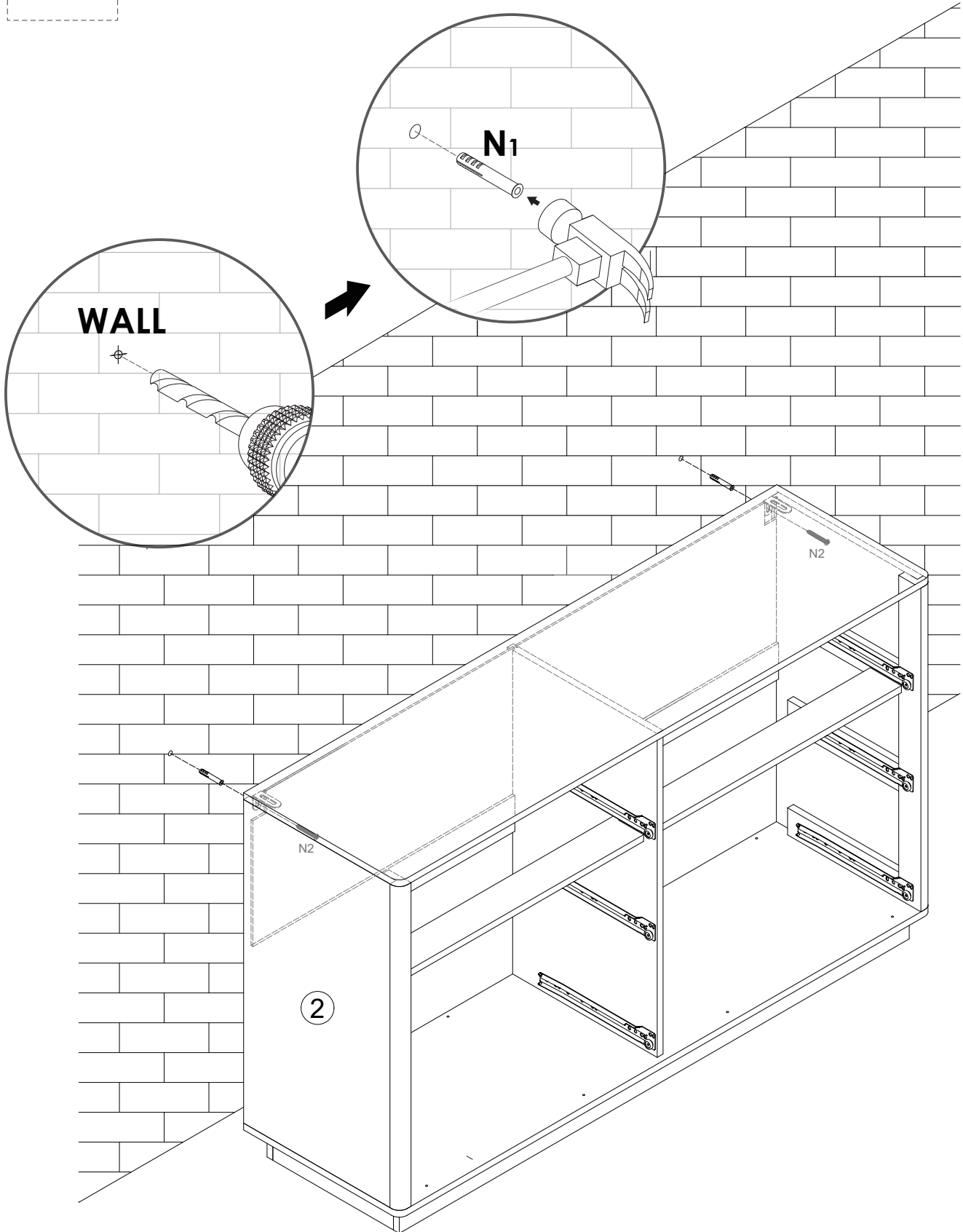
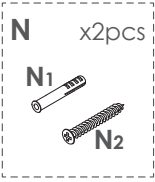

22

E x36pcs



M5*40mm

NOTE:
The holes here
face downwards

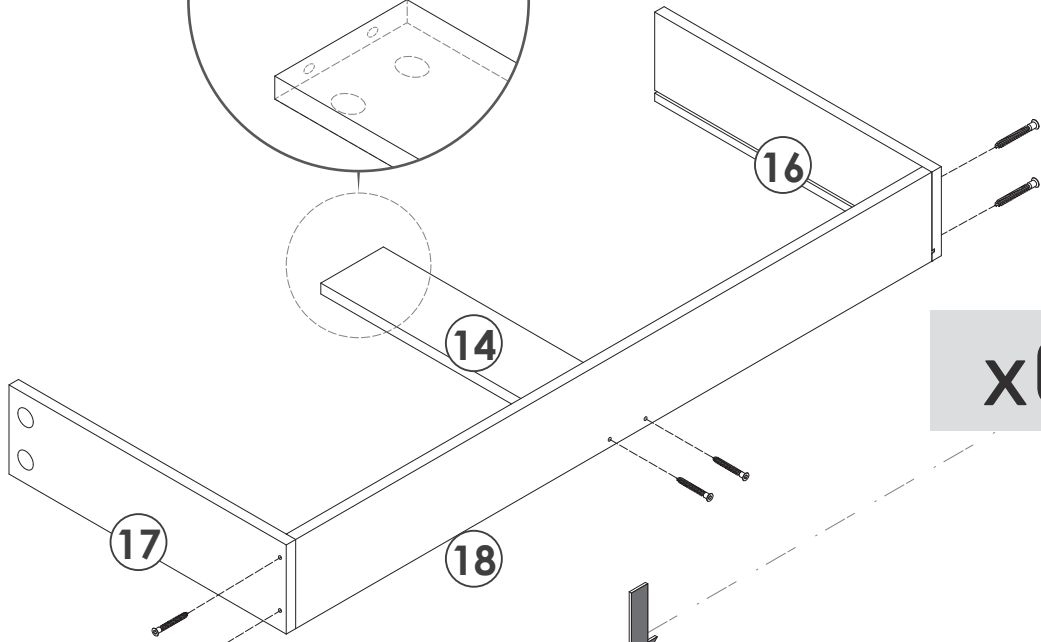
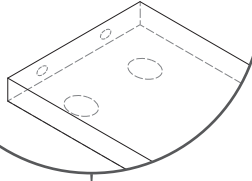

x6

E x6

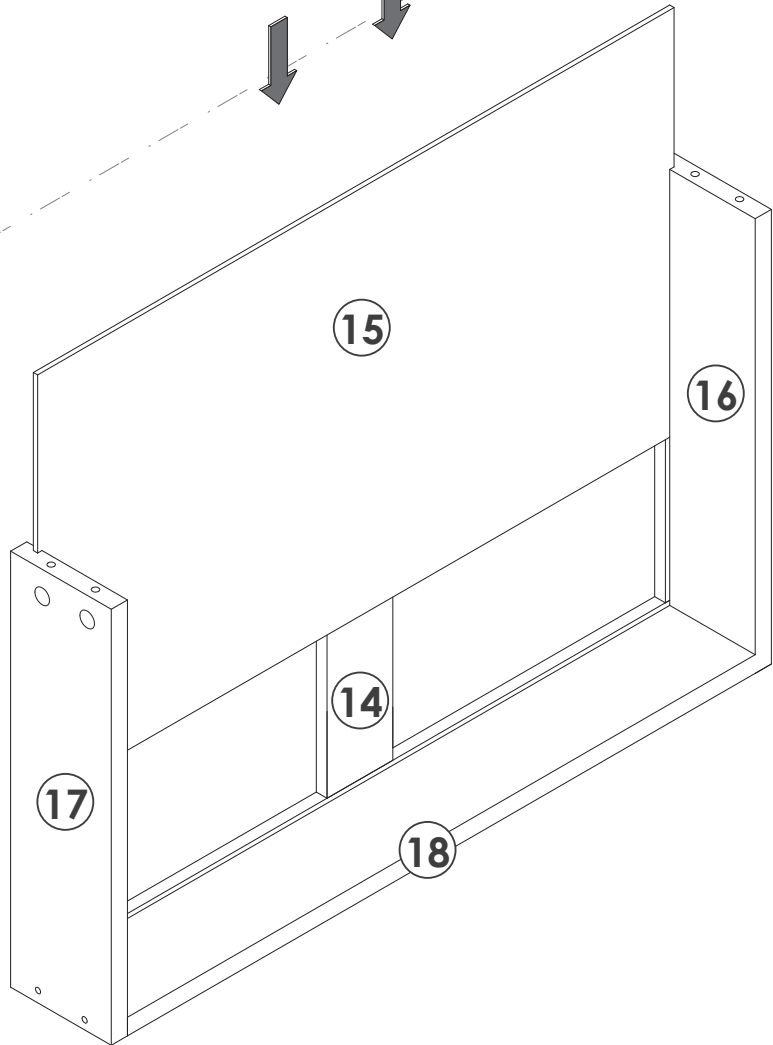

x6

23

P x18pcs



M6*40mm

H x3pcs



F x6pcs



M3*12mm

B x18pcs



M15*11mm

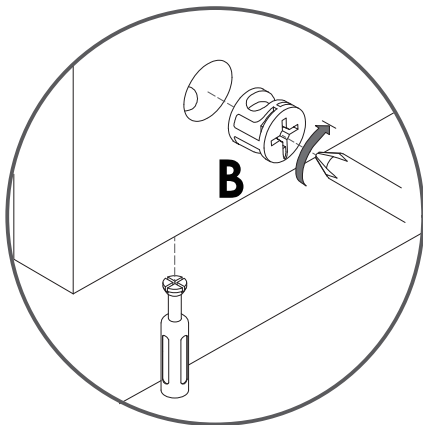
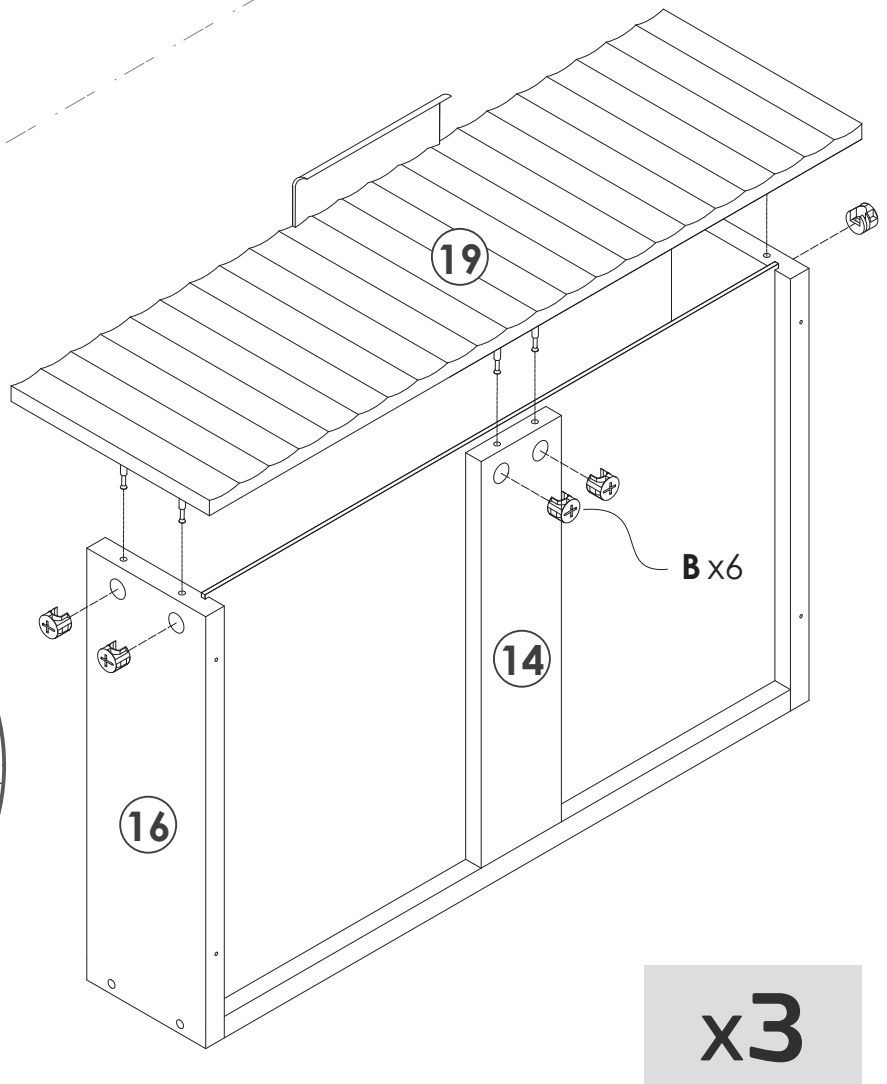
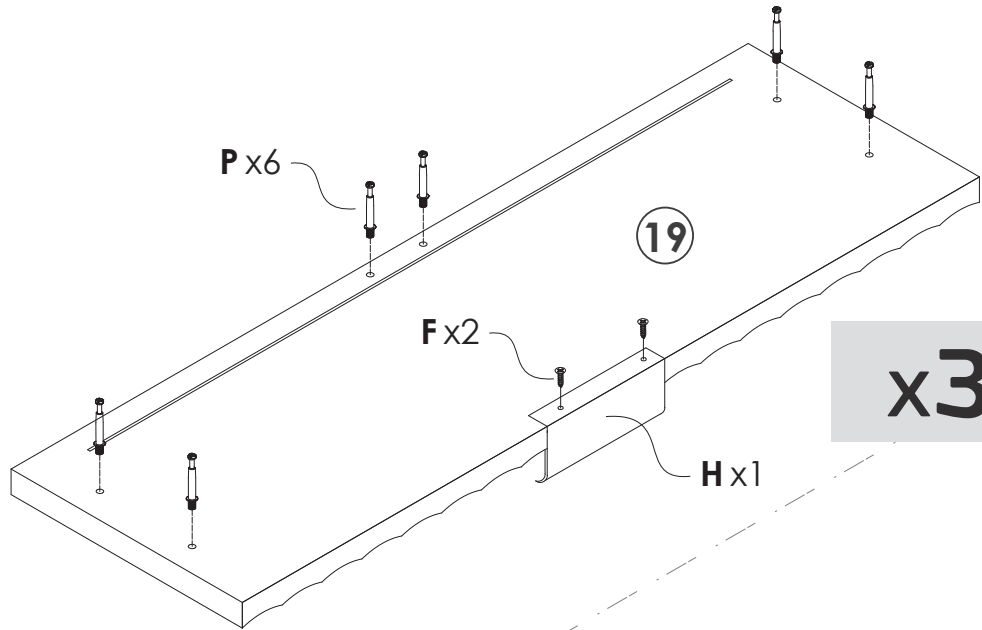

24

P x18pcs



M6*40mm

H x3pcs



F x6pcs



M3*12mm

B x18pcs



M15*11mm

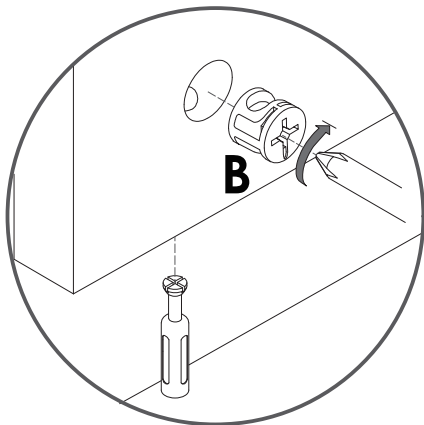
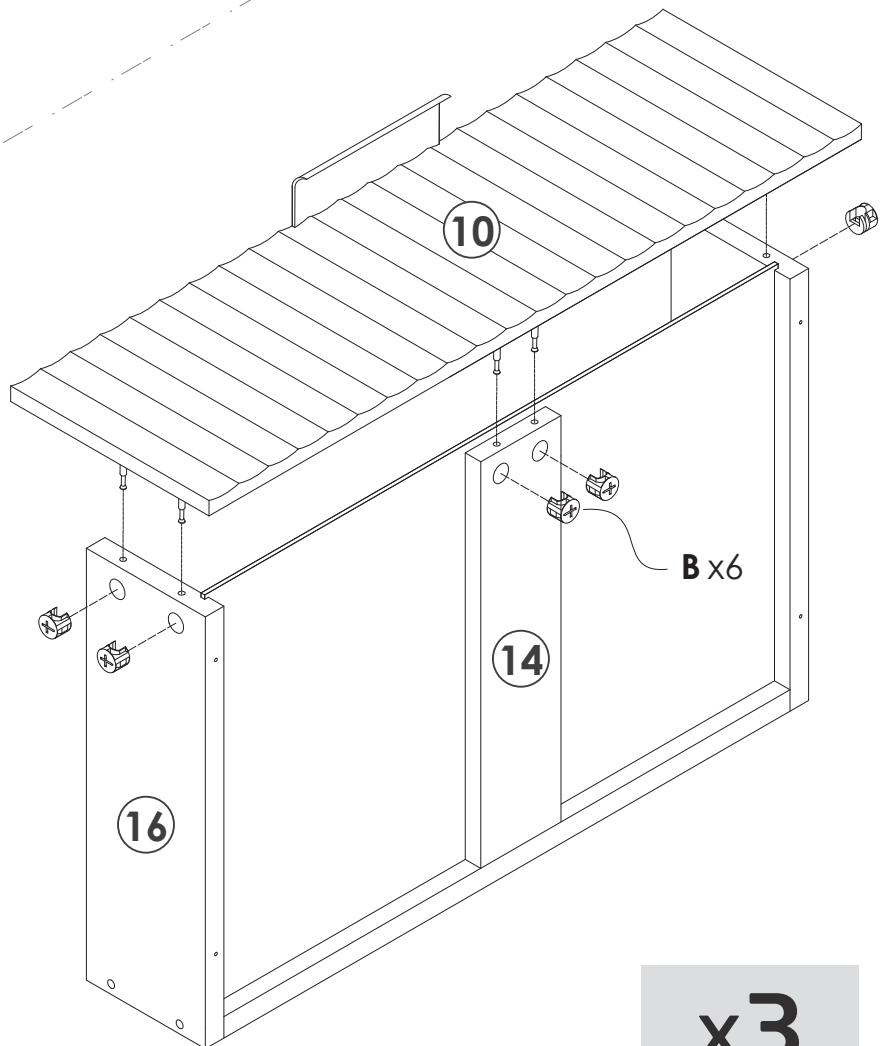
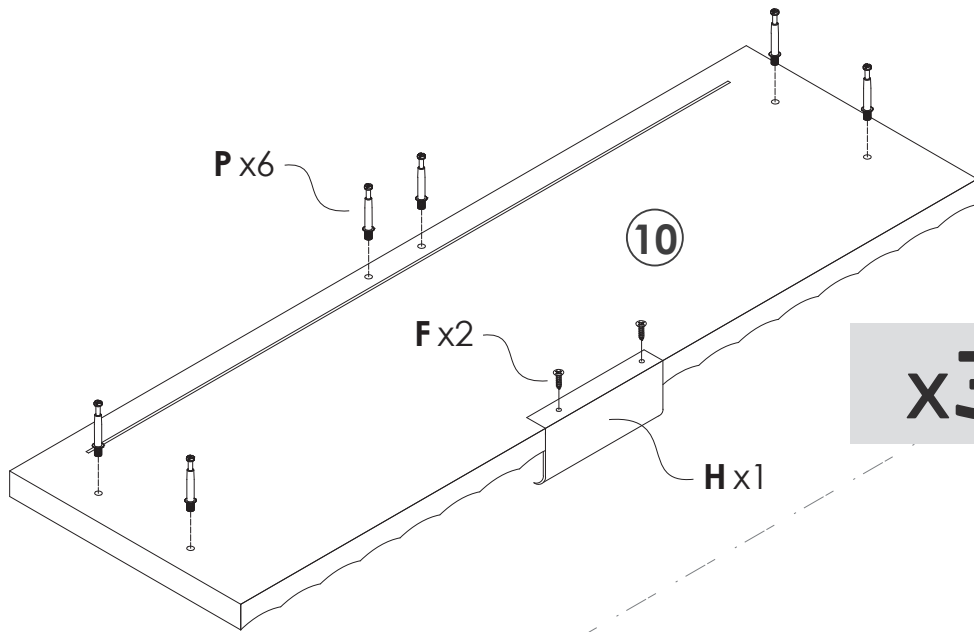

25

F x24pcs



M3*12mm

M x6pcs

DL DR

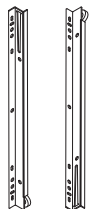

12 inches

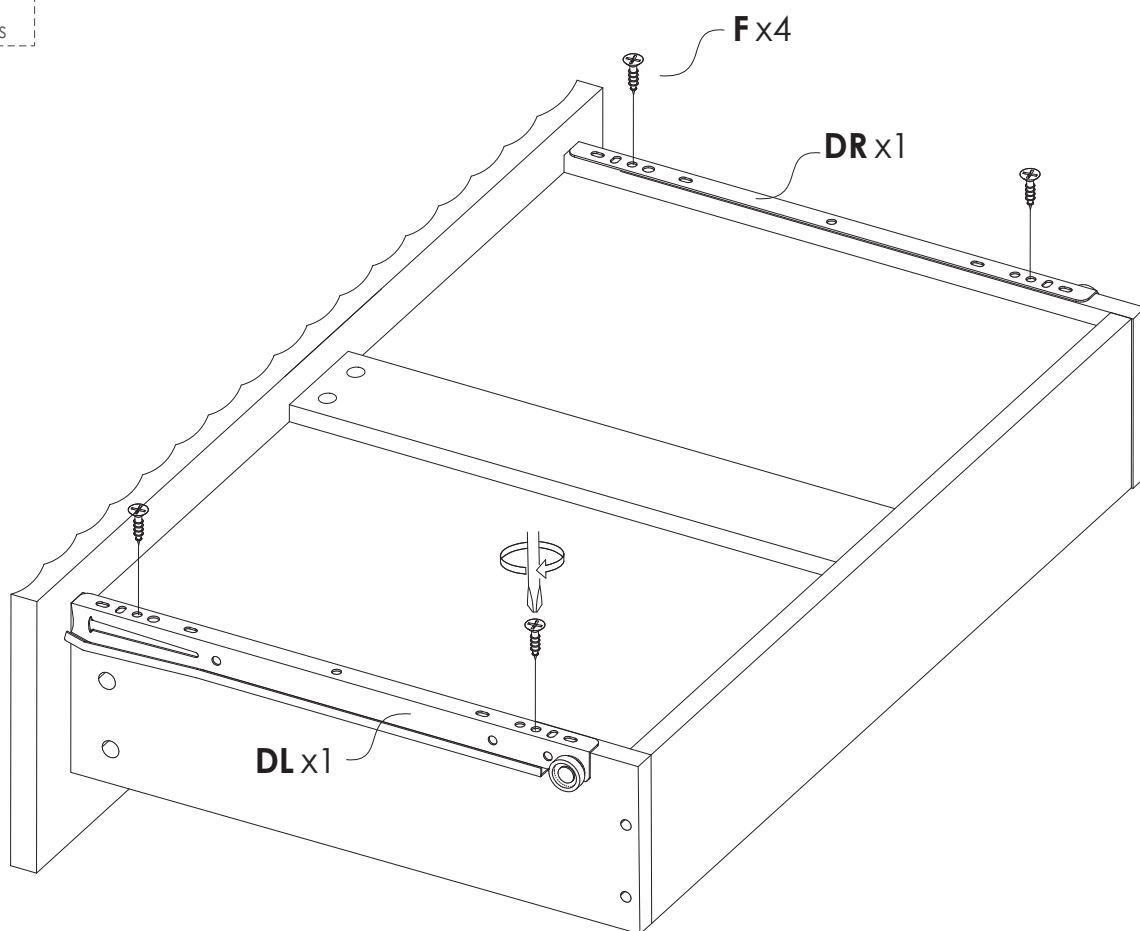

x6

26

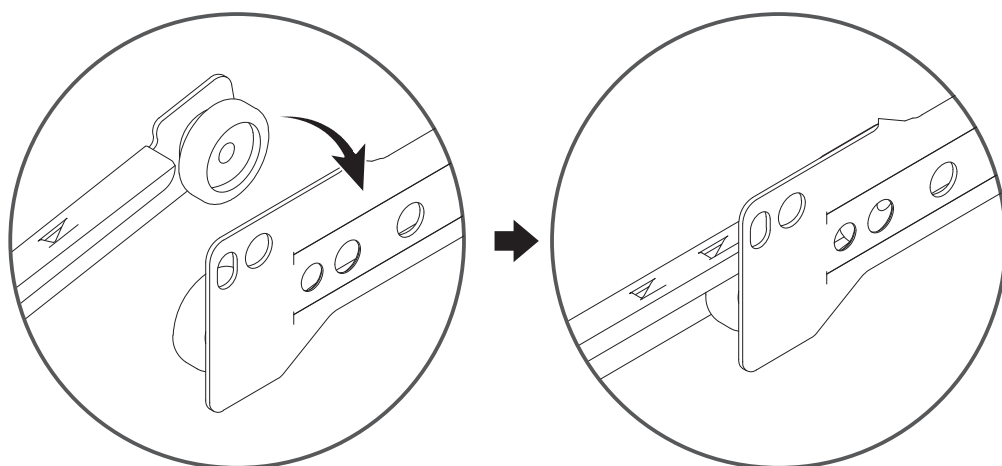
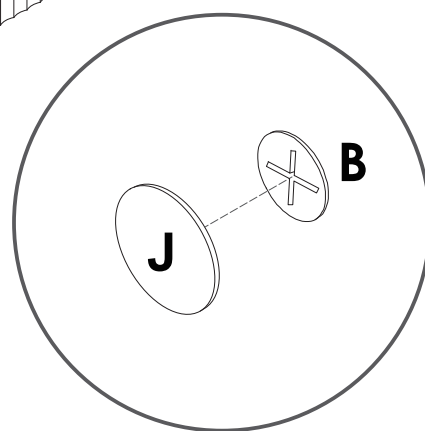
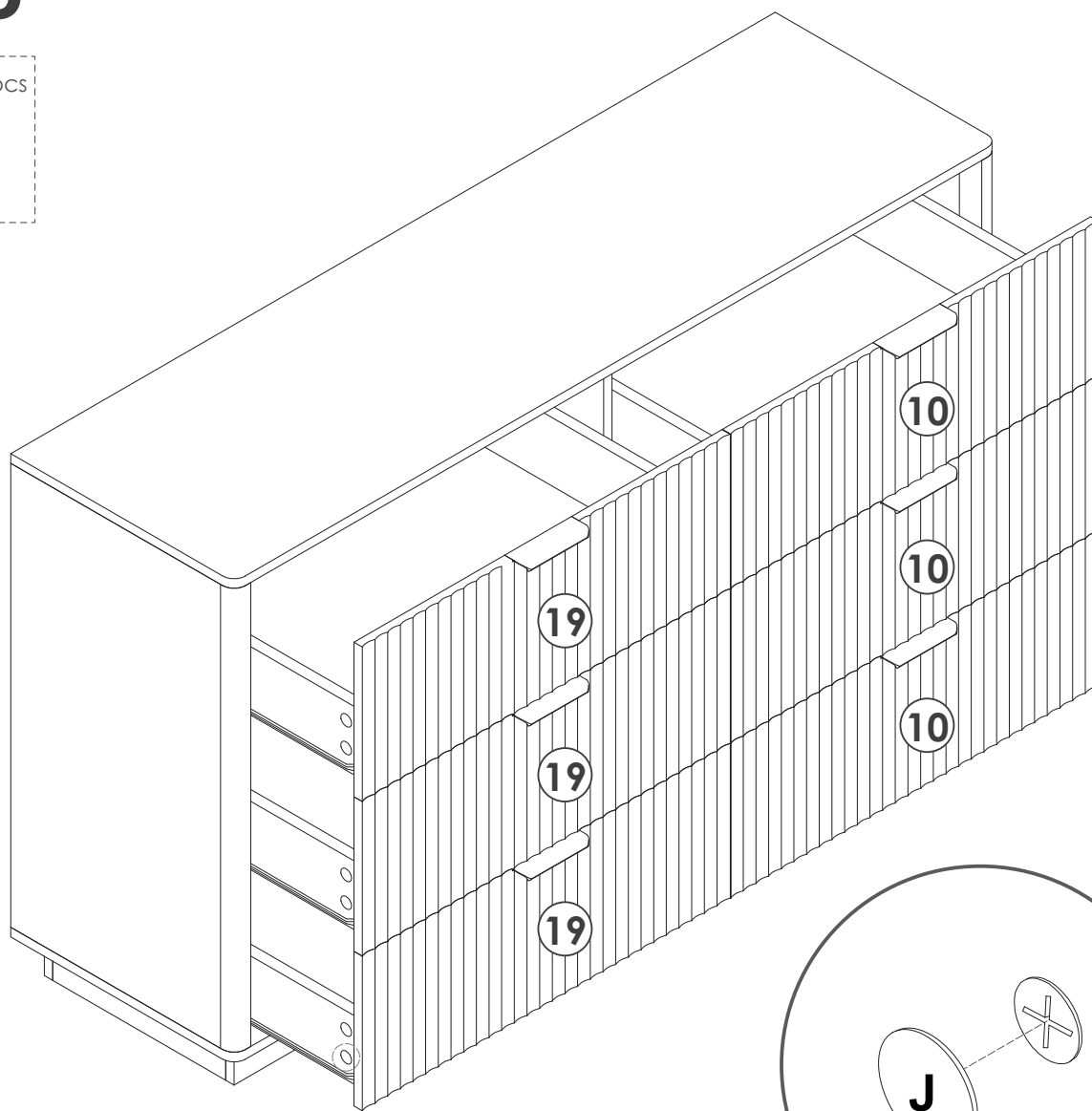
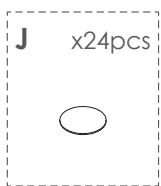

WARRANTY

We provide an **18-month** warranty on the product starting from the date of the original purchase. If the product has any manufacturing defect, please contact us through email with details about the problem. We will send you further information about the return or exchange.