

SIMPLIHOME®

Connaught / Hampshire / Somerset

Large Sideboard Buffet Storage Cabinet

Model # AXCCON53-XXX

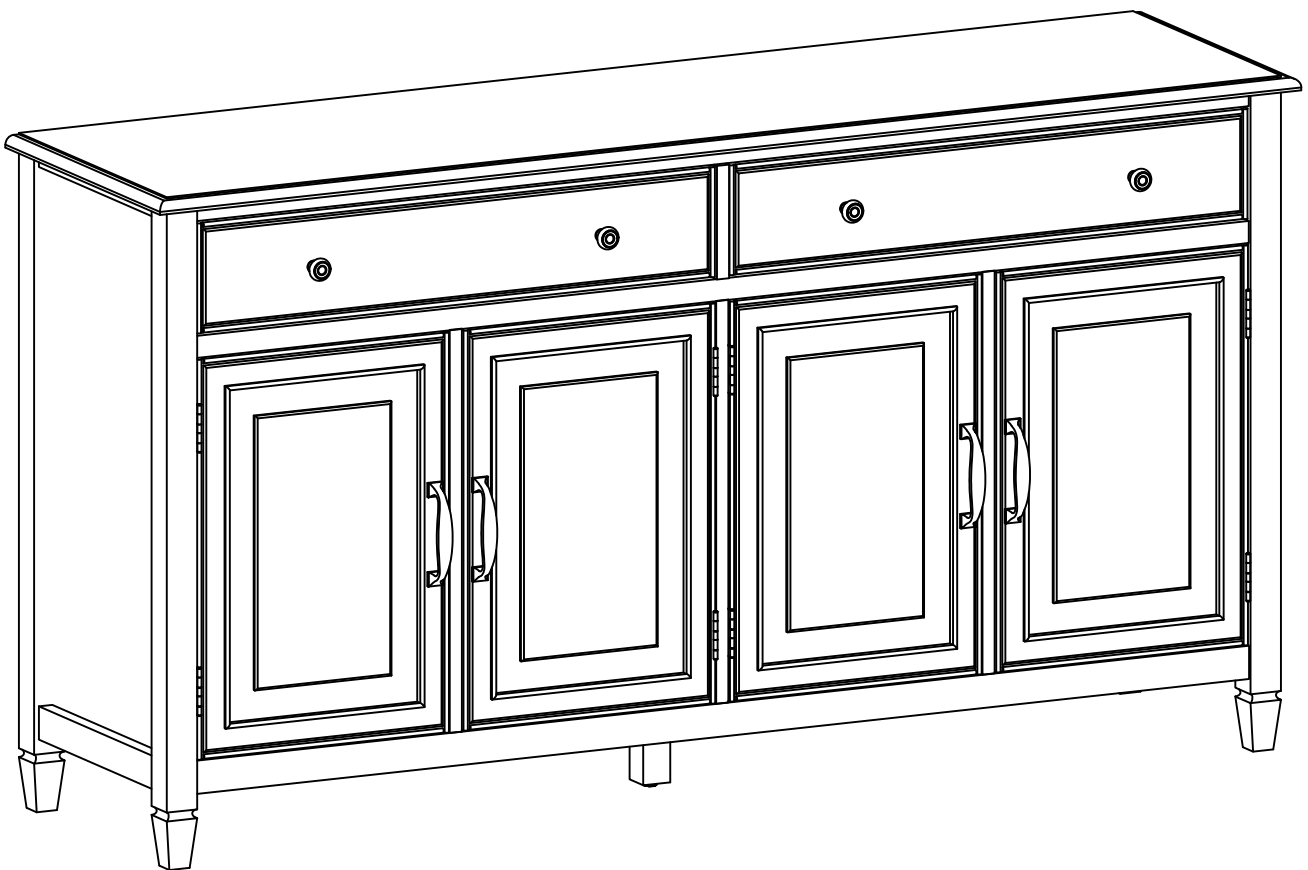

brooklyn + max™

WyndenHall™
HOME DECOR

SIMPLIHOME®

Claim Your Free Gift

Your opinion pays: Earn a gift!

Review your purchase and receive a gift.* It could be a gift card, Simpli Rewards points, or another special reward.



CLAIM YOUR REWARD NOW!

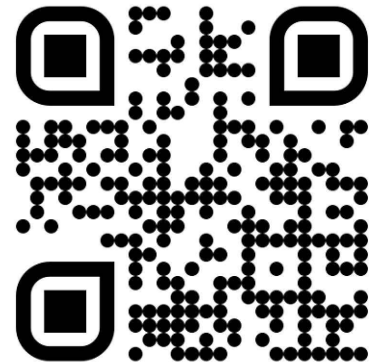

simpli-home.com/get-free-gift



**Offer valid for reviews posted within 30-days of purchase.*

SIMPLIHOME®

For Fastest Customer Service:



1. Open your phone's camera.
2. Point your phone's camera at the QR code to scan.
3. Click on the pop up.
4. You'll be taken to our customer service page.
5. Fill the form with your order information and issue.
6. Submit form.
7. A customer service associate will contact you.

Other ways to contact us...



Email Us

customerservice@simpli-home.com



Visit Us

Visit our site directly at
www.simpli-home.com



Call Us

1-866-518-0120
Monday to Friday
9am to 5pm EST

***If you've purchased from a retailer and you wish to return the product, please contact the retailer directly.**

IMPORTANT : Please read this manual carefully before beginning assembly of this product. Keep this manual for future reference.

Safety Information

CAUTION: Injuries and damage can occur from furniture tip over if product is not properly anchored to the wall. Use the Furniture Anti-Tipping Restraint provided with the product. Consult our assembly instructions for help.

If the Furniture Anti-Tipping Restraint kit is not in the box, please contact our customer service department in order to obtain another kit before using the furniture.

Identify all the parts and hardware. Do not discard of the packaging until you have checked that you have all of the parts and hardware required. Hardware package may have spare parts.

WARNING: This item contains small parts which can be swallowed by children and pets. Keep children and pets away during assembly. To avoid danger of suffocation, always keep plastic bags away from children and pets. We recommend that you assemble this unit on a carpeted floor to avoid scratches. If using power tools, set the tool to low torque to avoid damage.

May require 2 people for ease of assembly.

Care & Maintenance

This furniture is designed for indoor use.

Perhaps the greatest environmental damage to wood furniture comes from wide swings in relative humidity (RH) in our homes. Wood absorbs and desorbs water as relative humidity rises and falls, and in doing so it swells and shrinks. Making matters worse, it expands and contracts unequally along different grain directions. As humidity changes, the components of wooden objects are continually pushing and pulling against each other. This pressure often results in parts of furniture no longer fitting together closely or becoming distorted or breaking from their own internal stresses.

The response to relative humidity changes begins with determining the annual average RH for your particular space. Then try to keep the RH in the space where your furniture is as close to that average as possible, generally within about 10% up or down. De-humidify in the summer and humidify in the winter.

Be aware that raising the temperature lowers the humidity and vice versa. Thus, modern heating systems, which can drive down interior RH in the winter, almost invariably cause problems for furniture. To counteract their effect, you can either modify the RH by keeping furniture containing spaces cooler in the winter or most importantly, have a good working humidifier for your home. A humidistat automatically works to balance the humidity in your home so it is constant. Dry indoor air can suck enough moisture from its surroundings to do permanent damage to wood, causing it to crack or split.

Remember, that not all woods are created equal. Two factors that help determine how rapidly a wood will lose moisture are pore size and surface hardness. A piece made from a dense and hard wood will dry less rapidly than pieces made from softer woods.

Furniture that is sealed and lacquered will lose moisture more slowly than an unfinished piece while pieces with veneer finishes are not only stronger but lose moisture more slowly than other finishes.

To help protect your wood furniture, take these steps:

- Use a humidifier, preferably one with an automatic control system that can sense the humidity level and adjust itself accordingly
- Don't over-humidify; that can damage wood by causing it to expand and contract
- Keep furniture out of direct sunlight, which can cause it to dry out, crack and warp
- If you can avoid it, don't put furniture near heating vents; if you can't, keep the item 3 to 4 inches away from the wall, giving the heat and air space to circulate
- Dust with soft dry cloth
- Do not use liquid or aerosol products
- To avoid marking, do not place rubber on surface (foot pads, etc.)
- For soil build-up, wipe with damp cloth & dry
- Do not use abrasive cleaners

Pre-Assembly Information

Part Description

A

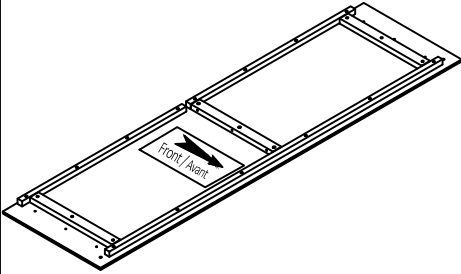

TOP
QTY 1

BL

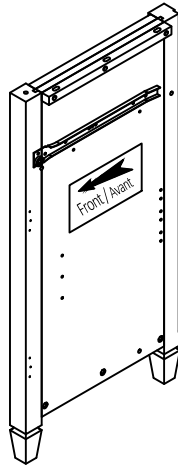

LEFT SIDE
QTY 1

BR

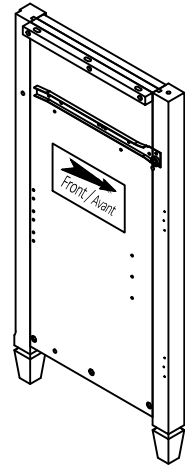

RIGHT SIDE
QTY 1

C

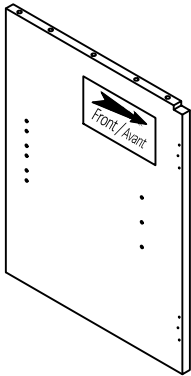

MIDDLE LARGE DIVIDER
QTY 1

DL

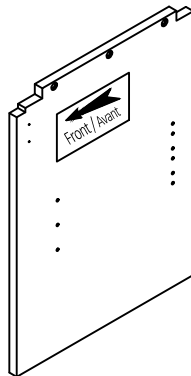

LEFT LARGE DIVIDER
QTY 1

DR

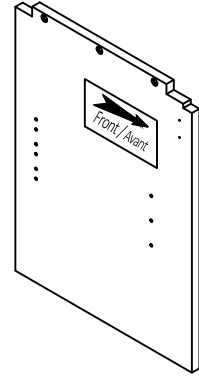

RIGHT LARGE DIVIDER
QTY 1

E

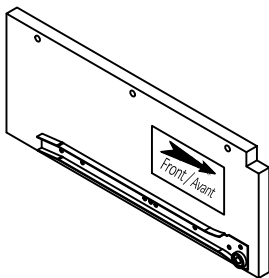

SMALL DIVIDER
QTY 1

F

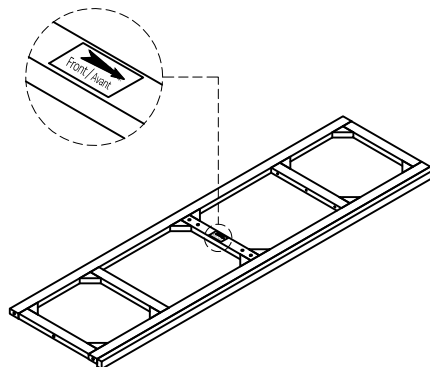

TOP FRAME
QTY 1

G

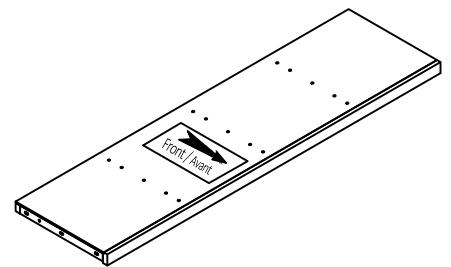

BOTTOM FRAME
QTY 1

Pre-Assembly Information

Part Description

H

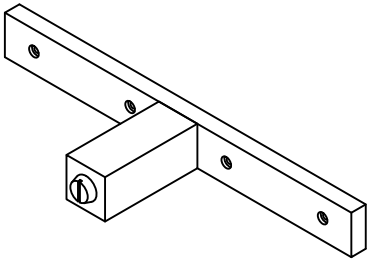

BOTTOM SUPPORT LEG
QTY 1

IL

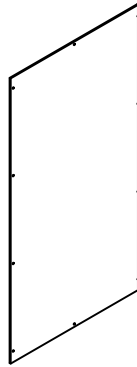

LEFT BACK PANEL
QTY 1

IR

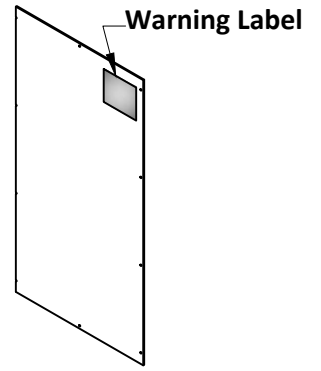

RIGHT BACK PANEL
QTY 1

I

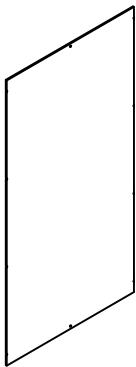

MIDDLE BACK PANEL
QTY 2

J

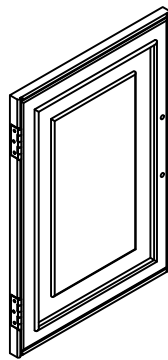

DOOR
QTY 4

K

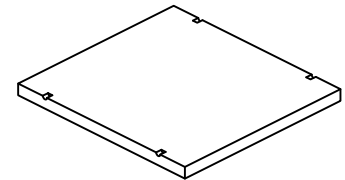

SHELF
QTY 4

L

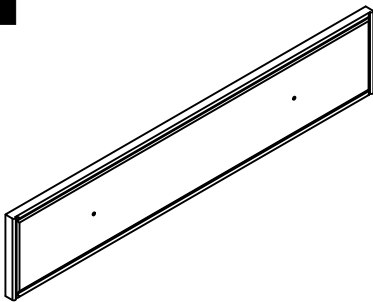

DRAWER FRONT
QTY 2

ML

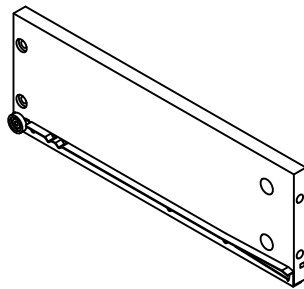

LEFT DRAWER SIDE
QTY 2

MR

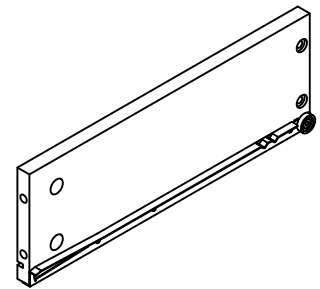

RIGHT DRAWER SIDE
QTY 2

N

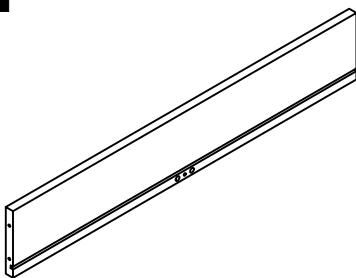

DRAWER BACK
QTY 2

O

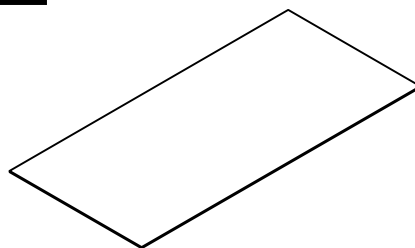

DRAWER BOTTOM
QTY 2



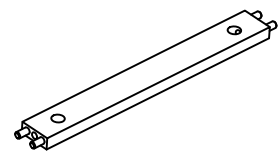

P

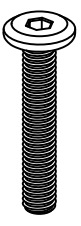
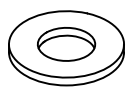
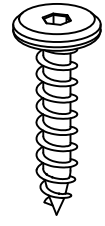
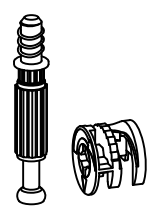
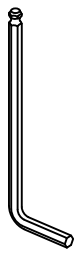
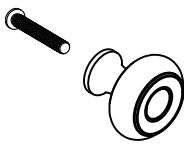
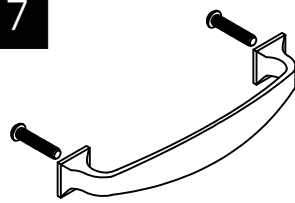
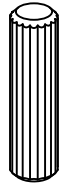
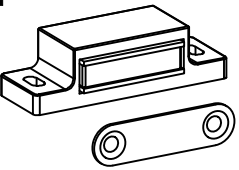
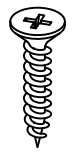
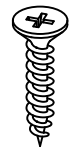
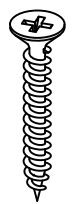
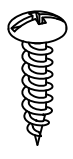
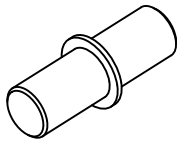
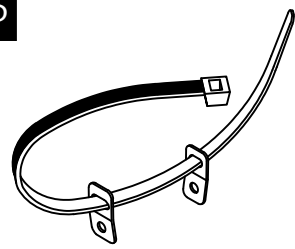

SUPPORT DRAWER BOTTOM
QTY 2

Pre-Assembly Information

Hardware Description

<p>1</p>  <p>ALLEN KEY BOLT M6 X 35mm QTY 12</p>	<p>2</p>  <p>WASHER Ø6.5 / Ø16 X 1mm QTY 12</p>	<p>3</p>  <p>ALLEN KEY SCREW M6 X 30mm QTY 32</p>	<p>4</p>  <p>CAM LOCK PIN CAM LOCK QTY 15 SETS</p>
<p>5</p>  <p>ALLEN KEY QTY 1</p>	<p>6</p>  <p>HANDLE M4 X 30mm - QTY 4 QTY 4 SETS</p>	<p>7</p>  <p>HANDLE M4 X 15mm - QTY 8 QTY 4 SETS</p>	<p>8</p>  <p>WOOD DOWEL Ø8 X 30mm QTY 18</p>
<p>9</p>  <p>MAGNET AND PLATE QTY 4 SETS</p>	<p>10</p>  <p>PHILLIPS SCREW M3 X 15mm QTY 16</p>	<p>11</p>  <p>PHILLIPS SCREW M3 X 15mm QTY 24</p>	<p>12</p>  <p>PHILLIPS SCREW M4 X 30mm QTY 4</p>
<p>13</p>  <p>PHILLIPS SCREW ROUND HEAD M4 X 15mm QTY 28</p>	<p>14</p>  <p>SHELF SUPPORT QTY 24</p>	<p>15</p>  <p>FURNITURE TIP OVER RESTRAINT QTY 1 SET</p> <ul style="list-style-type: none"> a.  M4 X 25mm - QTY 2 (1 is extra) b.  M4 X 15mm - QTY 1 c.  M4 X 25mm - QTY 1 	

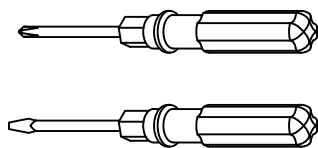

Required -
Flathead screwdriver
Phillips screwdriver
Rubber mallet
Not Included

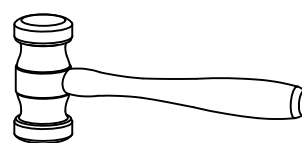

Components - Key Diagram

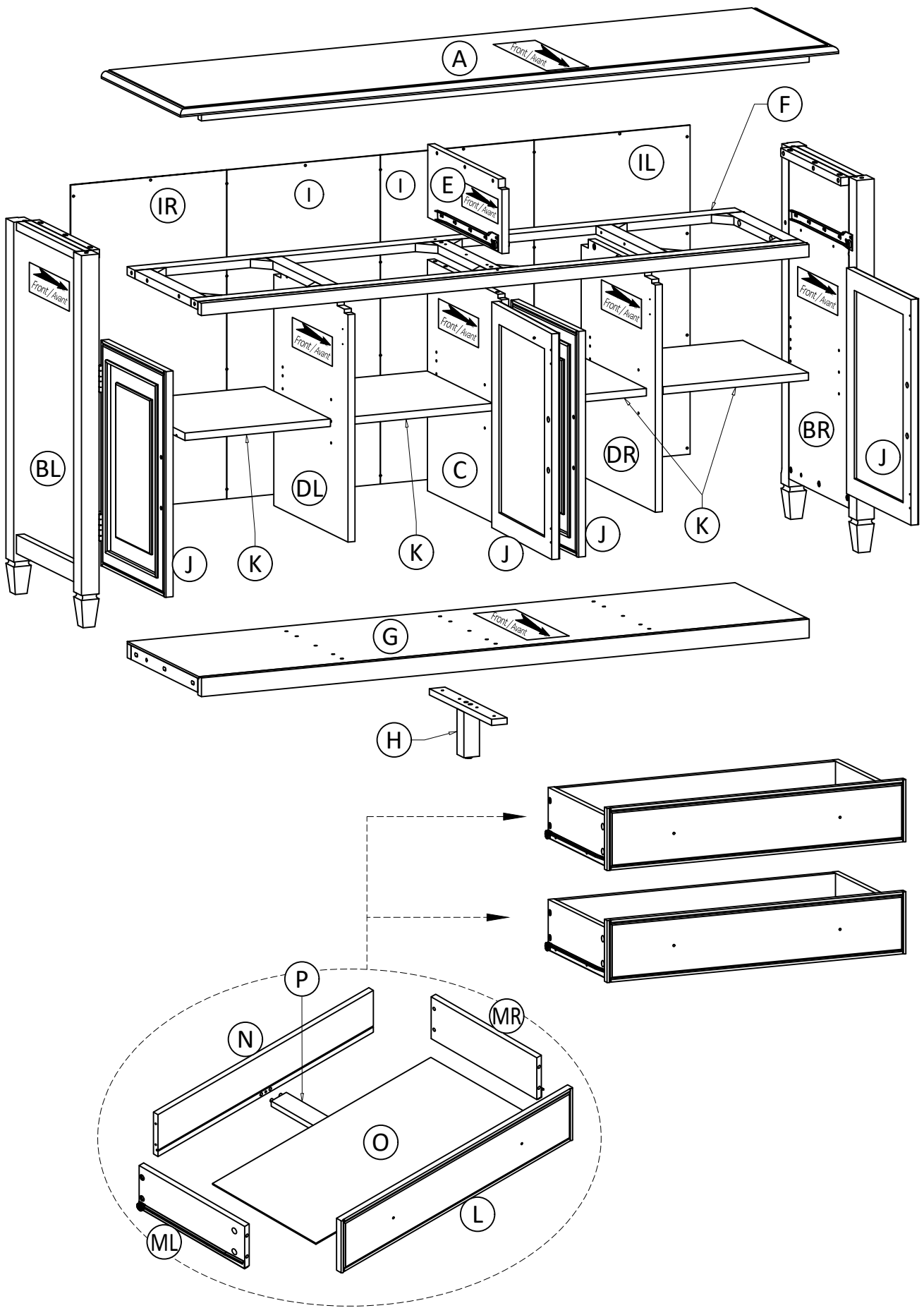

Components - Key Diagram

Step 1

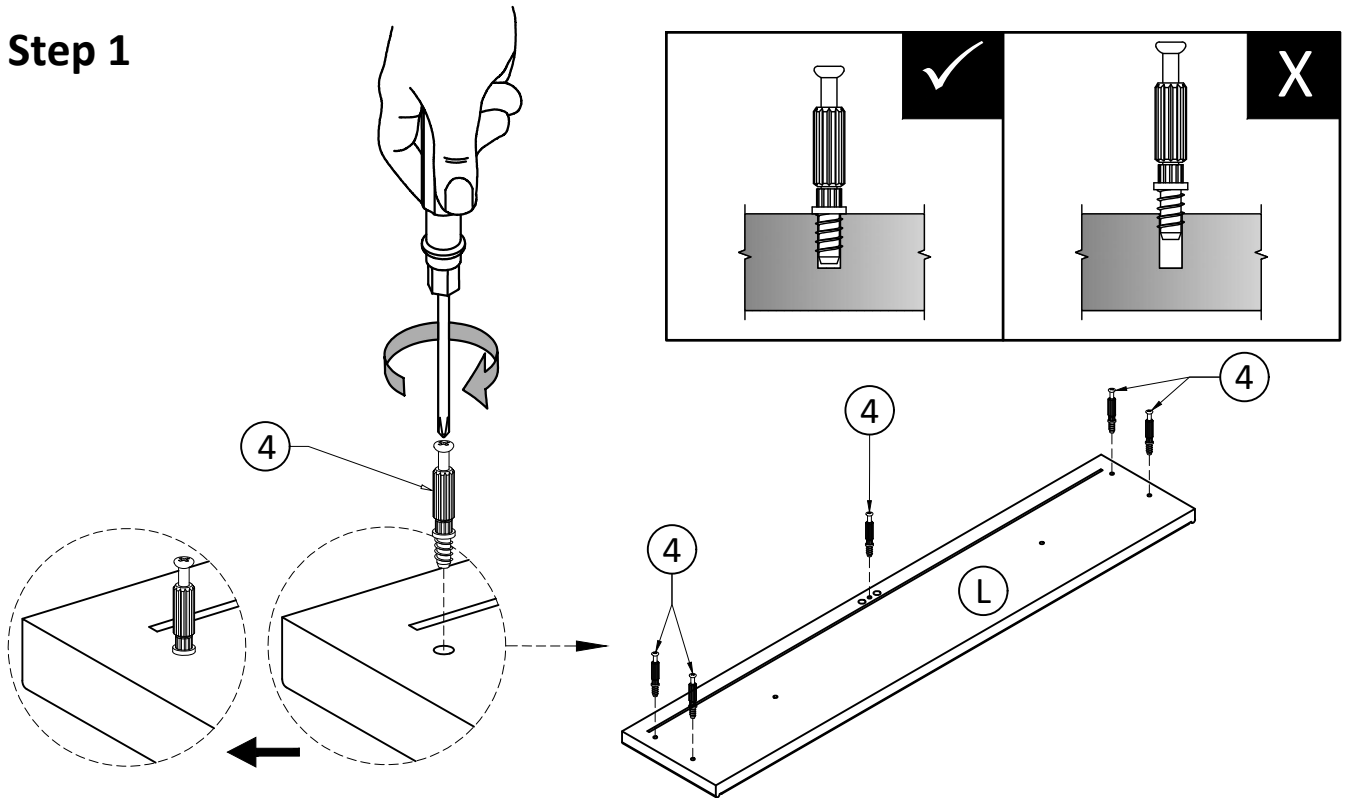

1. Attach five Cam Lock Pins (4) into pre-drilled holes on back of Drawer Front (L).
2. Use Phillips screwdriver to secure Cam Lock Pins. Do not over-tighten.

Step 2

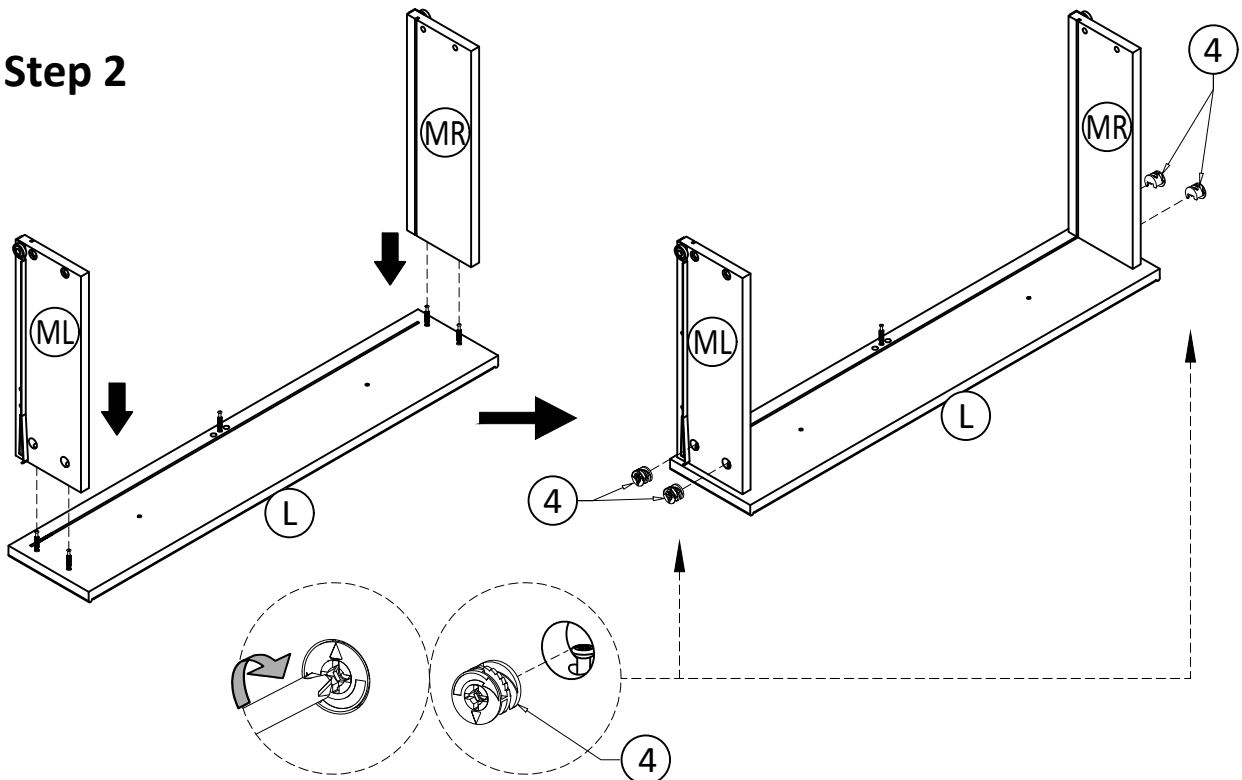

1. Align Cam Lock Pins with guide holes and attach Drawer Sides (ML, MR).
2. Insert two Cam Locks (4) into guided holes on each Drawer Side (ML, MR).
3. Use Phillips screwdriver to secure Cam Locks. Do not over-tighten.

Components - Key Diagram

Step 3

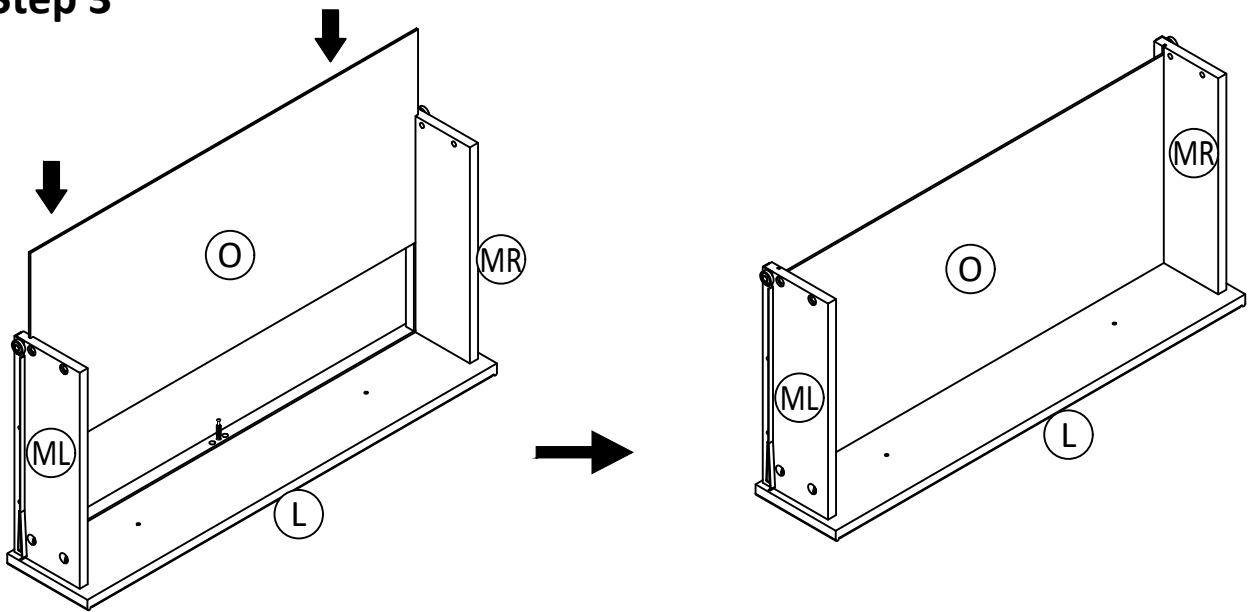

1. Slide Drawer Bottom (O) firmly into slots on Drawer Sides (ML, MR) and Drawer Front (L).

Step 4

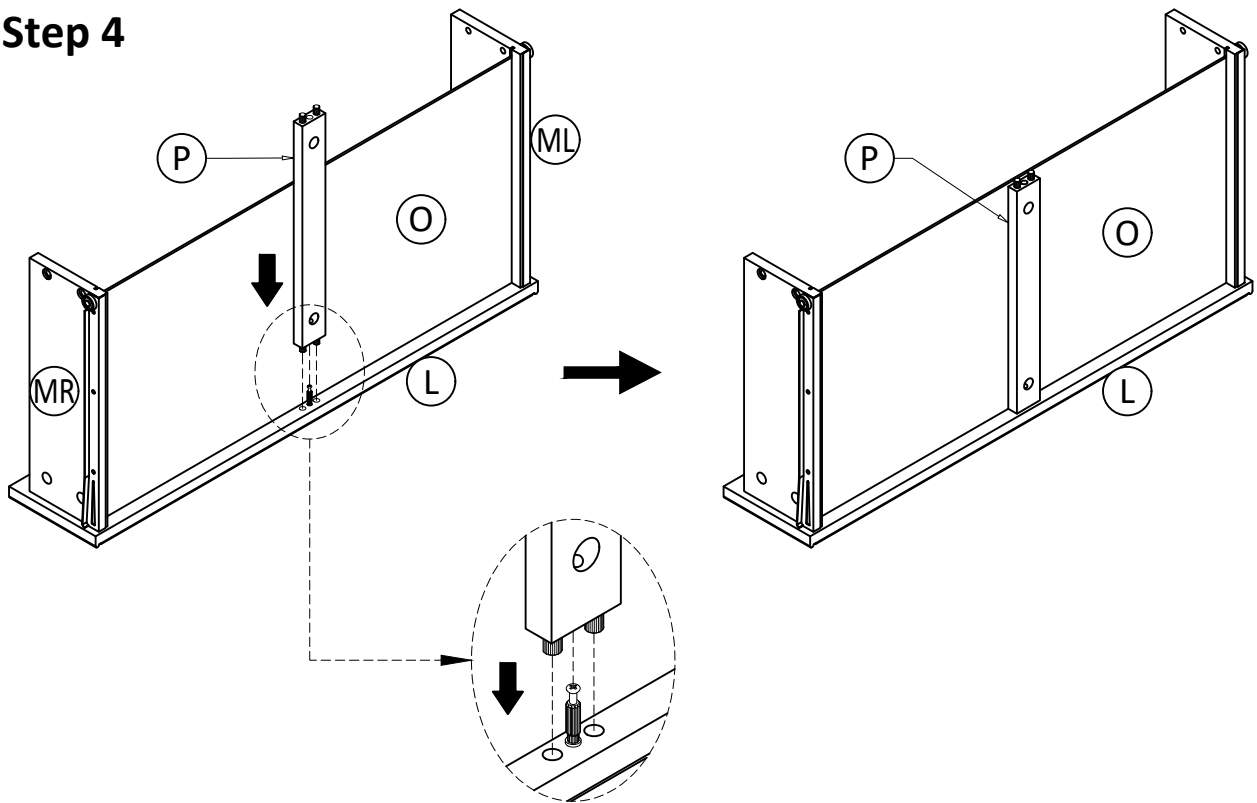

1. Align Cam Lock Pins and Wood Dowels with guide holes and attach Support Drawer Bottom (P) to Drawer Front (L).

Components - Key Diagram

Step 5

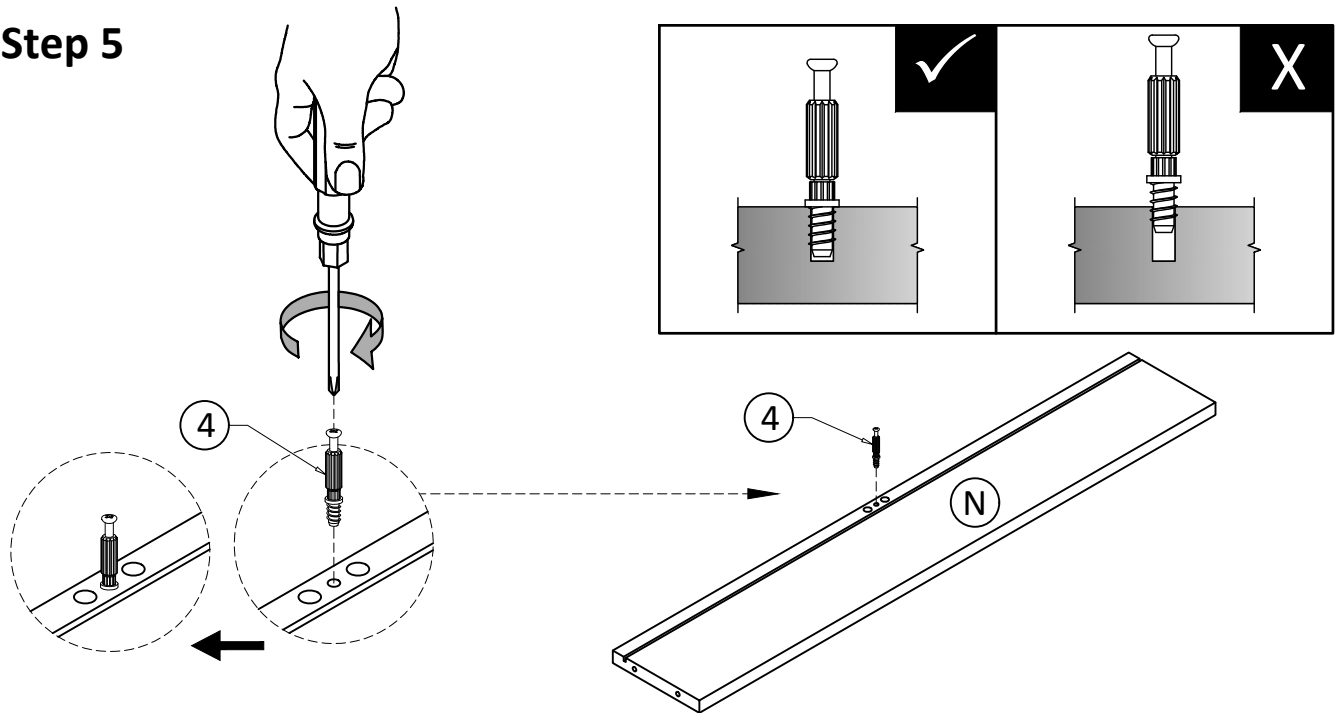

1. Attach one Cam Lock Pin (4) into pre-drilled holes on Drawer Back (N).
2. Use Phillips screwdriver to secure Cam Lock Pins. Do not over-tighten.

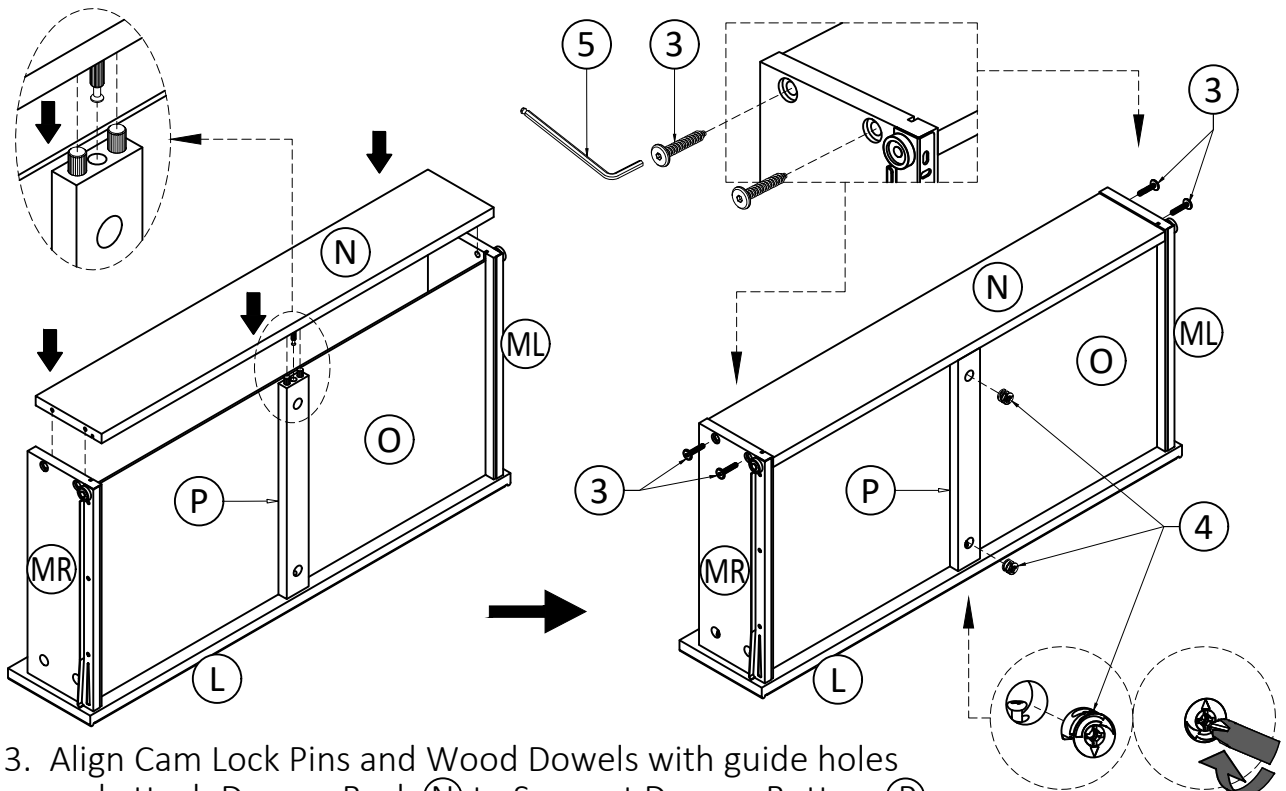

3. Align Cam Lock Pins and Wood Dowels with guide holes and attach Drawer Back (N) to Support Drawer Bottom (P) and align Drawer Back (N) with Drawer Bottom (O) and press firmly into slot.
4. Attach Drawer Back using two Allen Key Screws (3) through guide holes on each Drawer Side (ML, MR).
5. Use Allen Key (5) to tighten Screws. Do not over-tighten.
6. Insert two Cam Locks (4) into guided holes on Support Drawer Bottom (P).
7. Use Phillips screwdriver to secure Cam Locks. Do not over-tighten.

Components - Key Diagram

Step 6

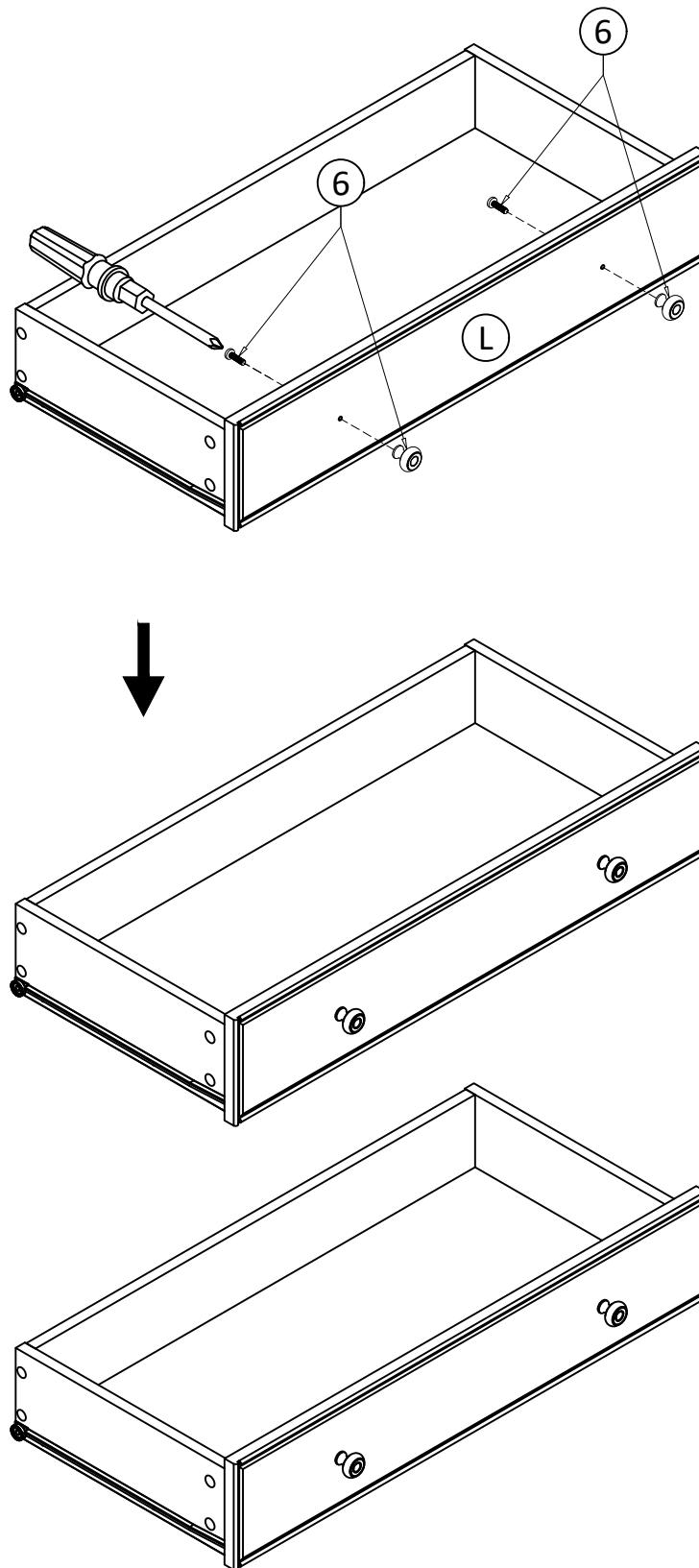

1. Use Phillips screwdriver to attach Handles (6) to Drawer Front (L).

Repeat Step 1-5 for the second drawer.

Assembly

Step 7

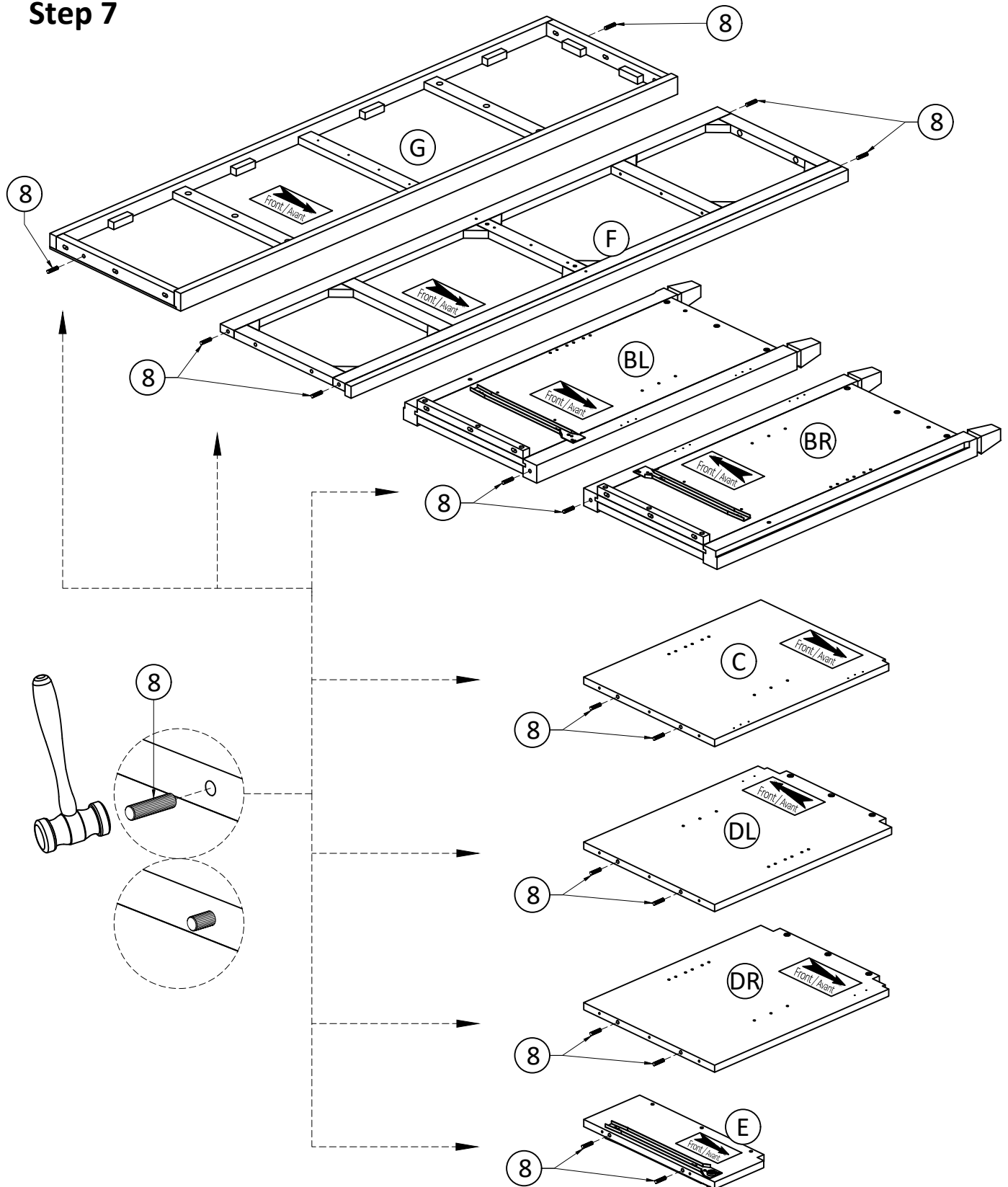

1. Insert Wood Dowels (8) into guide holes on Sides (BL), (BR), Dividers (C), (DL), (DR), (E), Top Frame (F) and Bottom Frame (G).
2. Use rubber mallet to tap Dowels (8) into bottom of holes securely.
1/3 length of Dowels should be exposed.

Assembly

Step 8

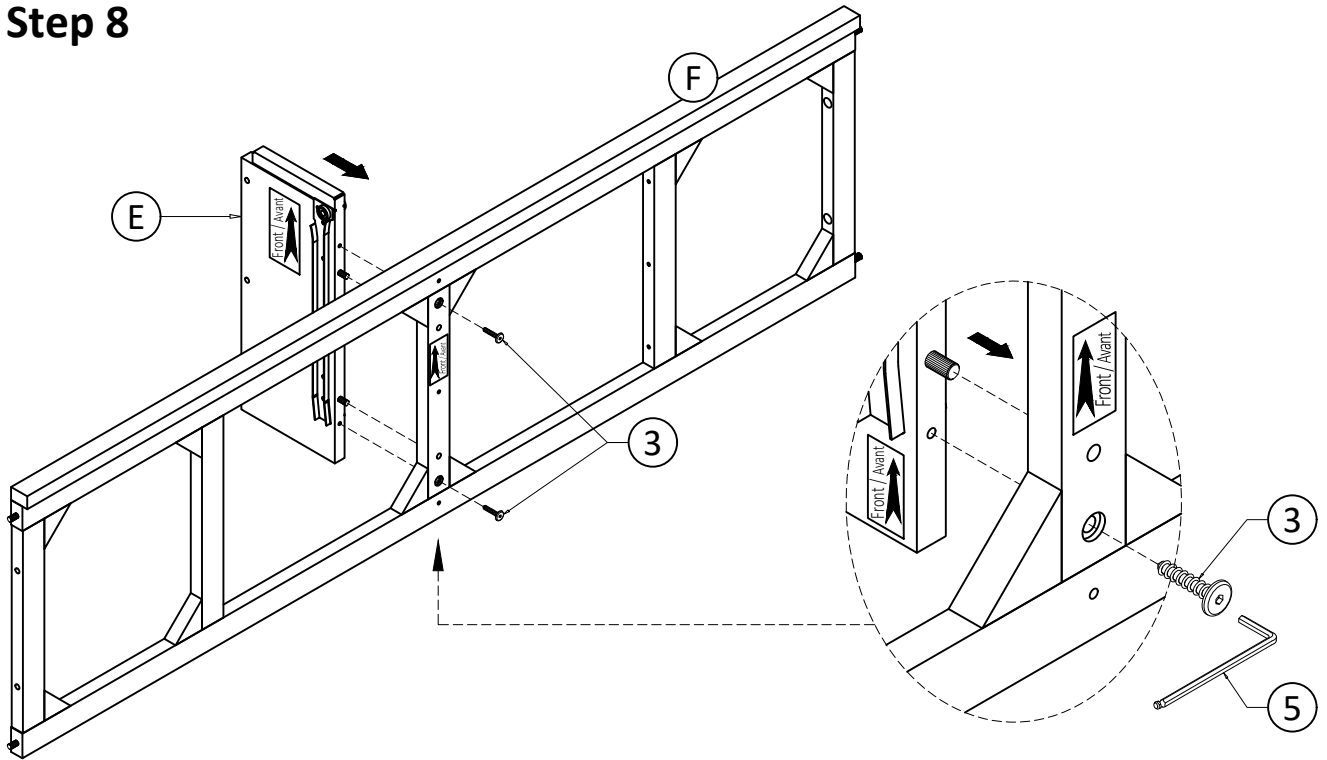

1. Attach Divider (E) to Top Frame (F) using two Allen Key Screws (3) through guide holes.
2. Use Allen Key (5) to tighten screws. Do not over-tighten.

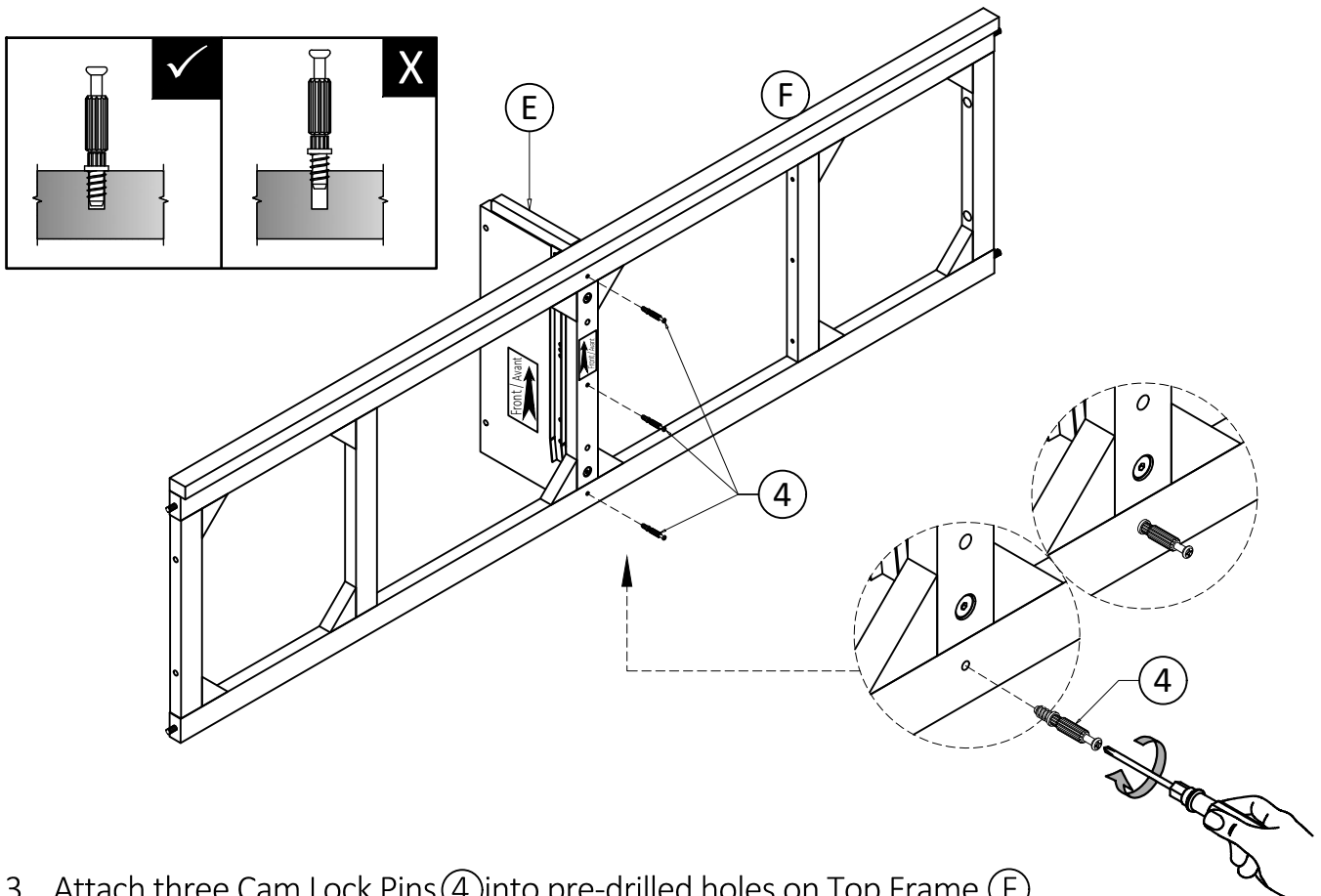

3. Attach three Cam Lock Pins (4) into pre-drilled holes on Top Frame (F).
4. Use Phillips screwdriver to secure Cam Lock Pins. Do not over-tighten.

Assembly

Step 9

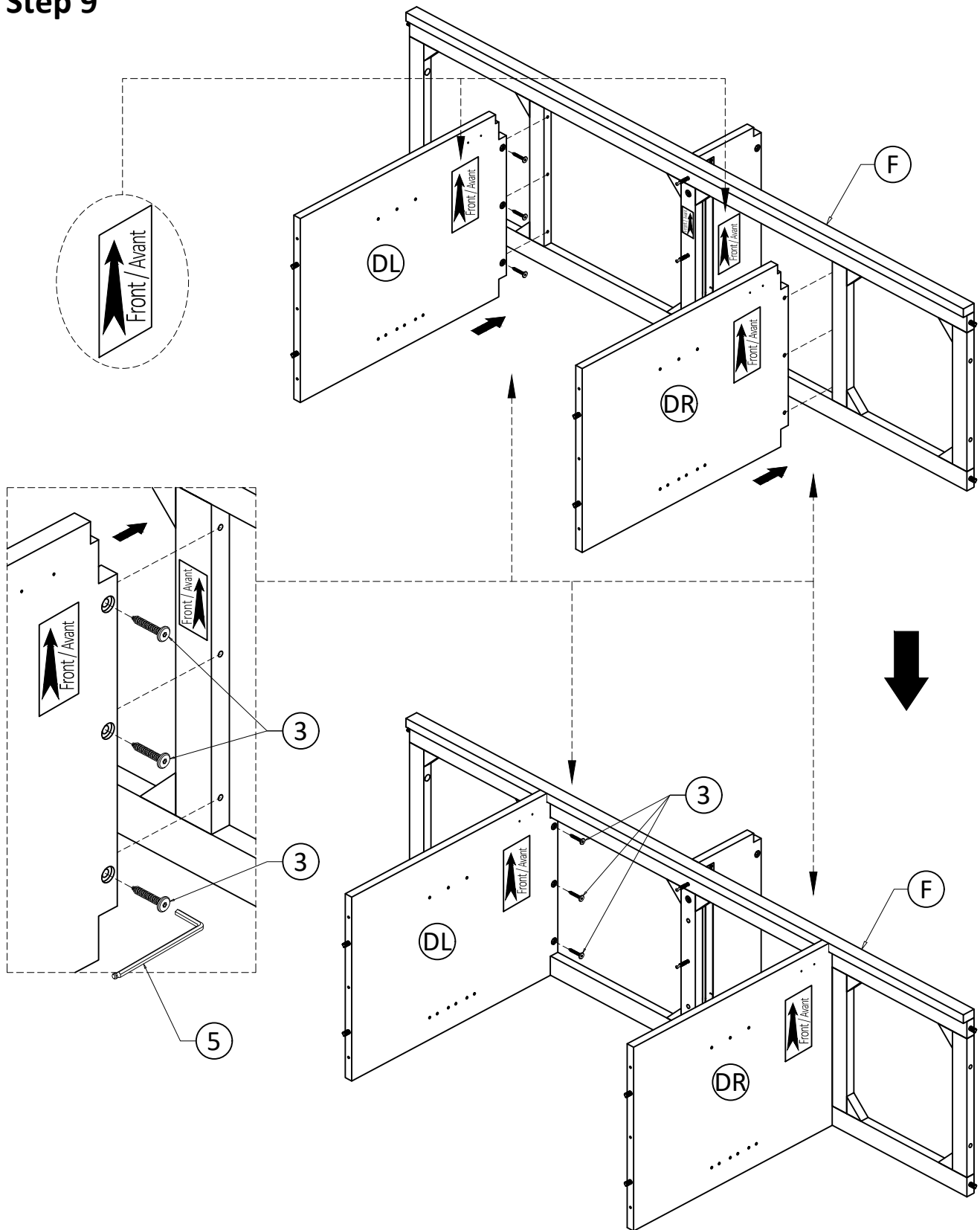

1. Align Dividers (DL), (DR) with pre-drilled holes on Top Frame (F).
2. Use three Allen Key Screws (3) to attach each Divider (DL), (DR) through guide holes.
3. Use Allen Key (5) to tighten Bolts. Do not over-tighten.

Assembly

Step 10

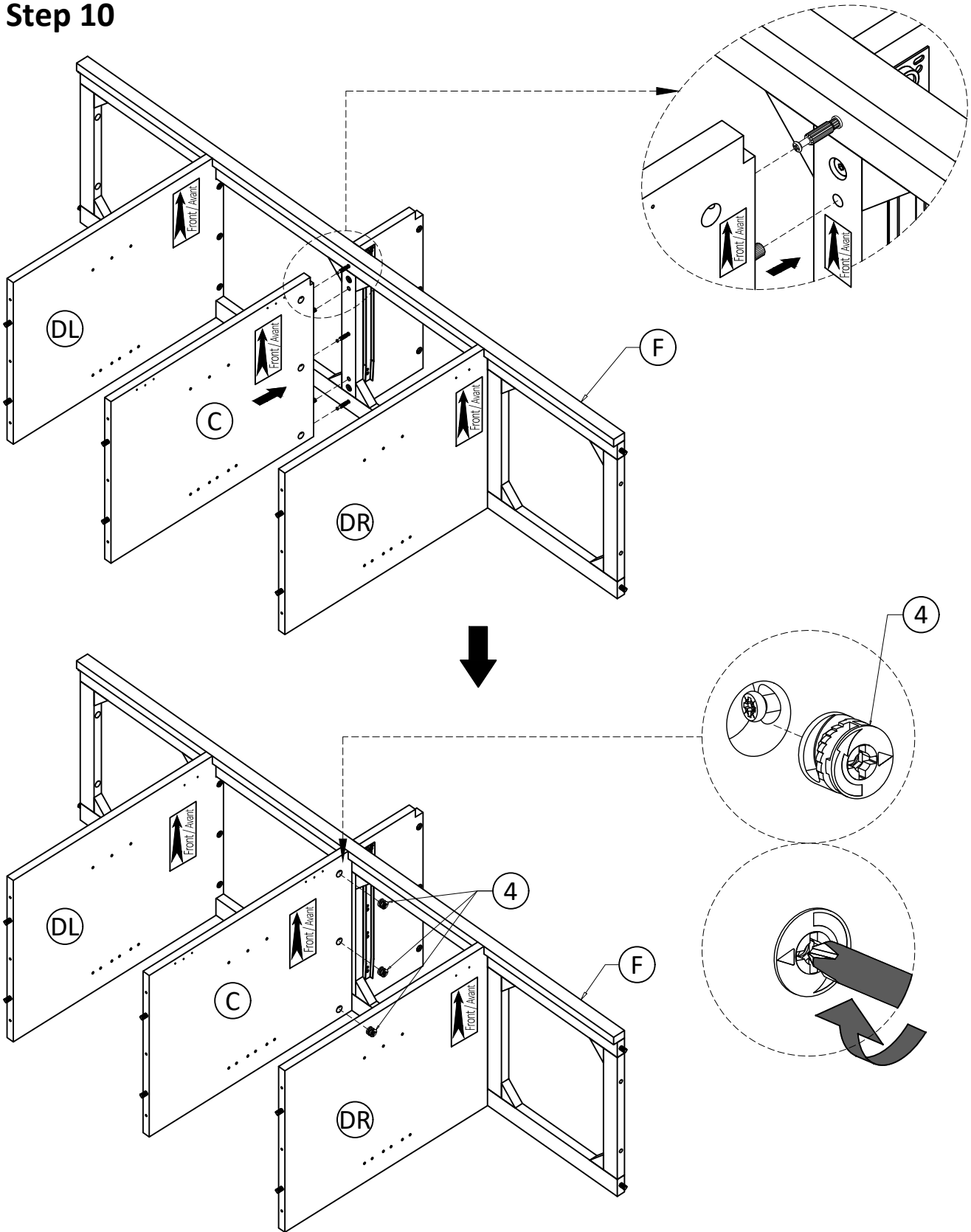

1. Align Cam Lock Pins and Wood Dowels with guide holes and attach Divider (C) to Top Frame (F).
2. Insert three Cam Locks (4) into guided holes on Divider (C).
3. Use Phillips screwdriver to secure Cam Locks. Do not over-tighten.

Assembly

Step 11

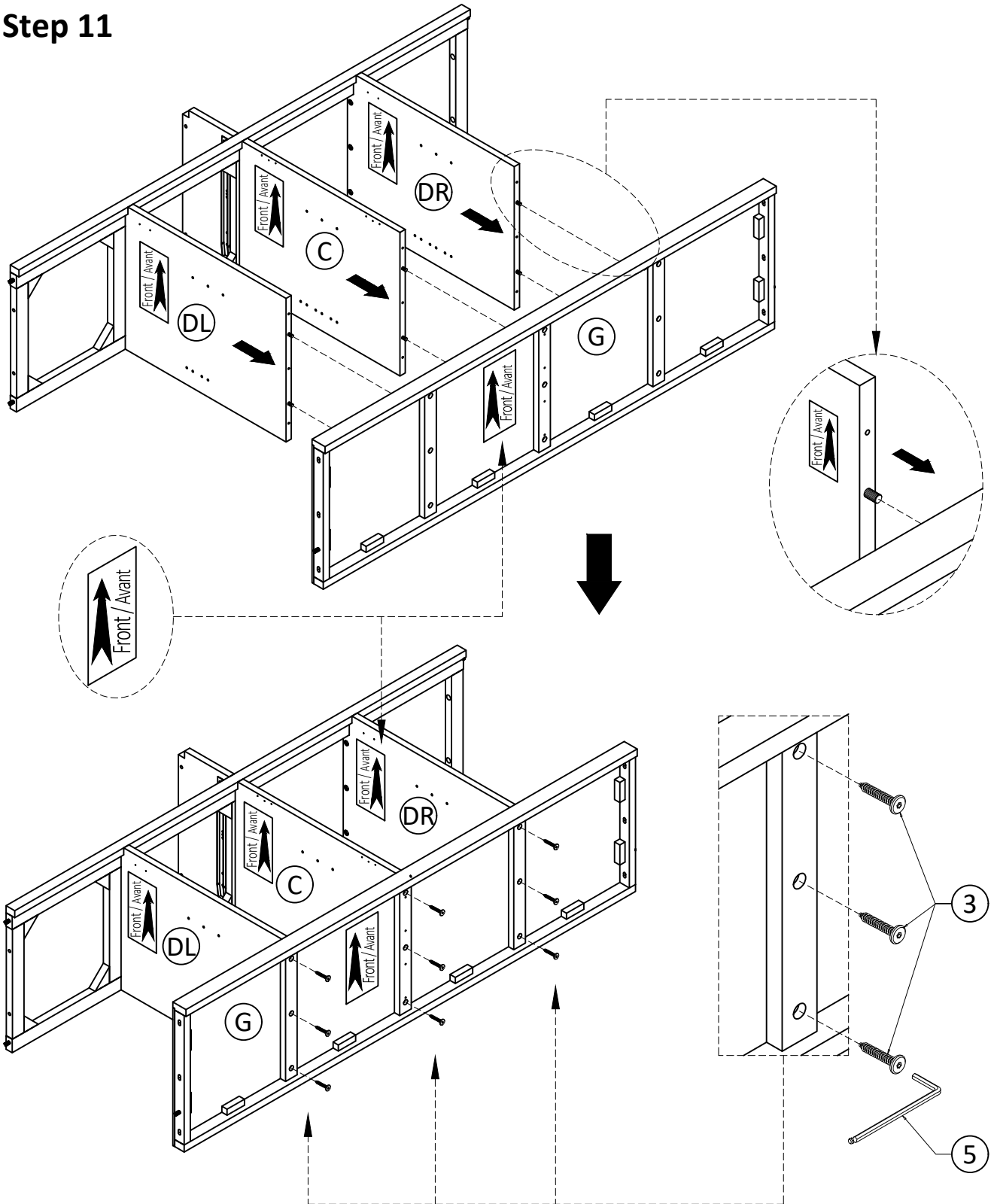

1. Align Wood Dowels with guide holes and attach Dividers (C), (DL), (DR) to Bottom Frame (G).
2. Use nine Allen Key Screws (3) to attach Bottom Frame (G) through guide holes.
3. Use Allen Key (5) to tighten Bolts. Do not over-tighten.

Assembly

Step 12

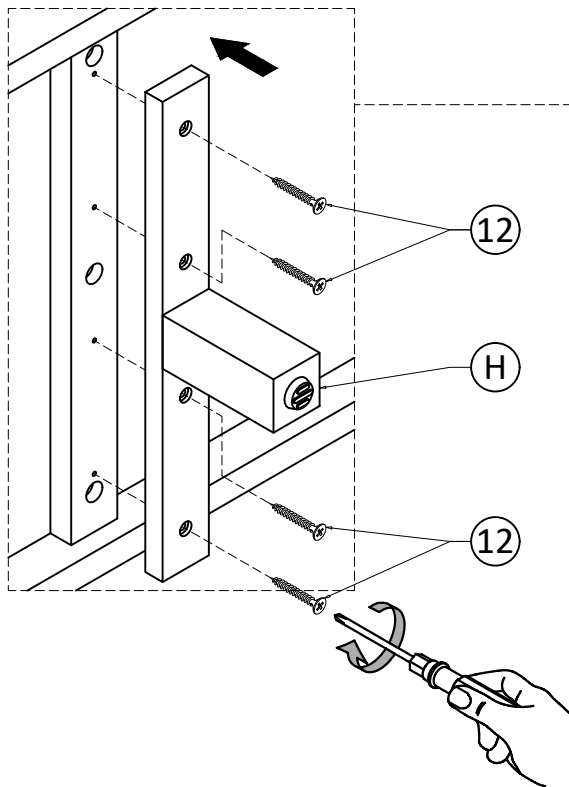
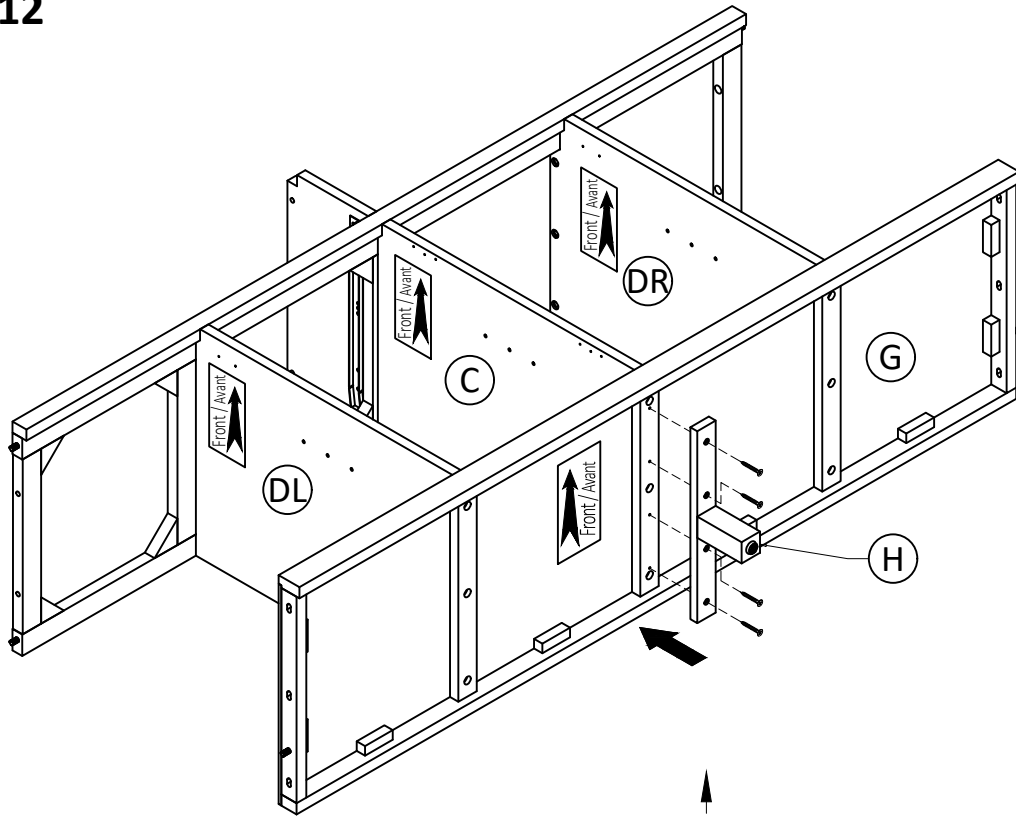

1. Align Bottom Support Leg (H) with pre-drilled holes on back of Bottom Frame (G). Use Phillips Screwdriver to tighten four Phillips Screws (12).

Assembly

Step 13

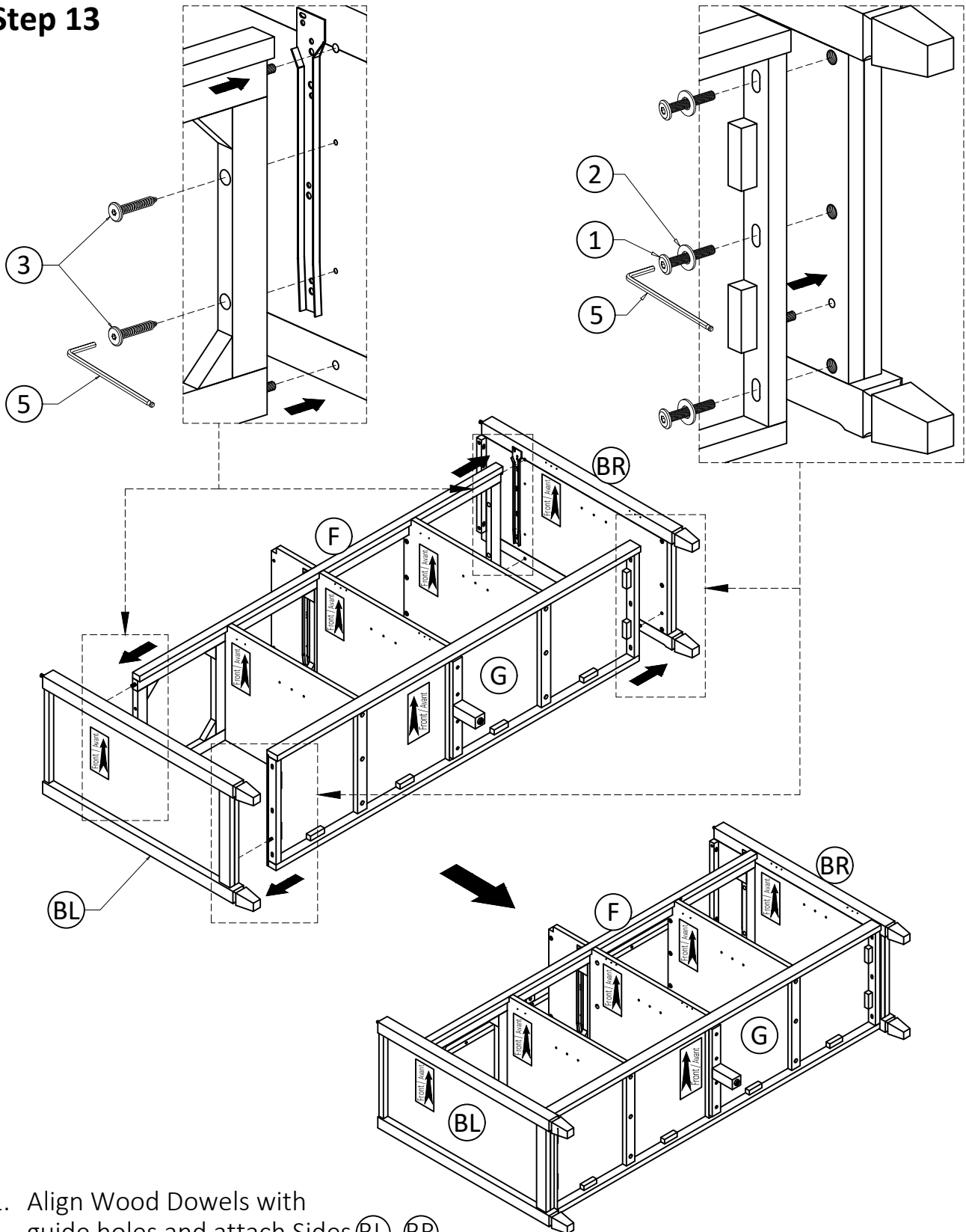

1. Align Wood Dowels with guide holes and attach Sides (BL), (BR) to Top Frame (F) and Bottom Frame (G).
2. Use three Allen Key Bolts (1) and Washer (2) to attach each Side (BL), (BR) through guide holes.
3. Use three Allen Key Screws (3) to attach each Side (BL), (BR) through guide holes.
4. Use Allen Key (5) to tighten Bolts and Screws. Do not over-tighten.

Assembly

Step 14

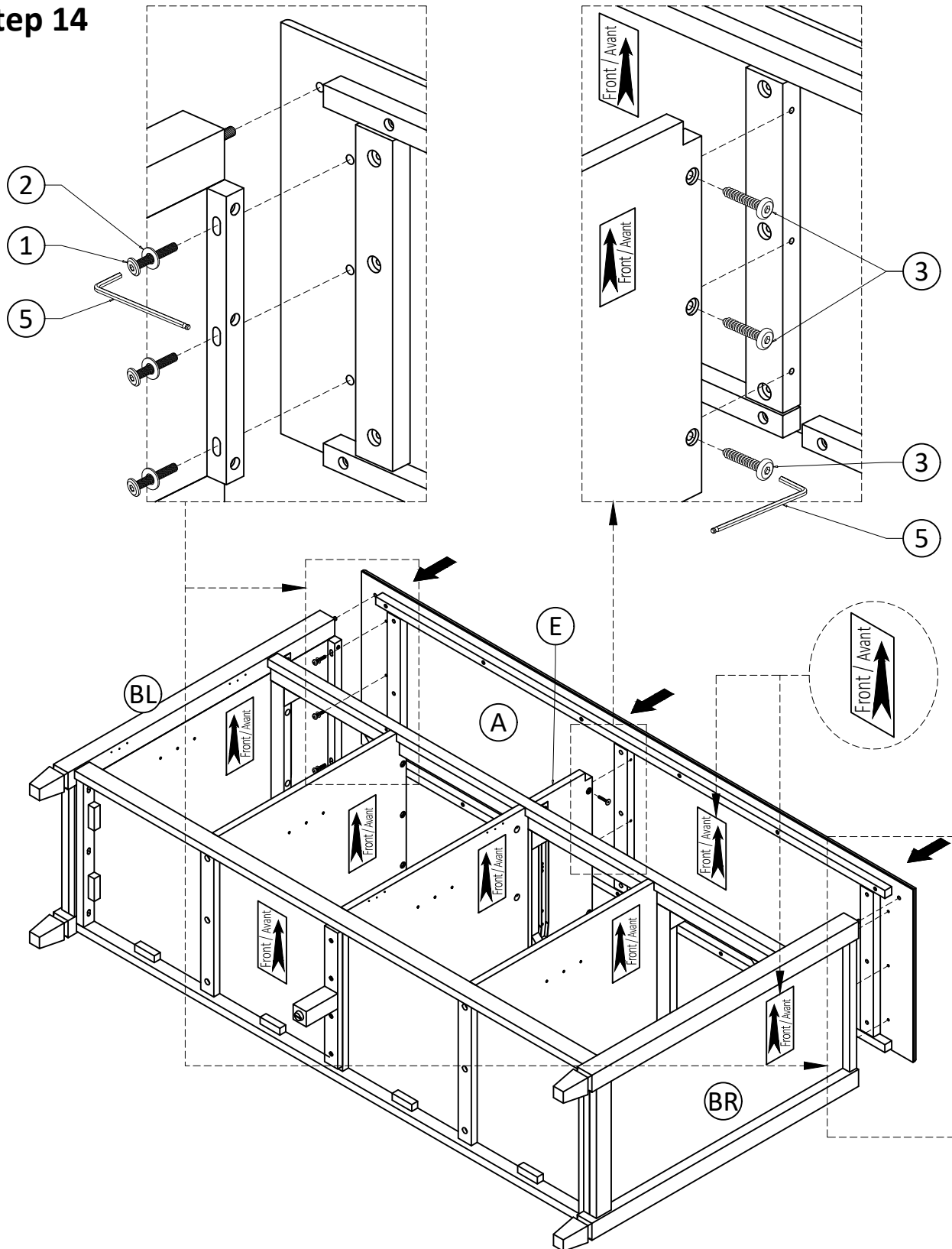

1. Align Wood Dowels with guide holes and attach Sides (BL), (BR) to Top (A).
2. Use three Allen Key Bolts (1) and Washer (2) to attach each Side (BL), (BR) through guide holes.
3. Use three Allen Key Screws (3) to attach each Divider (DL), (DR) through guide holes.
4. Use Allen Key (5) to tighten Bolts. Do not over-tighten.

Assembly

Step 15

Note:

The back of the cabinet frame does not have pre-drilled holes to attach the back panels.

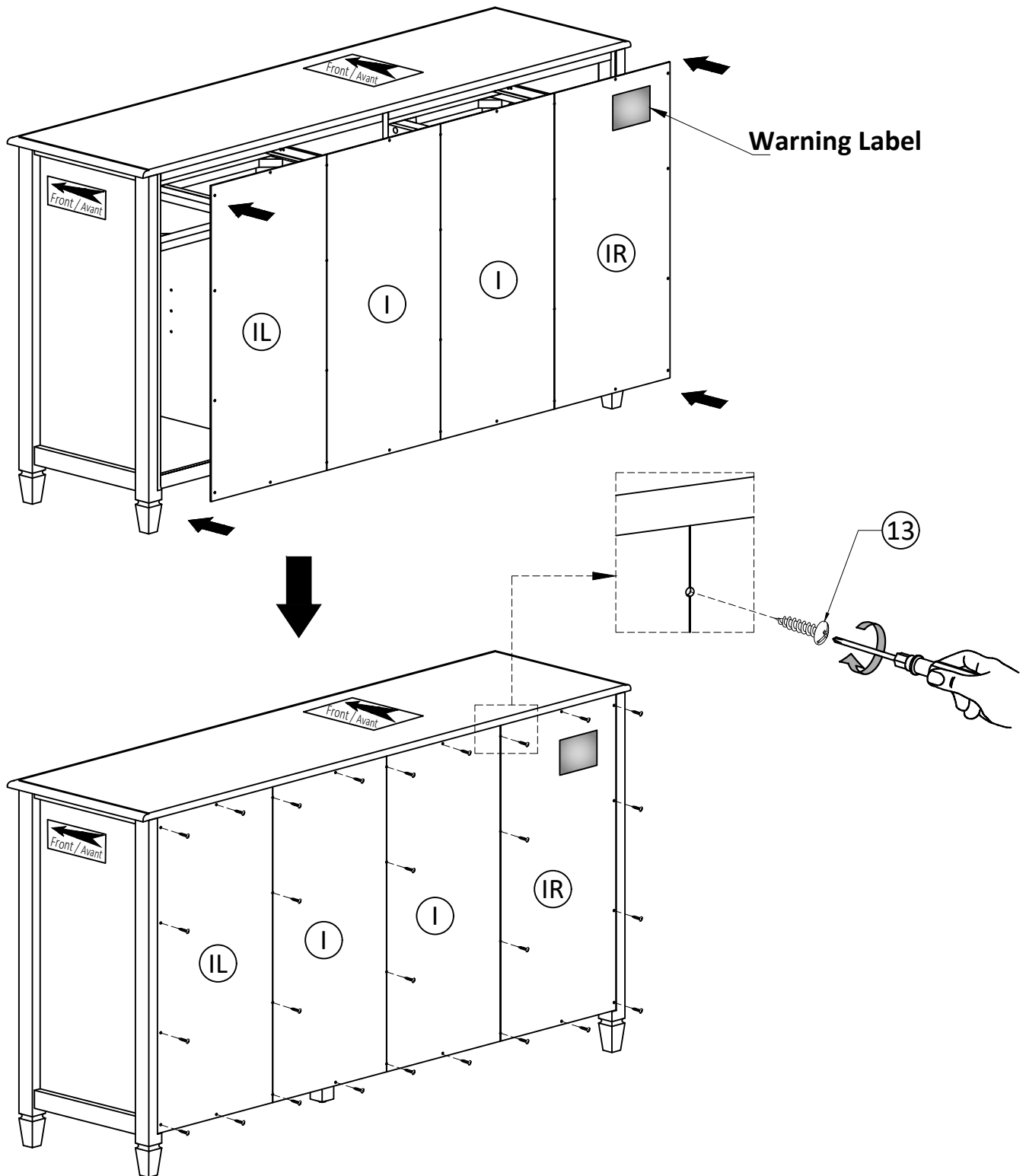

1. Use Phillips Screws Round Head 13 to attach Back Panels IL, IR, I through guide holes from Back Panels to the back of cabinet .
2. Use Phillips screwdriver to tighten screws. Do not over-tighten.

Assembly

Step 16

First Step

Last Step (after adjust the door)

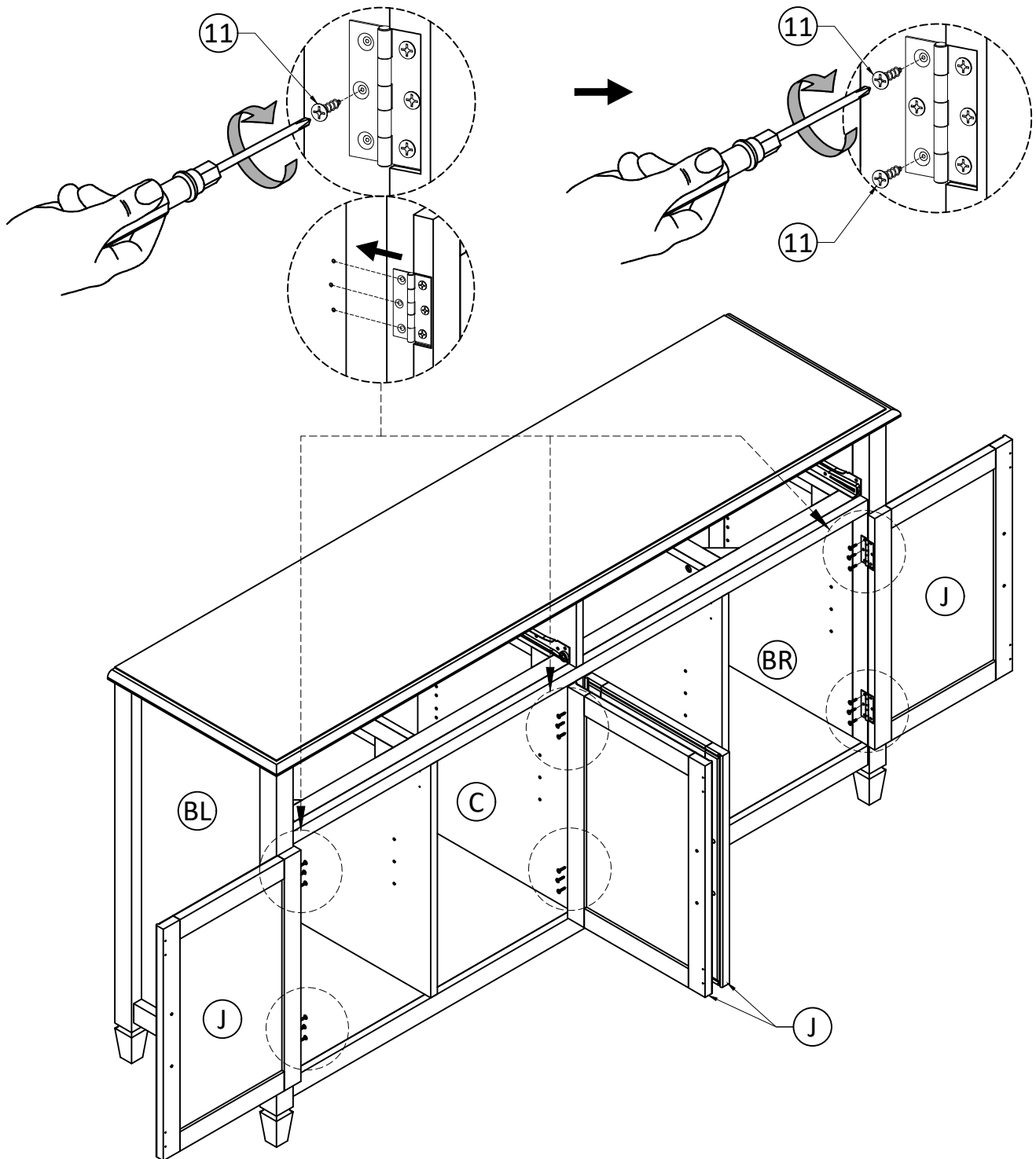

1. Attach hinges on Doors (J) to Sides (BL), (BR) and Divider (C) using Phillips Screws (11) into pre-drill holes:
 - Using Phillips screwdriver to attach Screws (11) at middle hole of hinges for both top & bottom hinges.
 - Adjust the door to ensure they are aligned straight & square with bottom shelf & side.
 - Using Phillips screwdriver to tighten the rest of screws (11) into pre-drill holes (top & bottom holes on hinges).

Assembly

Step 17

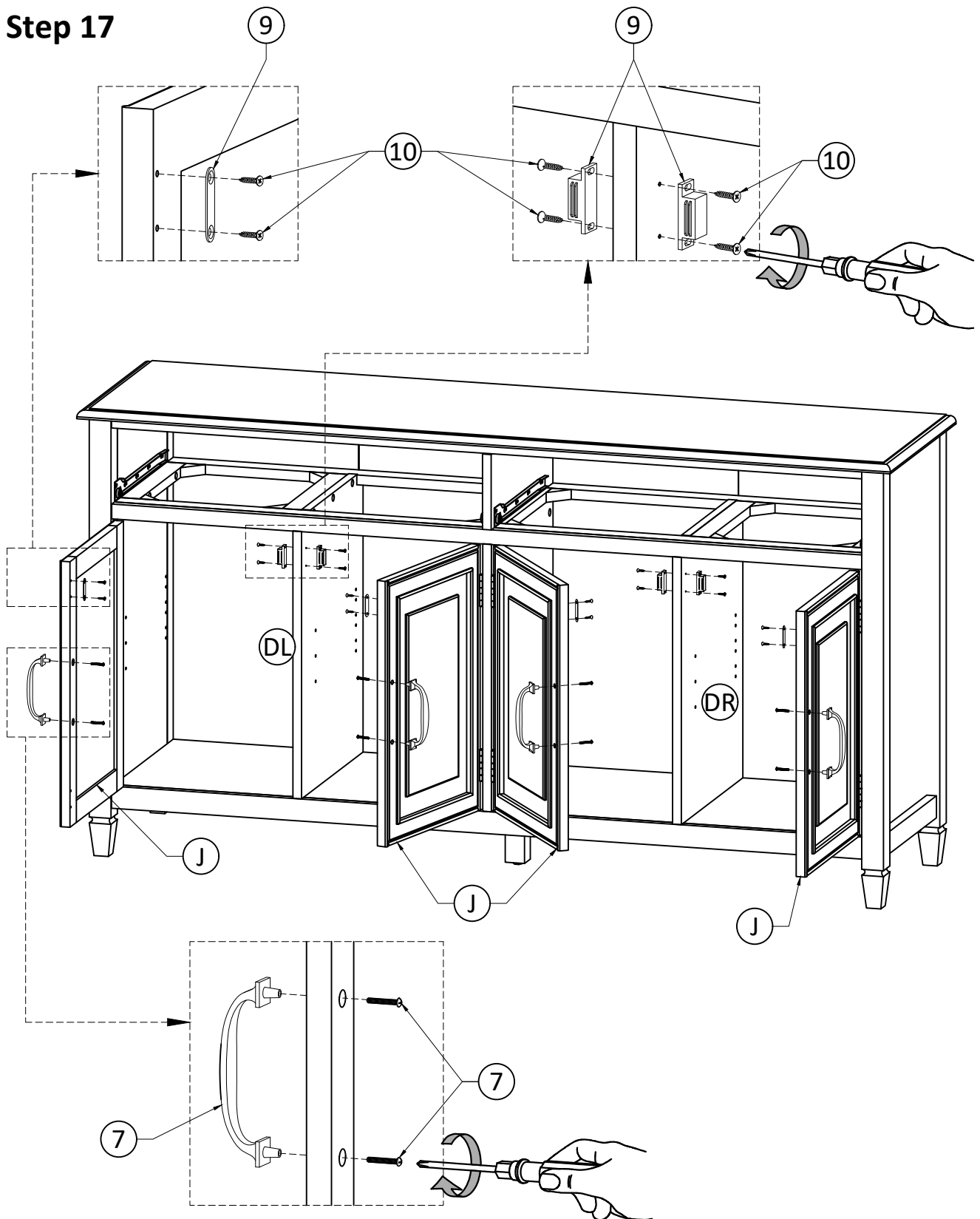

1. Attach Magnets (9) to Dividers (DL, DR) using Phillips Screws (10) into pre-drilled holes on Dividers (DL, DR).
2. Attach Magnet Plates (9) using Phillips Screws (10) into pre-drilled holes on Doors (J).
3. Use Phillips screwdriver to snugly tighten screw.
4. Use Phillips screwdriver to attach Handles (7) to Doors (J) through guide hole.

Assembly

Step 18

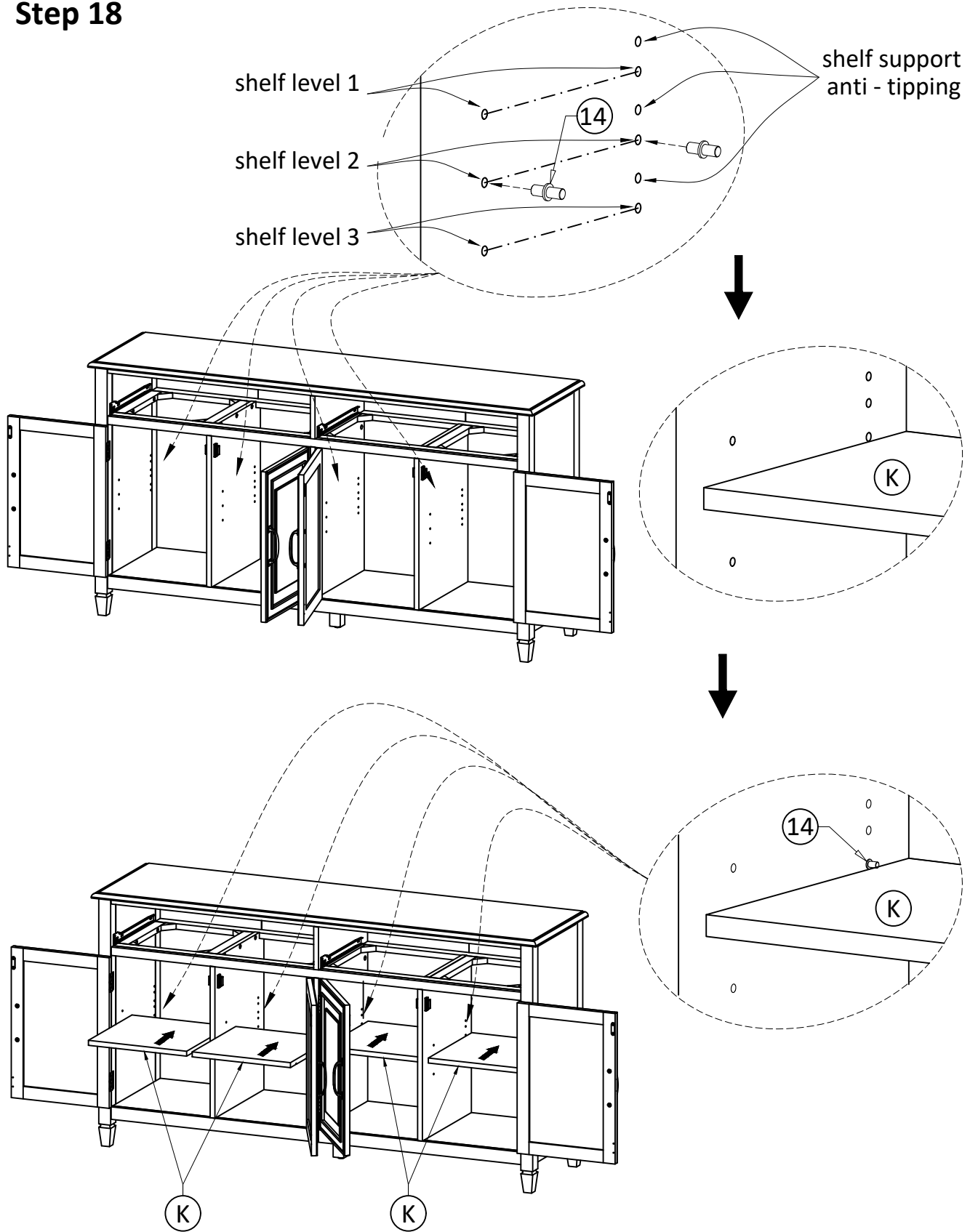

1. Use four Shelf Supports (14) for each Cabinet Shelf (K) in desired location.
2. Two Shelf Supports (14) may be used on back top of each Cabinet Shelf (K) as a tipping restraint.

Assembly

Step 19

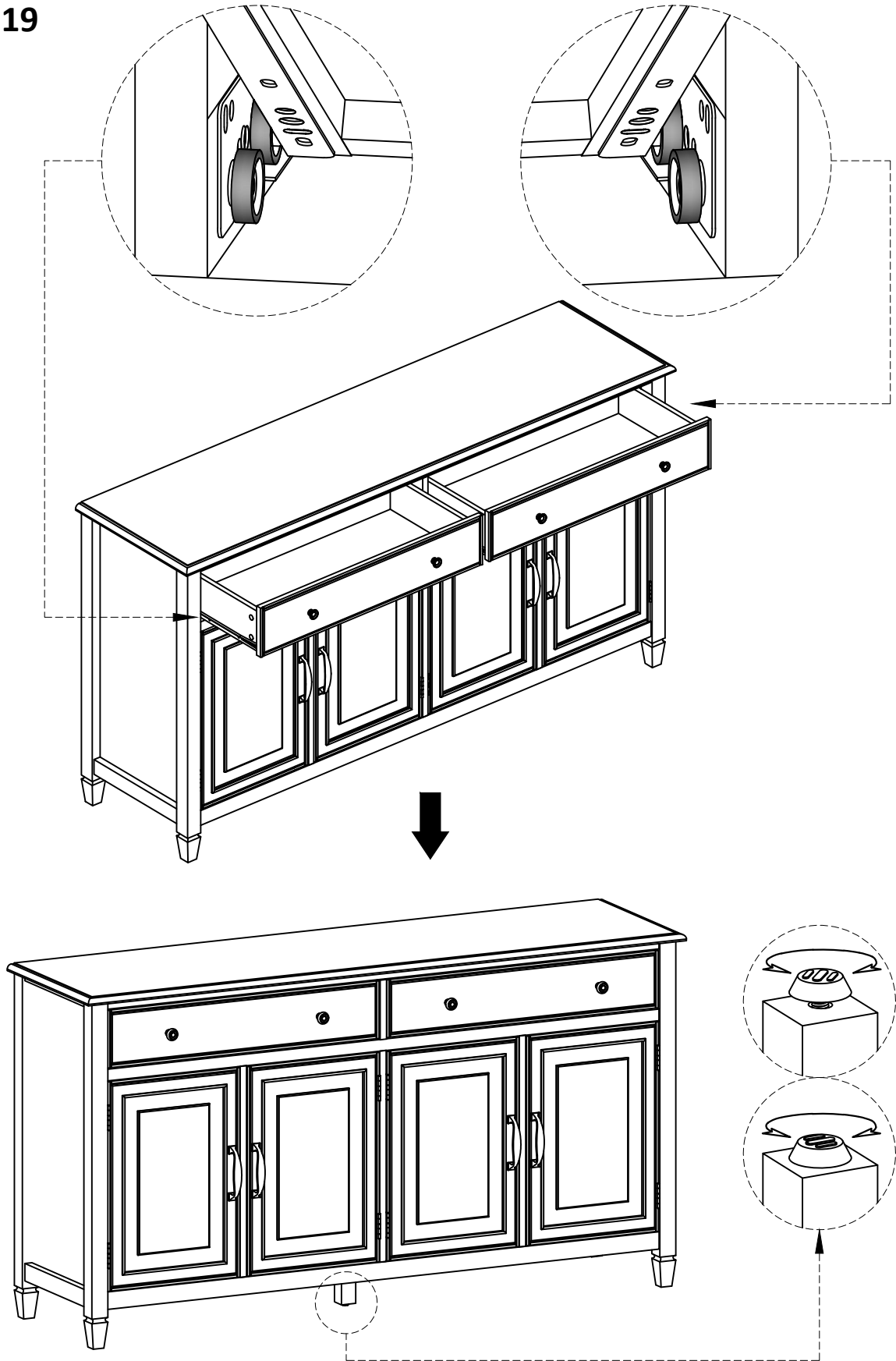

1. Insert assembled drawers into glides on assembled sideboard.
Note: Leveler on bottom of leg can be adjusted if floor is uneven.

Furniture Tip Over Restraint Assembly

WARNING

Serious or fatal crushing injuries can occur from furniture tip-over.
If the furniture tip over restraint kit is not in the box, please contact our customer service department in order to obtain another kit before using the furniture.

Step 20

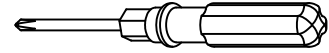

NOTE: The screwdriver is not included in the hardware pack.

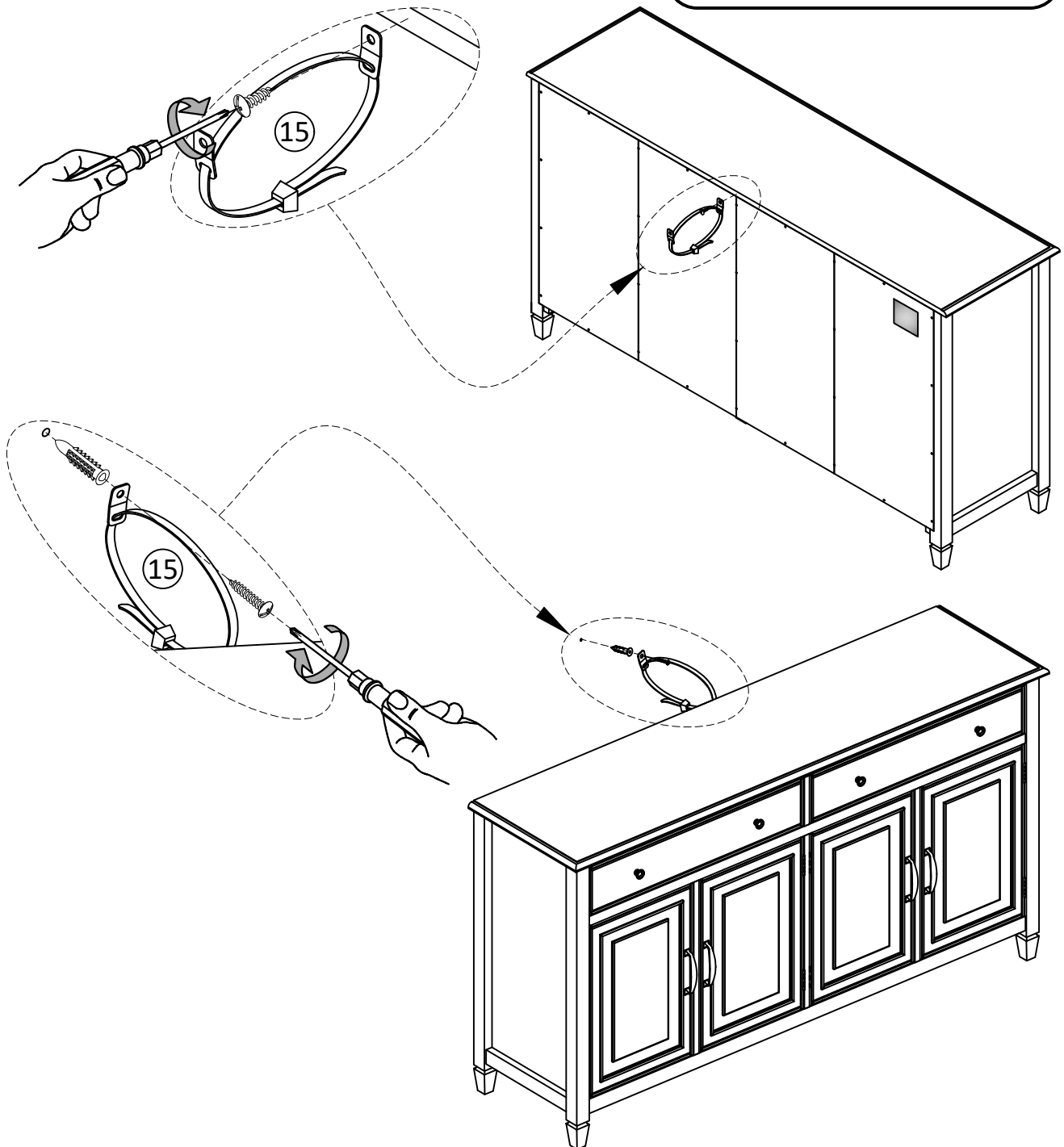

Furniture Anti-Tipping Restraint Instructions

1. Attach one of the mounting brackets securely to the back edge of the furniture. Use the shorter screw.

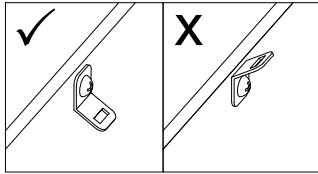

2. Determine where furniture is to be placed and mark location on the wall for mounting bracket screw hole approximately 2 inches below the bracket mounted to the furniture.

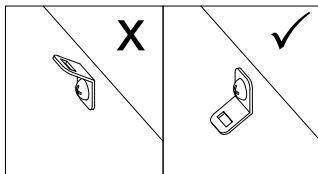

3. Drill a 3/16 inch hole in the wall. Press the plastic anchor into the hole and gently tap until the flange on the anchor is against the wall surface.
4. Position the bracket over the anchor and use the longer screw to securely attach the bracket to the wall.
5. Place the furniture so the back edge is in line with the bracket on the wall.
6. Lace an end of the nylon zip-tie strap down through each bracket. Bring both ends together and slide the smooth side upright through the square-shaped end and pull through to create the "locked" position.
7. Check to make sure the strap is securely laced and locked to the brackets.

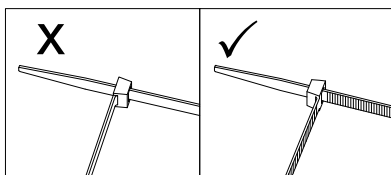

- **DO NOT** put a TV or other heavy objects on top of furniture not intended for use with a TV
- **DO NOT** place heavy objects in top drawers or on top shelves
- **DO NOT** let children climb or hang on drawers, doors or shelves