









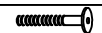

ASSEMBLY INSTRUCTIONS

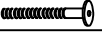
Read this instruction carefully. See hardware and furniture part list for guidance. Be sure all parts are complete, before you assemble. Place all wooden furniture parts on a clean and flat soft surface to prevent from being scratched. Follow the figure to start assembling.

CAUTIONS : 1. Do not FULLY - TIGHTEN the nut or nut bolt until all nut or bolt is ready assembled.
2. Do not OVER - TIGHTEN the nut or bolt to avoid causing damages to the thread.
3. Keep all hardware parts out of reach of children.

NOTE : THE LIST AND QUANTITY SHOWN ARE FOR 1 UNIT ASSEMBLY.
Tool needed : Screwdriver (not provided).

PART LIST		
ITEM	DESCRIPTION	QTY
A	HEADBOARD	1 PC
B	FOOTBOARD	1 PC
C	SIDE RAIL (L)	1 PC
D	SIDE RAIL (R)	1 PC
E	CENTER RAIL	1 PC
F	CENTER SUPPORT	2 PCS
G	CENTER SUPPORT LEG	3 PCS
H	BED SLAT	26 PCS
I	BED LEG	4 PCS

HARDWARE LIST		
ITEM	DESCRIPTION	QTY
1	JCBB BOLT M8 x 30mm 	4 PCS
2	JCBB BOLT M8 x 40mm 	6 PCS
3	JCBB BOLT M8 x 50mm 	4 PCS
4	M8 FLAT WASHER 	6 PCS
5	M8 SPRING WASHER 	6 PCS
6	WOOD SCREW M3.5 x 16mm 	8 PCS
7	PVC BLACK WASHER 	4 PCS
8	BED SLAT SIDE FITTER 	26 PCS
9	BED SLAT CENTER FITTER 	13 PCS
10	M5 ALLEN KEY (BALL SHAPE) 	1 PC

STEP 1

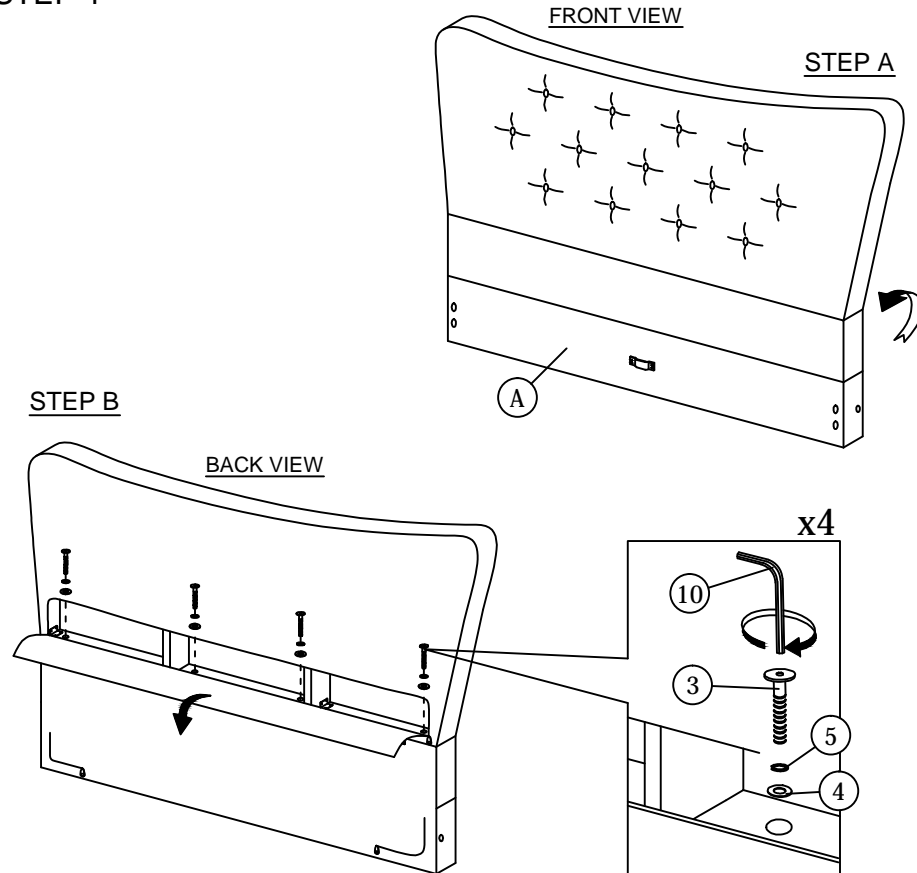

STEP 2

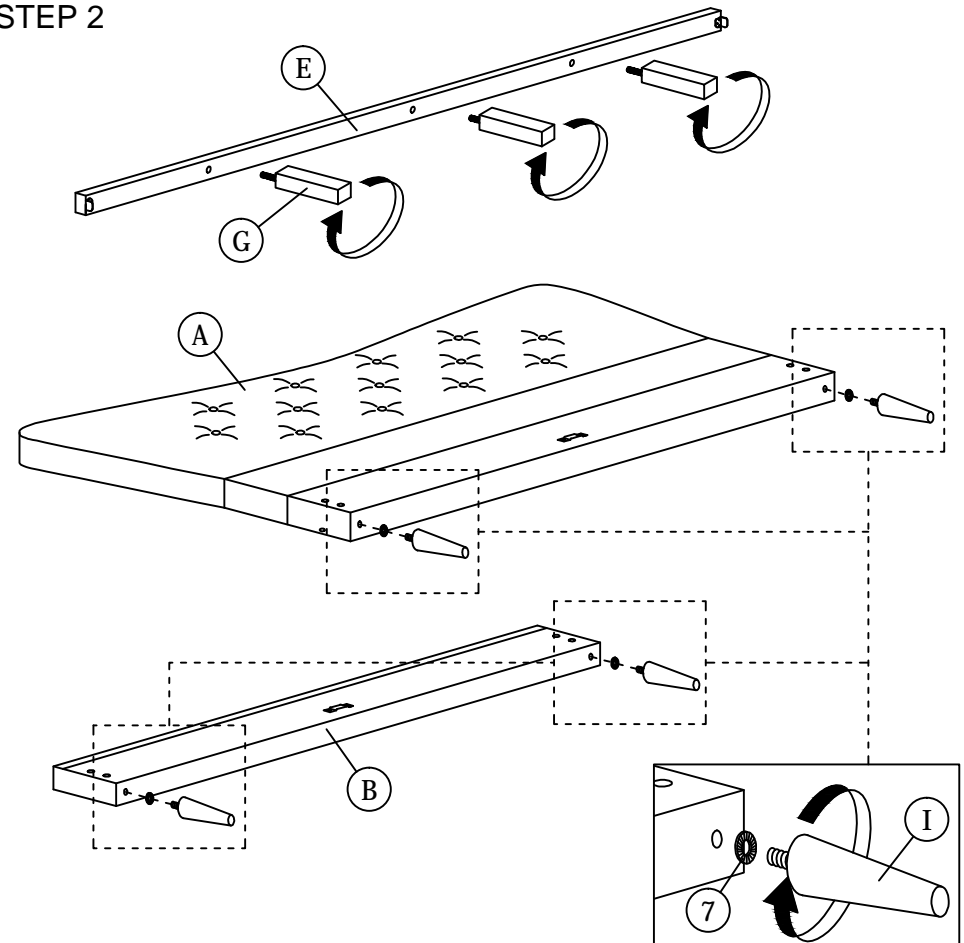

ASSEMBLY INSTRUCTIONS

STEP 3

Loosely fit bolt (2) into Headboard (A) as picture shown.

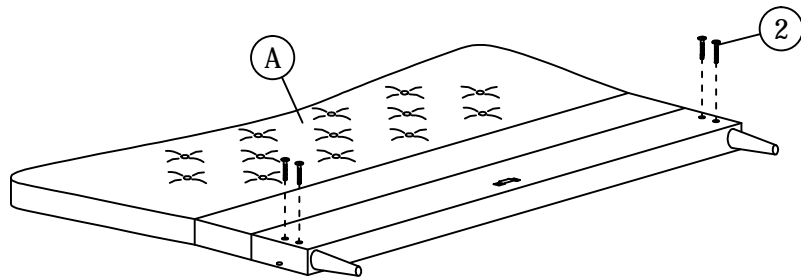

Loosely fit bolt (1) into Footboard (B) as picture shown.

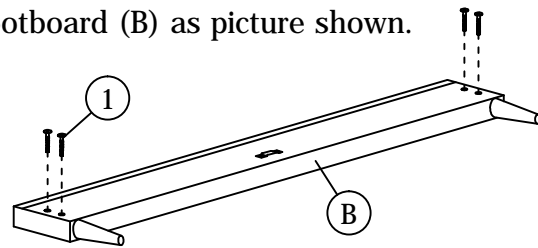

STEP 4.1

STEP A

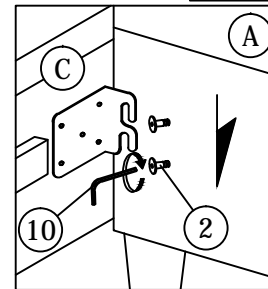

Don't screw tied

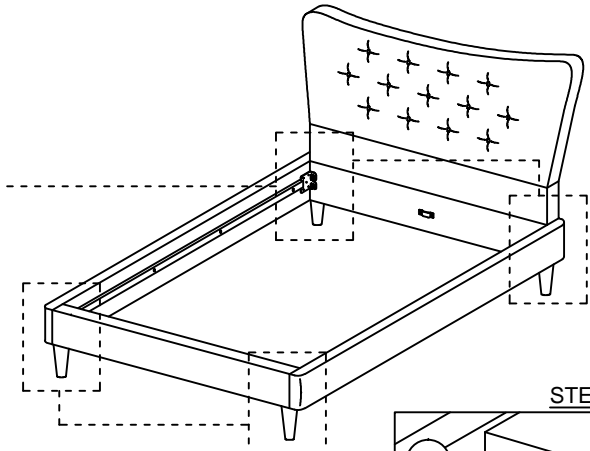

STEP B

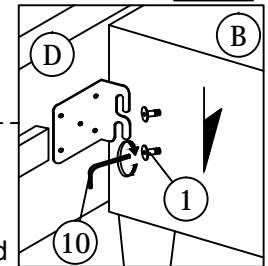

Don't screw tied

STEP 5

STEP A

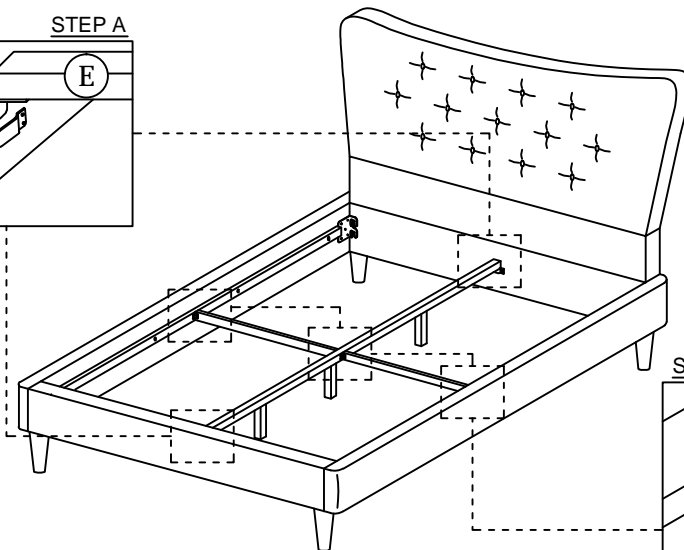
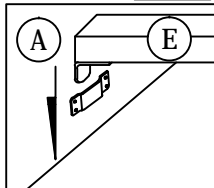

STEP B

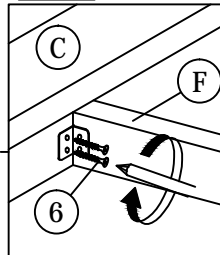

STEP 4.2

STEP C

BACK VIEW

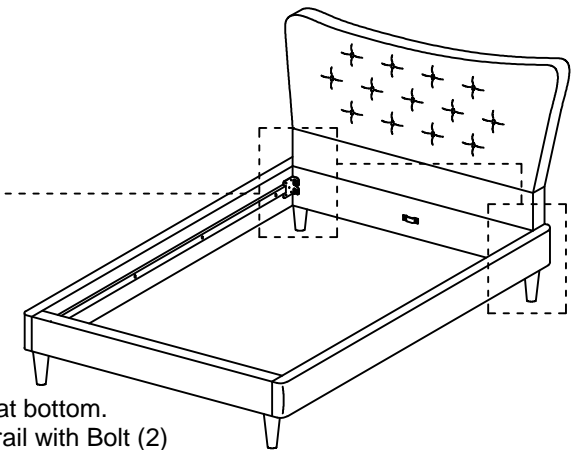
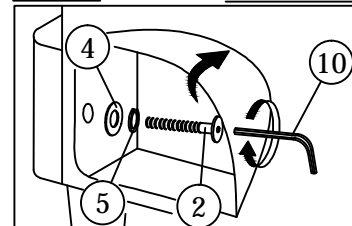

Step C

- Open the headboard backing zip at bottom.
- Tighten the Headboard and Side rail with Bolt (2) and M8 spring washer (5) and M8 flat washer (4) from side as picture shown.

****Finish step C,
Please screw tied the step A & B bolt.**

ASSEMBLY INSTRUCTIONS

STEP 6

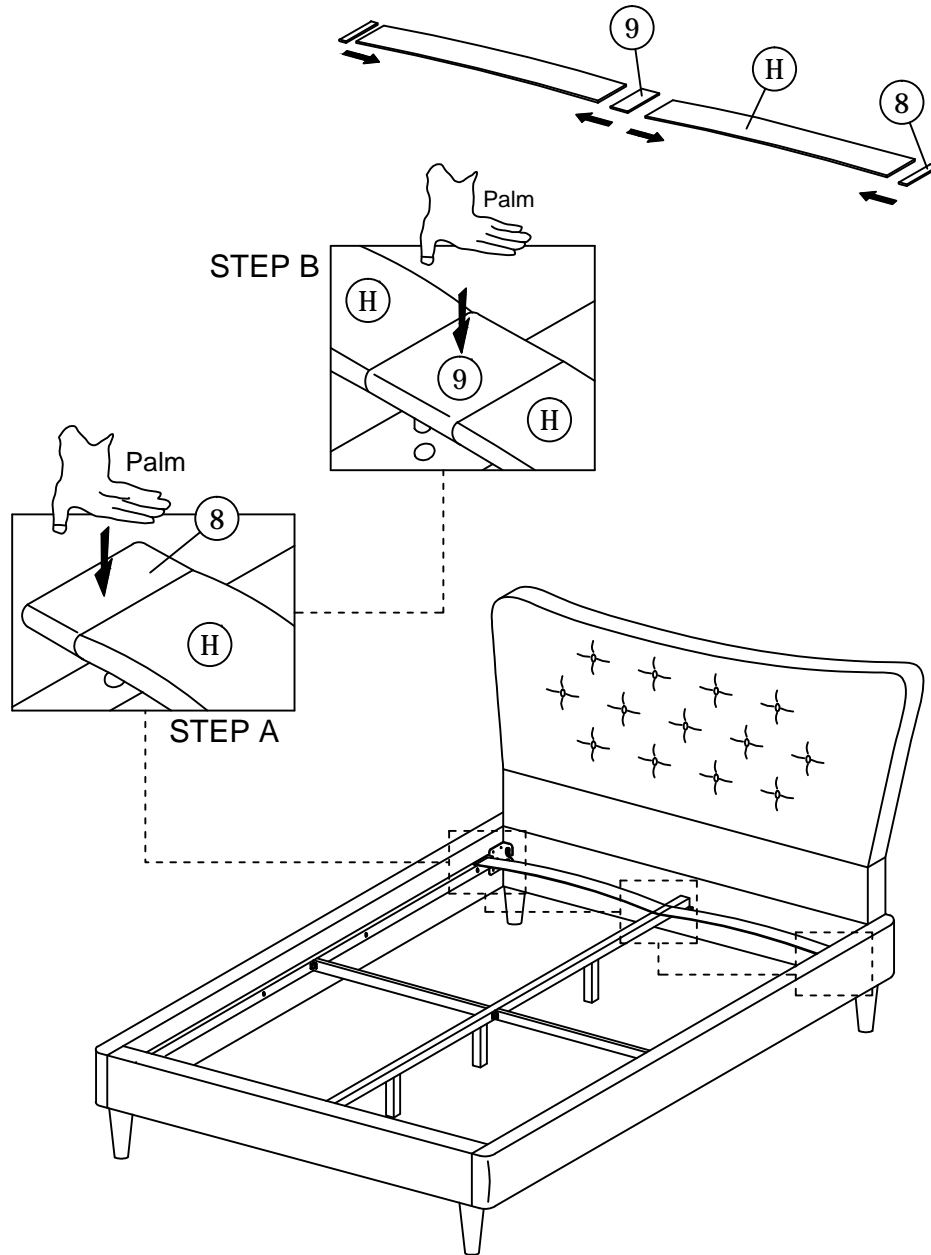

STEP 7

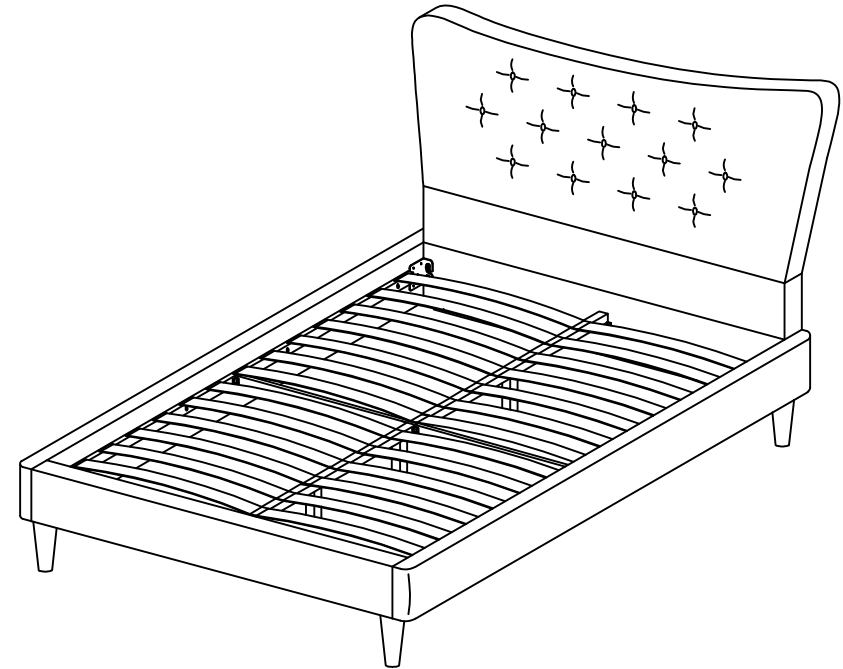

* When moving the bed position, the center support legs must be adjust to be straight to avoid any broken problem.