

# ASSEMBLY INSTRUCTIONS



## MONTAGEANLEITUNGEN

Our product will be delivered to you in 2 packages. The delivery times of these 2 packages may differ, please be patient and thank you for your understanding.

Unser Produkt wird Ihnen in 2 Paketen geliefert. Die Lieferzeiten dieser 2 Pakete können abweichen, bitte haben Sie etwas Geduld und vielen Dank für Ihr Verständnis.

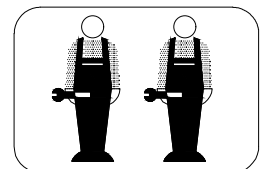
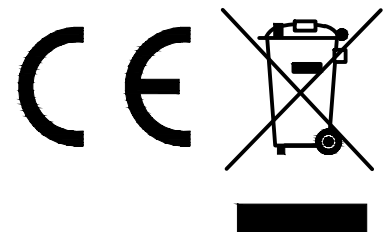
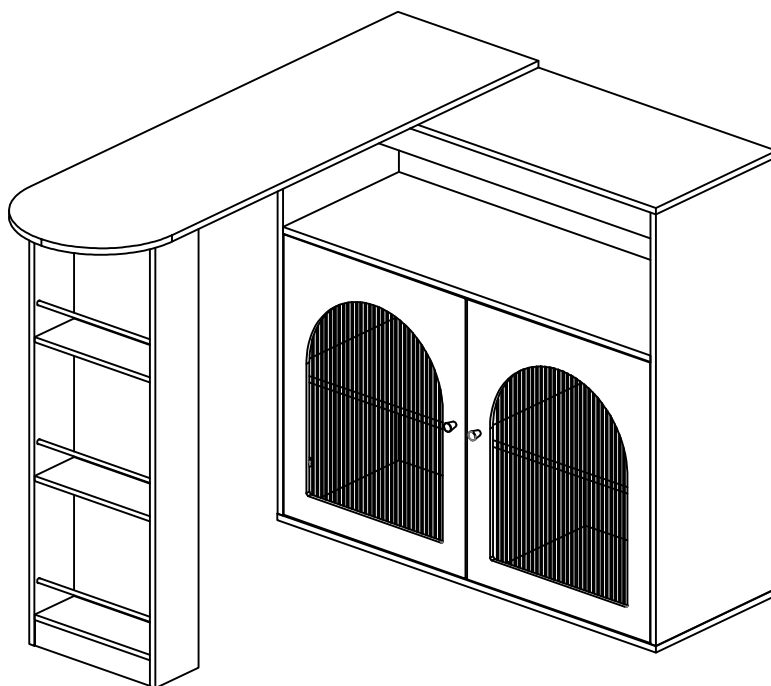
Nos produits vous seront livrés en deux colis. Les délais de livraison peuvent être différents pour les deux colis, veuillez patienter et vous remercier de votre compréhension.



 Ø15×12mm	 Ø15×10mm
Ⓑ×21pcs	Ⓒ×26pcs

Bitte beachten Sie, dass die Formen der Schrauben B und C ähnlich sind. Bitte installieren Sie entsprechend der Anleitung und unterscheiden Sie sie!

Please note that the shapes of screws B and C are similar. Please install according to the instructions and distinguish them!

Notez que les vis B et C ont des formes similaires. Veuillez les installer en suivant les instructions pour les séparer!







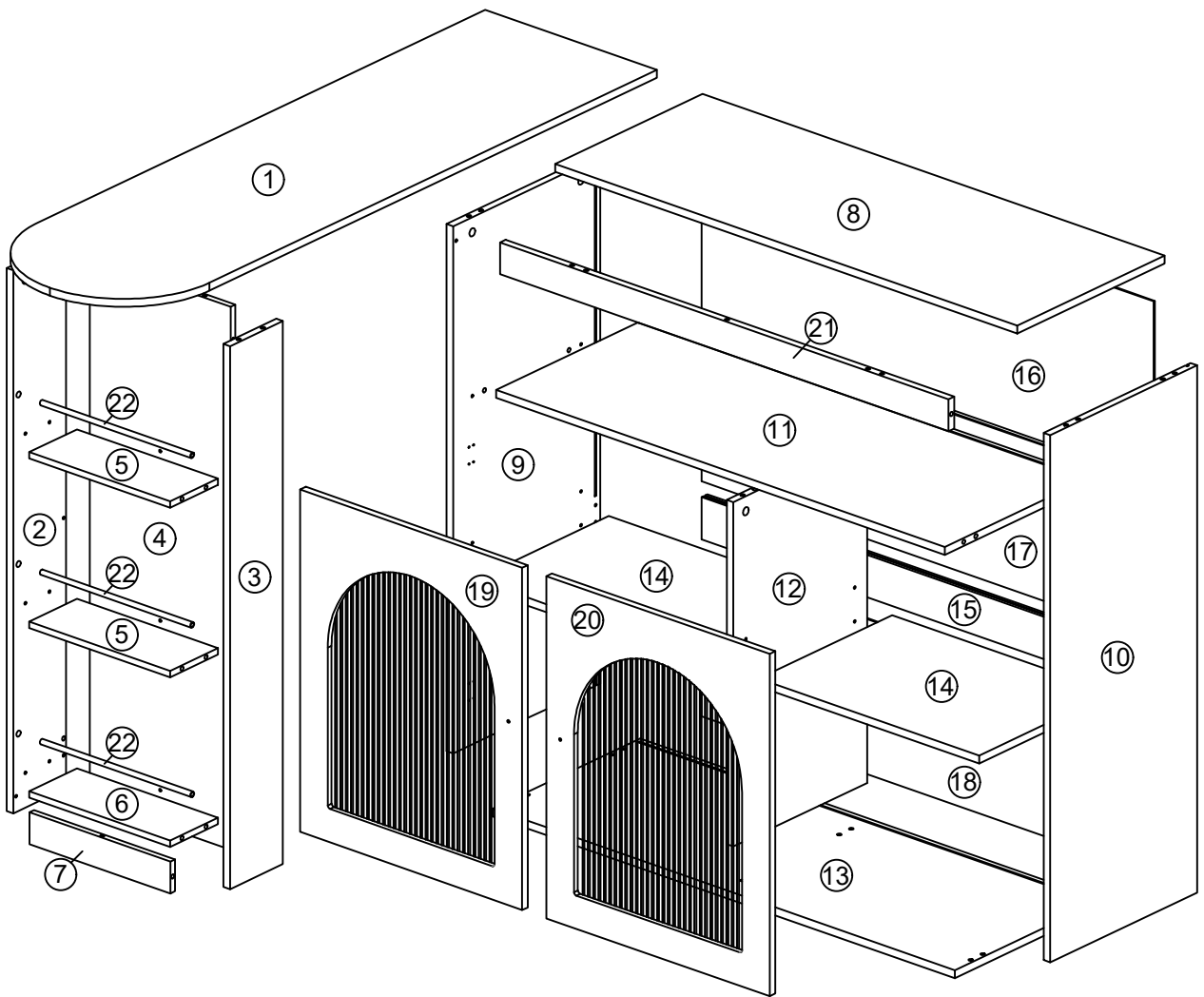

Vor dem Einbau die Schrauben in die Löcher stecken und festziehen, aber nicht bis 100%, 70% bis 80% anziehen reicht aus. Schließlich, nachdem alle Schrauben installiert sind, ziehen Sie alle Schrauben auf 100%. Wenn Sie auf diese Probleme stoßen, z.B. wenn die Löcher nicht ausgerichtet werden können oder einige Teile nicht installiert werden können, überprüfen Sie bitte, ob die Schrauben korrekt verwendet werden und passen Sie die Dichtheit der Schrauben an.

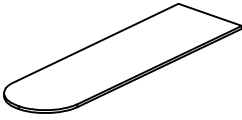
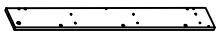
Before installation, insert the screws into the holes and tighten them, but do not tighten them to 100%, 70% to 80% is sufficient. Finally, after all screws are installed, tighten all screws to 100%. If you encounter these issues, such as if the holes cannot be aligned or some parts cannot be installed, please check if the screws are used correctly and adjust the tightness of the screws.

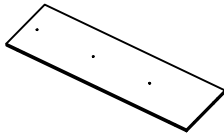
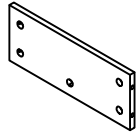
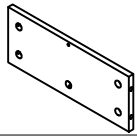
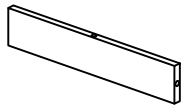

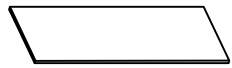

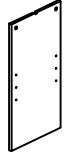
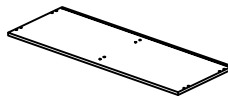
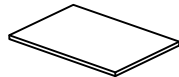
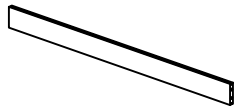
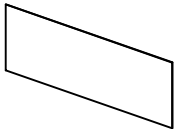
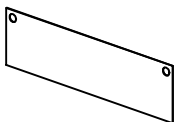
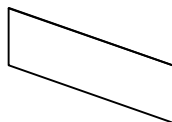

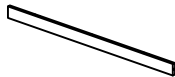
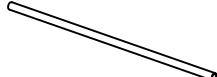



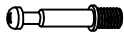

Insérer la vis dans le trou avant la fin de l'assemblage, serrer la vis, mais ne pas serrer à 100%, 70% ~ 80% est correct. Enfin, une fois que toutes les vis sont bien serrées, toutes les vis sont serrées à 100%. Si vous rencontrez ces problèmes, par exemple si les trous ne sont pas alignés ou si certaines pièces ne peuvent pas être montées, vérifiez que les vis sont utilisées correctement et Ajustez leur serrage.

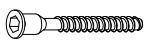

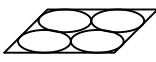
## Part List Stückliste

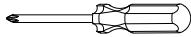
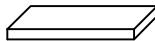
				
① ×1pc	② ×1pc	③ ×1pc	④ ×1pc	⑤ ×2pcs
				
⑥ ×1pc	⑦ ×1pc	⑧ ×1pc	⑨ ×1pc	⑩ ×1pc
				
⑪ ×1pc	⑫ ×1pc	⑬ ×1pc	⑭ ×2pcs	⑮ ×1pc
				
⑯ ×1pc	⑰ ×1pc	⑱ ×1pc	⑲ ×1pc	⑳ ×1pc
				
㉑ ×1pc	㉒ ×3pcs			

## Hardware List Hardwareliste

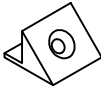
				
Ø6×35mm	Ø15×12mm	Ø15×10mm	Ø8×30mm	
Ⓐ ×47pcs	Ⓑ ×21pcs	Ⓒ ×26pcs	Ⓓ ×26pcs	Ⓔ ×2pcs
				
Ø7×40mm	4×20mm			
Ⓕ ×6pcs	Ⓖ ×2pcs	Ⓗ ×20pcs	Ⓘ ×4pcs	Ⓝ ×1pc
				
	50×13×5mm			3.5×14mm
Ⓚ ×1pc	Ⓛ ×8pcs	Ⓜ ×1pc	Ⓝ ×2pcs	Ⓞ ×30pcs
				
Ø5×14mm	14×14×9mm			
Ⓟ ×8pcs	Ⓠ ×6pcs			

# Step 1 Schritt 1

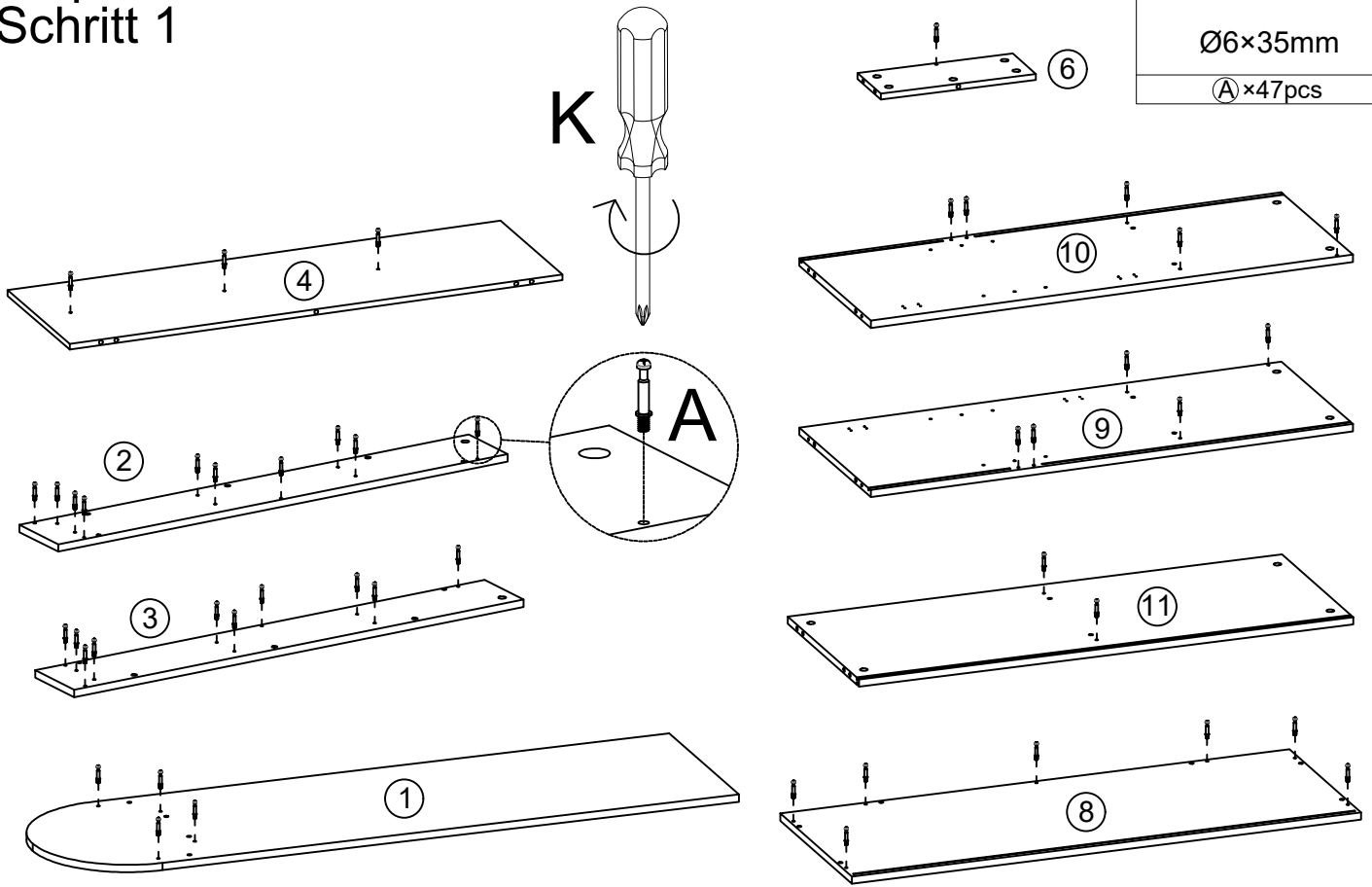

# Step 2 Schritt 2

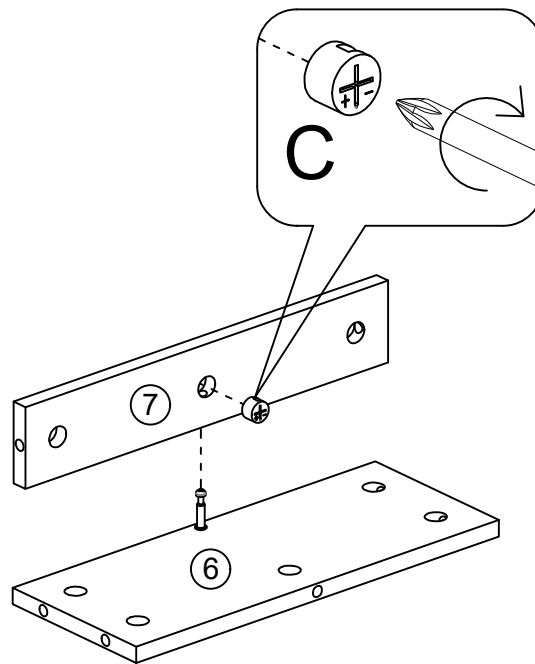

  
 $\text{Ø}15 \times 10\text{mm}$   
 $\text{C} \times 1\text{pc}$

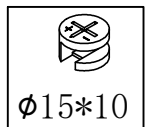
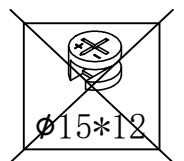

### Step 3 Schritt 3

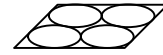

H×2pcs



Ø15×10mm

C×3pcs

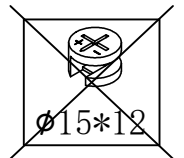
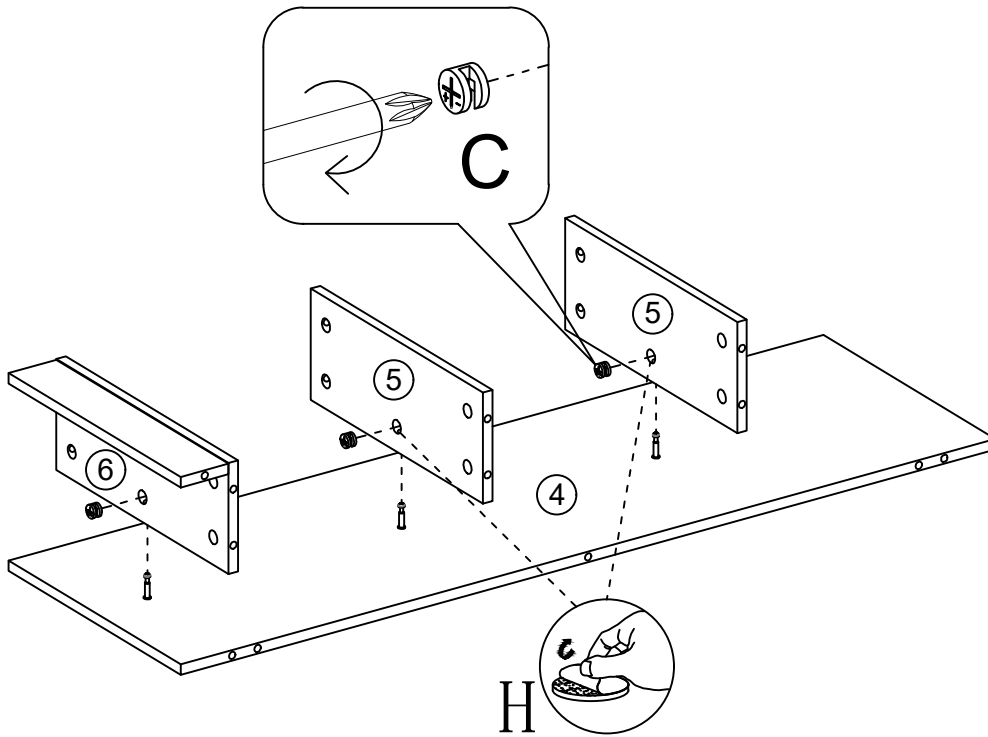

Ø15×12



Ø15×10

### Step 4 Schritt 4

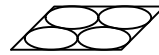

H×4pcs



Ø8×30mm

D×2pcs



Ø15×10mm

C×7pcs

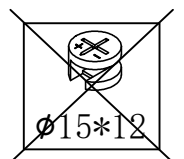
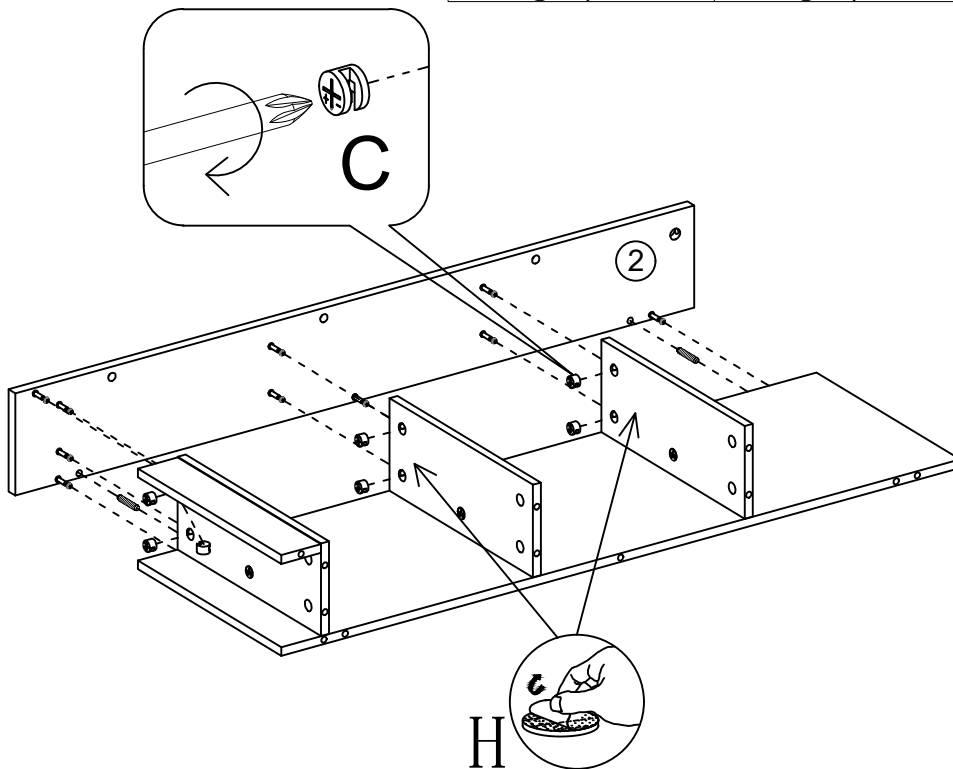



Ø15×12



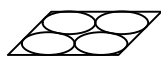

Ø15×10

# Step 5 Schritt 5

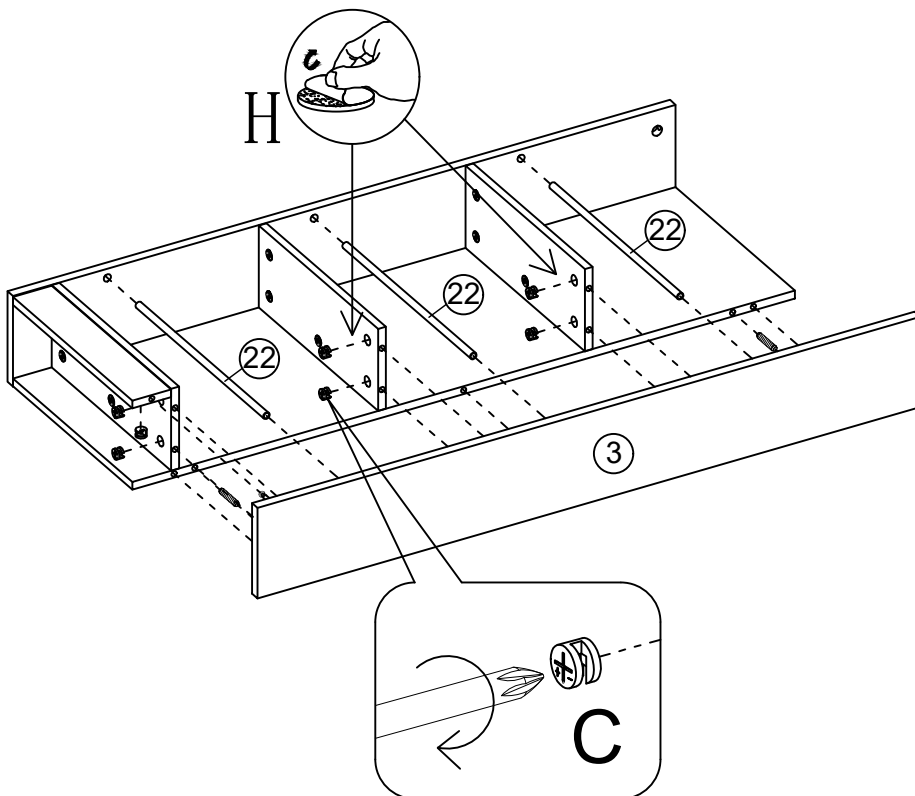
		
Ø8×30mm	Ø15×10mm	
(H)×4pcs	(D)×2pcs	(C)×7pcs



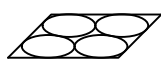

# Step 6 Schritt 6

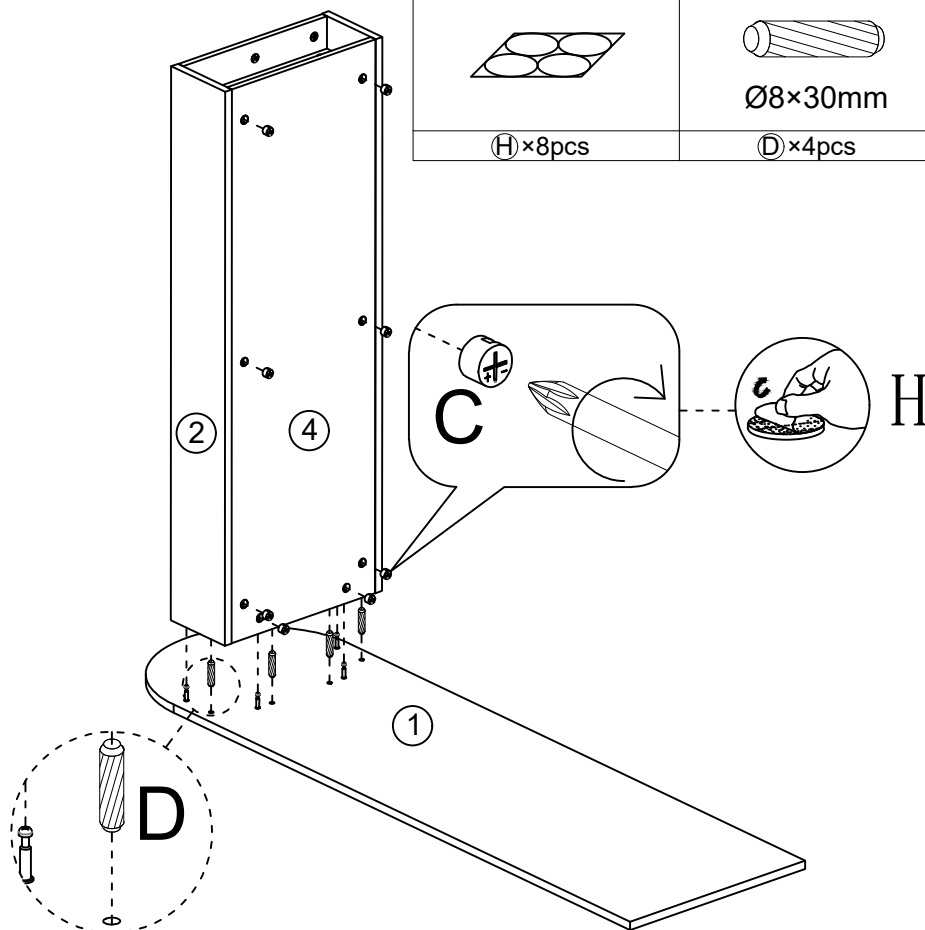
		
Ø8×30mm	Ø15×10mm	
(H)×8pcs	(D)×4pcs	(C)×8pcs



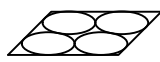
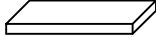

# Step 7 Schritt 7

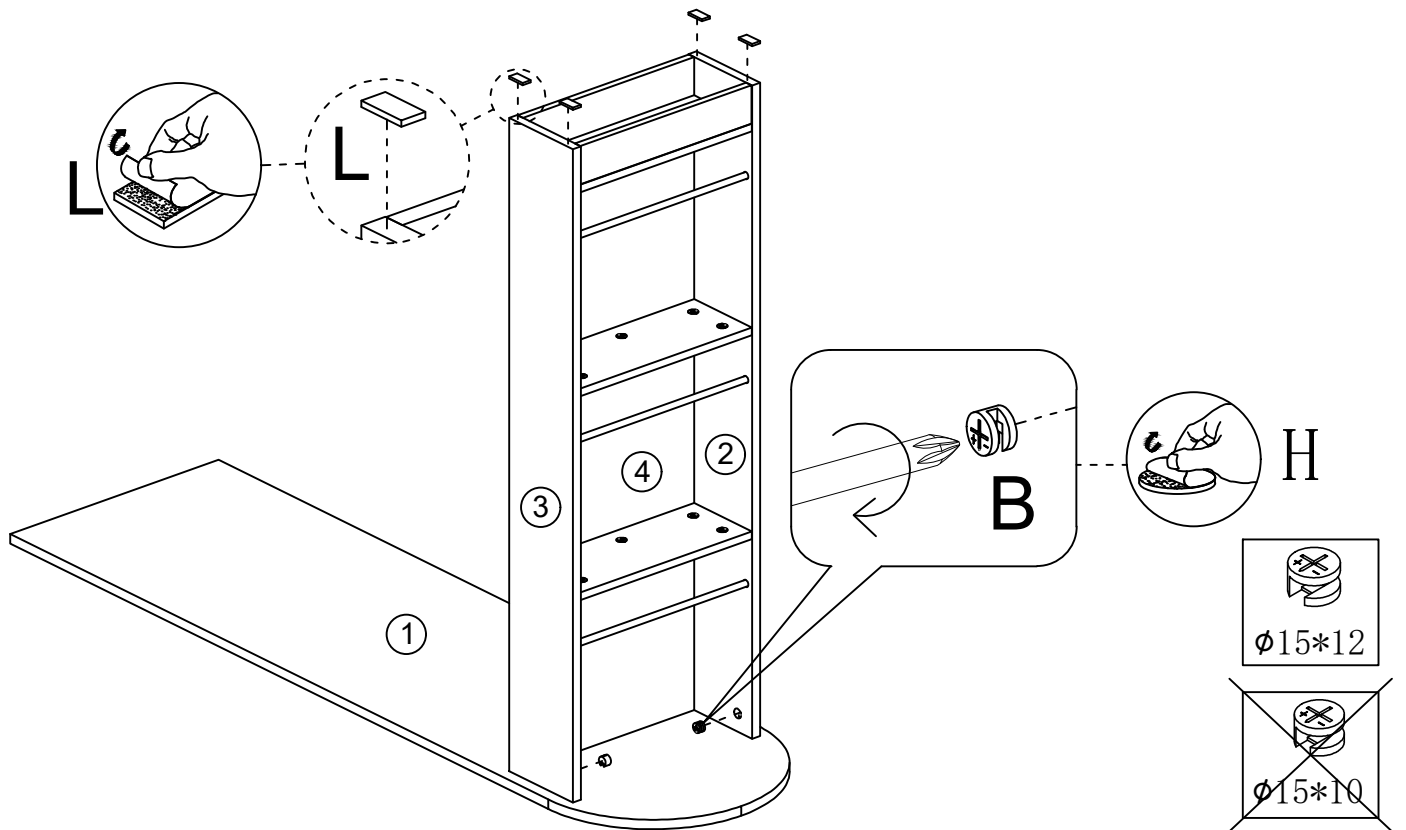
		
$(H) \times 2\text{pcs}$	$50 \times 13 \times 5\text{mm}$	$\text{Ø}15 \times 12\text{mm}$
	$(L) \times 4\text{pcs}$	$(B) \times 2\text{pcs}$



# Step 8 Schritt 8

	
$\text{Ø}8 \times 30\text{mm}$	$\text{Ø}15 \times 12\text{mm}$
$(D) \times 2\text{pcs}$	$(B) \times 5\text{pcs}$

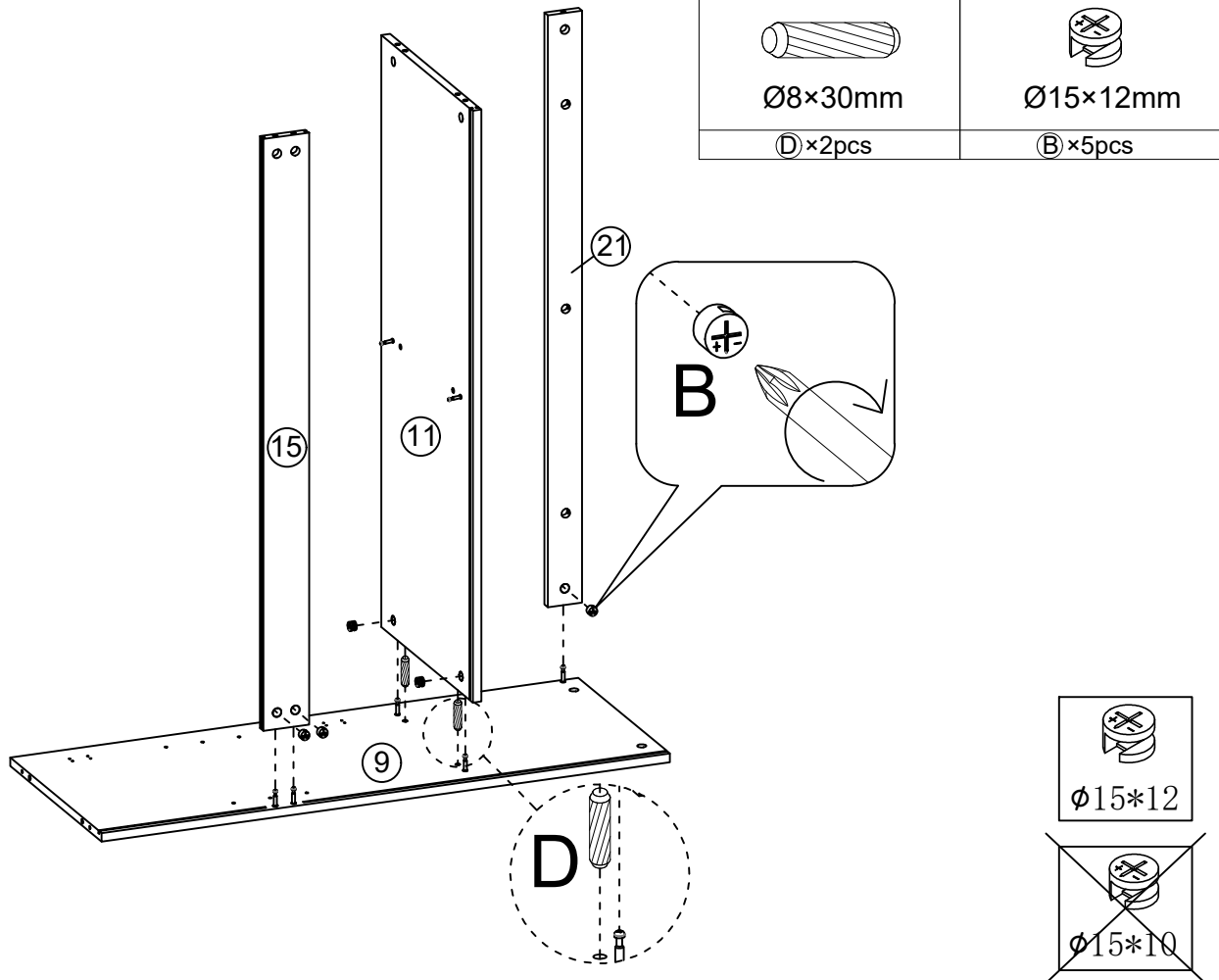

# Step 9 Schritt 9

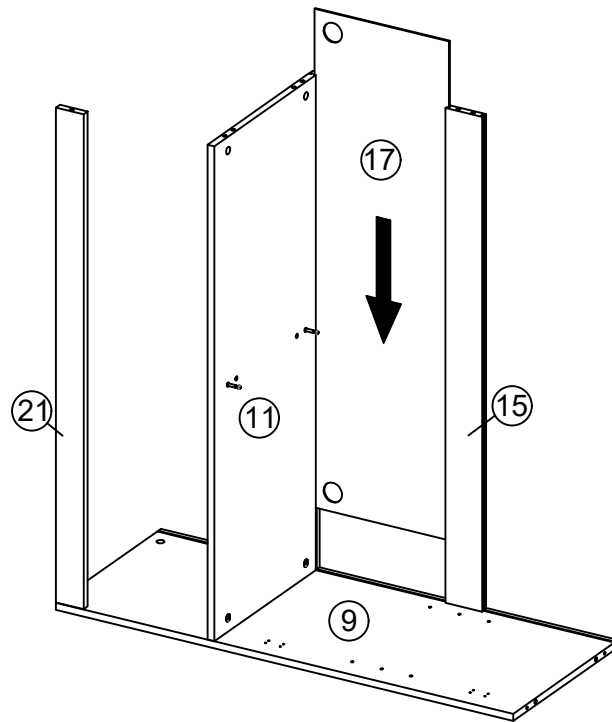

# Step 10 Schritt 10



Ø8×30mm

ⓓ×2pcs



Ø15×12mm

ⓑ×5pcs

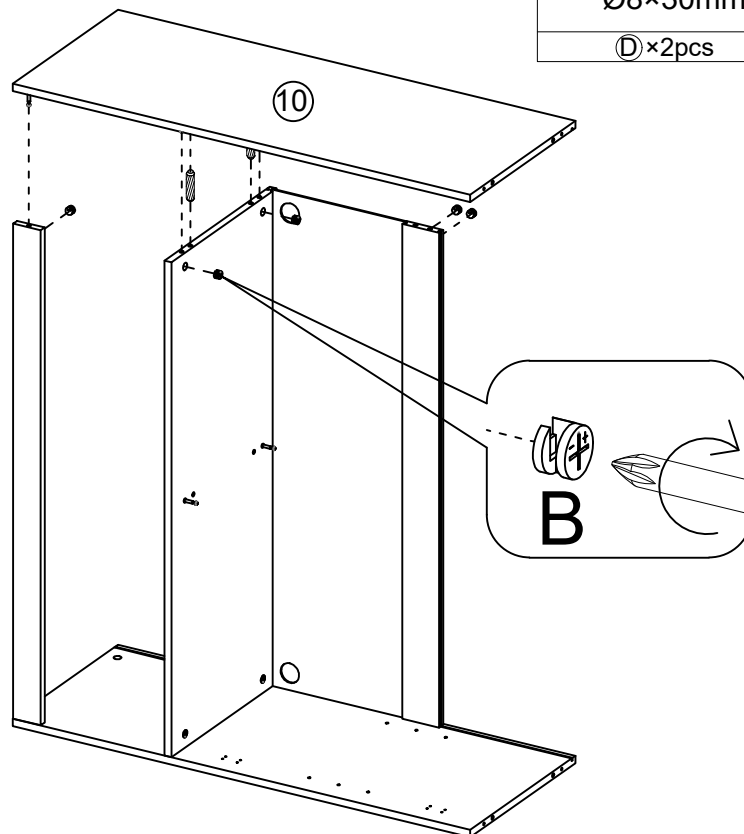

Ø15\*12

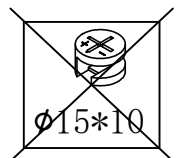

~~Ø15\*10~~

Step 11  
Schritt 11

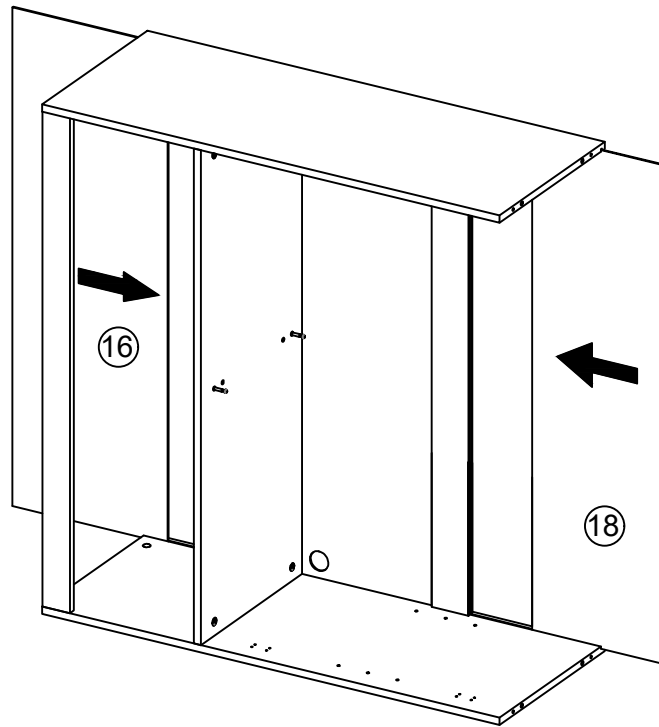

Step 12  
Schritt 12



Ø8×30mm

ⓓ×6pcs



Ø15×12mm

ⓑ×7pcs

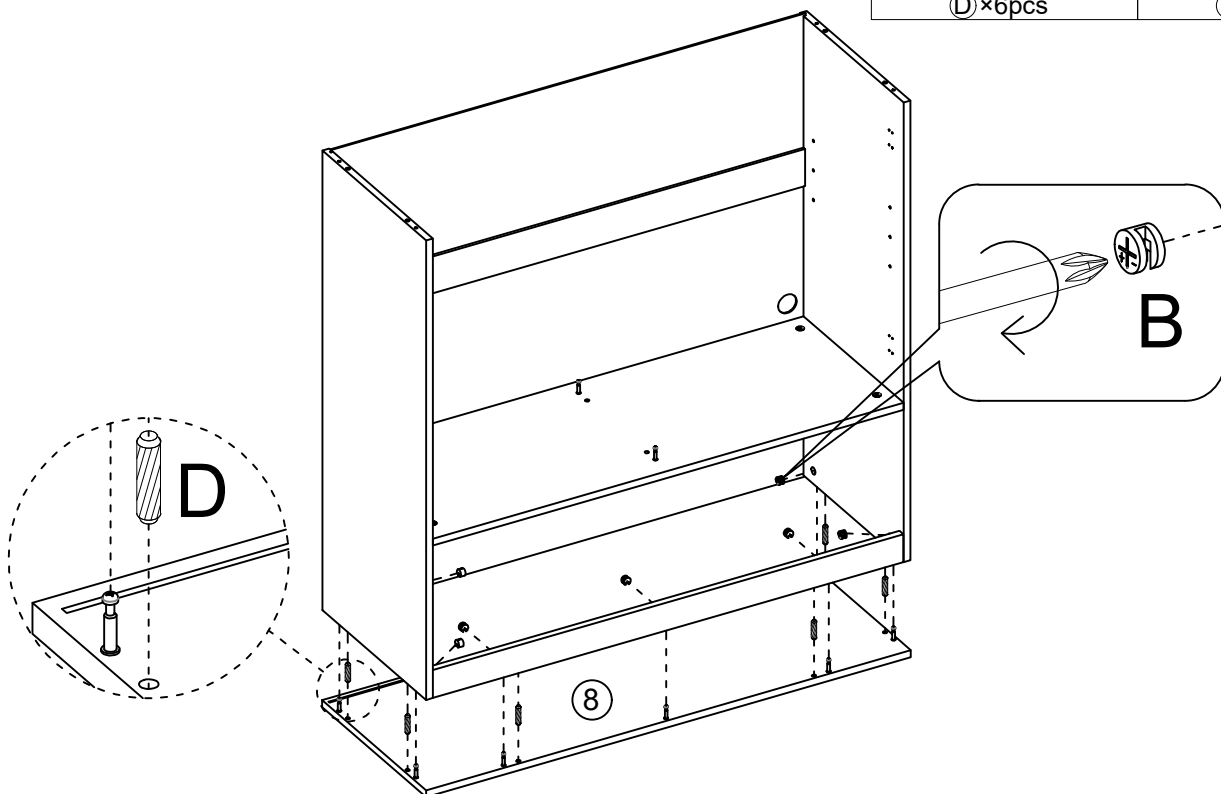

Ø15\*12

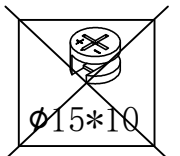

Ø15\*10

# Step 13 Schritt 13



Ø8×30mm

ⓓ×2pcs



Ø15×12mm

ⓑ×2pcs

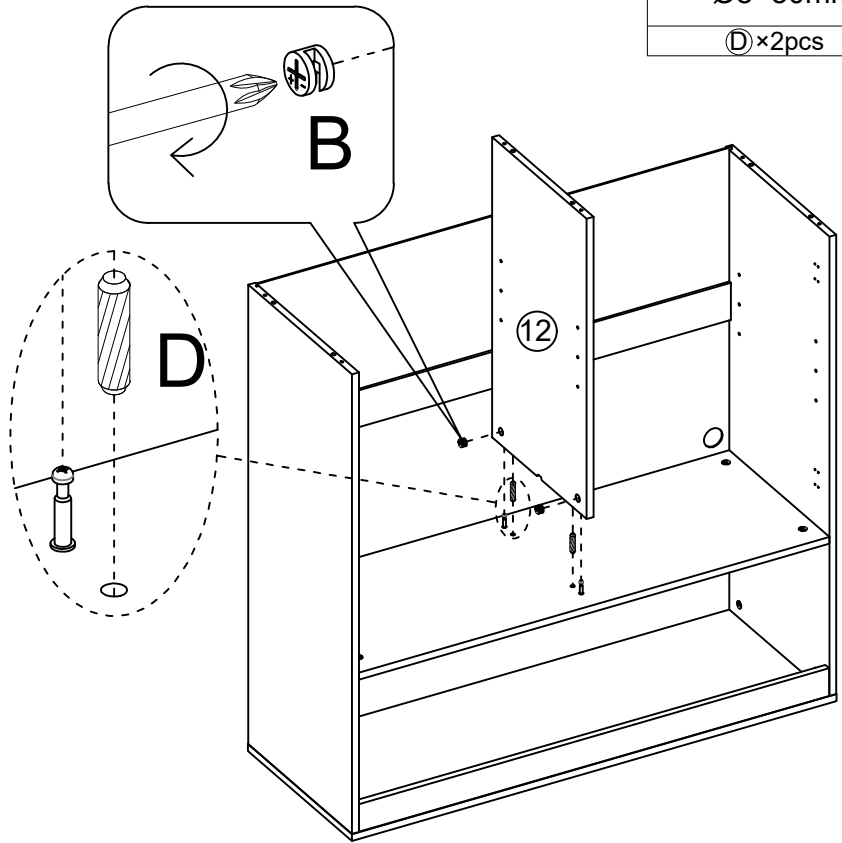

# Step 14 Schritt 14

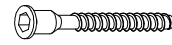

Ø7×40mm

ⓕ×6pcs



Ø8×30mm

ⓓ×6pcs

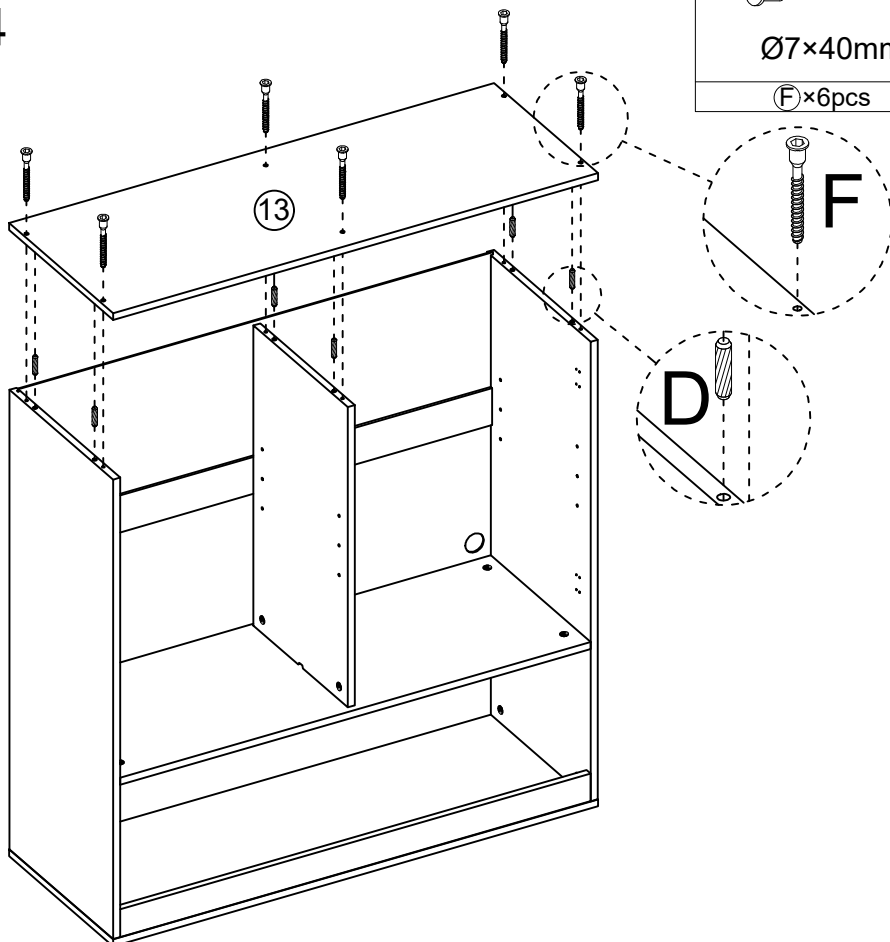

Step 15  
Schritt 15

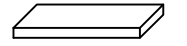

50×13×5mm

Ⓛ×4pcs

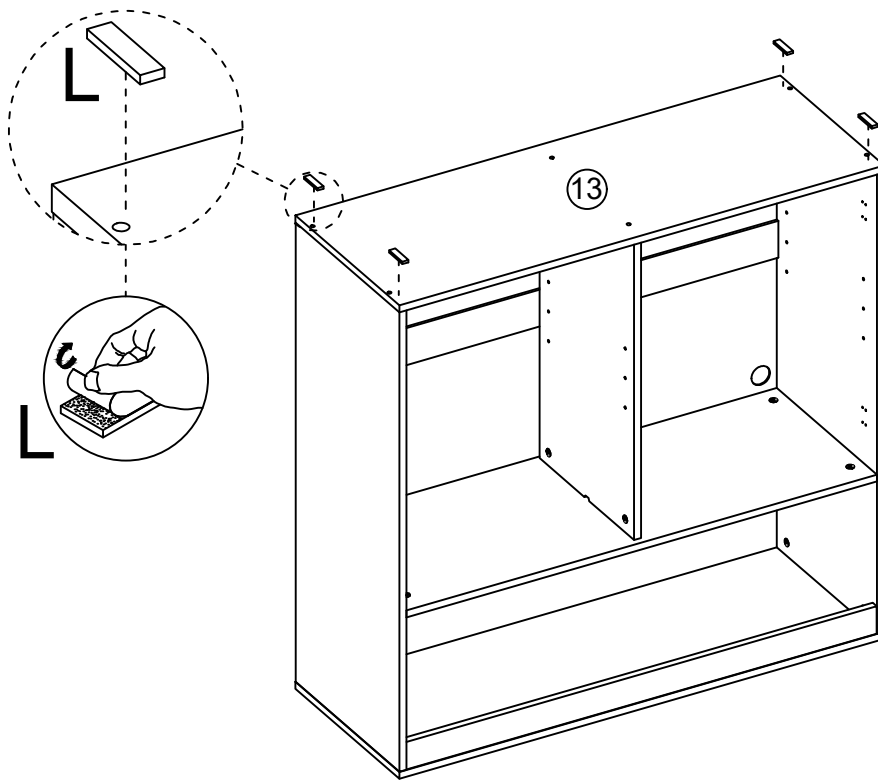

Step 16  
Schritt 16

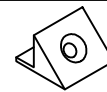

14×14×9mm

Ⓚ×6pcs



3.5×14mm

Ⓢ×6pcs

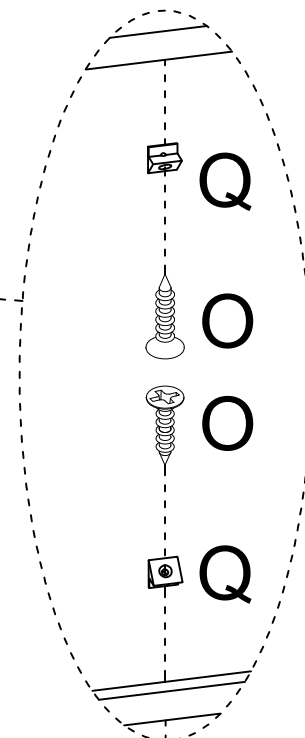
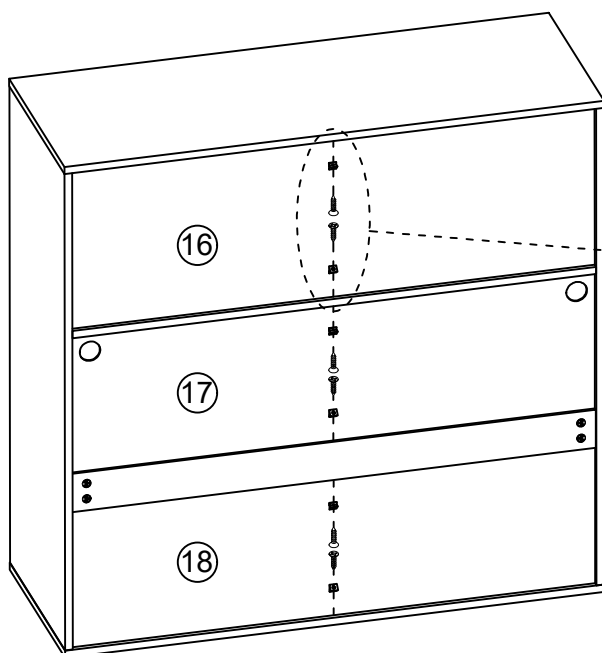

Step 17  
Schritt 17



Ø5x14mm



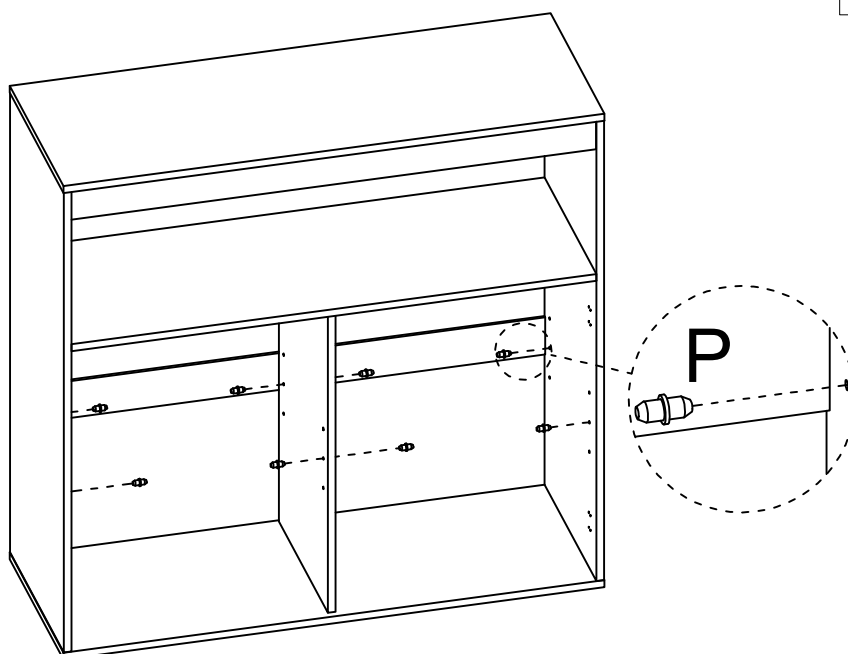

(P) x8pcs

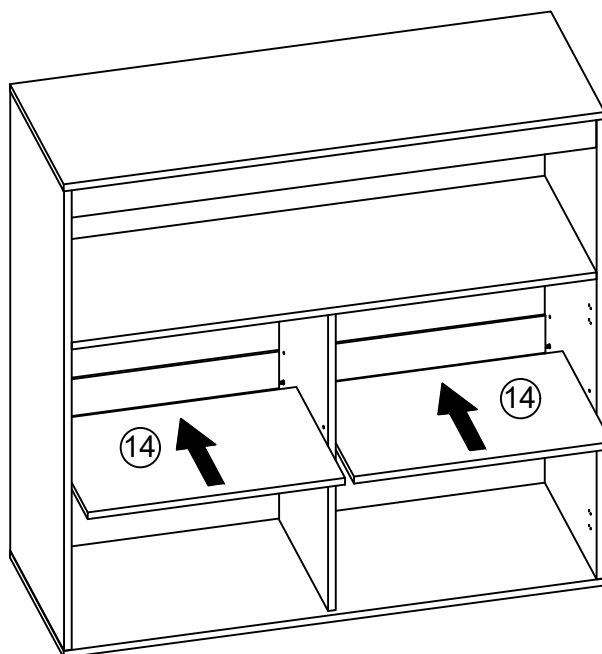

Step 18  
Schritt 18



# Step 19 Schritt 19

		 4×20mm	 3.5×14mm
Ⓛ ×4pcs	ⓔ ×2pcs	ⓖ ×2pcs	Ⓞ ×8pcs

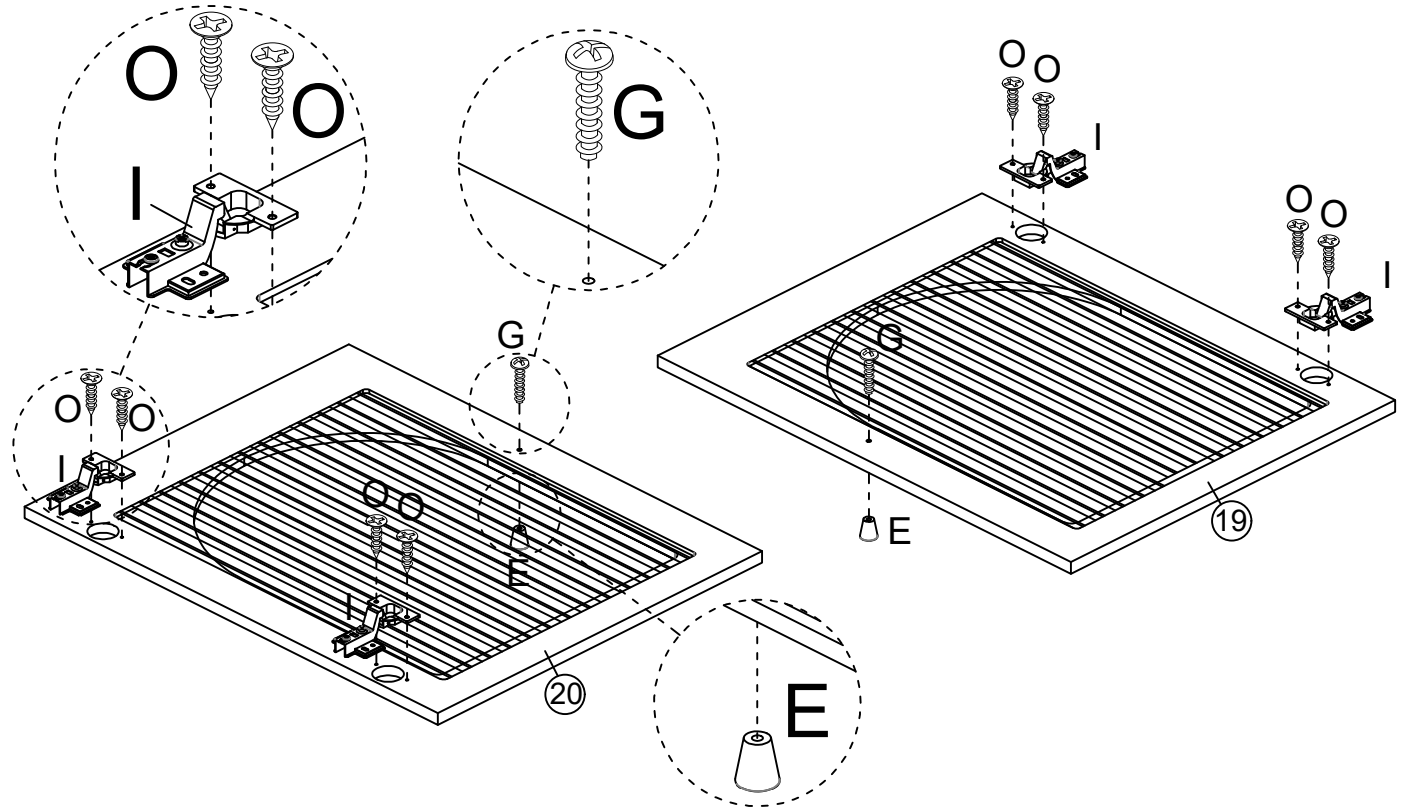

# Step 20 Schritt 20

 3.5×14mm
Ⓞ ×8pcs

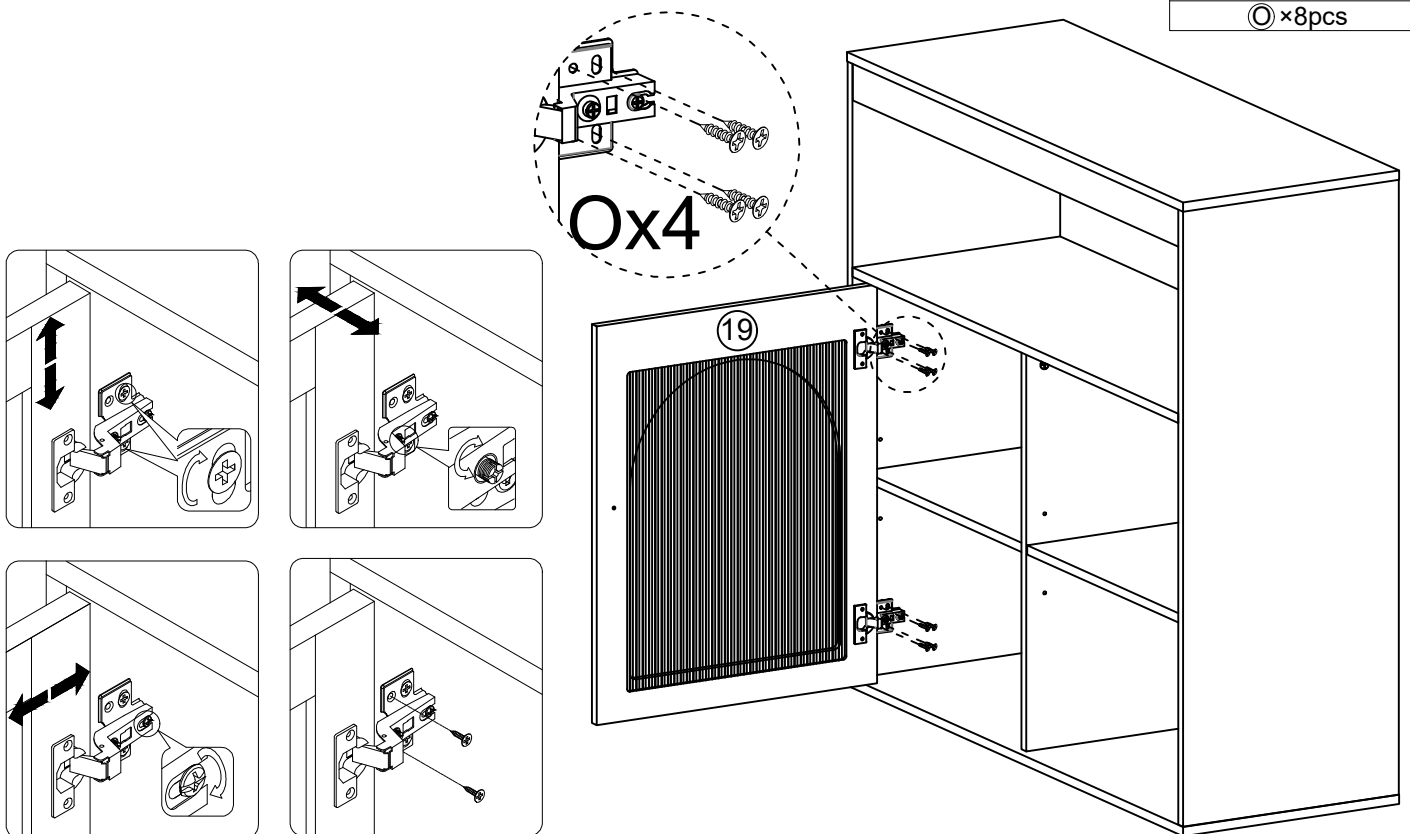

Step 21  
Schritt 21



3.5×14mm

⊙×8pcs

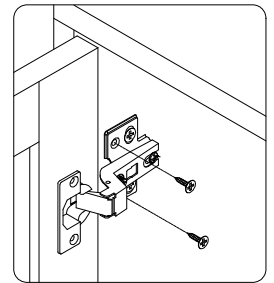
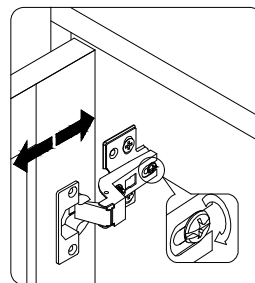
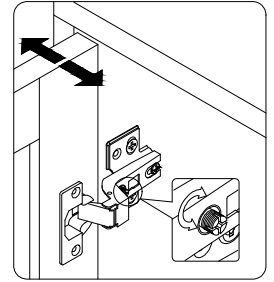
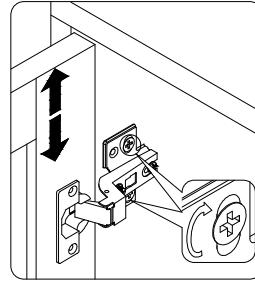
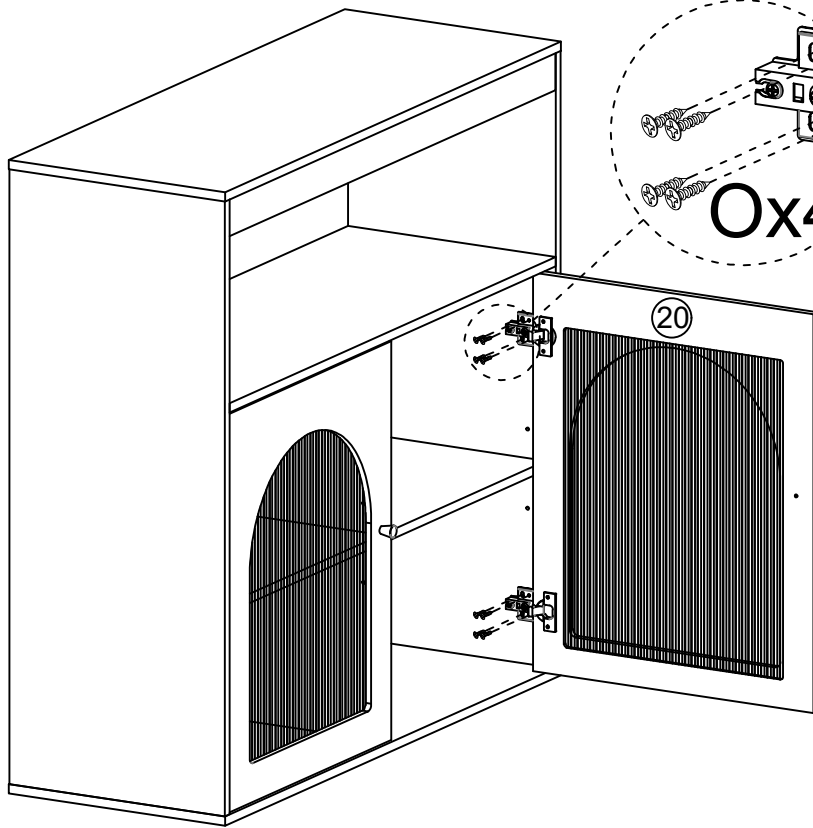

Step 22  
Schritt 22

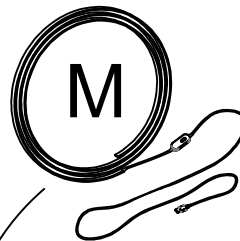
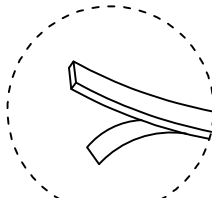

N×2pcs



M×1pc

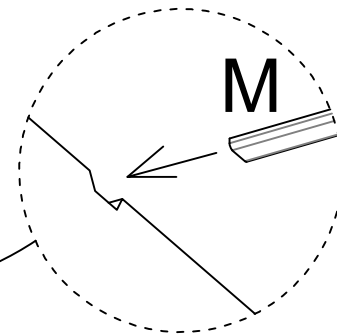
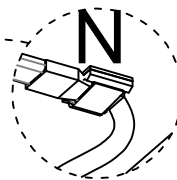
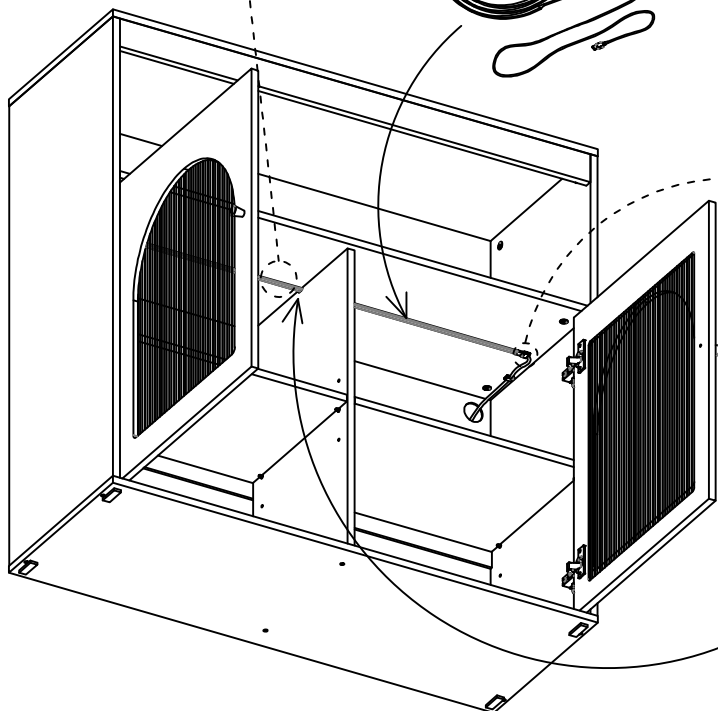

Step 23  
Schritt 23

