

# ASSEMBLY INSTRUCTIONS

## PART LIST

(A) Back assembly  
(1pc)



(B) Front legs-(2pcs)  
put inside the  
seat cushion



(C) Back legs-(2pcs)  
put inside the seat  
cushion

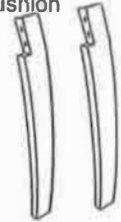

DO NOT FULLY TIGHTEN SCREWS AND BOLTS UNTIL THE ENTIRE ITEM IS COMPLETELY ASSEMBLED

NOTICE

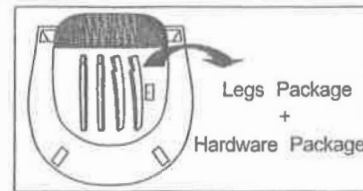

STEP 1

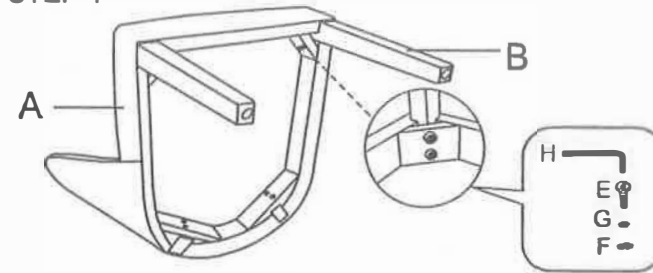



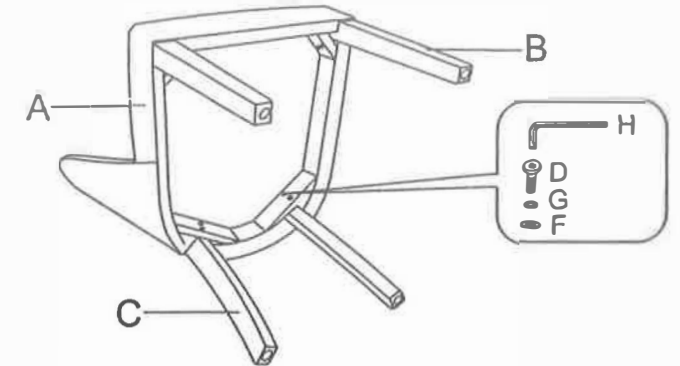

Step1:Put the screws in the holes,tighten the screws,but not too tighten,90% is ok.

STEP 2



Step 2:Put the screws in the holes,tighten the screws,but not too tighten,80% is ok.

## HARDWARE LIST

Screw D	Screw E	Flat washer F
		
(1) M8X55MM (4PCS)	(2) M8X70MM (4PCS)	(3) 8pcs
Spring washer G	Allen key H	
		
(4) 8pcs	M8 (5) 1PC	

STEP 3

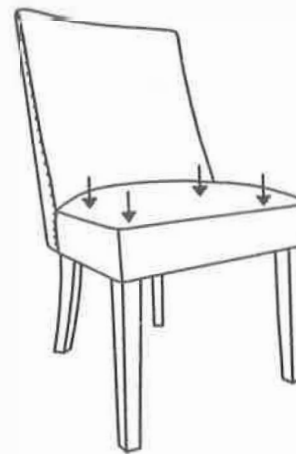

Step 3: Then adjust the balance of this chair,tighten all the screws to100%.

STEP 4

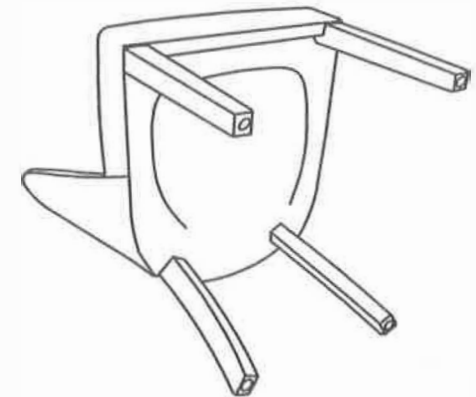

Step4 :Finally,zip up the non-woven cover underneath the seat.