

# ASSEMBLY INSTRUCTION

INSTRUCTIONS DE MONTAGE

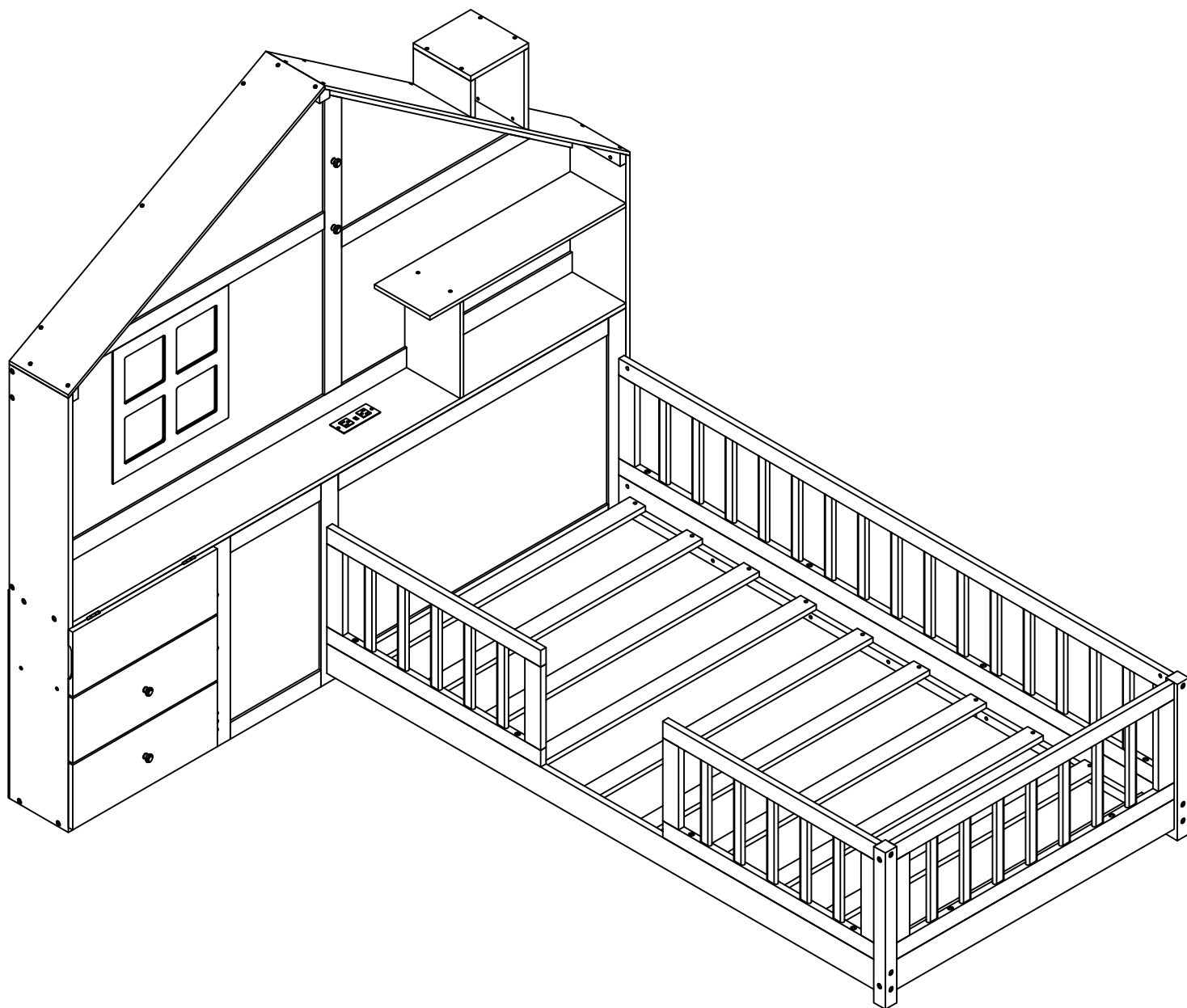



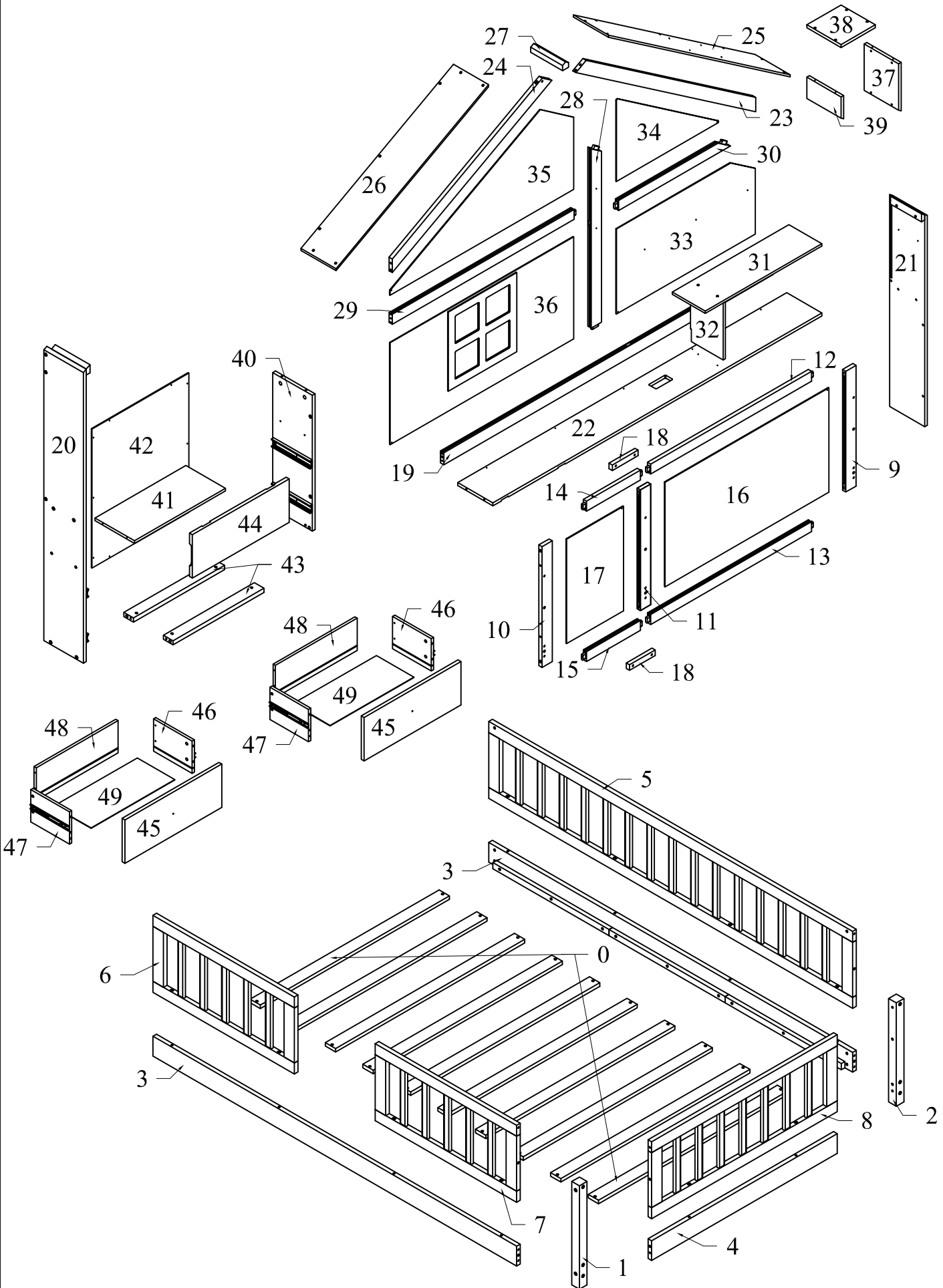

# ASSEMBLY INSTRUCTION

## INSTRUCTIONS DE MONTAGE



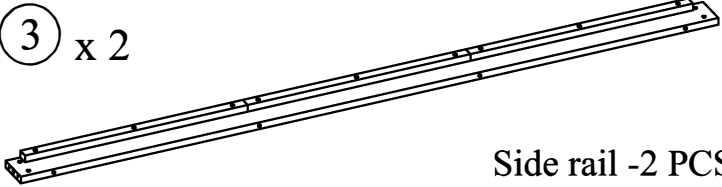
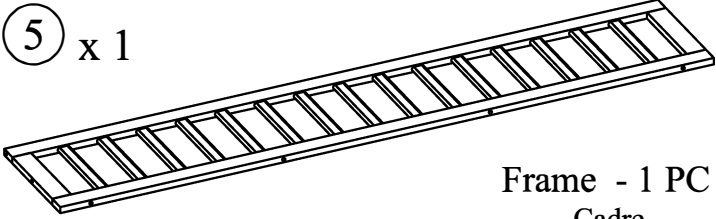
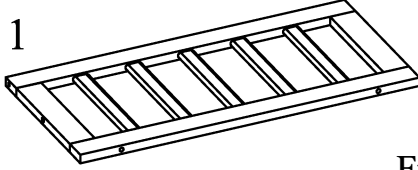
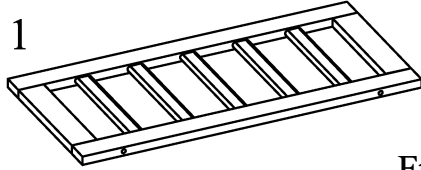
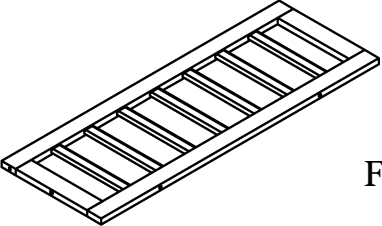
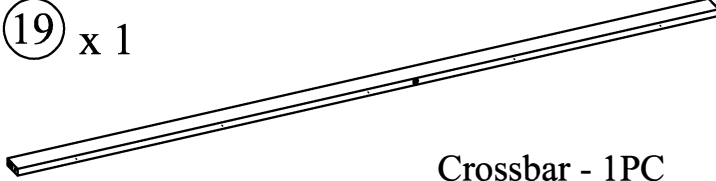
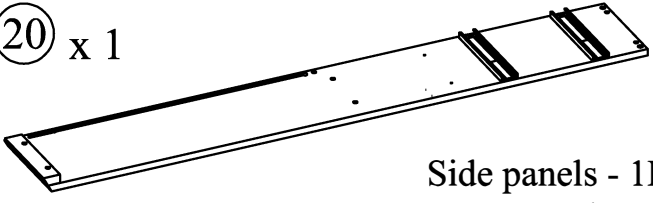
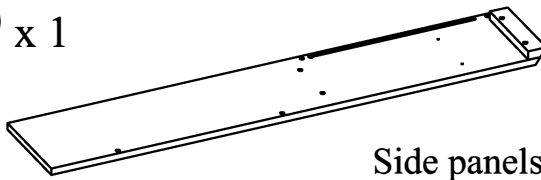
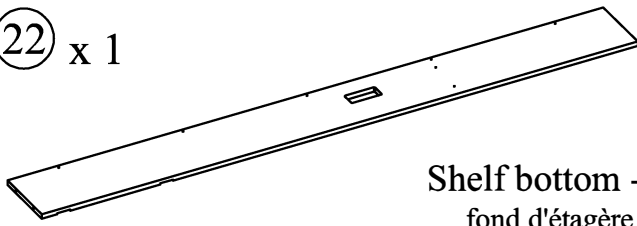
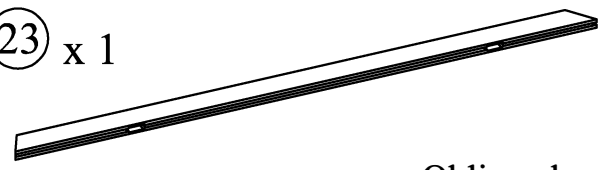
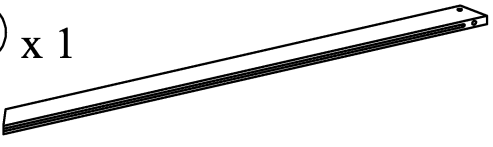
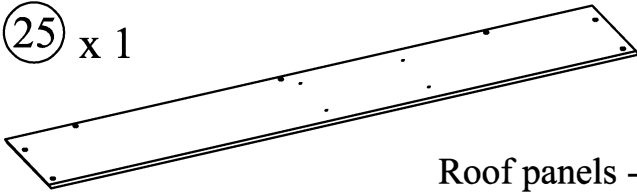
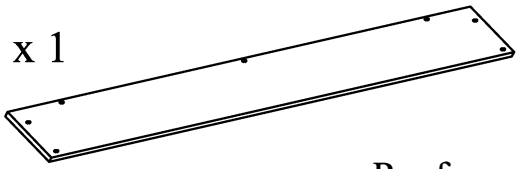





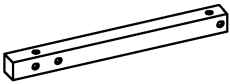
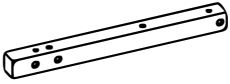
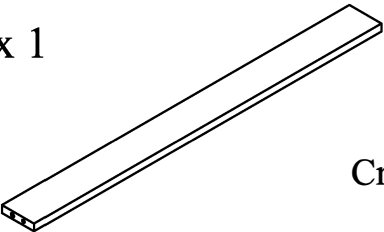
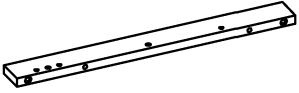
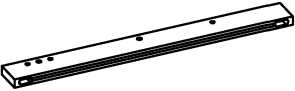
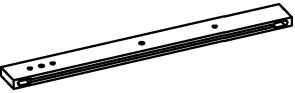

# Part List & Hardware List ( Box 1 )

Liste des pièces & Liste du matériel ( boîte 1)

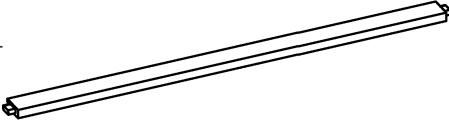
<p>③ x 2</p>  <p>Side rail - 2 PCS Barrière latérale</p>	<p>⑤ x 1</p>  <p>Frame - 1 PC Cadre</p>	
<p>⑥ x 1</p>  <p>Frame - 1 PC Cadre</p>	<p>⑦ x 1</p>  <p>Frame - 1 PC Cadre</p>	
<p>⑧ x 1</p>  <p>Frame - 1 PC Cadre</p>	<p>⑱ x 1</p>  <p>Crossbar - 1PC Barre transversale</p>	
<p>⑳ x 1</p>  <p>Side panels - 1PC panneaux latéraux</p>	<p>㉑ x 1</p>  <p>Side panels - 1PC panneaux latéraux</p>	
<p>㉒ x 1</p>  <p>Shelf bottom - 1PC fond d'étagère</p>	<p>㉓ x 1</p>  <p>Oblique bar - 1PC barre oblique</p>	
<p>㉔ x 1</p>  <p>Oblique bar - 1PC barre oblique</p>	<p>㉕ x 1</p>  <p>Roof panels - 1PC Panneaux de toit</p>	
<p>㉖ x 1</p>  <p>Roof panels - 1PC Panneaux de toit</p>	<p>㉙ x 1</p>  <p>Crossbar - 1PC Barre transversale</p>	
<p>⑳ x 1</p>  <p>Crossbar - 1PC Barre transversale</p>	<p>④⑥ x 2</p>  <p>Side Drawers - 2PCS Tiroirs latéraux</p>	<p>④⑦ x 2</p>  <p>Side Drawers - 2PCS Tiroirs latéraux</p>

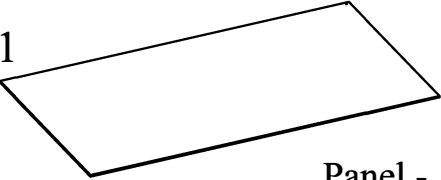



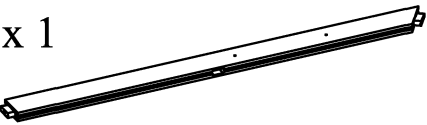
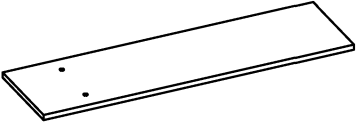



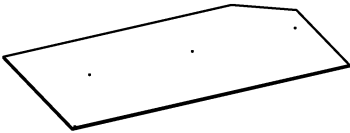

# Part List ( Box 2 )

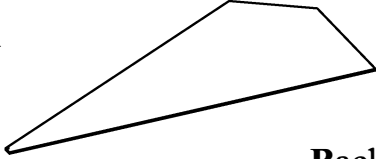
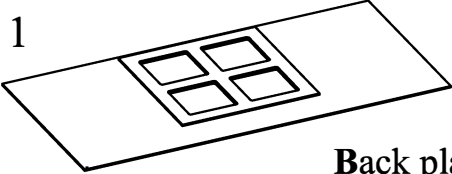
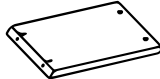
Liste des pièces ( boîte 2 )

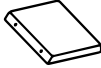
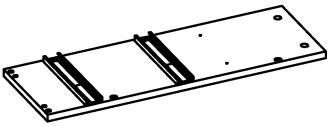
<p>① x 1</p>  <p>Leg -1 PC Jambe</p>	<p>② x 1</p>  <p>Leg -1 PC Jambe</p>
<p>④ x 1</p>  <p>Crossbar - 1PC Barre transversale</p>	<p>⑨ x 1</p>  <p>Leg -1 PC Jambe</p>
<p>⑩ x 1</p>  <p>Leg -1 PC Jambe</p>	<p>⑪ x 1</p>  <p>Vertical bar -1 PC Barre verticale</p>
<p>⑫ x 1</p>  <p>Crossbar - 1PC Barre transversale</p>	<p>⑬ x 1</p>  <p>Crossbar - 1PC Barre transversale</p>
<p>⑭ x 1</p>  <p>Crossbar - 1PC Barre transversale</p>	<p>⑮ x 1</p>  <p>Crossbar - 1PC Barre transversale</p>
<p>⑯ x 1</p>  <p>Panel - 1PC panneau</p>	<p>⑰ x 1</p>  <p>Panel - 1PC panneau</p>
<p>⑱ x 2</p>  <p>Link bar - 2PCS barre de liens</p>	<p>⑳ x 1</p>  <p>Roof support bar - 1PC barre de support de toit</p>
<p>㉘ x 1</p>  <p>Vertical bar -1 PC Barre verticale</p>	<p>㉙ x 1</p>  <p>Shelf plate - 1PC plaque d'étagère</p>

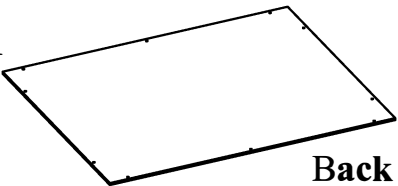

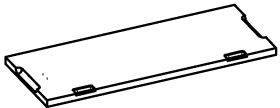
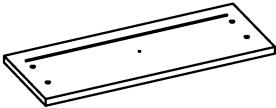

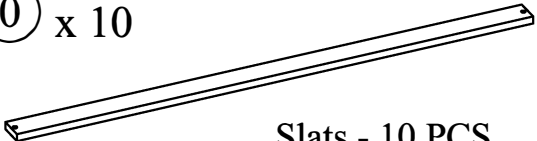





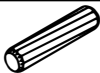

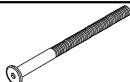
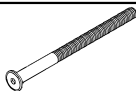

# Part List ( Box 2 )

Liste des pièces ( boîte 2 )

<p>③② x 1</p>  <p><b>Shelf plate - 1PC</b> plaque d'étagère</p>	<p>③③ x 1</p>  <p><b>Back plate- 1PC</b> plaque arrière</p>	
<p>③④ x 1</p>  <p><b>Back plate- 1PC</b> plaque arrière</p>	<p>③⑤ x 1</p>  <p><b>Back plate- 1PC</b> plaque arrière</p>	
<p>③⑥ x 1</p>  <p><b>Back plate- 1PC</b> plaque arrière</p>	<p>③⑦ x 1</p>  <p><b>Upper plate- 1PC</b> Plaque supérieure</p>	
<p>③⑧ x 1</p>  <p><b>Upper plate- 1PC</b> Plaque supérieure</p>	<p>③⑨ x 1</p>  <p><b>Upper plate- 1PC</b> Plaque supérieure</p>	
<p>④① x 1</p>  <p><b>Side panels - 1PC</b> panneaux latéraux</p>	<p>④② x 1</p>  <p><b>Shelf - 1PC</b> étagère</p>	
<p>④③ x 1</p>  <p><b>Back plate - 1PC</b> Plaque arrière</p>	<p>④④ x 2</p>  <p><b>Crossbar - 2PCS</b> Barre transversale</p>	
<p>④⑤ x 1</p>  <p><b>Flip door - 1PC</b> porte rabattable</p>	<p>④⑥ x 2</p>  <p><b>Top Drawers - 2PCS</b> Tiroirs supérieurs</p>	
<p>④⑧ x 2</p>  <p><b>Back Drawers - 2PCS</b> Tiroirs arrière</p>	<p>④⑨ x 2</p>  <p><b>Bottom Drawers - 2PCS</b> Tiroirs inférieurs</p>	<p>① x 10</p>  <p><b>Slats - 10 PCS</b> Lattes</p>

# Hardware List ( Box 1 )

Liste du matériel ( boîte 1 )

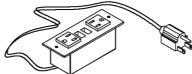
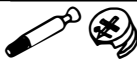



No.	OUTLOOK	DESC	QTY
(A)		Dowel Ø10*40mm Cheville	16
(B)		Bolts 1/4"*30mm Boulons	04
(C)		Bolts 1/4"*35mm Boulons	07
(D)		Bolts 1/4"*60mm Boulons	27
(E)		Bolts 1/4"*80mm Boulons	10
(F)		Bolts 1/4"*100mm Boulons	05
(G)		Bolts 1/4"*110mm Boulons	01
(H)		Screws Ø6.5*70mm Des vis	02
(I)		Cross dowel 1/4"*13mm Cheville croisée	33
(J)		Round head screw #7*15mm Vis à tête ronde	10
(K)		Round head screw #7*25mm Vis à tête ronde	03
(L)		Screws #6*12mm Des vis	08
(M)		Screws #7*15mm Des vis	18
(N)		Screws #8*25mm Des vis	14
(O)		Screws #8*30mm Des vis	29
(P)		Screws #8*40mm Des vis	22
(Q)		Knob Bouton	04
(R)		Power Outlet Prise de courant	01
(S)		Connector Housing Boîtier de connecteur	10

ASSEMBLY TOOLS REQUIRED (NOT INCLUDED)/OUTILS D'ASSEMBLAGE REQUIS (NON INCLUS)



# Hardware List ( Box 1 )

Liste du matériel ( boîte 1 )

No.	OUTLOOK	DESC	QTY
(T)		Base L small Base L petite	03
(U)		Flap lift system for cabinets Système de levage d'ailerons pour armoires	01
(V)		Door Hinge Charnière de porte	02
(W)		Allen key 60*22*4mm clé Allen	01

ASSEMBLY TOOLS REQUIRED (NOT INCLUDED)/OUTILS D'ASSEMBLAGE REQUIS (NON INCLUS)



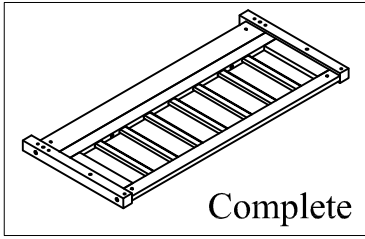

# STEP 1

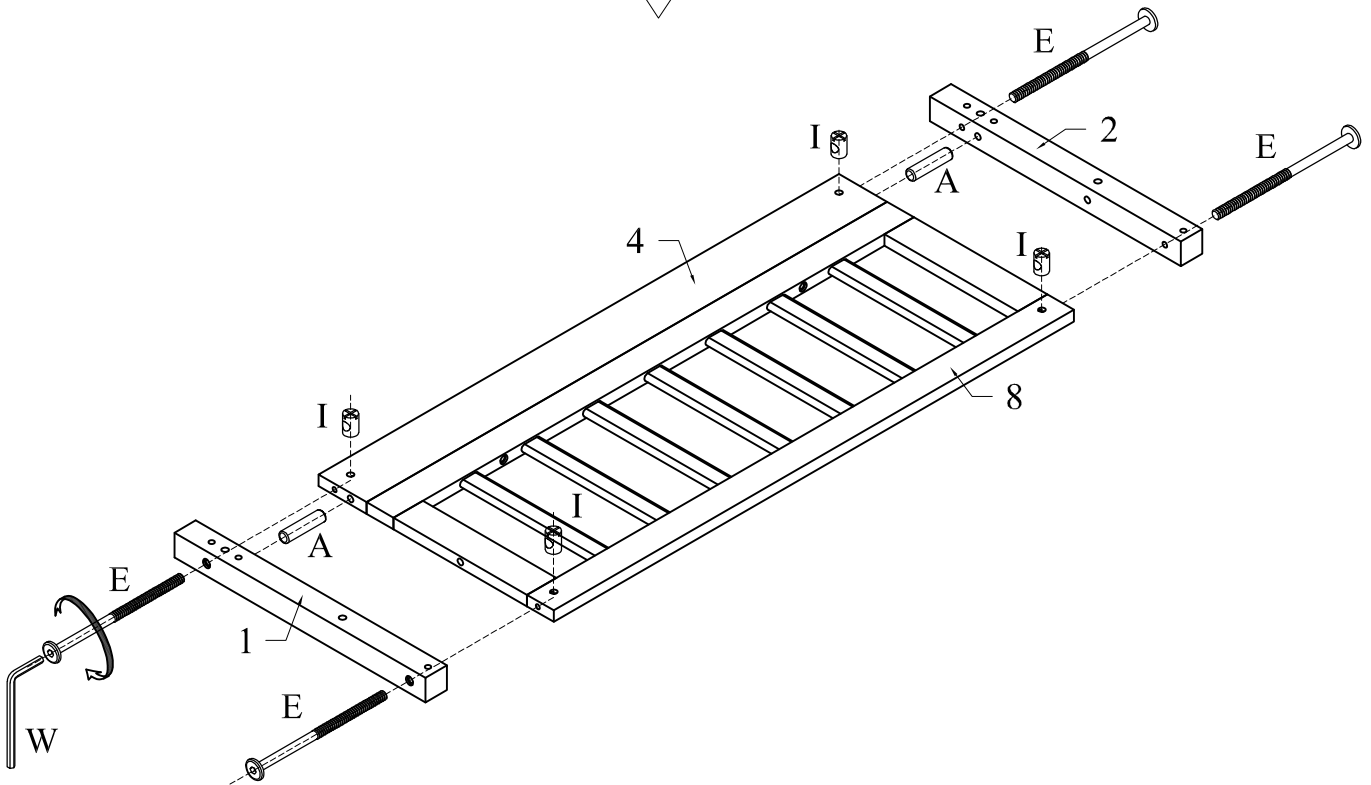
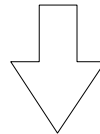
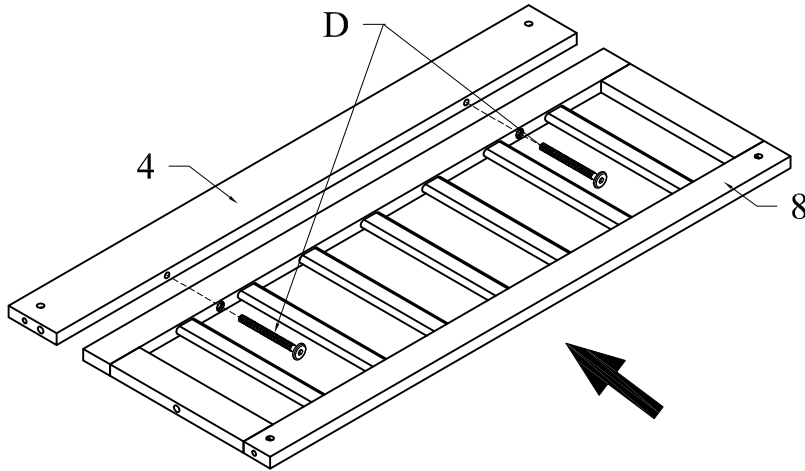

(A)		02
(D)		02
(E)		04
(I)		04



# STEP 2

(F)		04
(I)		04

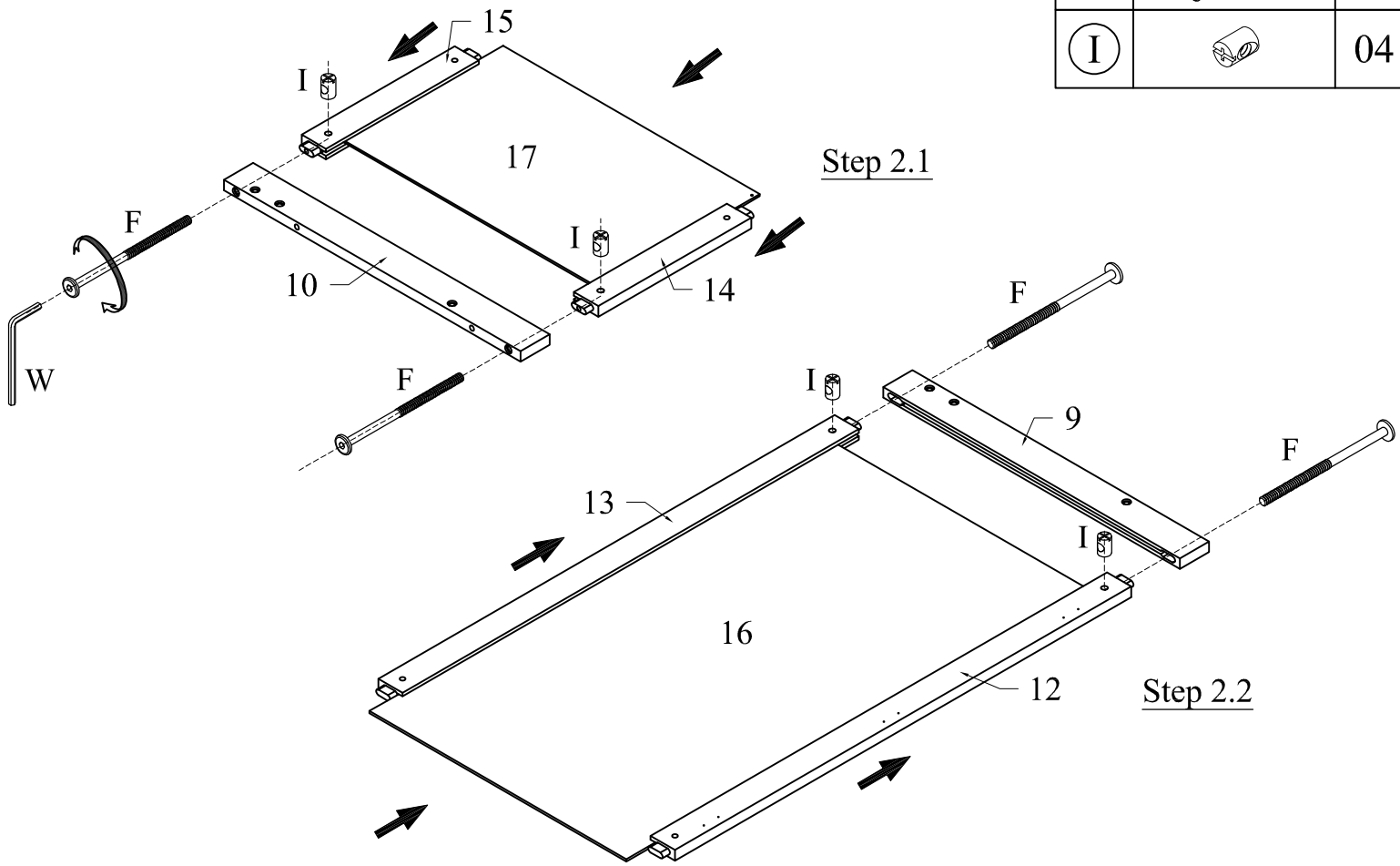

# STEP 3

(B)		04
-----	---	----

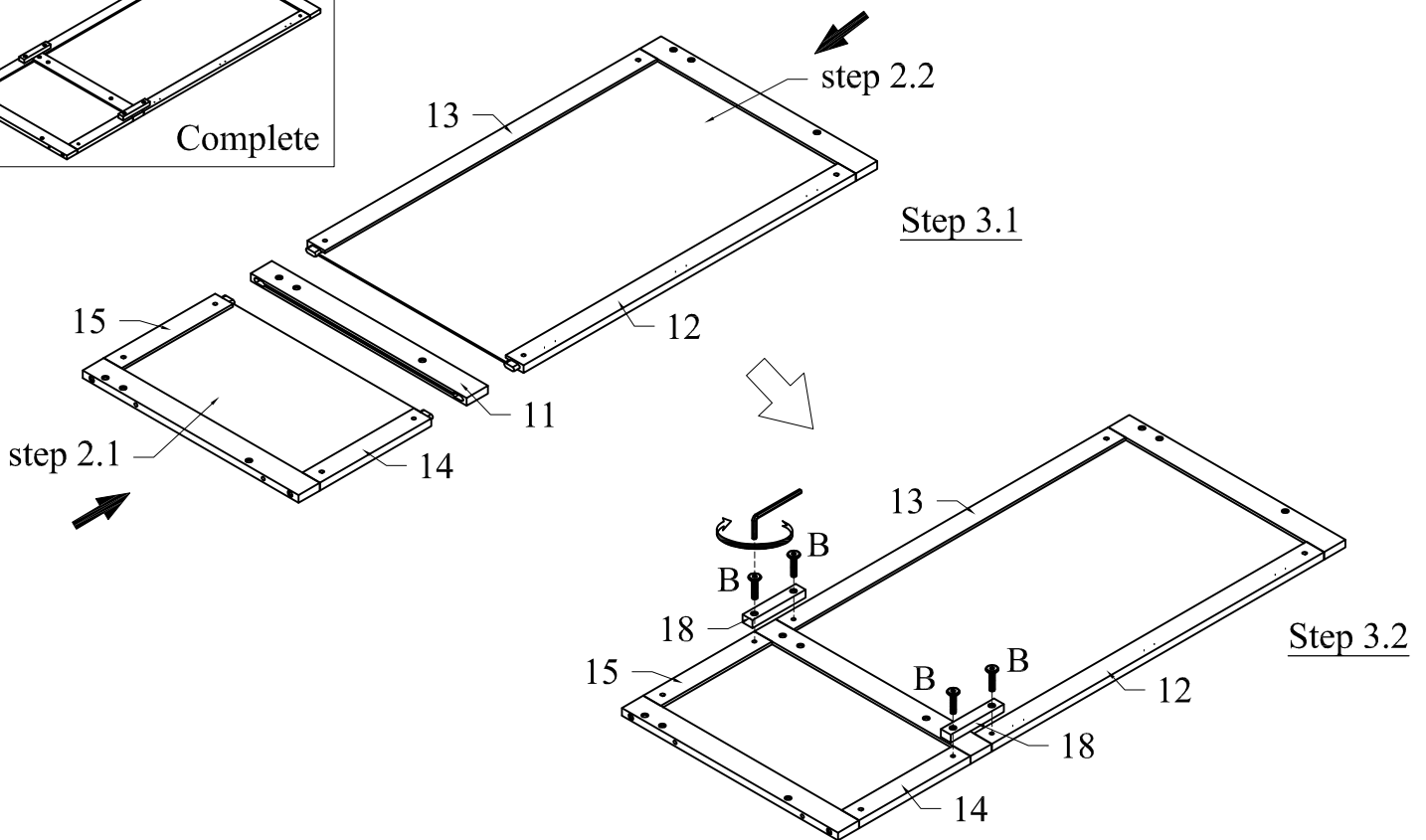
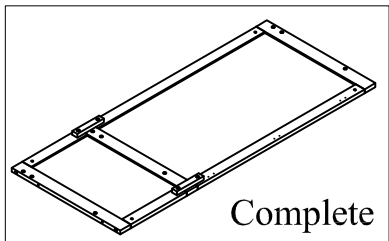

# STEP 4

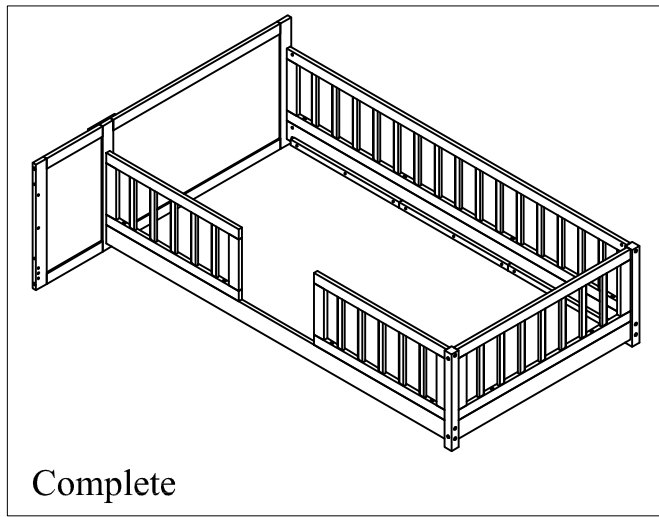

(A)		08
(D)		14
(E)		06
(I)		12

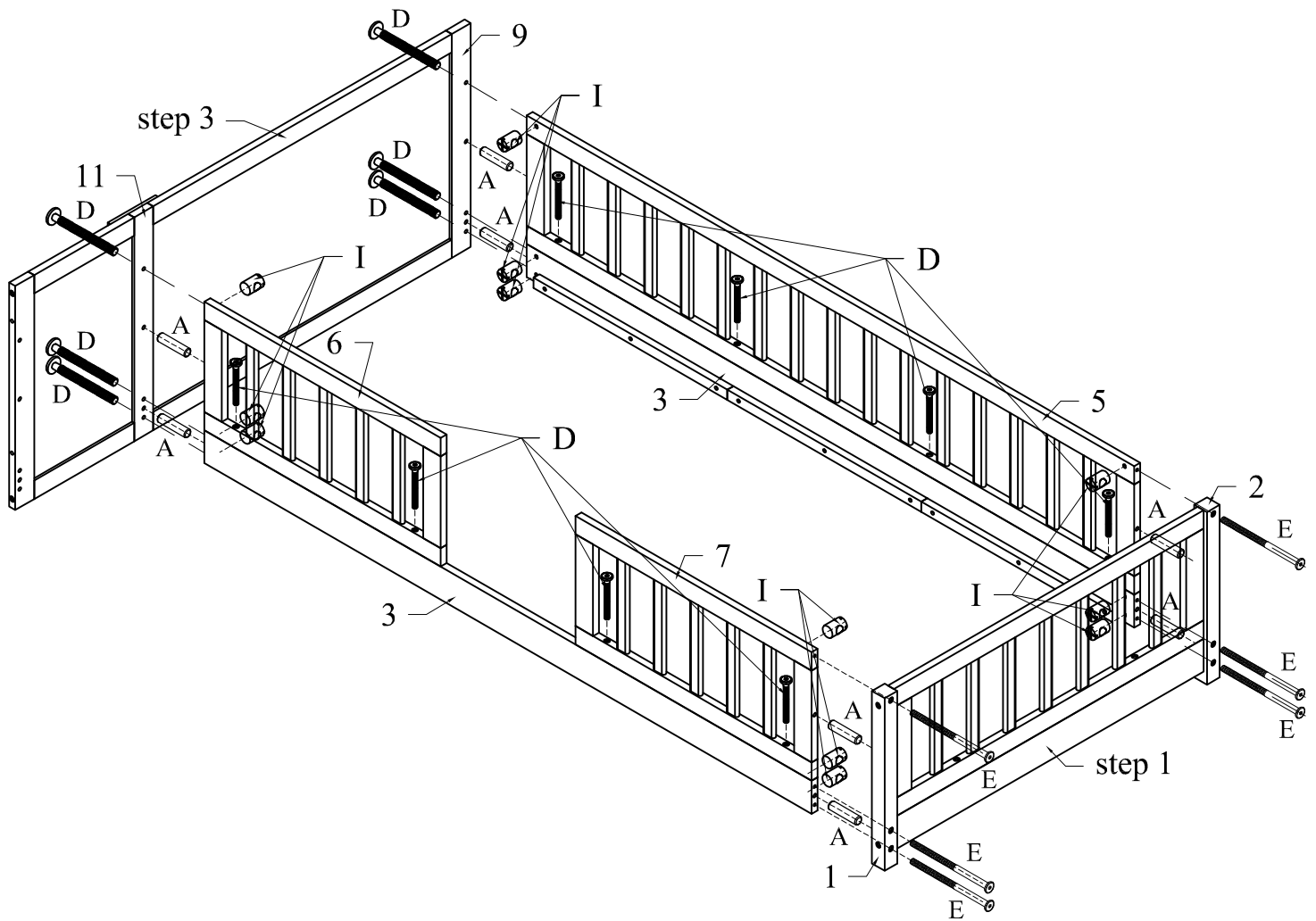

# STEP 5

⊙		20
---	--	----

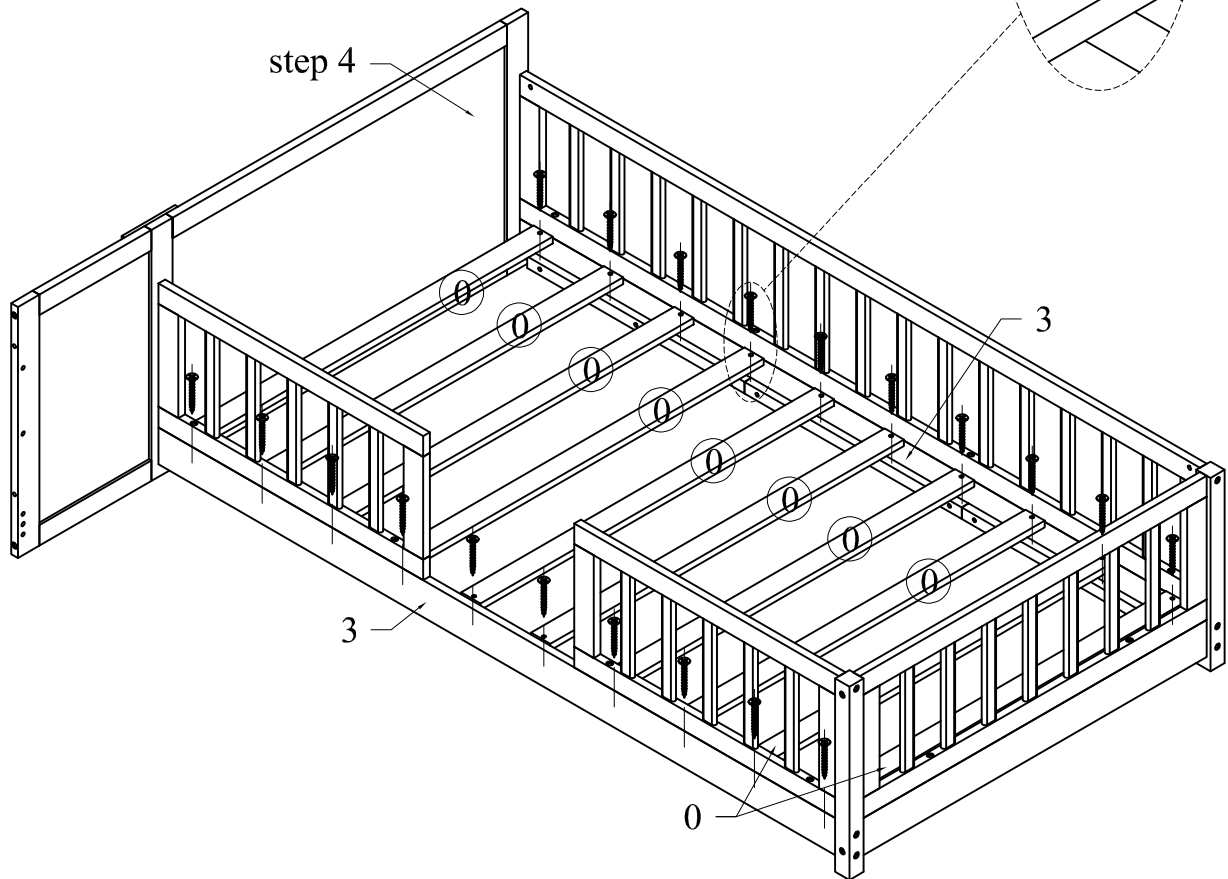
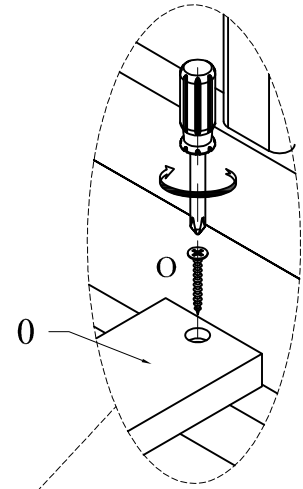
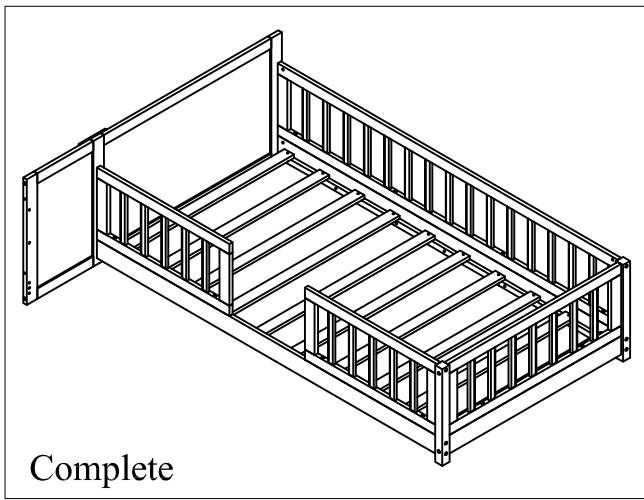



# STEP 7

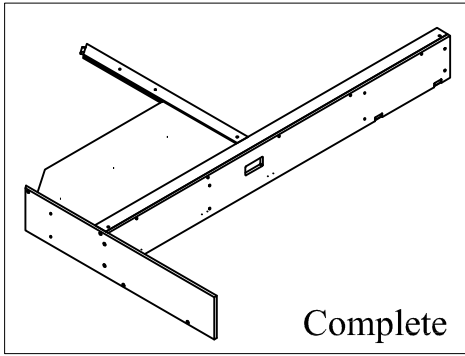

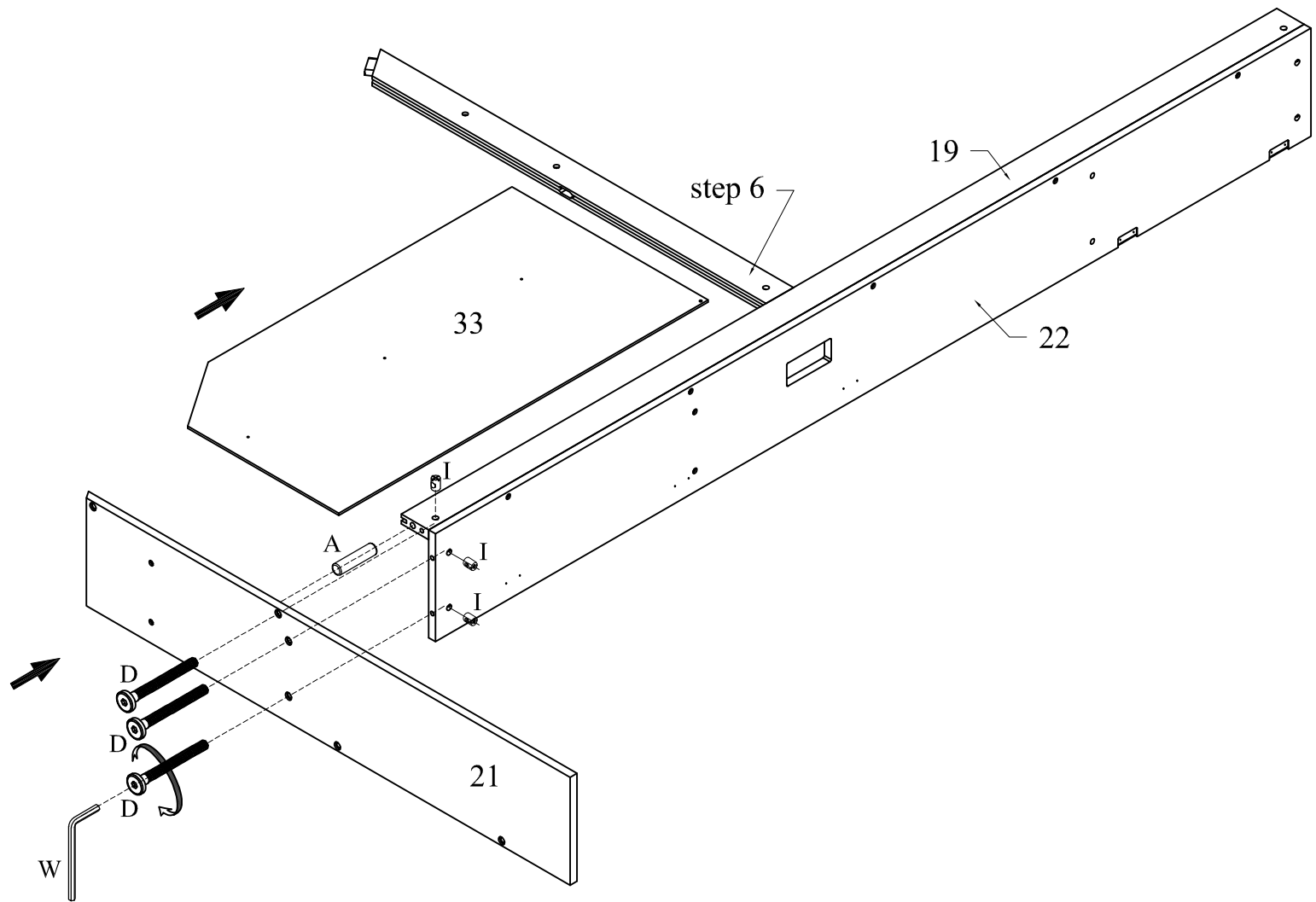

(A)		01
(D)		03
(I)		03

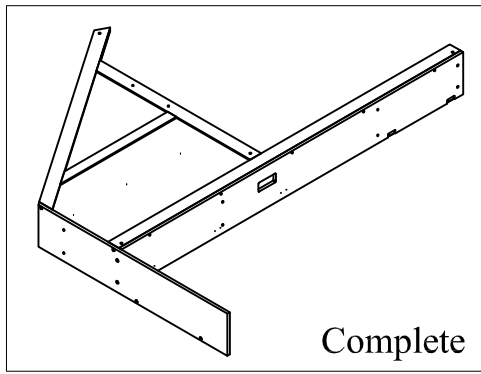

# STEP 8



(C)		01
(H)		02

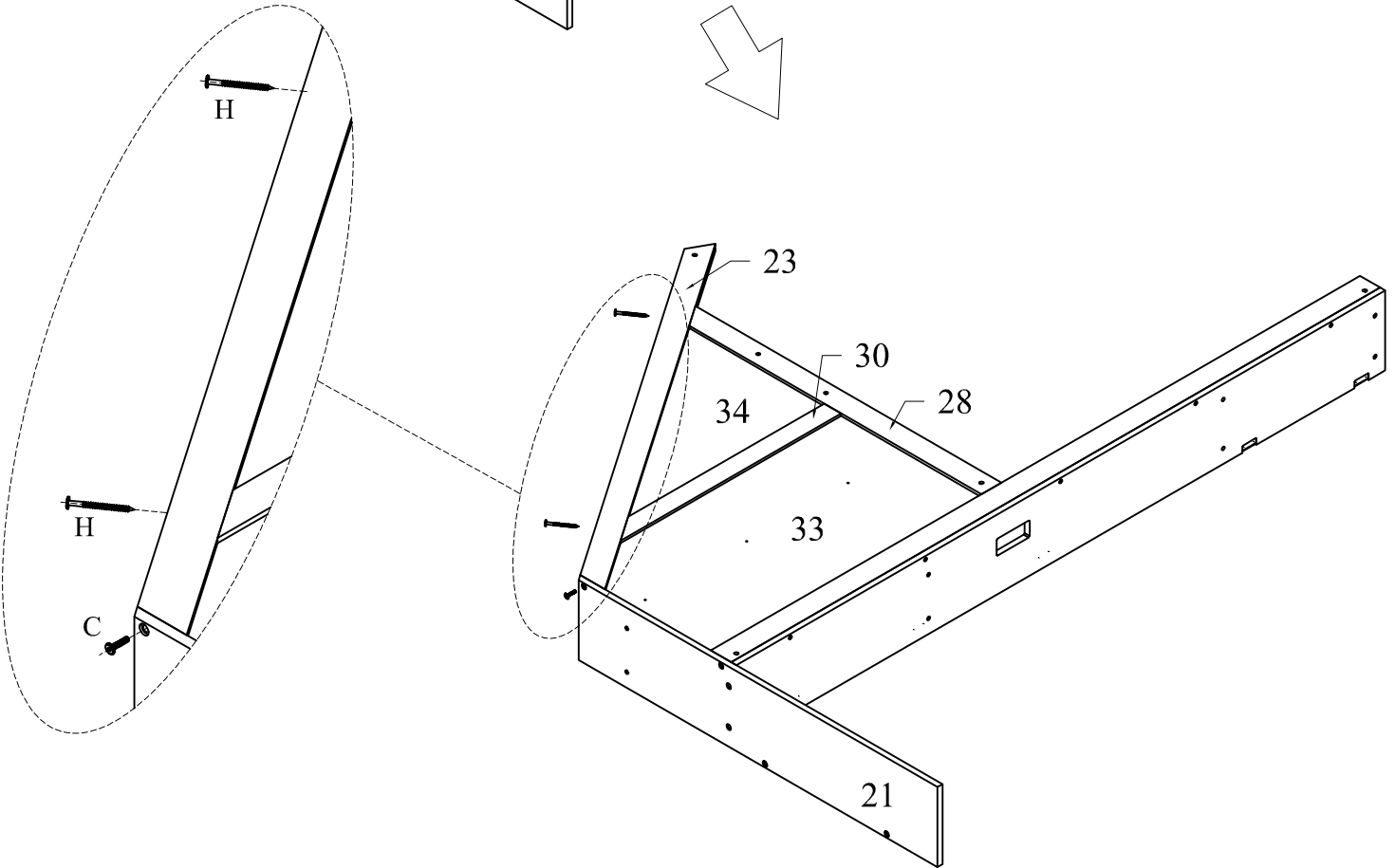
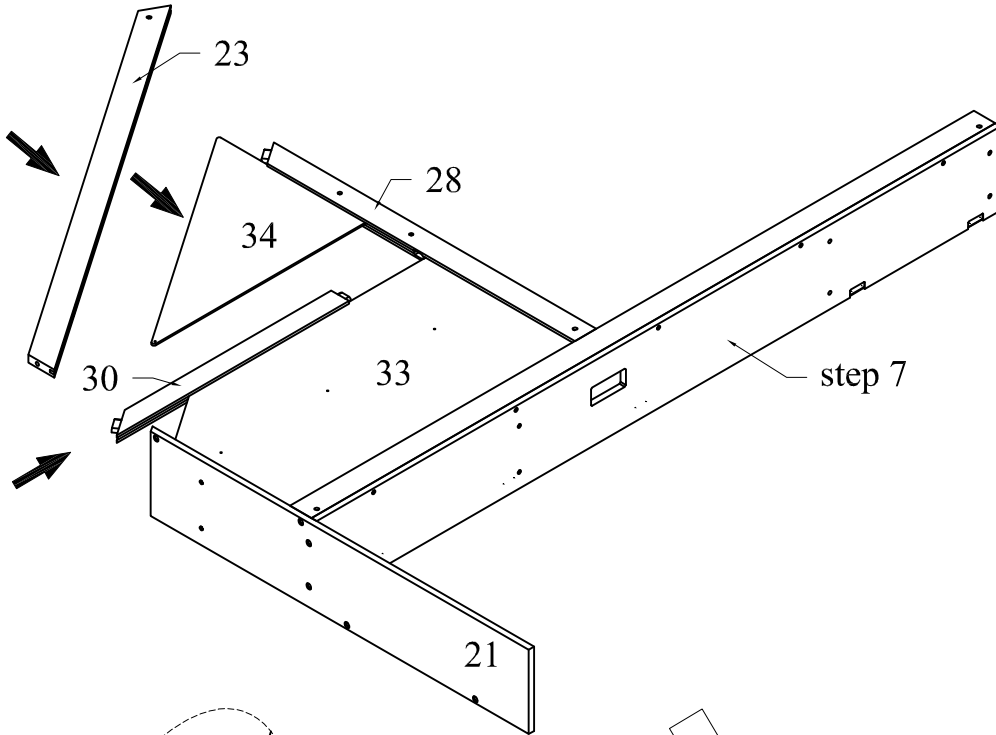

# STEP 9

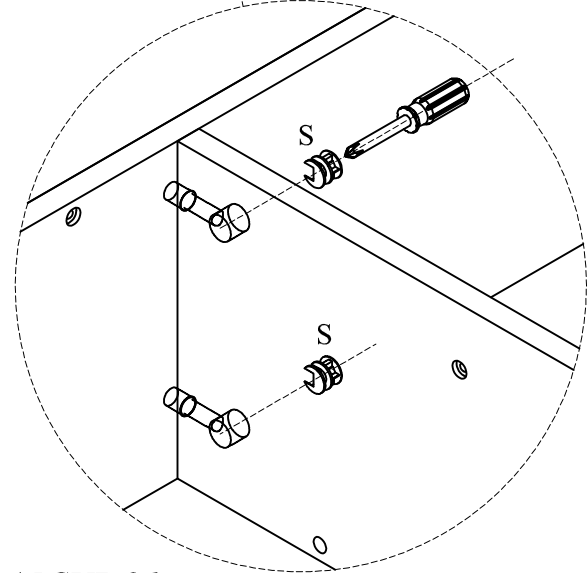
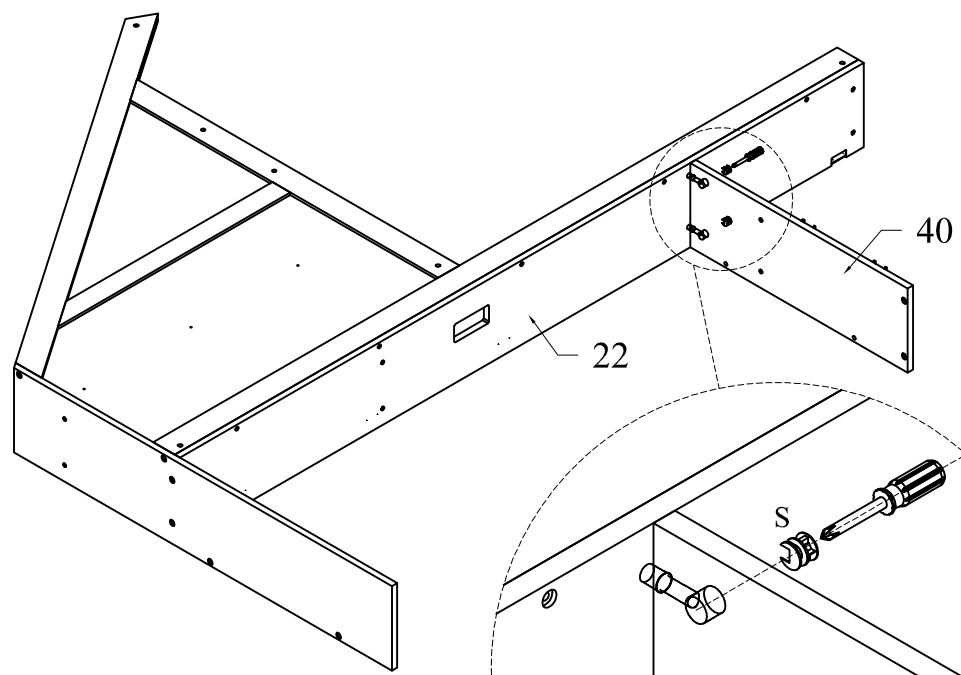
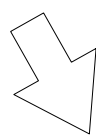
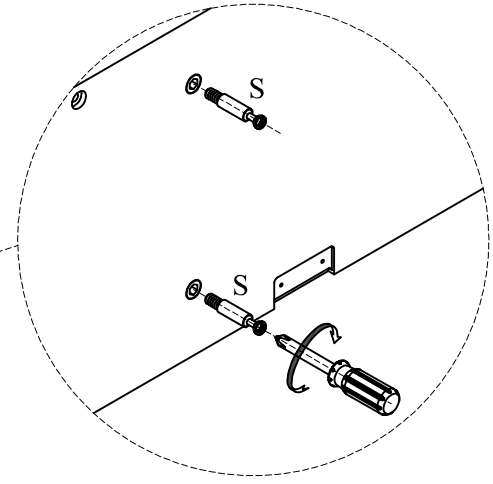
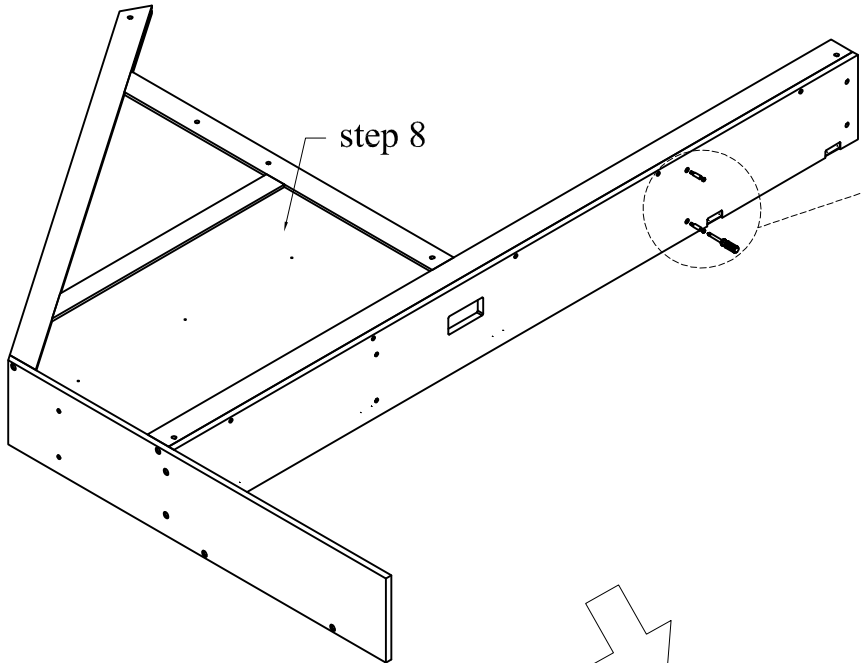
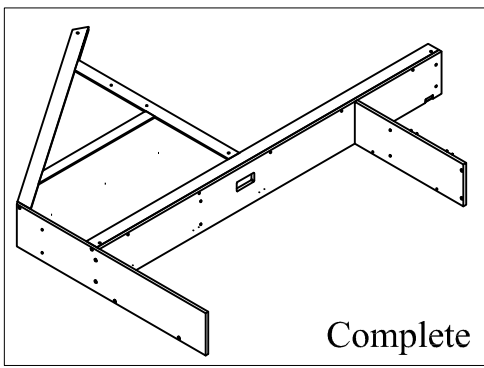

# STEP 10

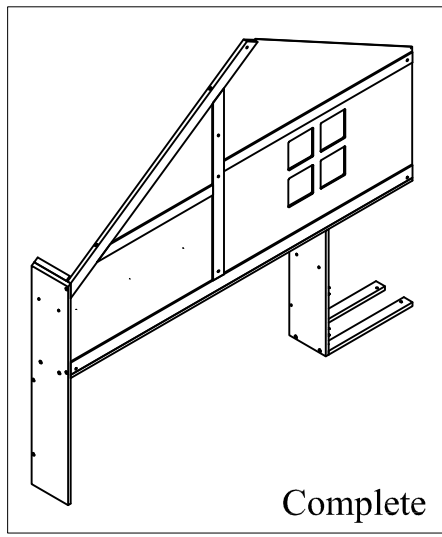

(A)		02
(D)		02
(I)		02

Stand step 9 upright and continue.

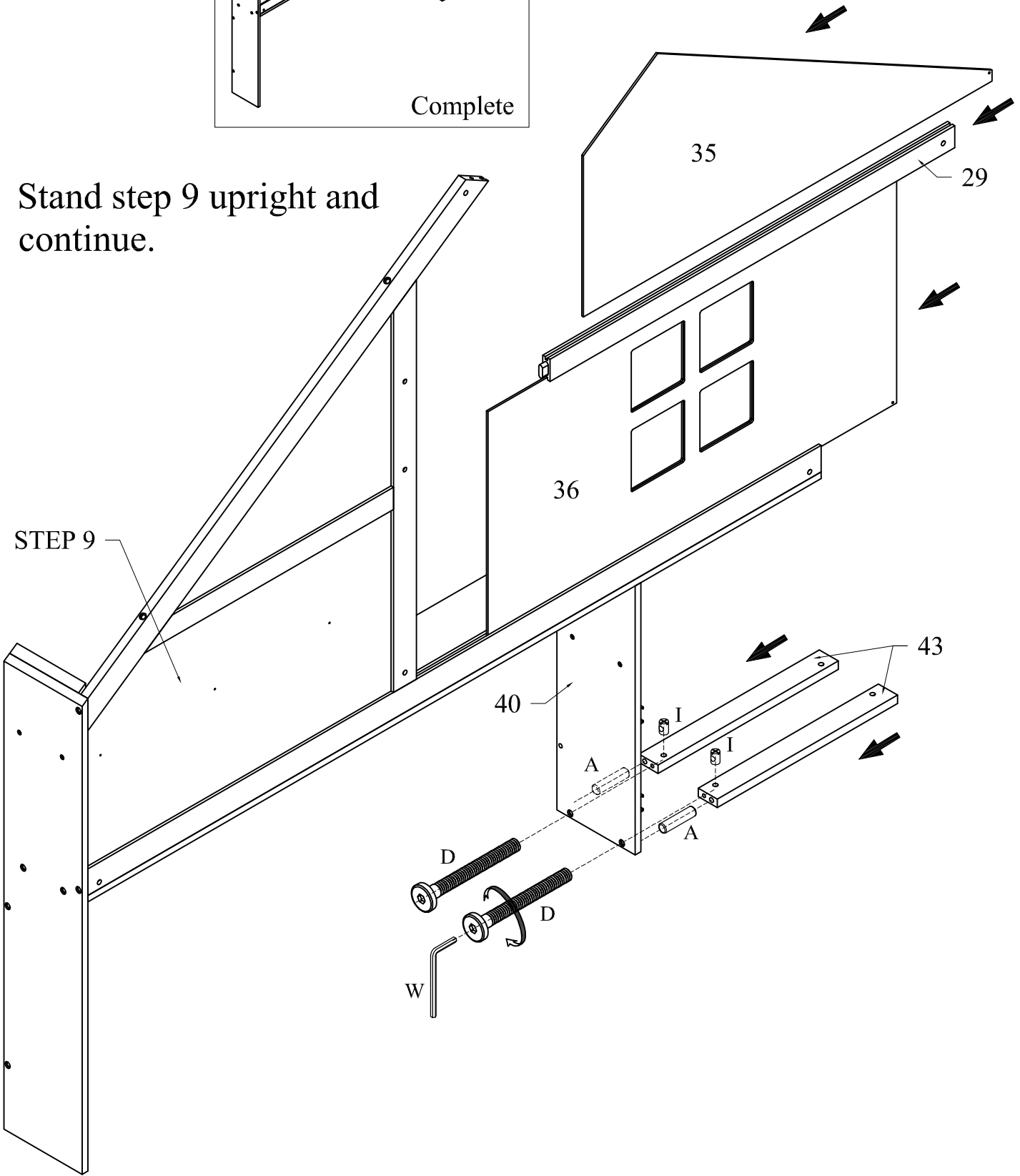

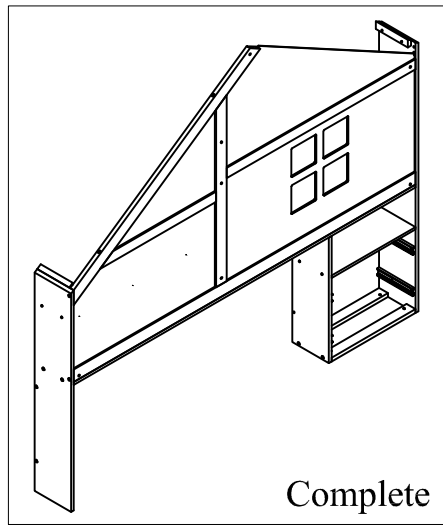

# STEP 11

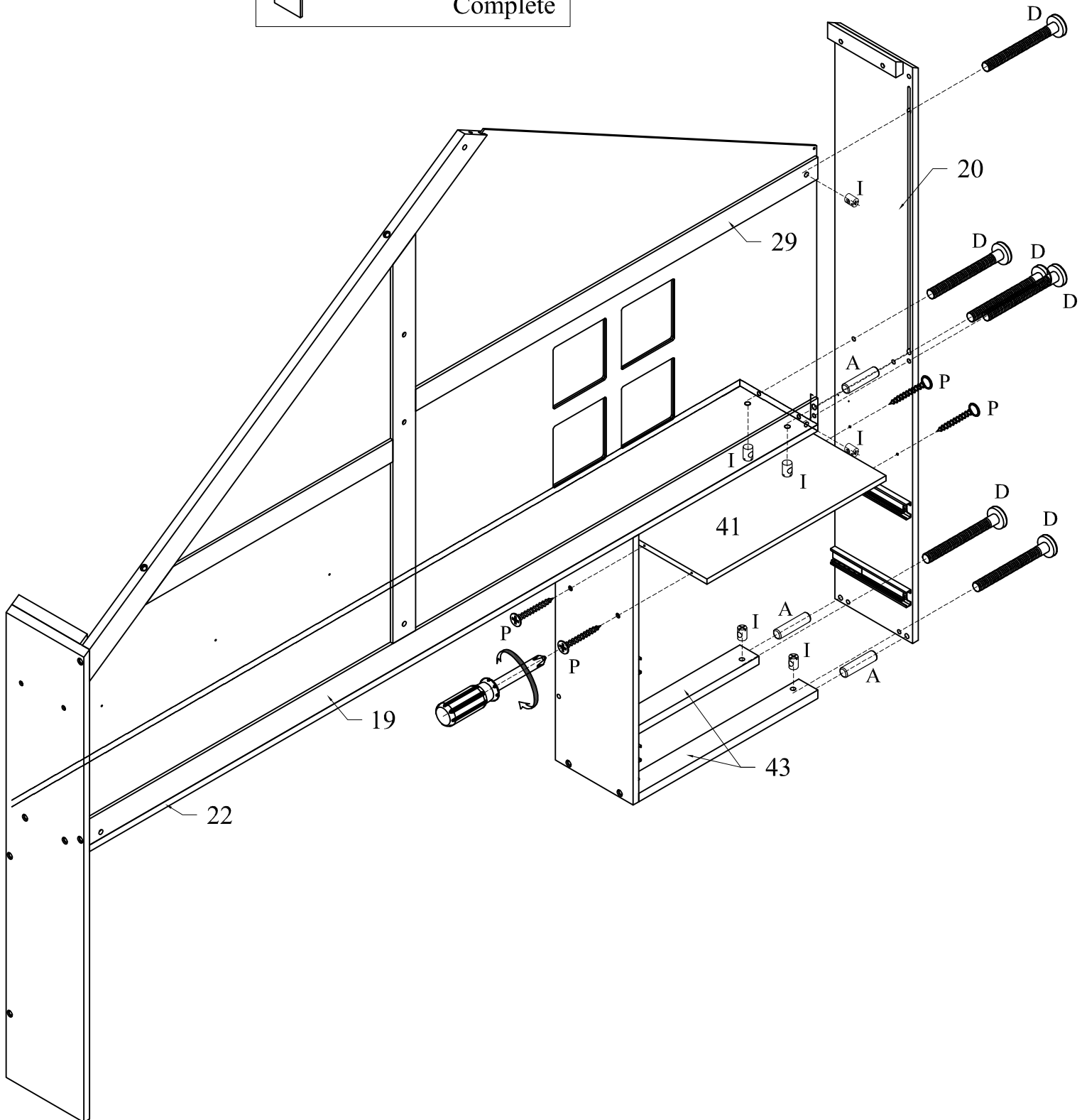

(A)		03
(D)		06
(P)		04
(I)		06



# STEP 12

(C)		01
(G)		01
(I)		01

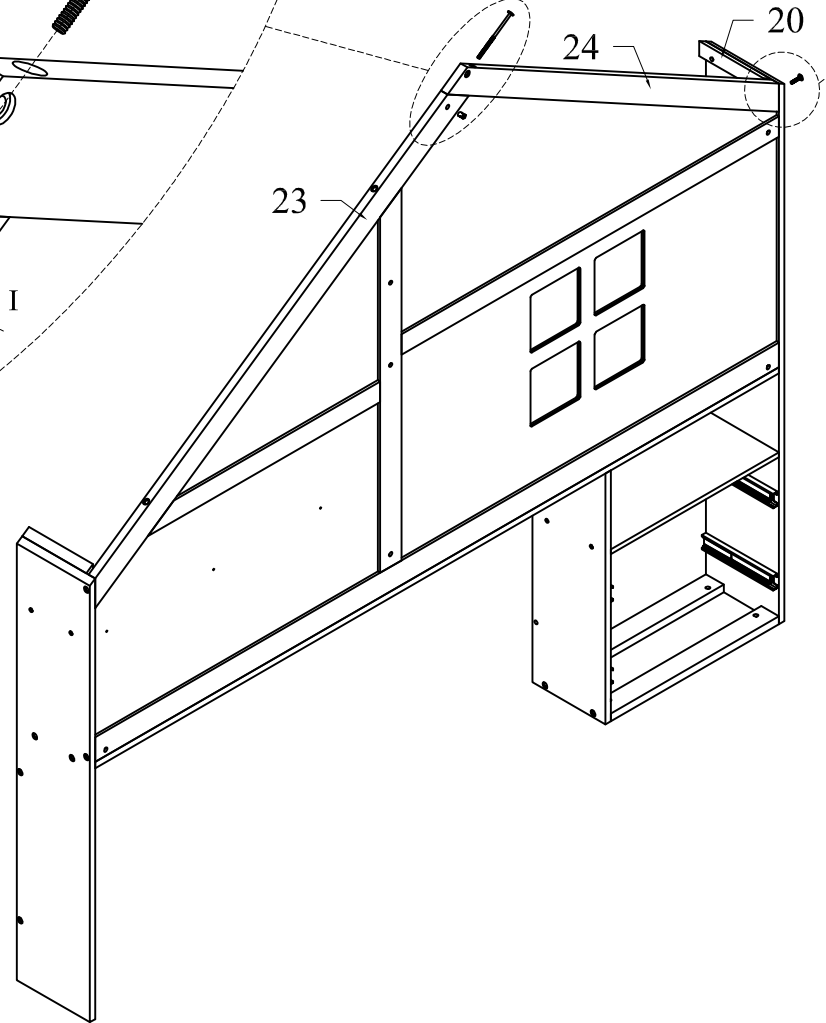
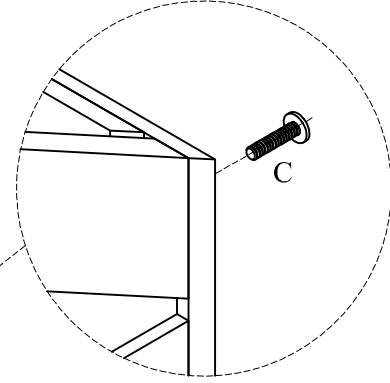
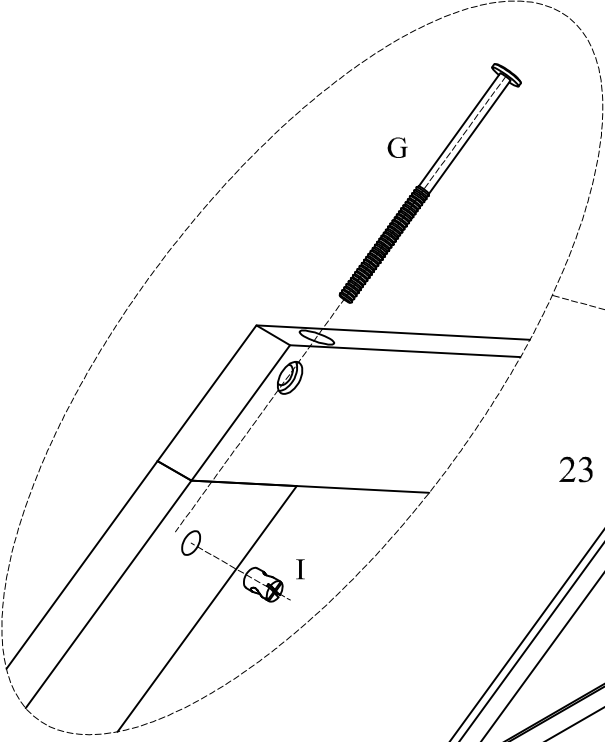
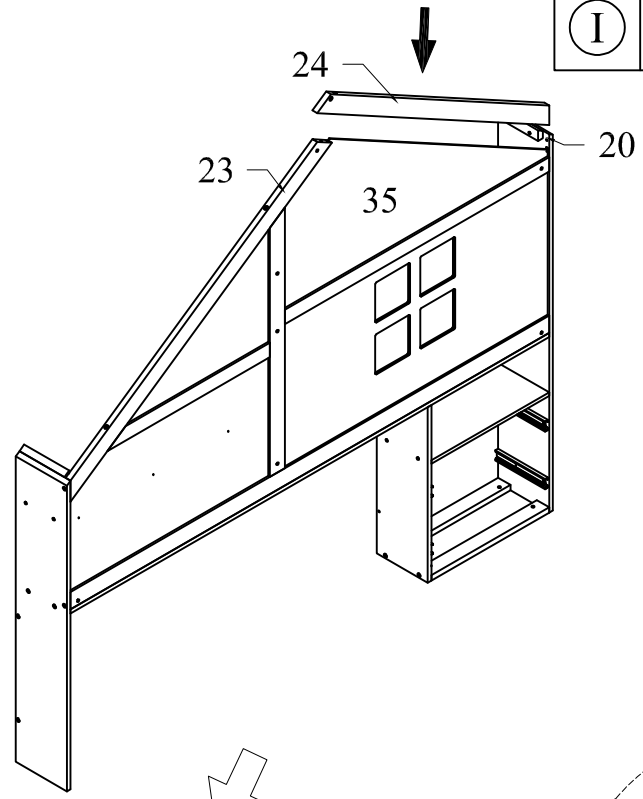
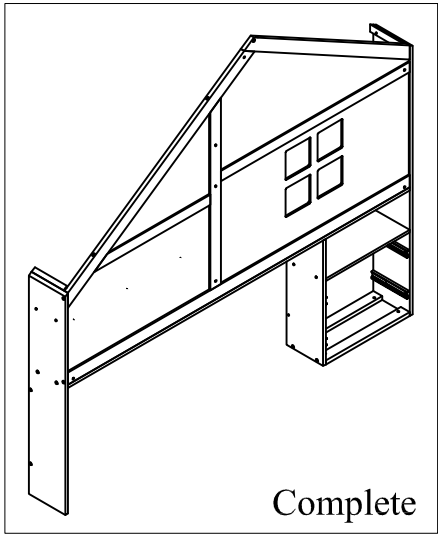

# STEP 13

C		01
---	--	----

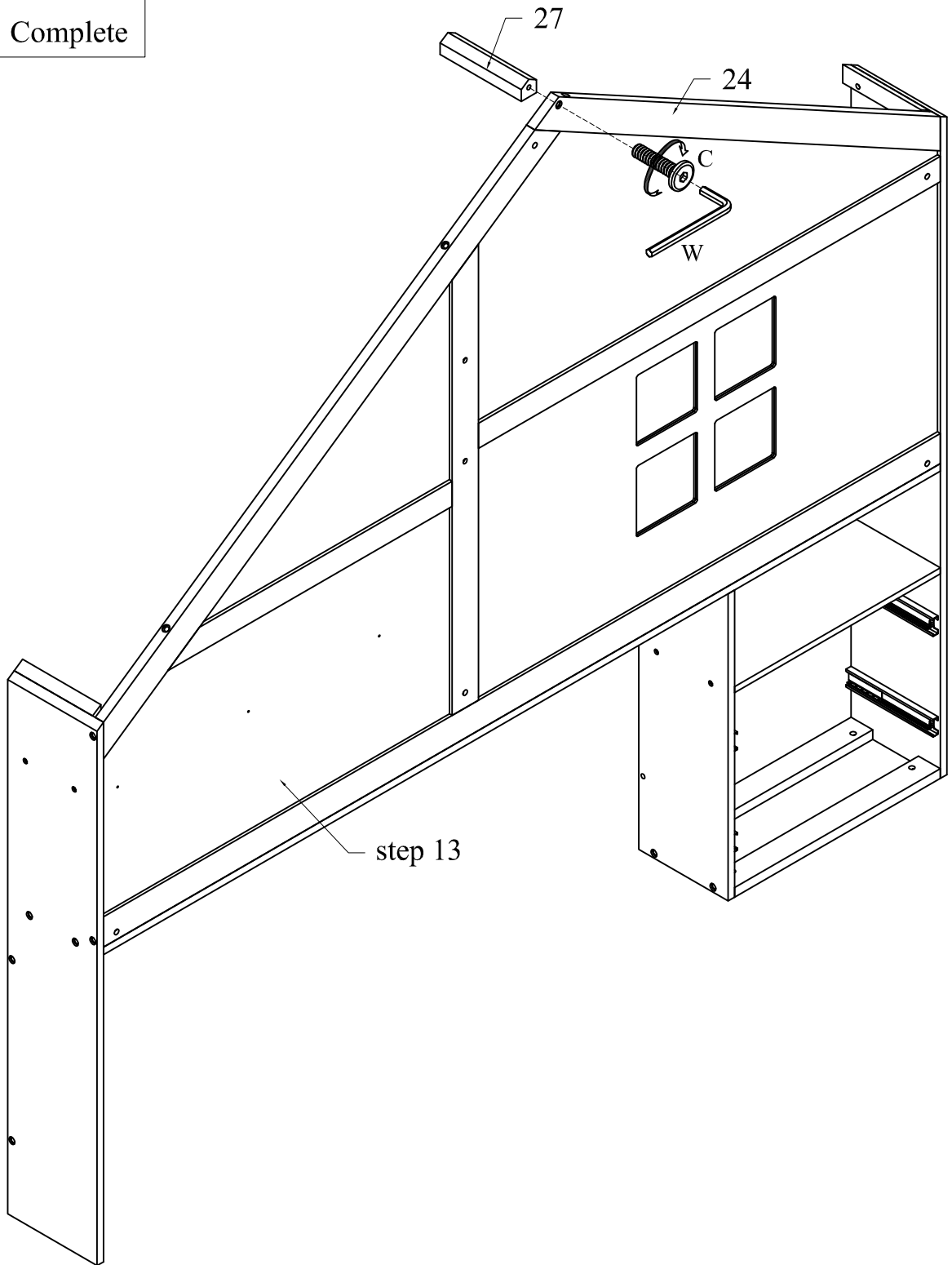
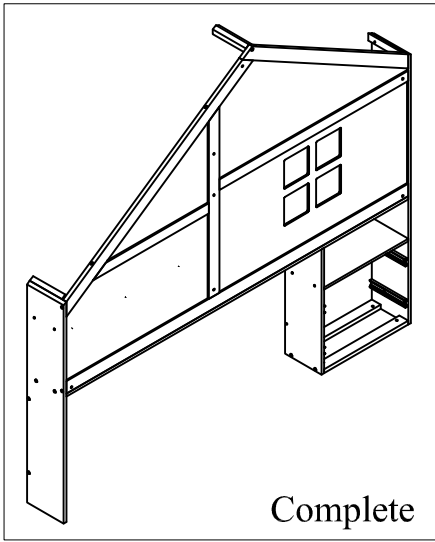

# STEP 14

(N)



14

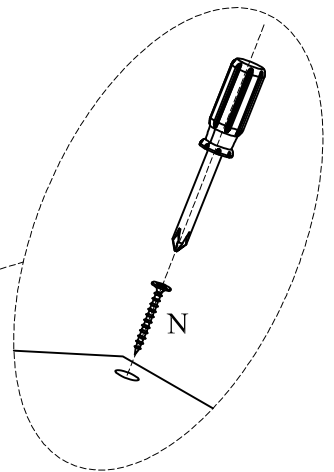
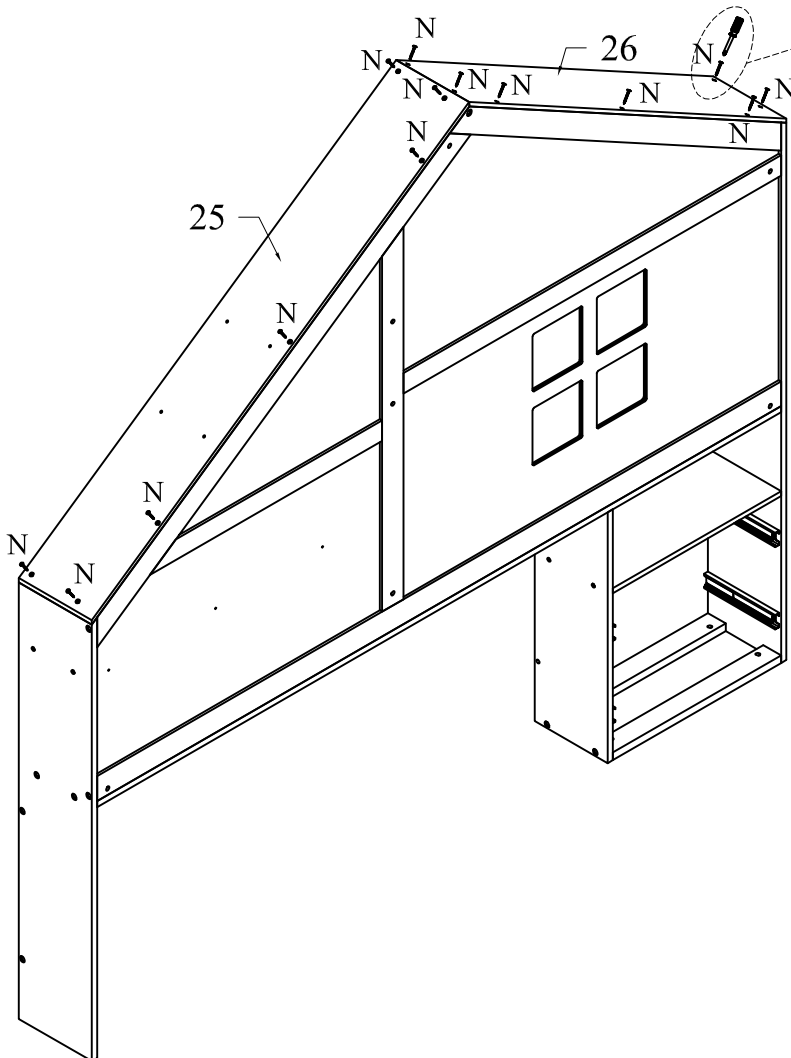
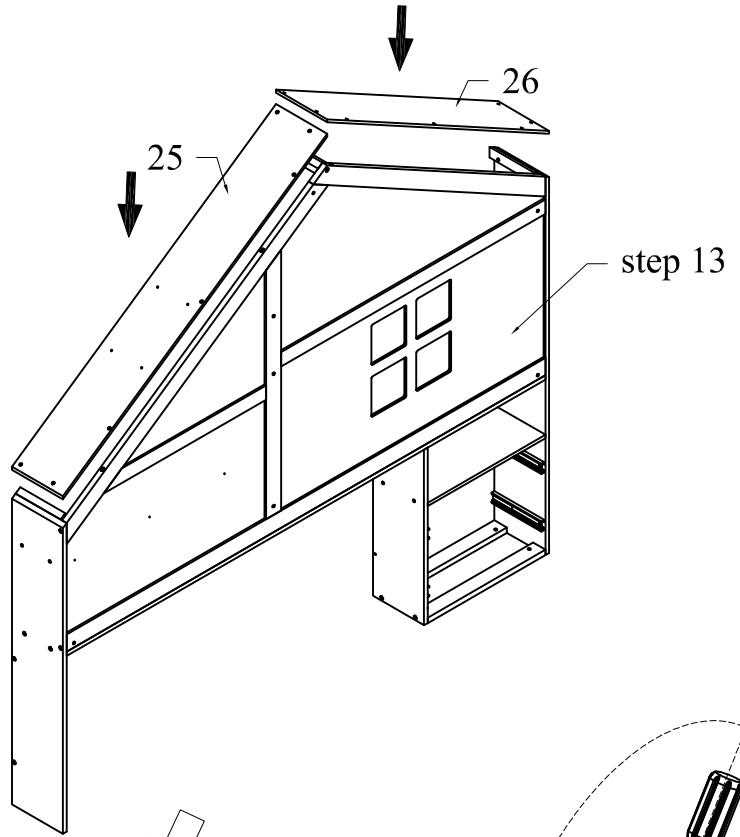
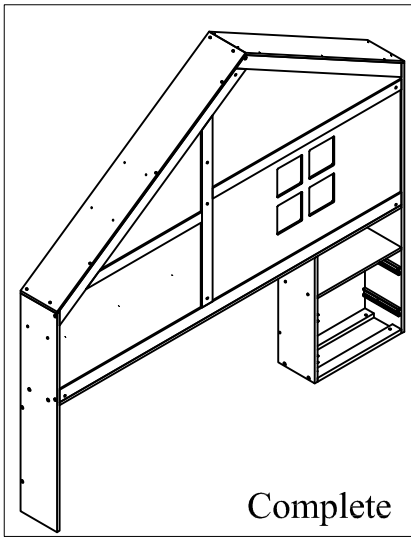

# STEP 15

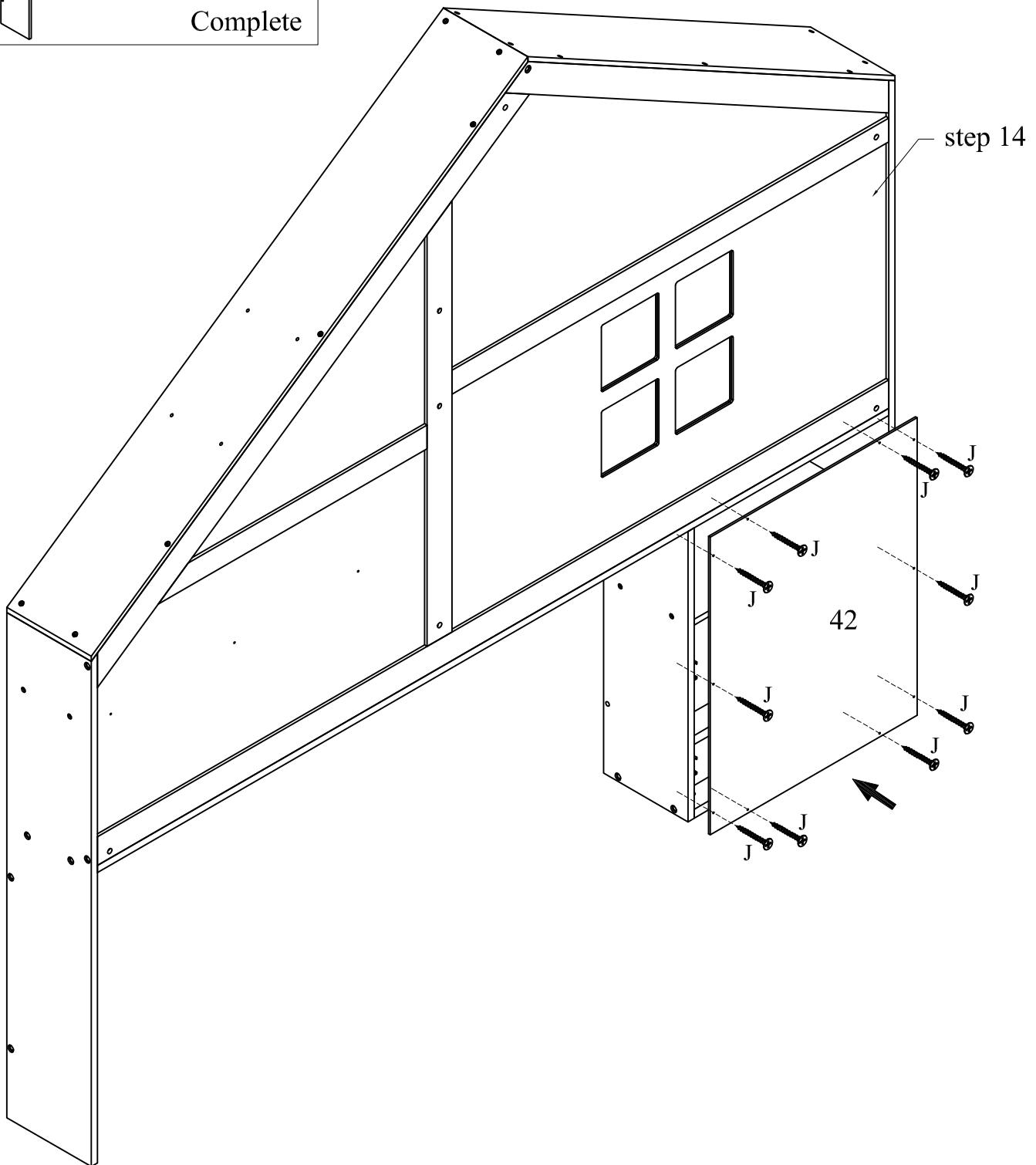
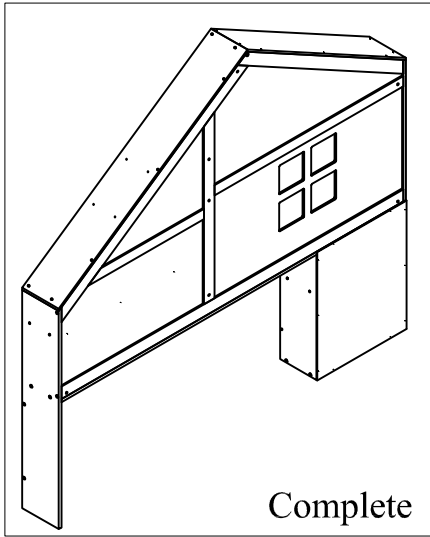

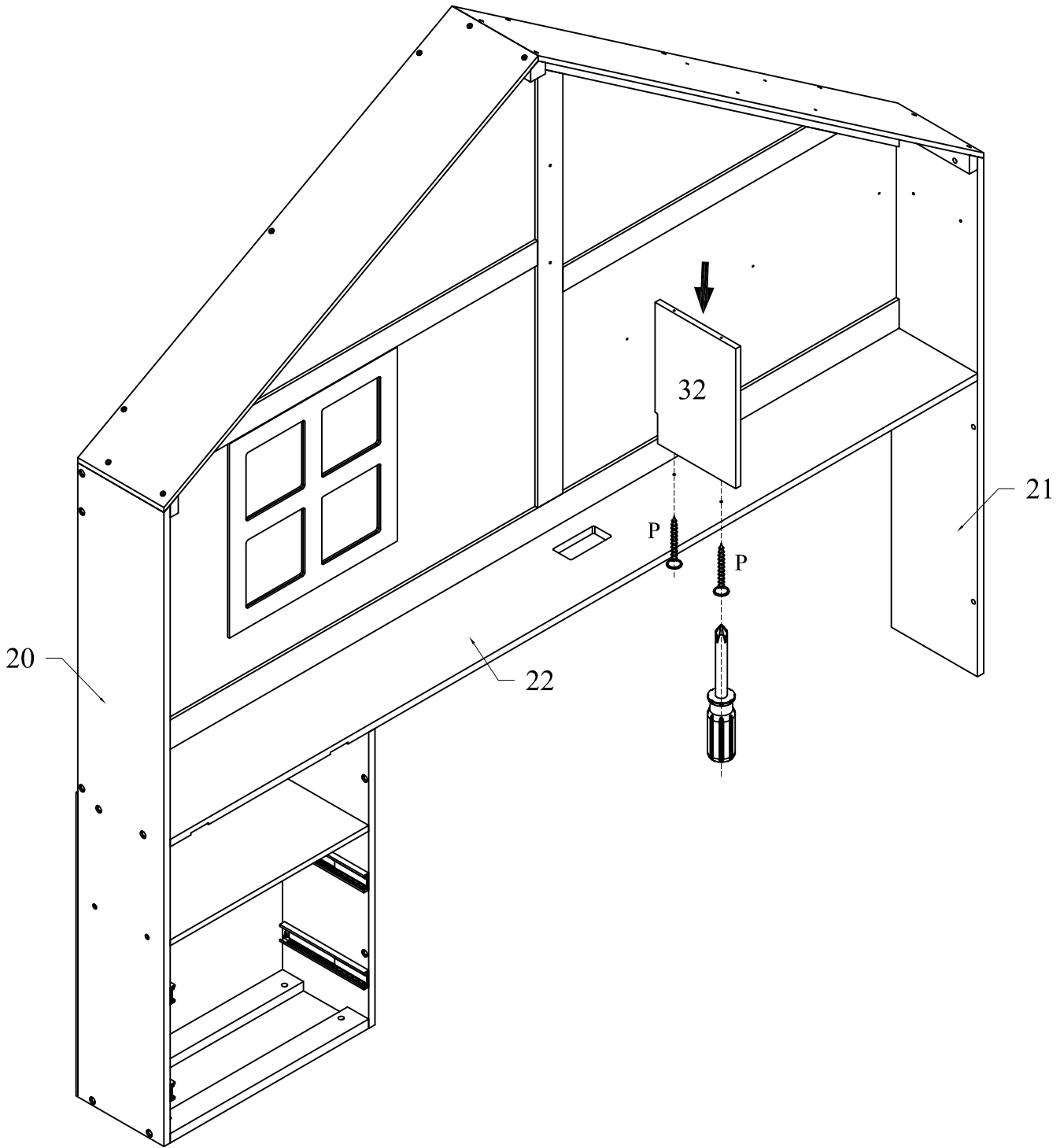

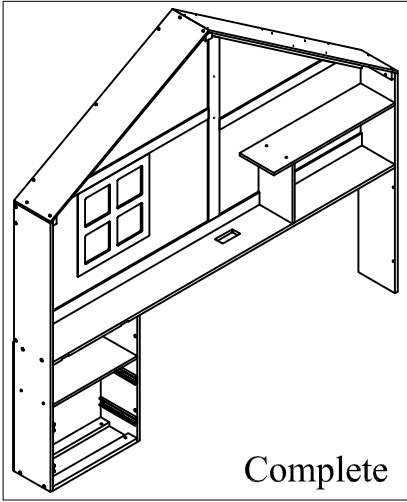

# STEP 17

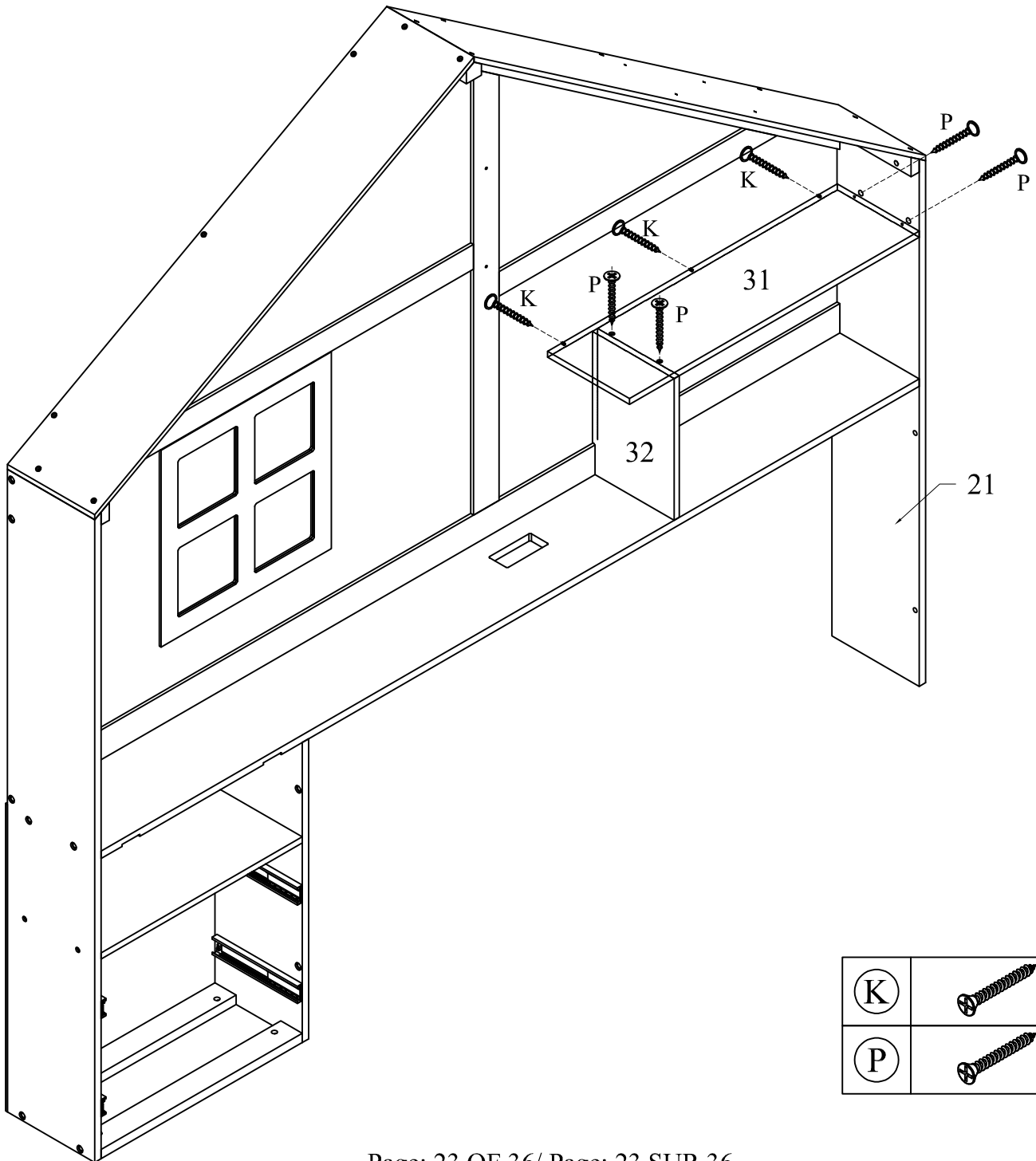
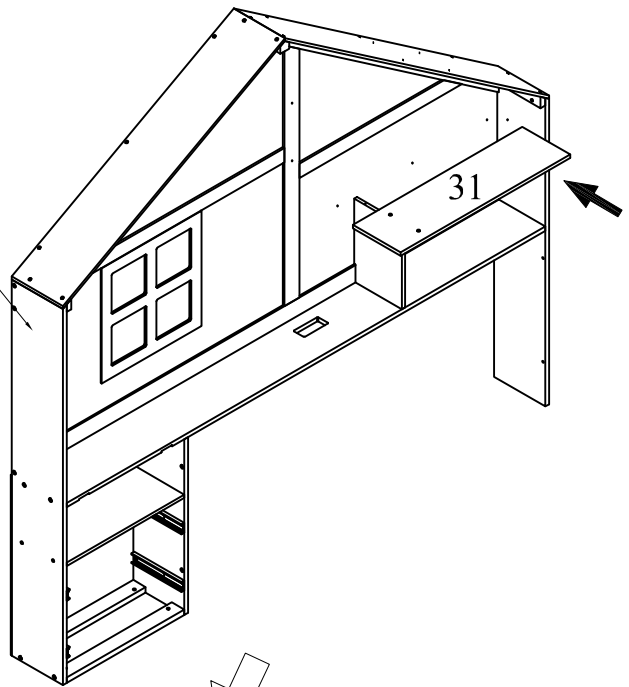

step 16



(K)		03
(P)		04

# STEP 18

C		04
---	--	----

step 17

step 5

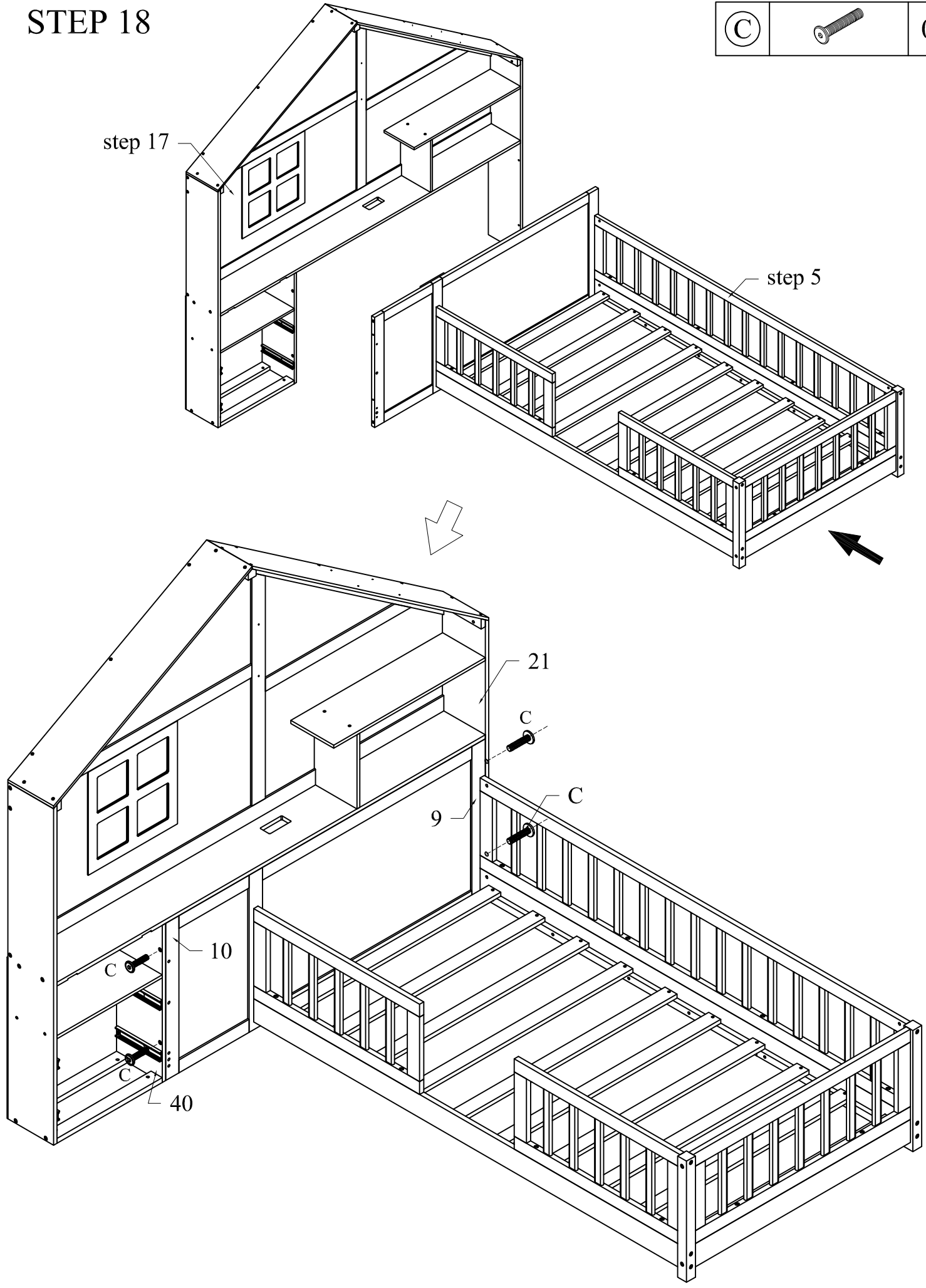

# STEP 19

S



04

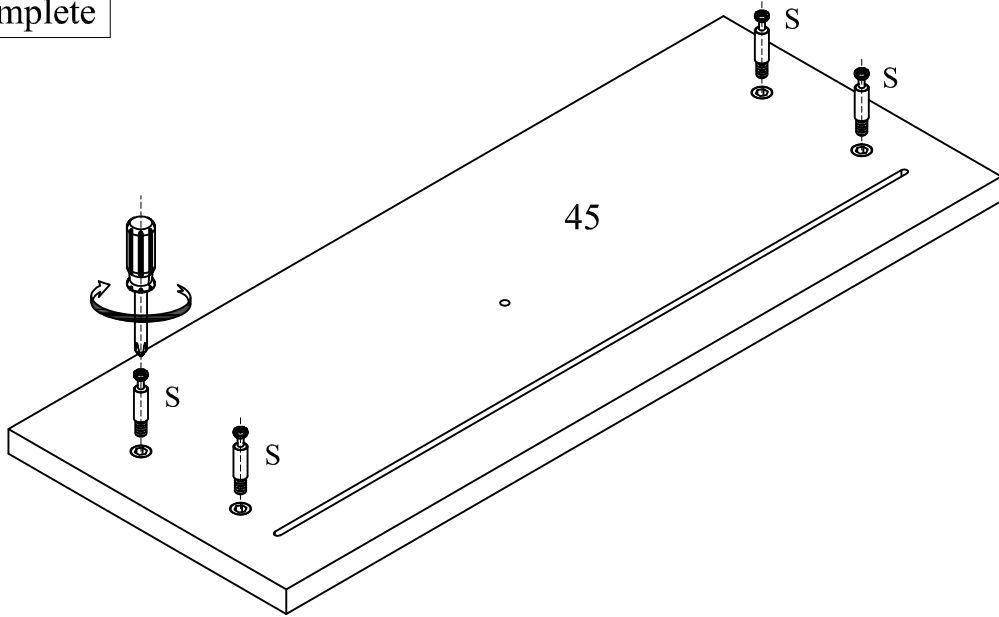
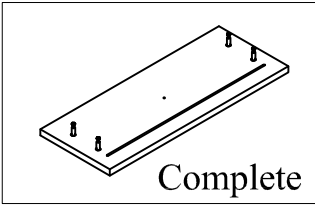

# STEP 20

S



04

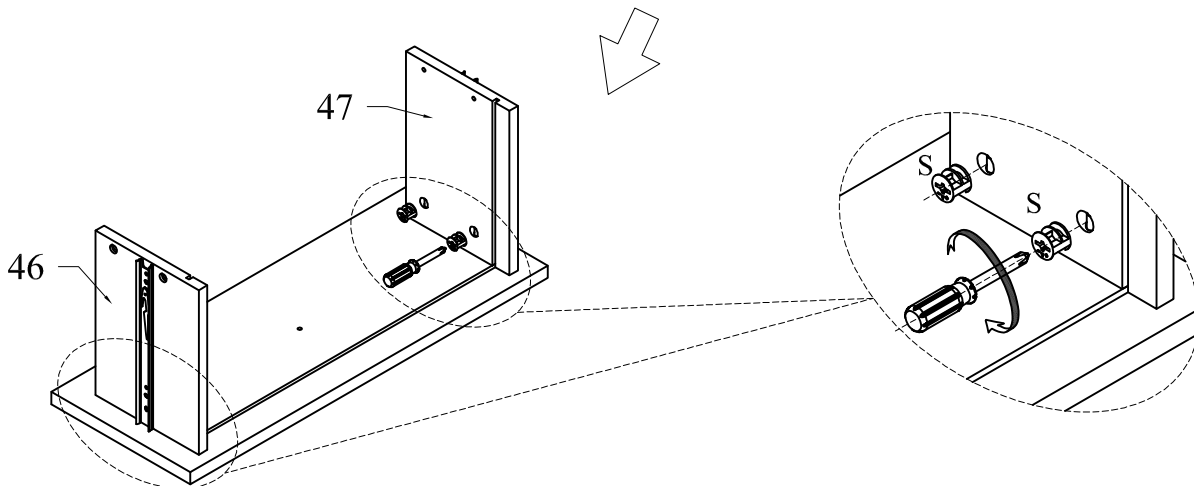
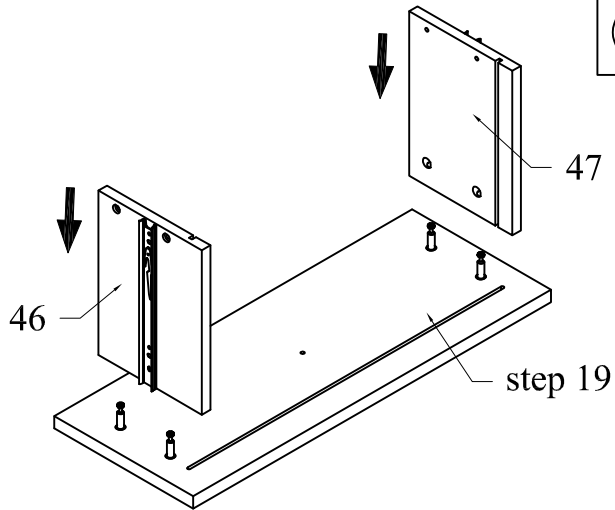
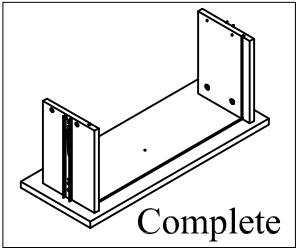

# STEP 21

P		04
---	--	----

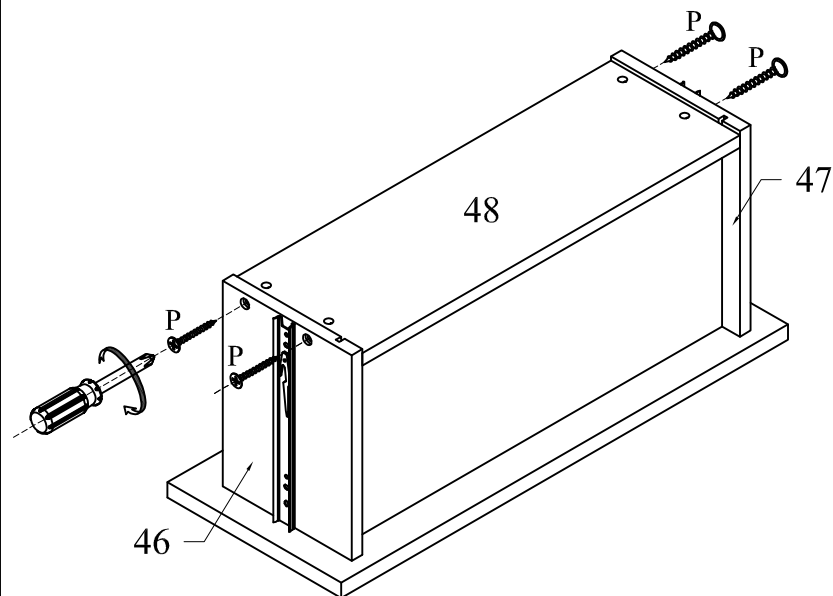
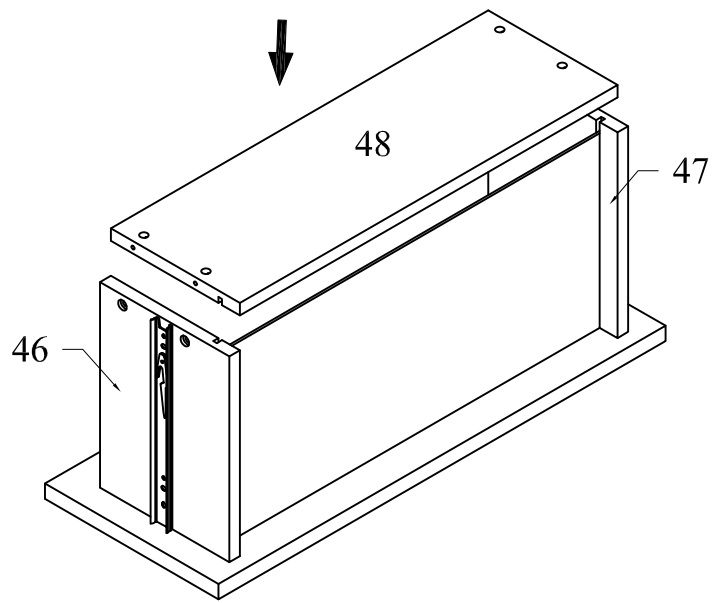
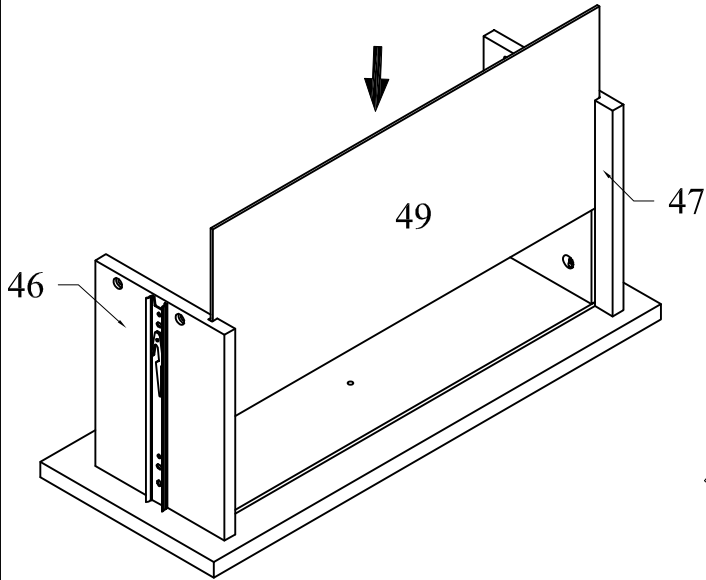
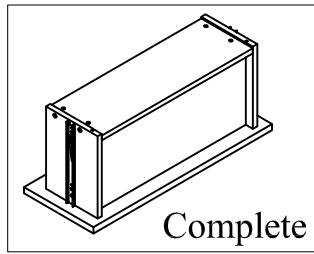

# STEP 22

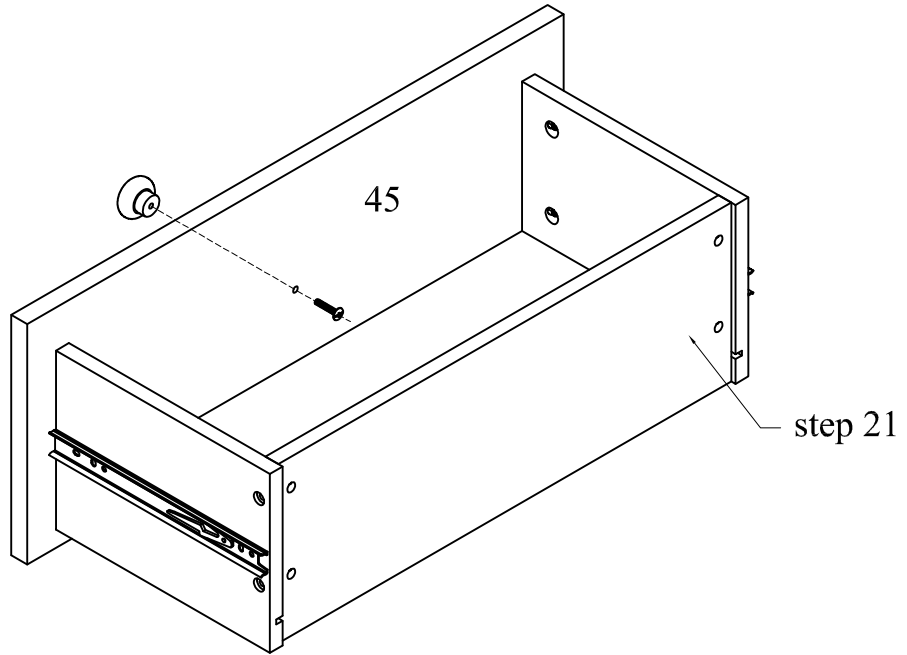
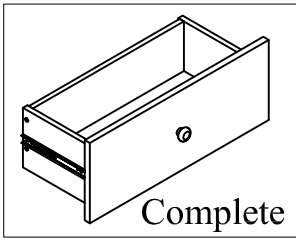

Reassemble steps 19 to 22 to create the second drawer.

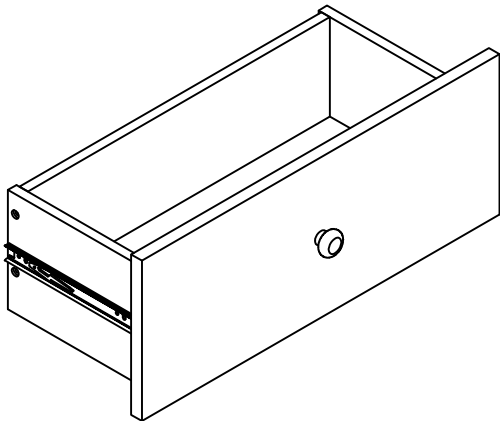

Drawer 1

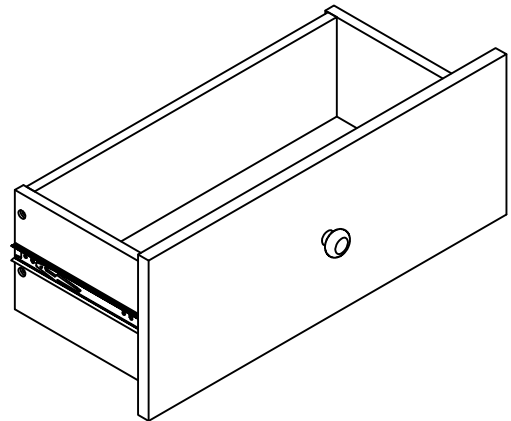

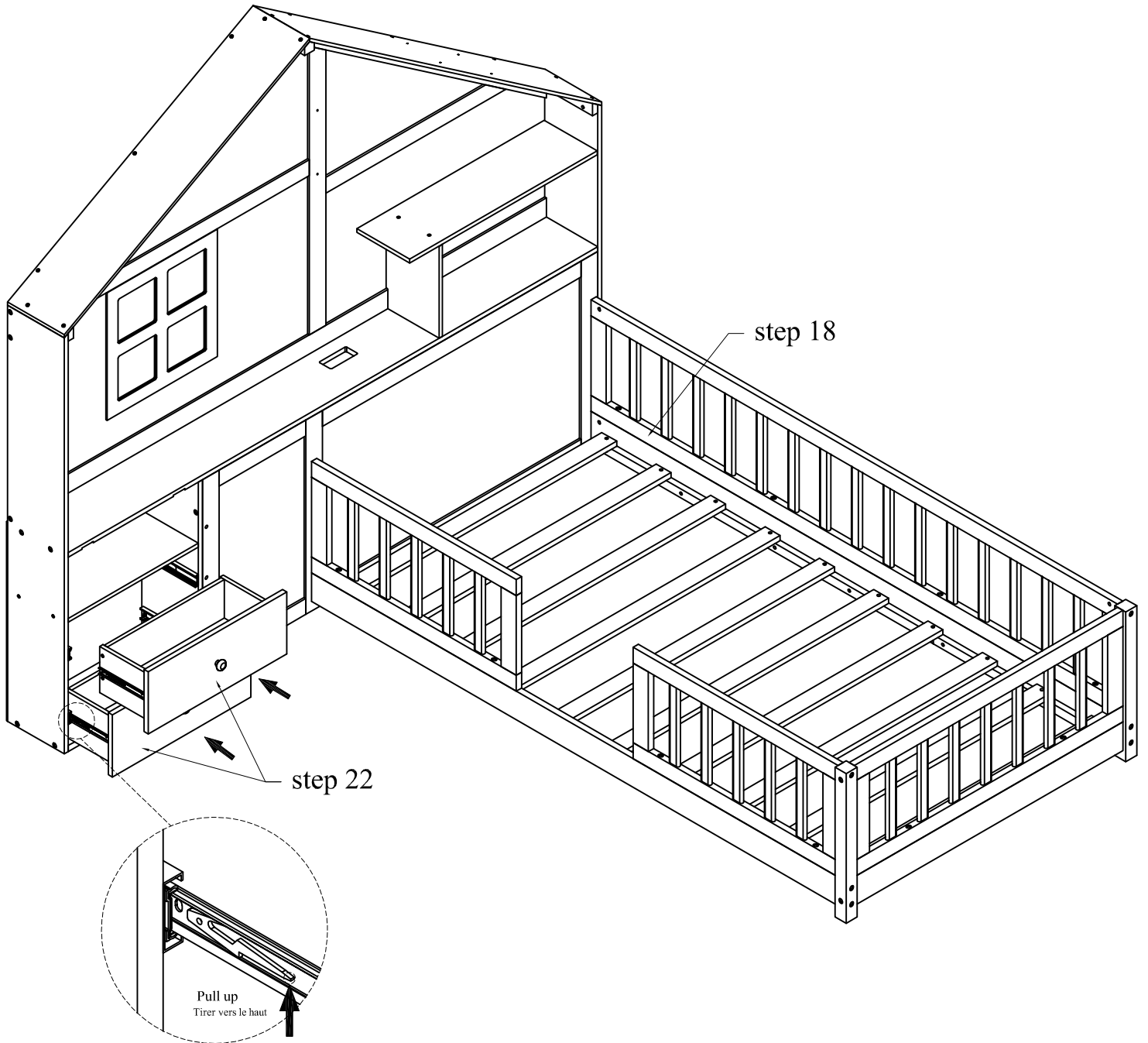
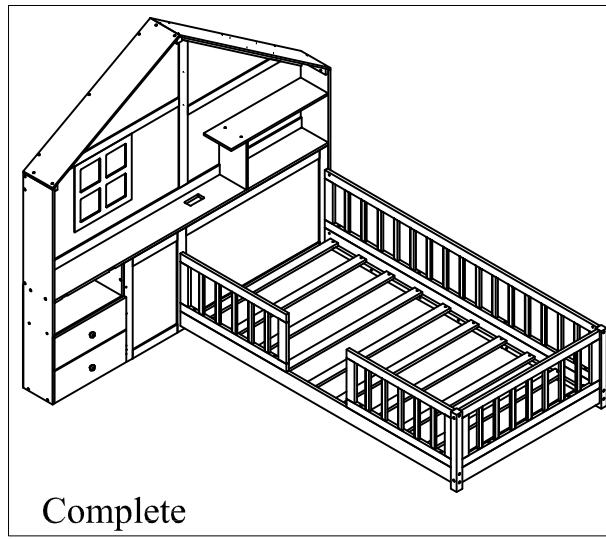

Drawer 2

# STEP 23



# STEP 24

(L)		04
(V)		02

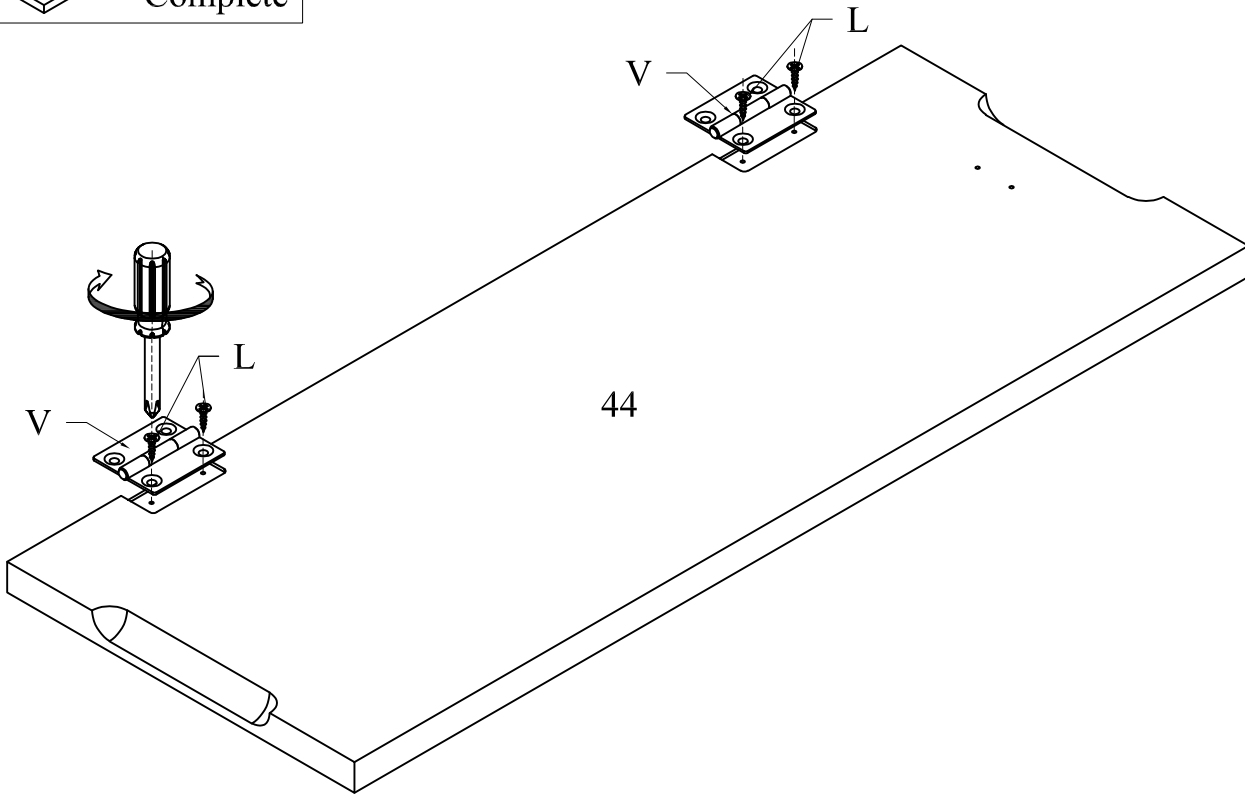
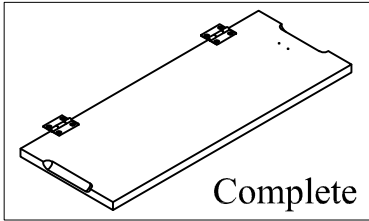

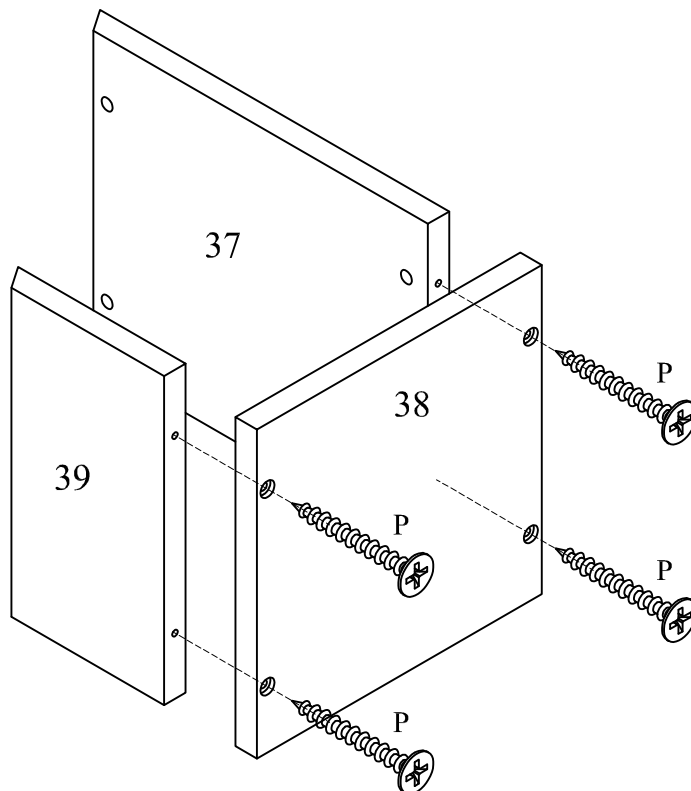
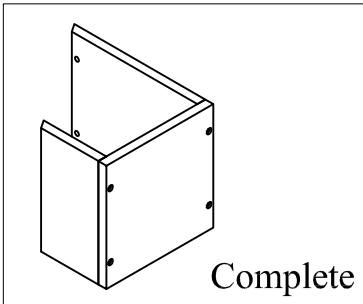

# STEP 25

(P)		04
-----	---	----

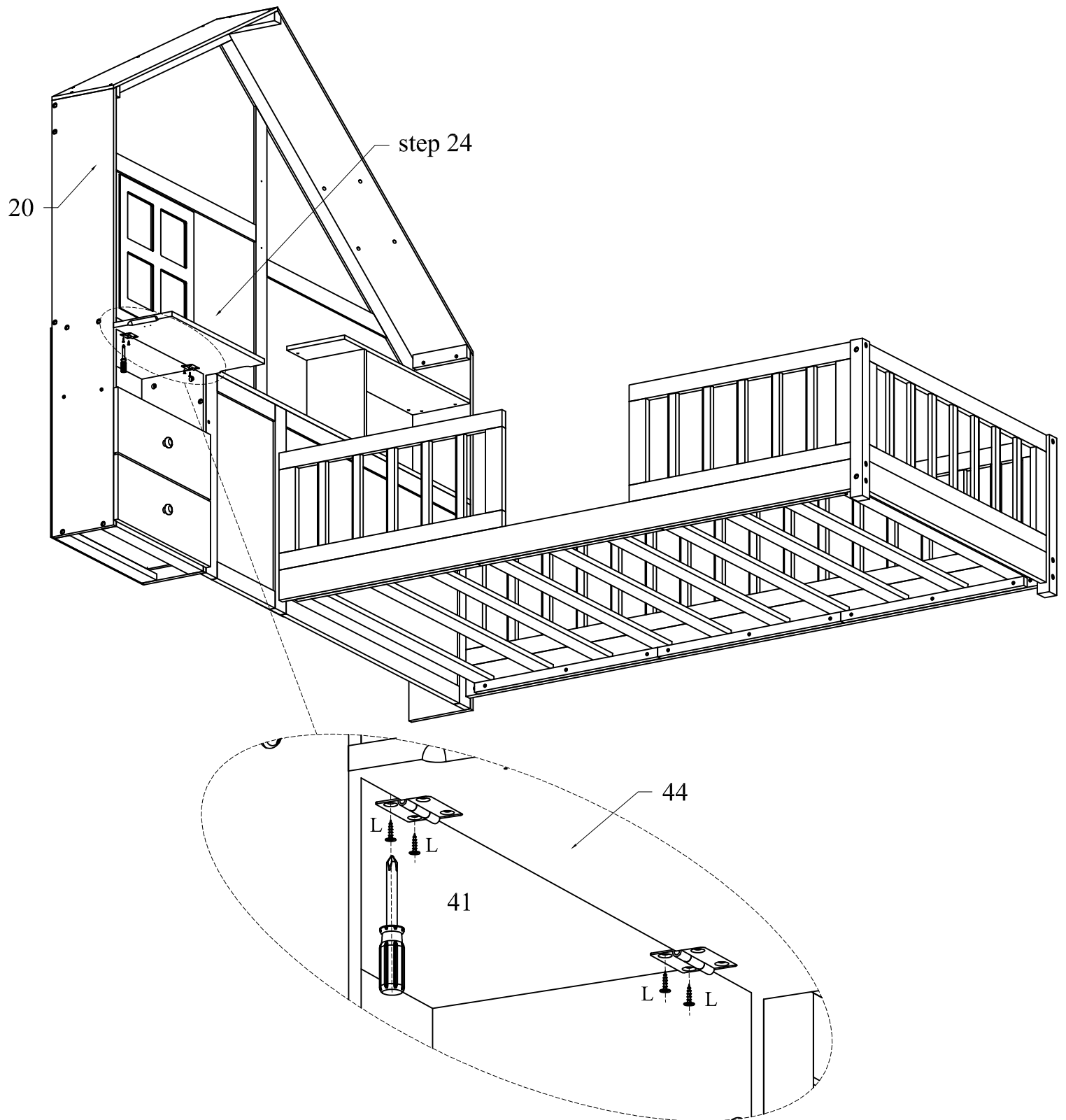



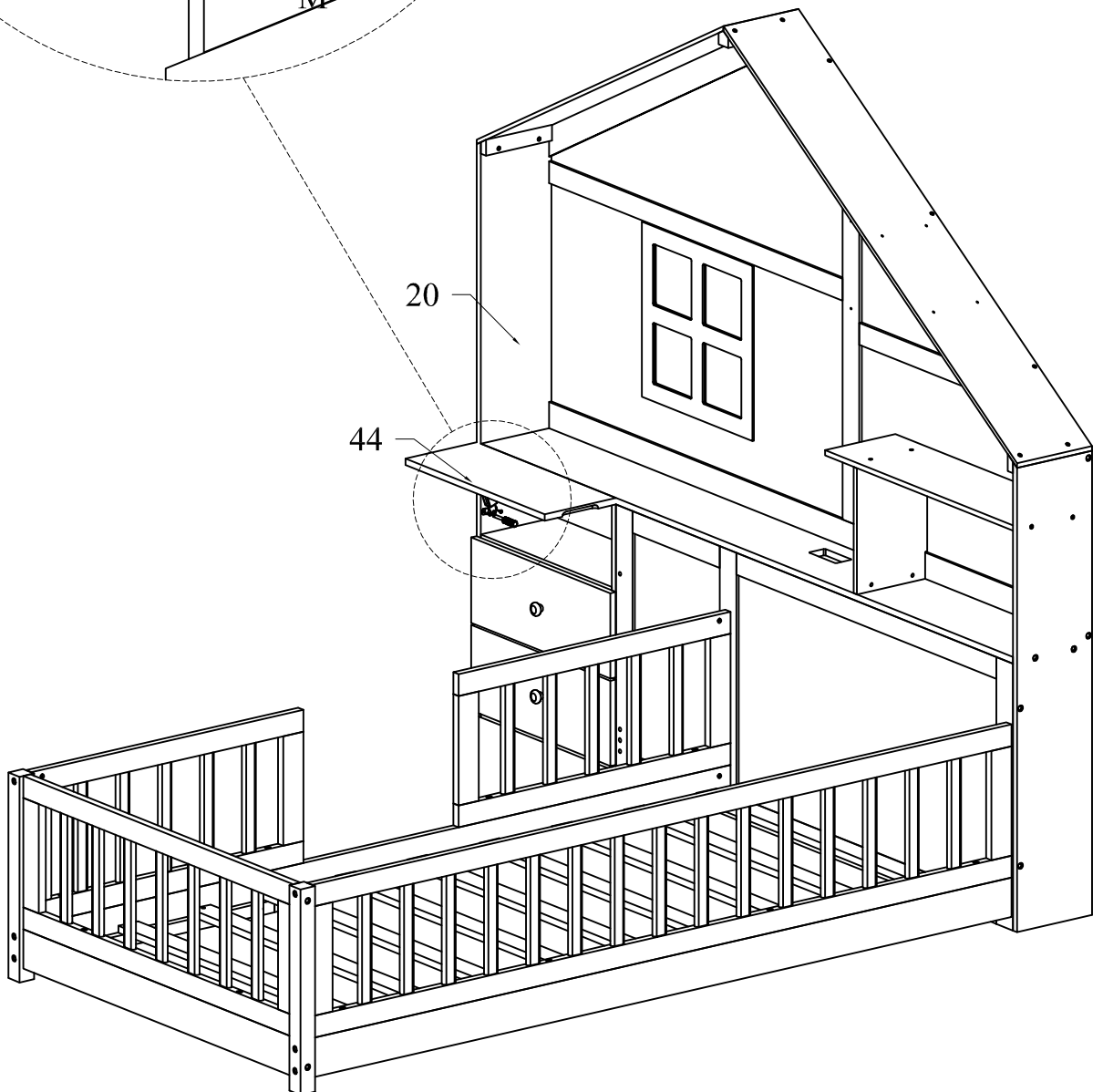
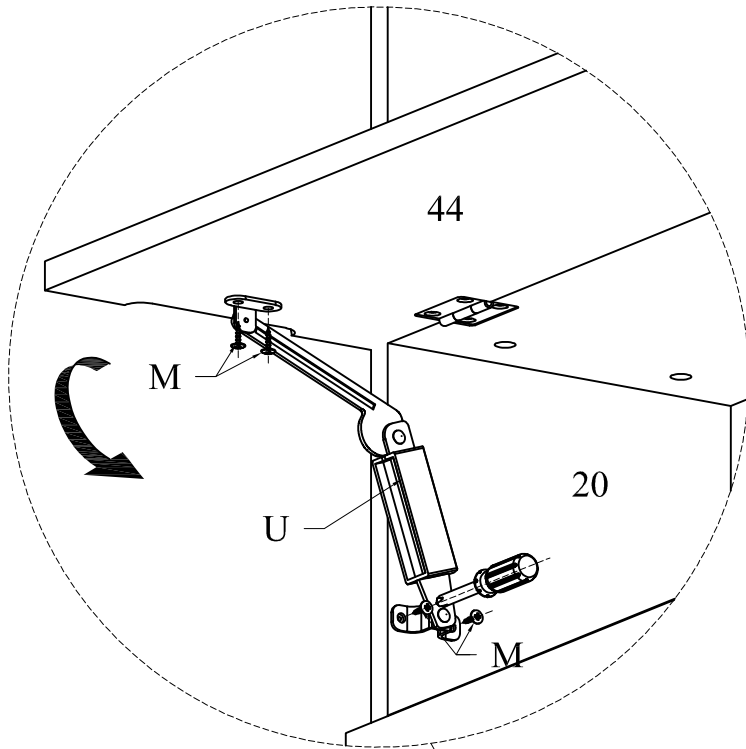

# STEP 27

(M)		04
(U)		01

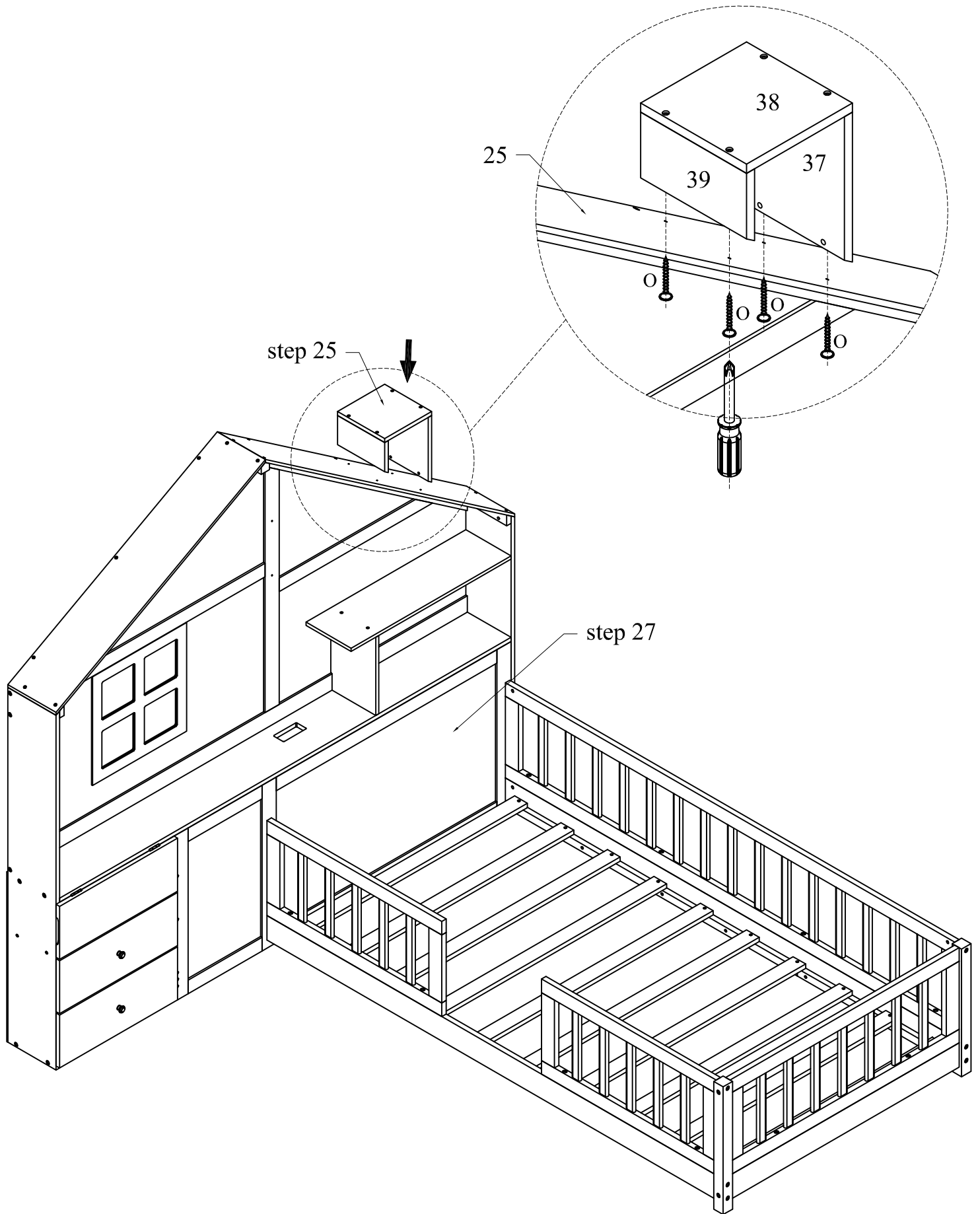



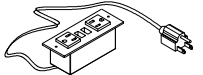

# STEP 29

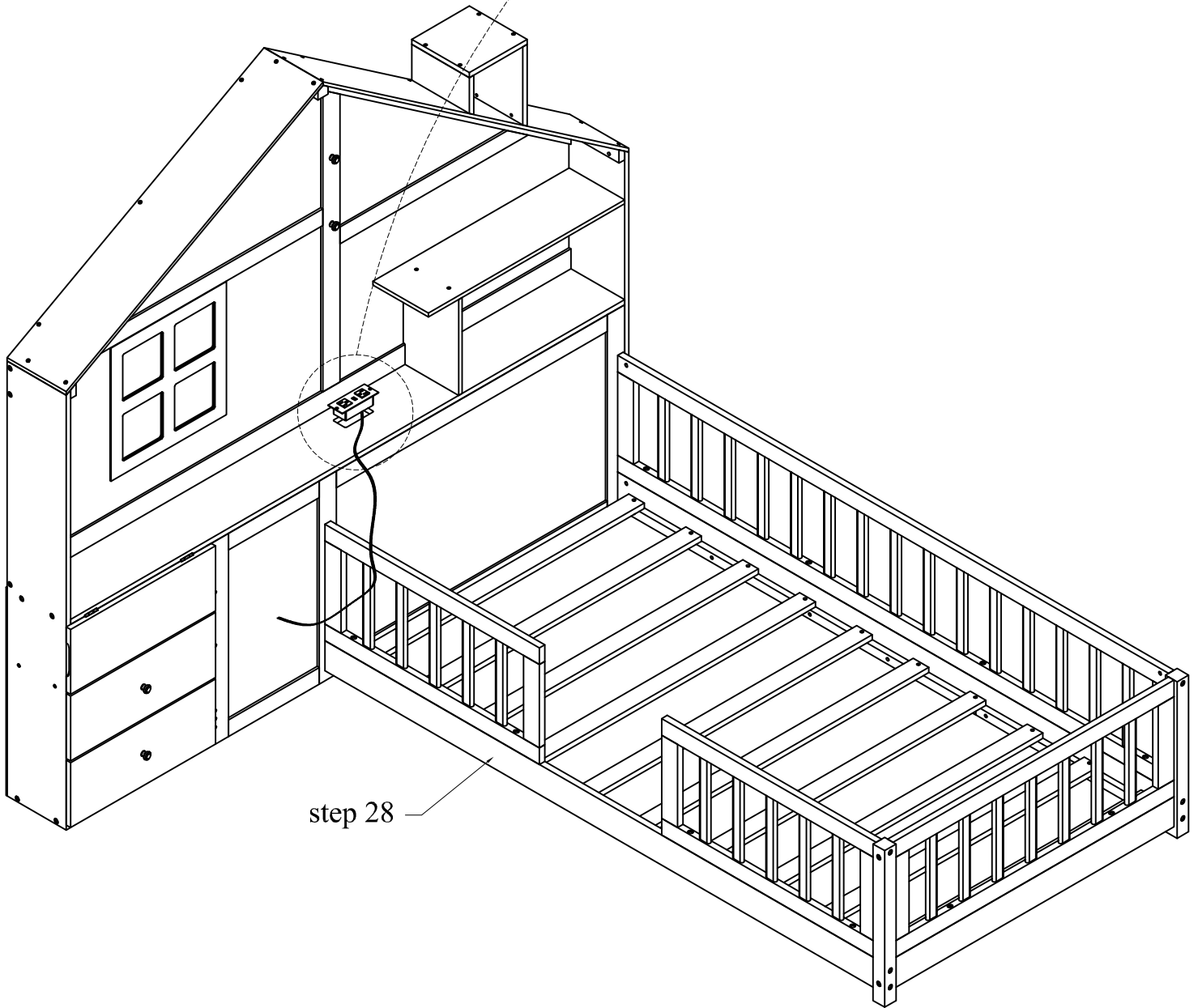
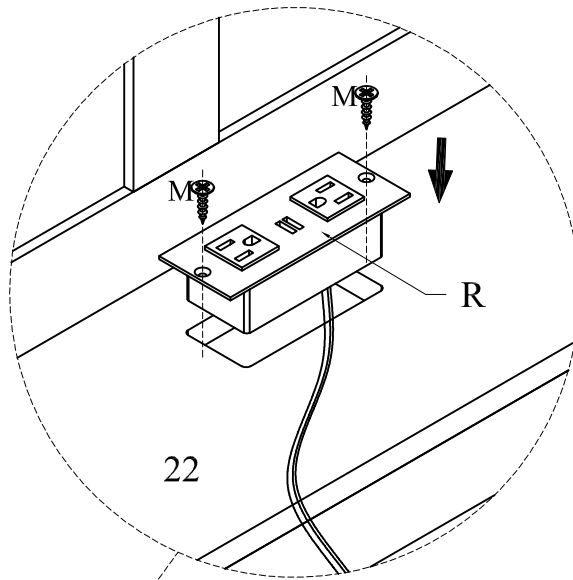
(R)		01
(M)		02

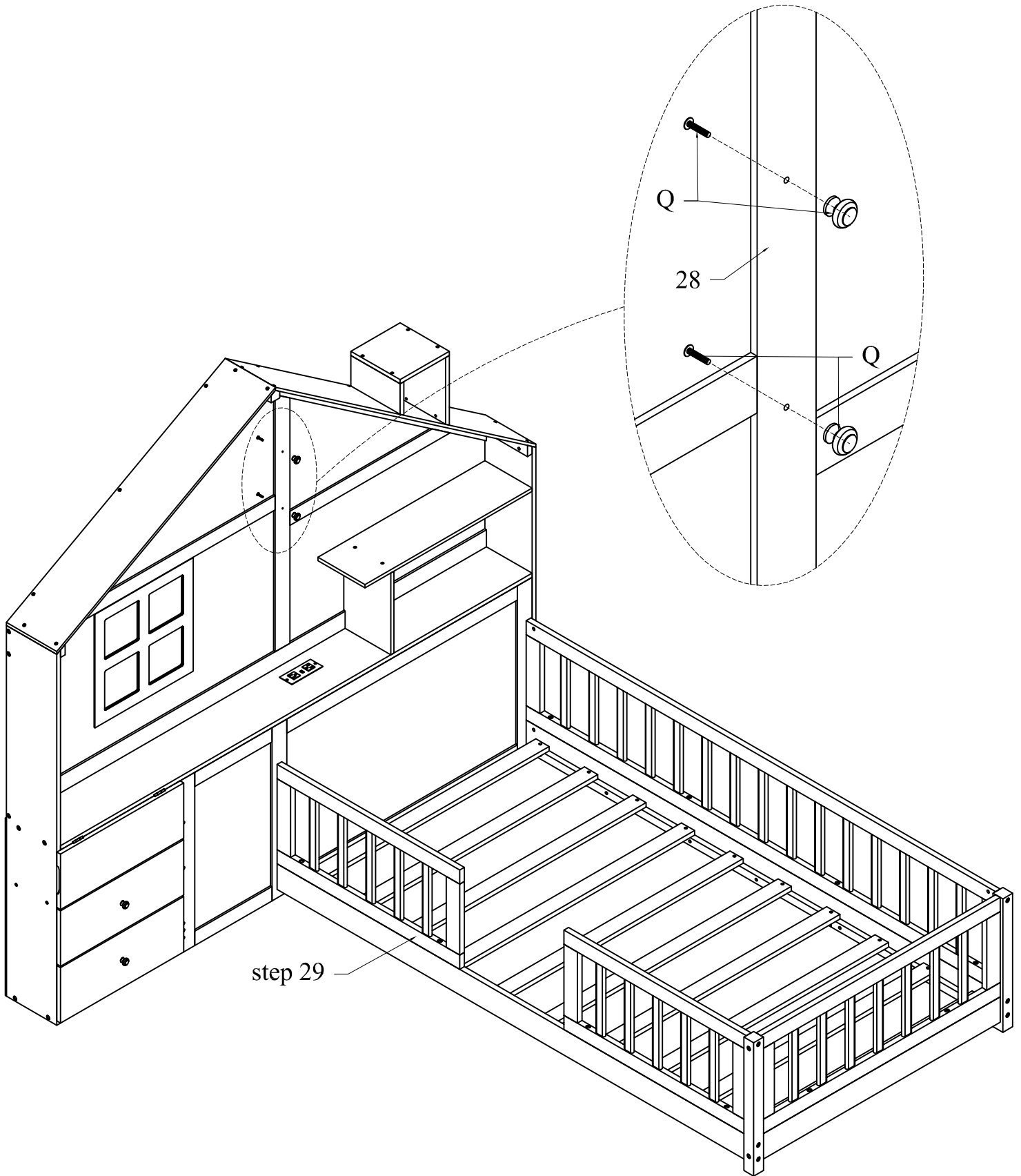



# STEP 31

(M)		12
(T)		03

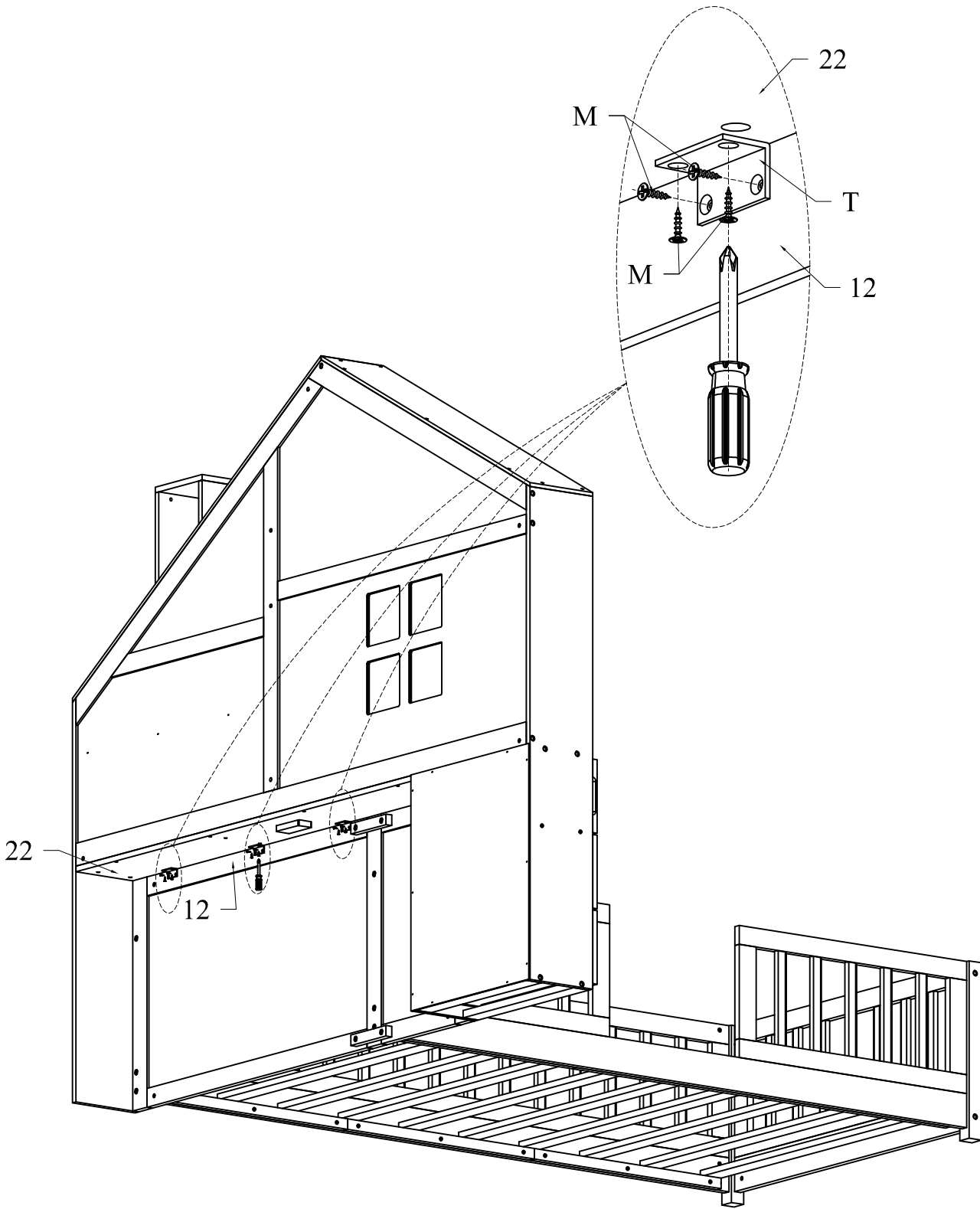

# COMPLETED

