

Shower Door  
5/16" glass (8mm)

## INSTALLATION GUIDE

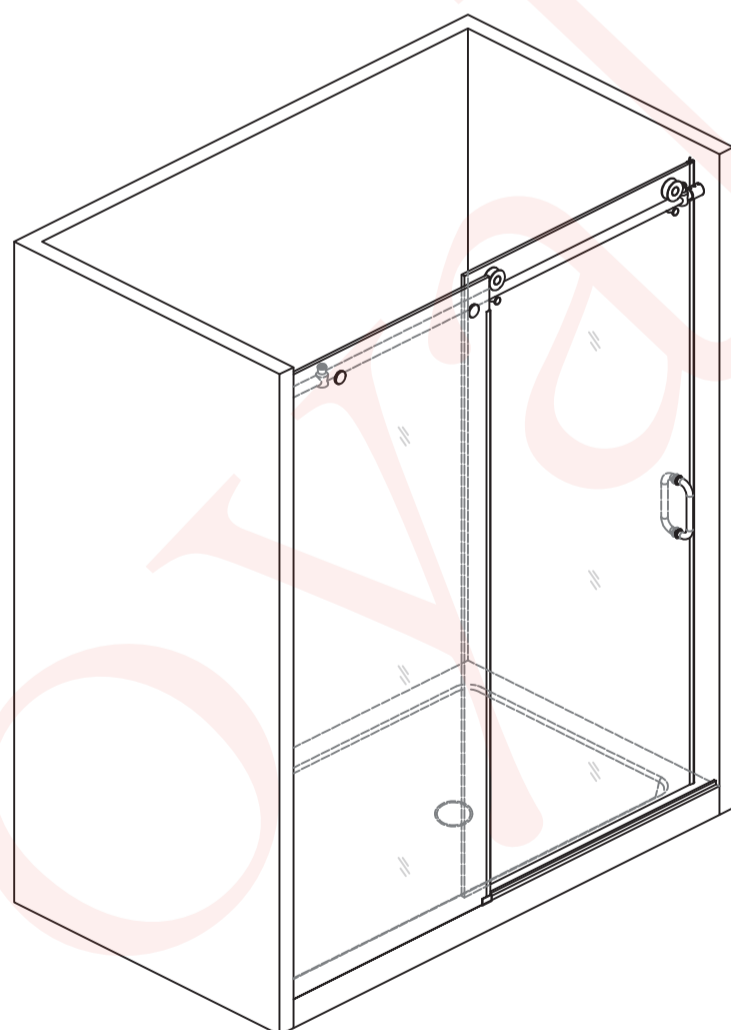
**CAUTION:** To reduce the risk of breakage, keep corner protectors on glass while installing. Keep corner protectors for use in case future adjustments are needed. Consult your local plumbing codes prior to installation.

Recommended Clearance Heights for Installation:  
74 inches (188 cm)

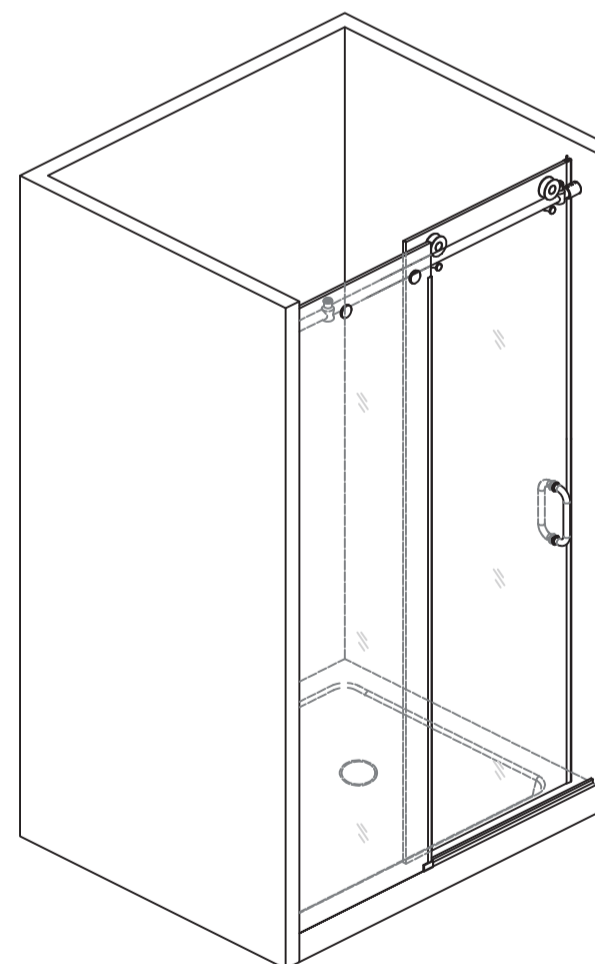
Recommended Width for Installation:  
48-inch enclosure:  
46 - 48 3/16inches (116.8 - 122.4 cm)

60-inch enclosure:  
58 - 60 3/16inches (147.3- 152.9 cm)

MODEL:  
02246074MB08N  
02246074CH08N



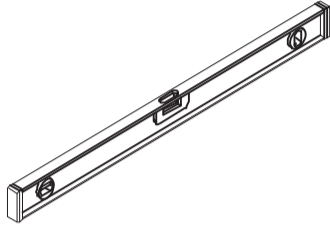
60X74-inch Enclosure



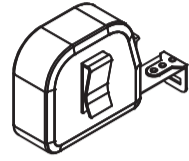
48X74-inch Enclosure

## TOOLS REQUIRED

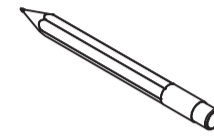
Level



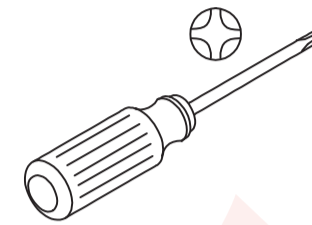
Measuring Tape



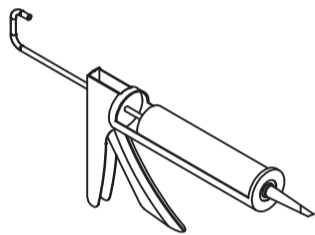
Pencil



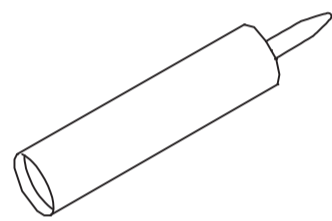
Phillips screw driver



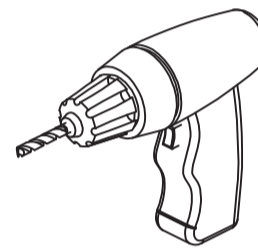
Silicone



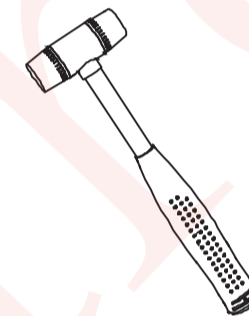
Sealant



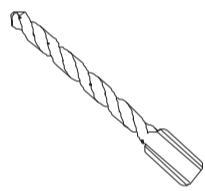
Power drill



Soft Head Hammer



Drill Bits



☒=1/8"(3mm)&☒=1/4"(6mm)&  
☒=5/16"(8mm)&☒=3/8"(10mm)

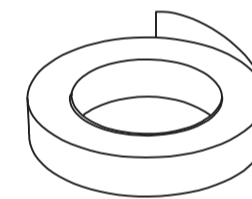
Glove



MASONRY DRILL BIT FOR TILE  
Ø6mm



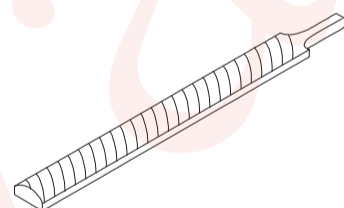
Masking or painter's tape



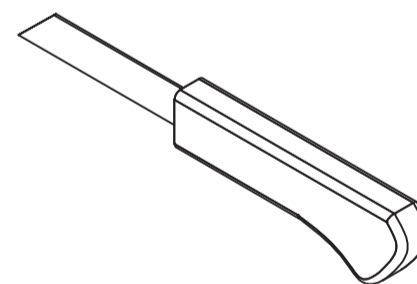
Safety Glasses



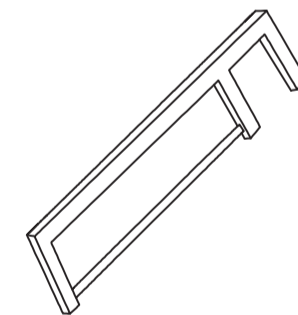
Metal File



Razor Knife



Hack Saw



**CAUTION:** When cutting or drilling metal components or when handling glass, to reduce the risk of personal injury, protective eye wear, gloves, and closed-toe shoes are required.

## SAFETY INFORMATION

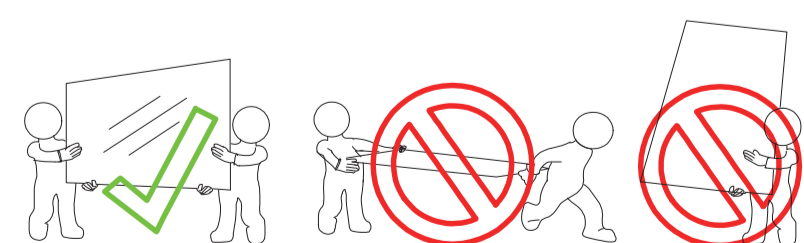
### CAUTION

Please carefully read the following important safety information before handling or installing this shower. There is a risk of serious injury while handling this product.

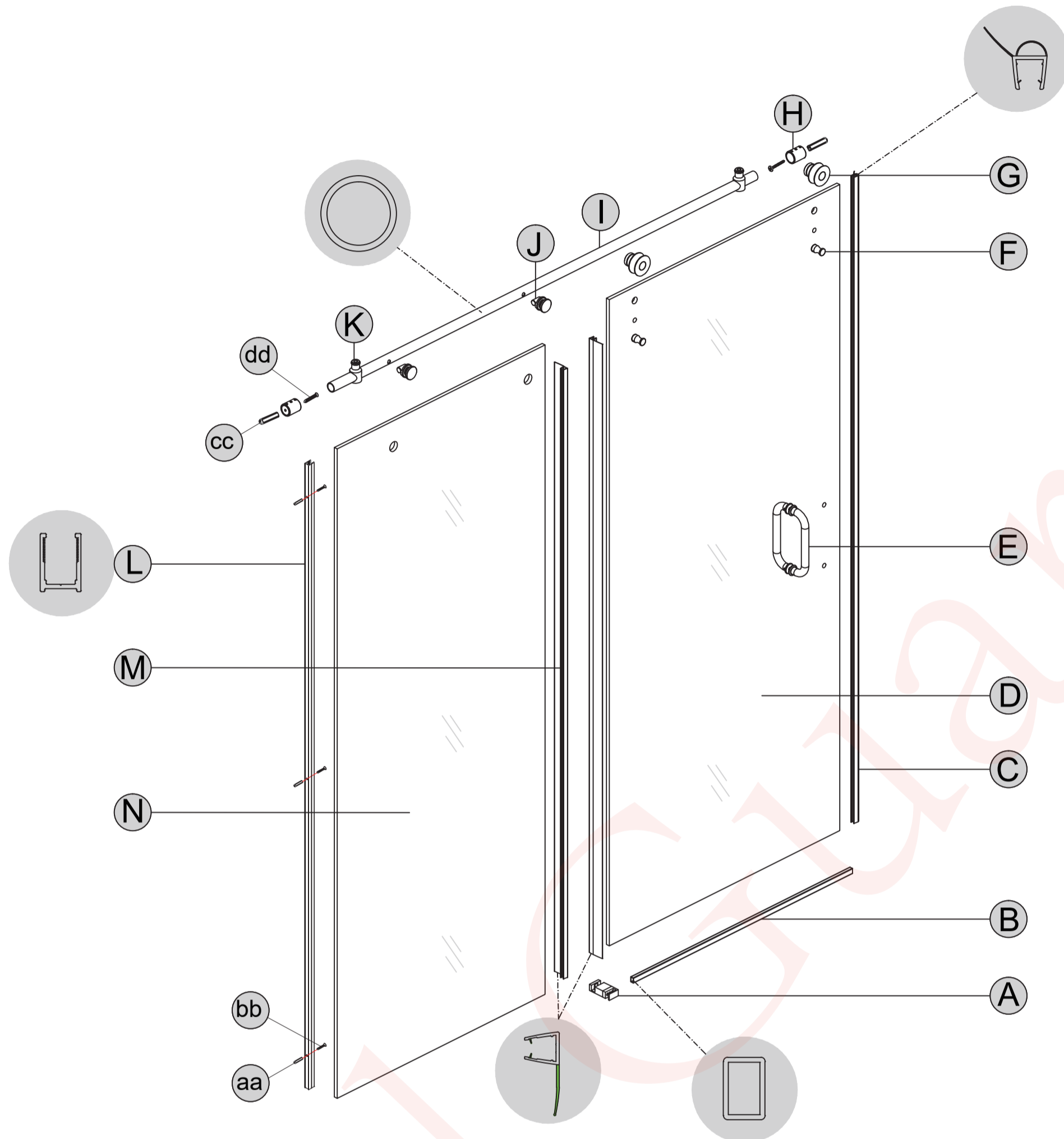
To minimize these risks, please note:

- Always wear safety glasses and gloves while handling.
- Always follow the installation instructions.
- Inspect glass for damage before installation.
- Extreme caution should be taken while handling the glass during installation as the tempered glass may shatter if in contact with a hard surface.
- Do not cut or modify the tempered glass as it will shatter if cut.
- Carefully remove product from packaging and keep packaging until installation is complete.
- Inspect all parts for damage or missing; if there is damage or part missing to the unit prior to installation, please contact customer service at the number provided in this guide.
- Cover the drain with tape to prevent the loss of small parts.
- The shower base and finished walls should be installed before beginning the shower door installation.
- During the installation, protect the shower floor with a drop cloth to avoid damage.
- This product should be installed by two people who are familiar with construction requirements. Professional installation is recommended!
- Keep this installation manual for future reference.

**NOTE:** Two people should perform this installation.



# DOOR ASSEMBLY



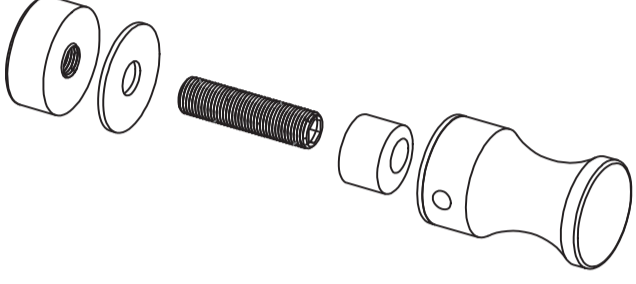
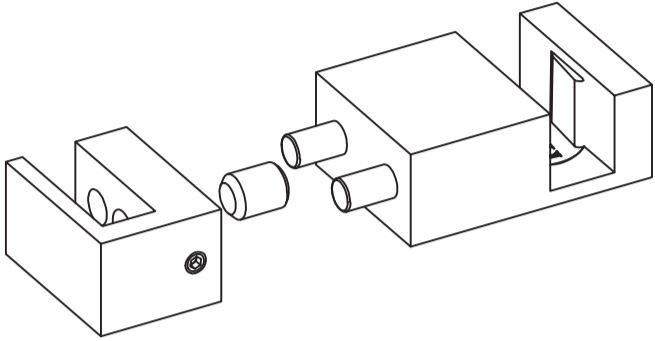
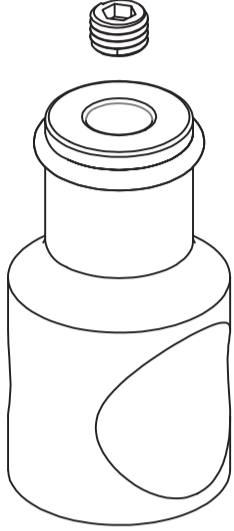
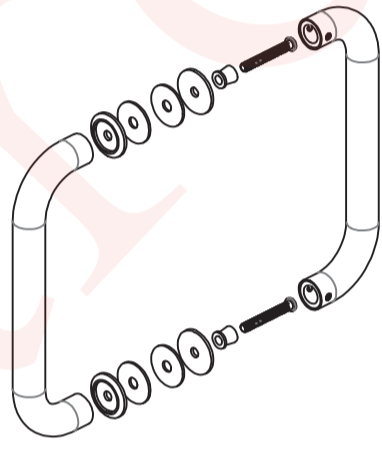
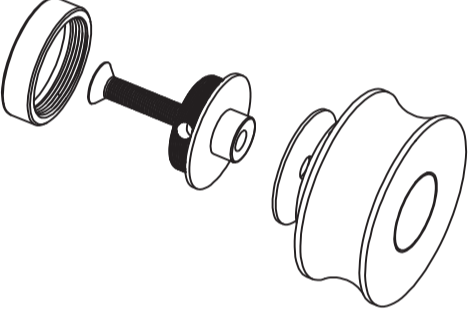
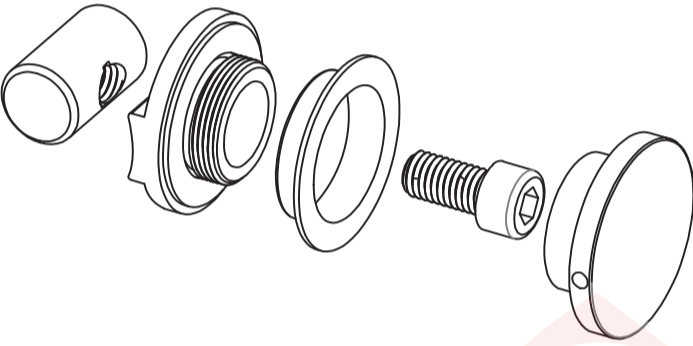
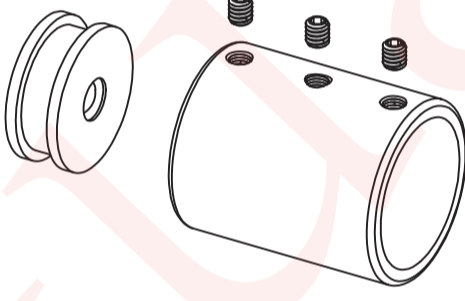
## CARTON PARTS IDENTIFICATION

See following pages for detailed component diagrams

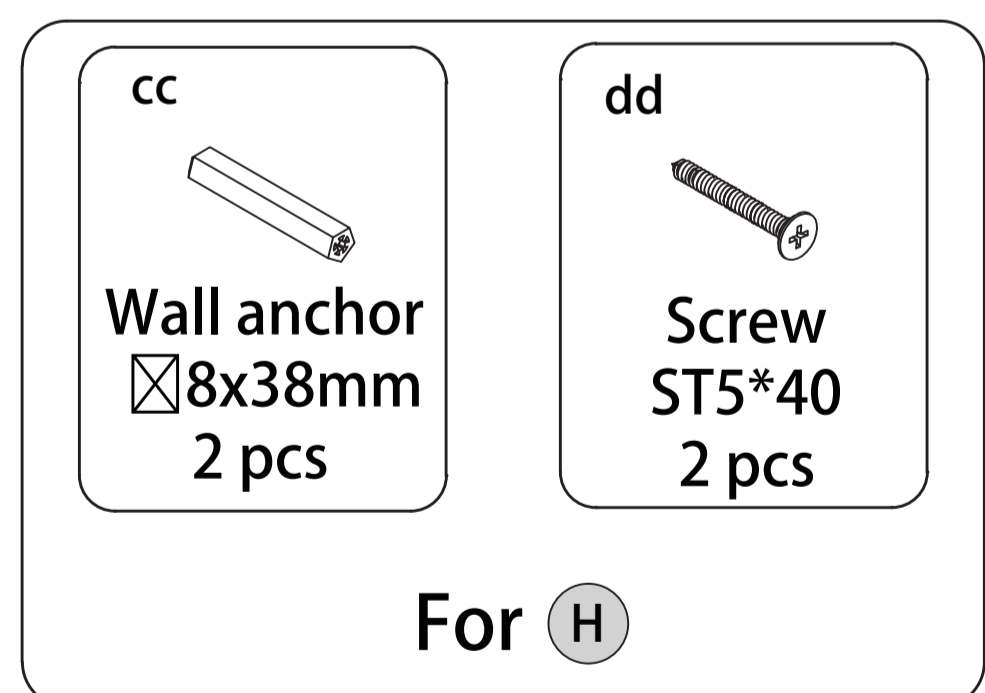
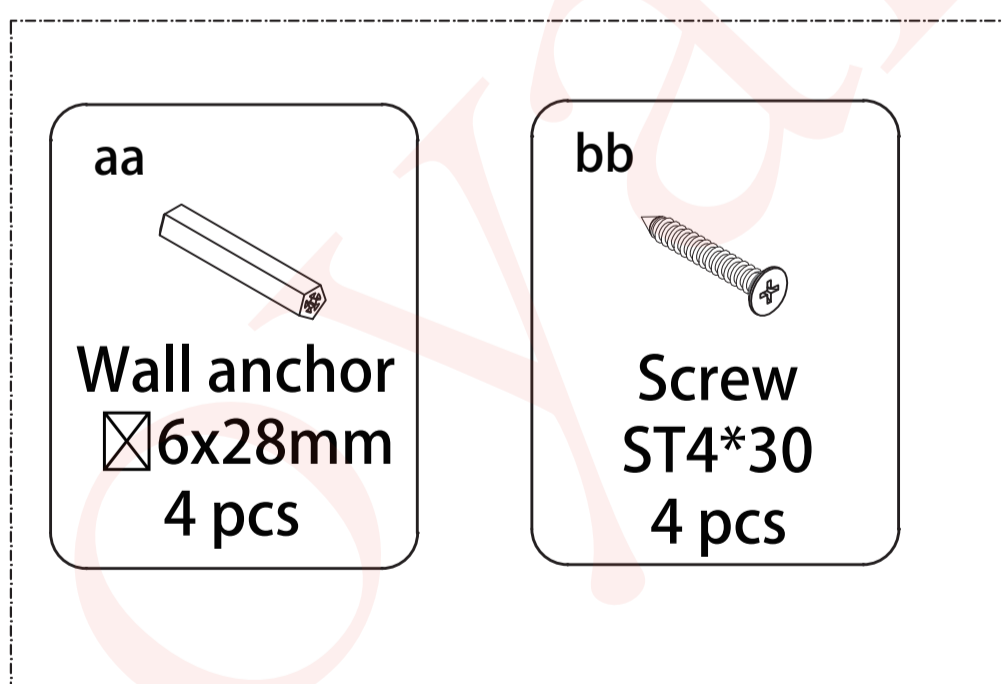
PART#	DESCRIPTION	QTY	PART#	DESCRIPTION	QTY
A	Guide Block	1	H	Guide Rail Brackets	2
B	Anti-Splash Guard	1	I	Upper Guide Rail	1
C	Bumper Strip	1	J	Glass Brackets	2
D	Glass door	1	K	Door Stoppers	2
E	Handle	1	L	Wall Jamb	1
F	Roller Guards	2	M	Anti-Water Strips	2
G	Rollers	2	N	Stationary Glass	1

## CARTON PARTS IDENTIFICATION

See following pages for detailed component diagrams

 <p><b>F X2</b> Roller Guards</p>	 <p><b>A X1</b> Guide Block</p>	 <p><b>K X2</b> Door Stoppers</p>	 <p><b>E X1</b> Handle</p>
 <p><b>G X2</b> Rollers</p>	 <p><b>J X2</b> Glass Brackets</p>	 <p><b>H X2</b> Guide Rail Brackets</p>	

## HARDWARE CONTENT

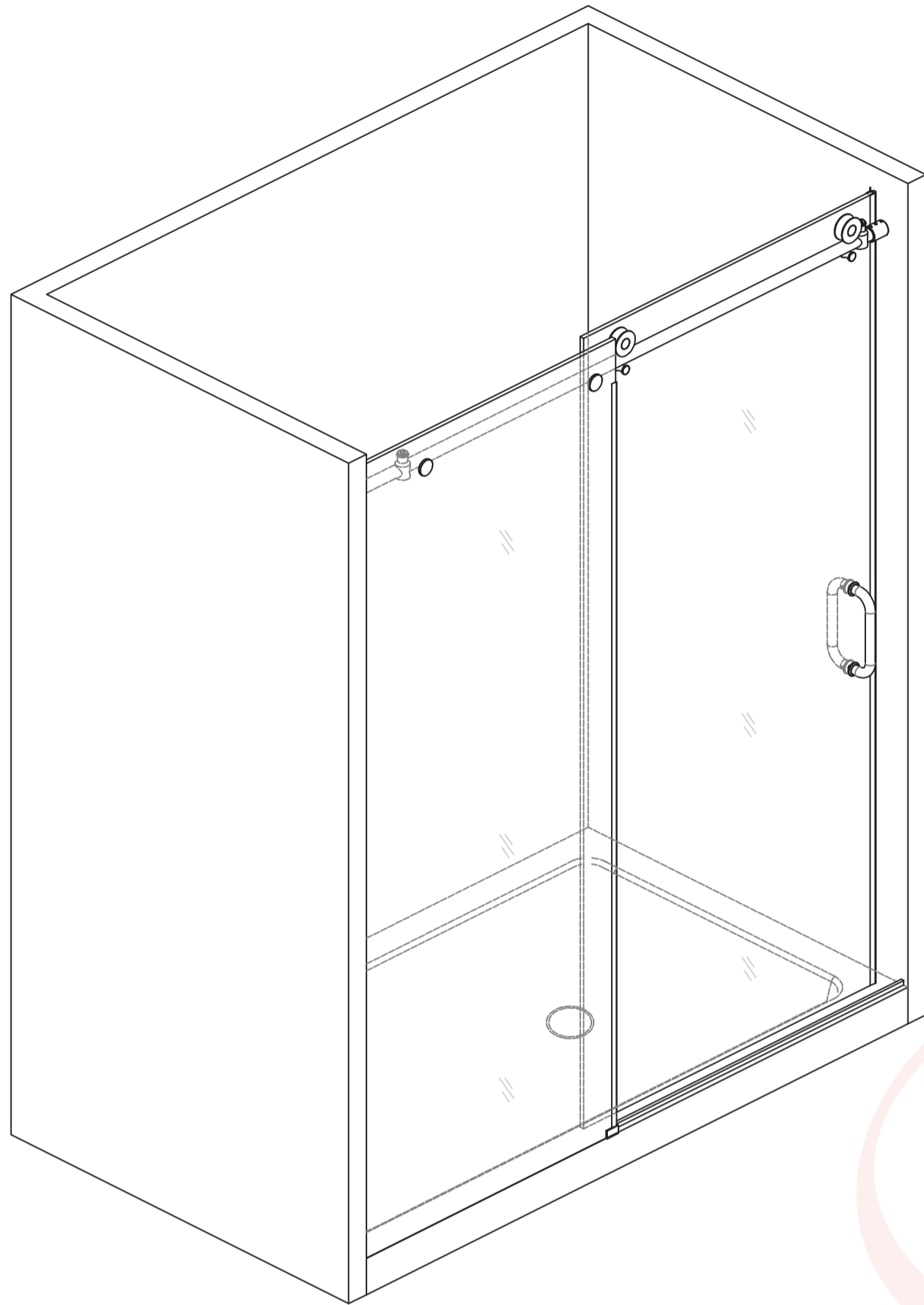


Additional spare parts are included.

**NOTE: Inspect all parts for missing prior to installation!  
Contact us for any part missing.**



**CAUTION:** To avoid personal injury or property damage, identify components and read all instructions before installing.

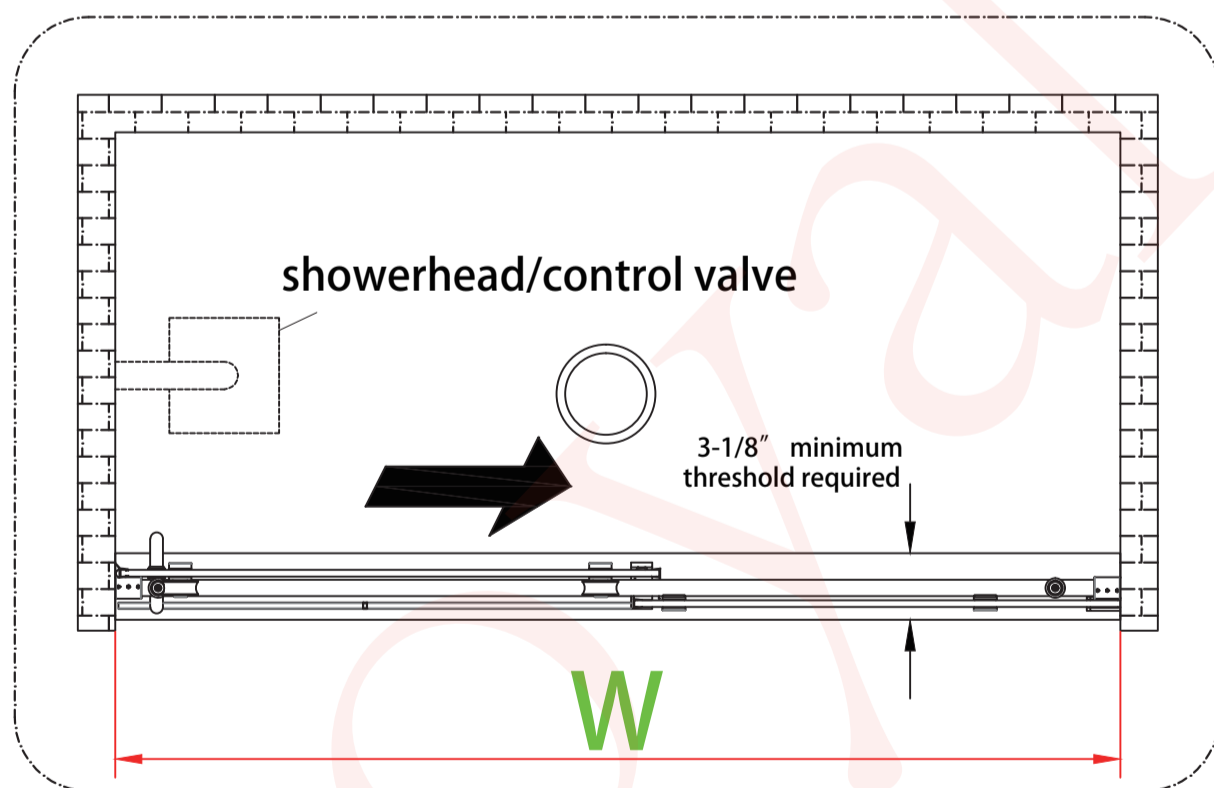


**NOTE:** Door height is 74" (188 cm). Recommended Clearance Height for installation is 76" (193 cm.)

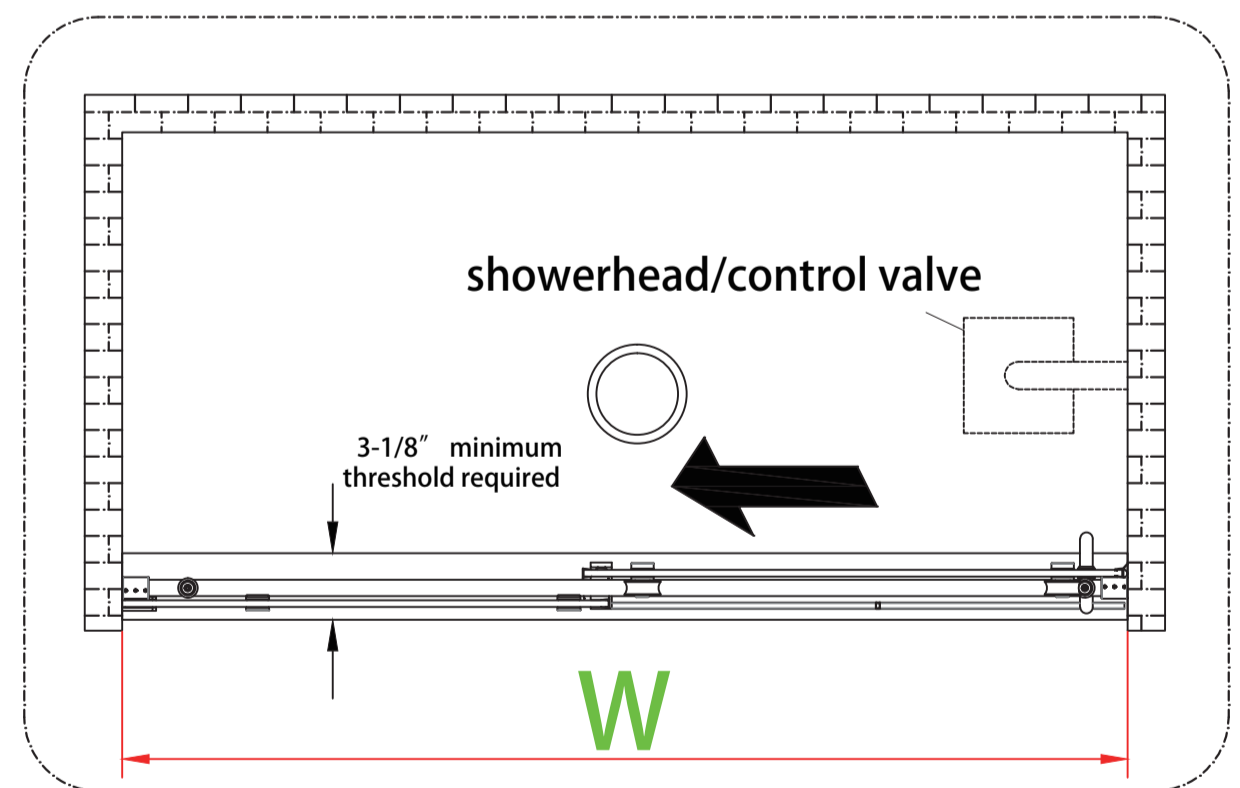
This Commix Exposed Roller Shower Door can be installed to open from either side of your enclosure depending on showerhead/control valve location.

The Glass Door should be installed on the same side as showerhead/control valve for optimal water retention.

**NOTE:** For the purposes of these instructions, the installation will be shown with the Glass Door (E) to the left of the enclosure.



**Left-hand Door**



**Right-hand Door**

enclosure	value range(W)
48-inch	46 - 48 3/16inches
60-inch	58 - 60 3/16inches

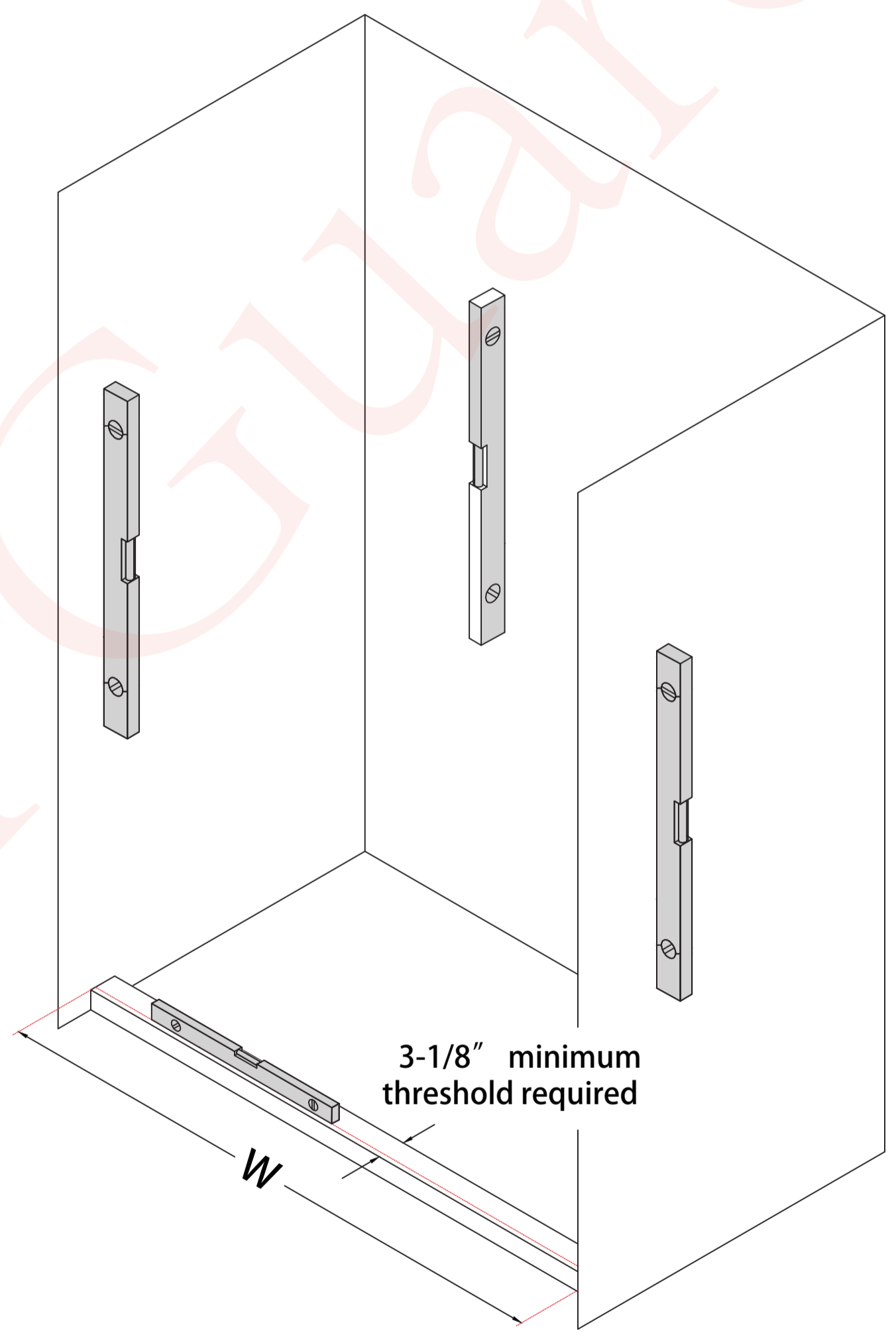
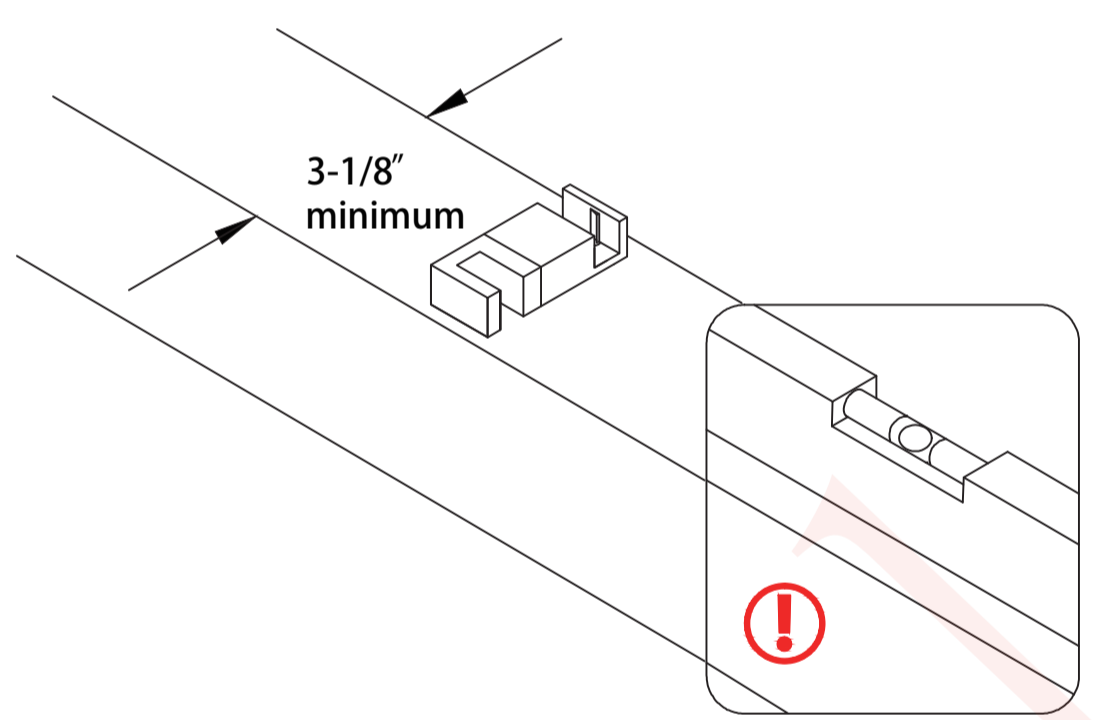


**NOTE: DOOR Glass** should be installed on the same side of Shower head.

**!** When constructing or installing a shower base, consider how the thickness of the wall treatment (wallboard, tile, etc.) will affect where the shower enclosure will sit on the threshold. Compare the overall outside dimensions of the shower enclosure model size as shown on the "Shower Enclosure Plan" with the finished threshold before proceeding with the installation.

1/4" (6mm) Out-of-Plumb Adjustment within the Wall Profile; Verify threshold and walls with a level.

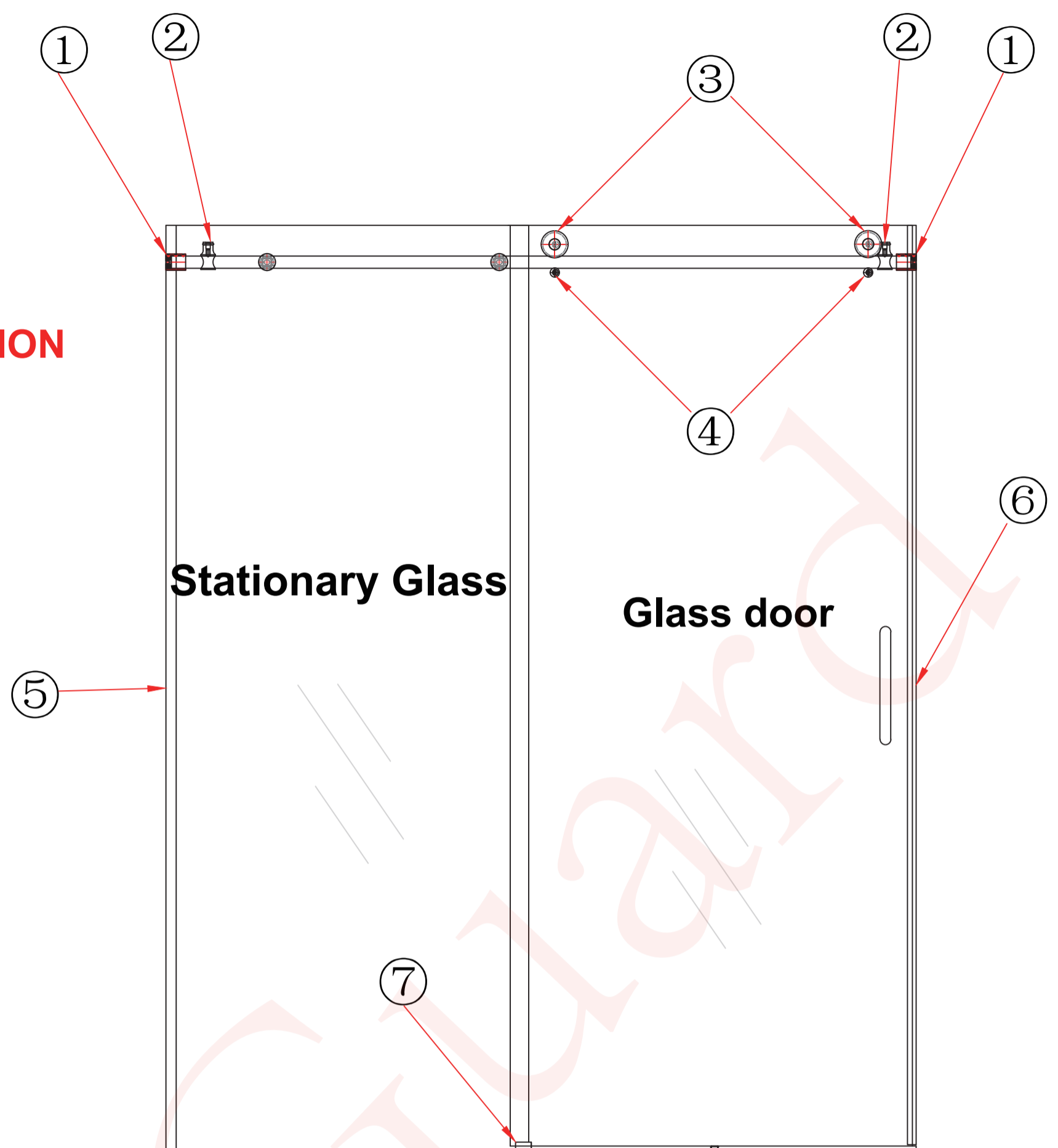
**!** Note: The minimum threshold requirement is 3-1/8" of flat threshold space.



enclosure	value range(W)
48-inch	46 - 48 3/16inches
60-inch	58 - 60 3/16inches



**IMPORTANT INFORMATION  
REGARDING THE INSTALLATION  
OF THIS SHOWER DOOR**



**Left hand door installation shown as an example**

- ① **Guide Rail Brackets** must be firmly attached to the wall. Installation into a stud is strongly recommended. All of the guide rail bracket set screws must be tightened.
- ② Thread Lock must be applied to both **Stopper Set Screws** . Panel-side and Door-side **Stoppers** must be installed at the proper position to stop the door from contacting the wall.
- ③ **Roller Wheel Big Bolt** must be re-tightened after installation.
- ④ **Roller Guards** must be positioned and secured within 1/16" of **Upper Guide Rail** .
- ⑤ **Wall Jamb** must be installed vertically to ensure that the installation is stable and secure, and the screws should be tightened.
- ⑥ **Bumper Strip** must be installed on the closing edge of the **Glass Door** .
- ⑦ **The Guide Block** installed square to the **Stationary Glass** and **Glass Door** . Installing the guide block crooked may damage the bottom edge of the **Glass Door** and lead to breakage.

**PLEASE READ THE ENCLOSED INSTALLATION  
MANUAL FOR DETAILS REGARDING PROPER  
INSTALLATION.**

## Installation steps

**CAUTION:** When cutting or drilling metal components or when handling glass, to reduce the risk of personal injury, protective eye wear, gloves, and closed-toe shoes are required.

- 1 Measure the distance from the finished wall to the finished wall . This distance will represent the finished opening size “W” that will be used to calculate the finished cut dimension for the **Upper Guide Rail (I)**. (Fig 1)

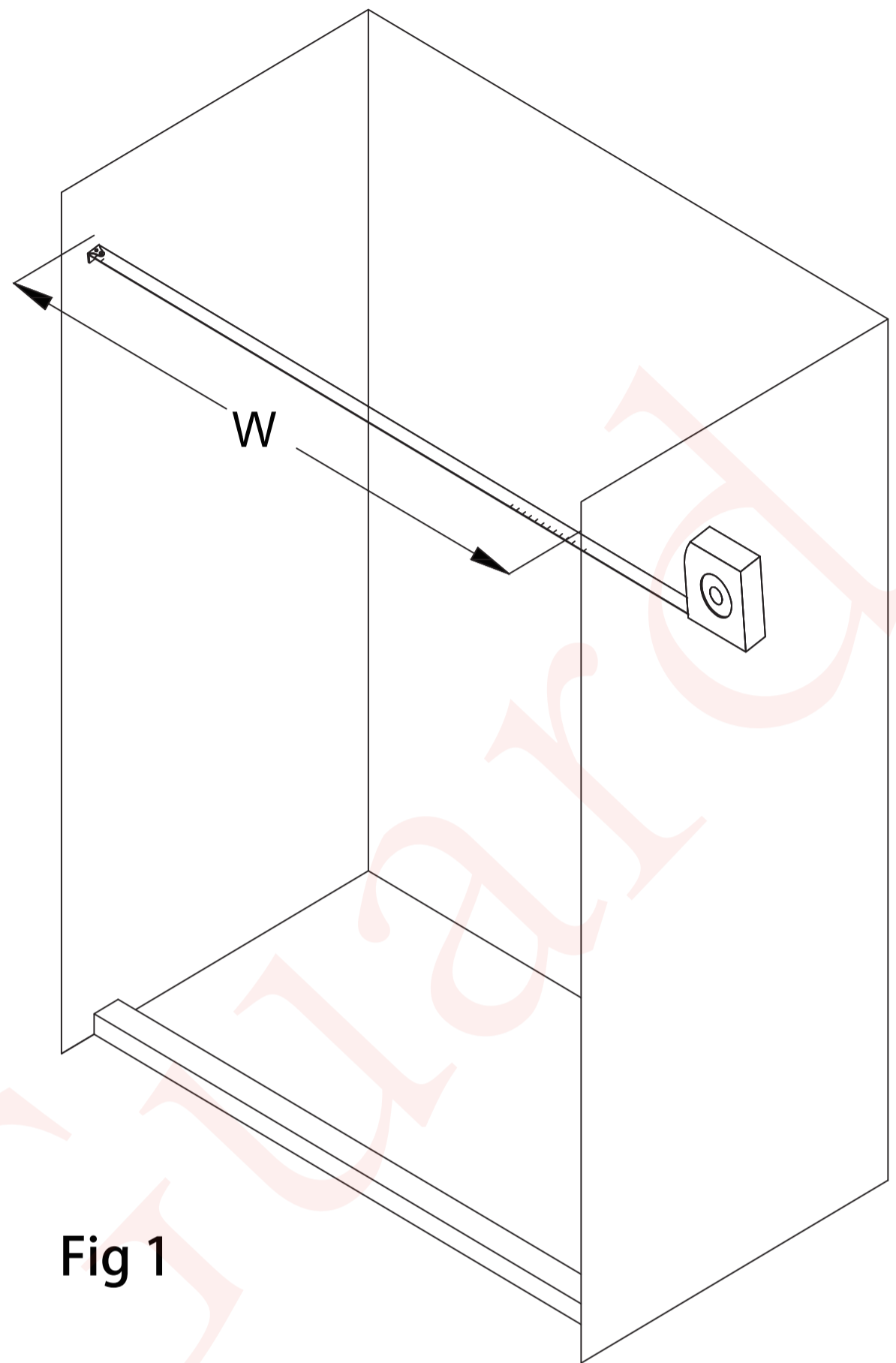


Fig 1

- 2 The **Upper Guide Rail (I)** has been pre-cut for the model width of 60". (Note: The actual rail is shorter than the model width by design).

Cut the **Upper Guide Rail (I)** from the door end only, which is the end that is farther from the **Glass Bracket (J)** holes. Use a metal file to remove any burrs from the cut end. (Fig 2)

The length to cut off will be (X):  
 $\text{Model Width} - \text{opening } W = \text{cut off length } (X)$

### FOR EXAMPLE

If the model width is 60" and the finished opening from the finished wall to the inside surface of the finished wall is 58", then you will need to cut 2" off from the door end of the Guide Rail. **Example:**  $60" - 58" = 2"$  cut off

\*Note that this is only an example and the actual cut-off length will vary based on the actual finished opening dimension.

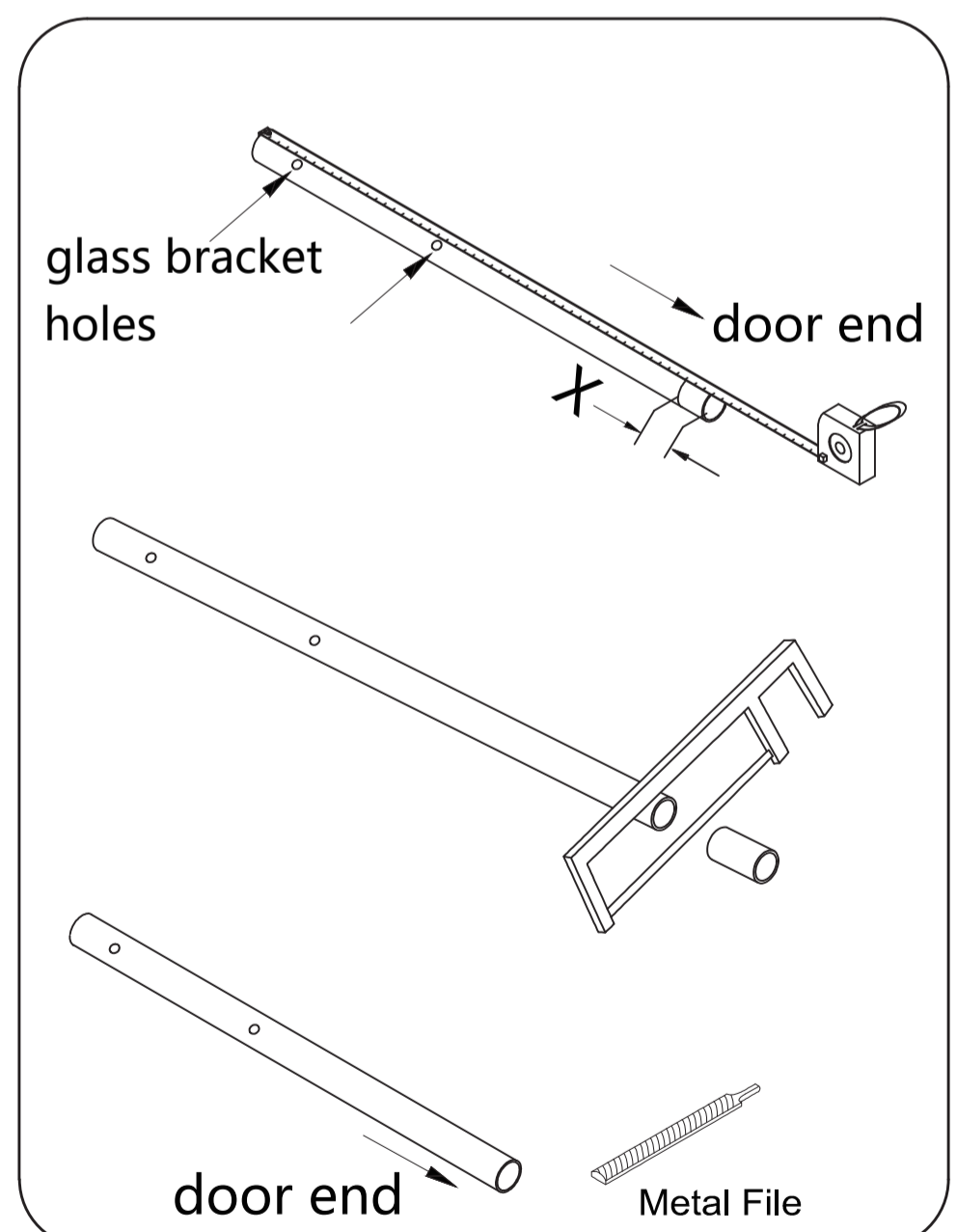
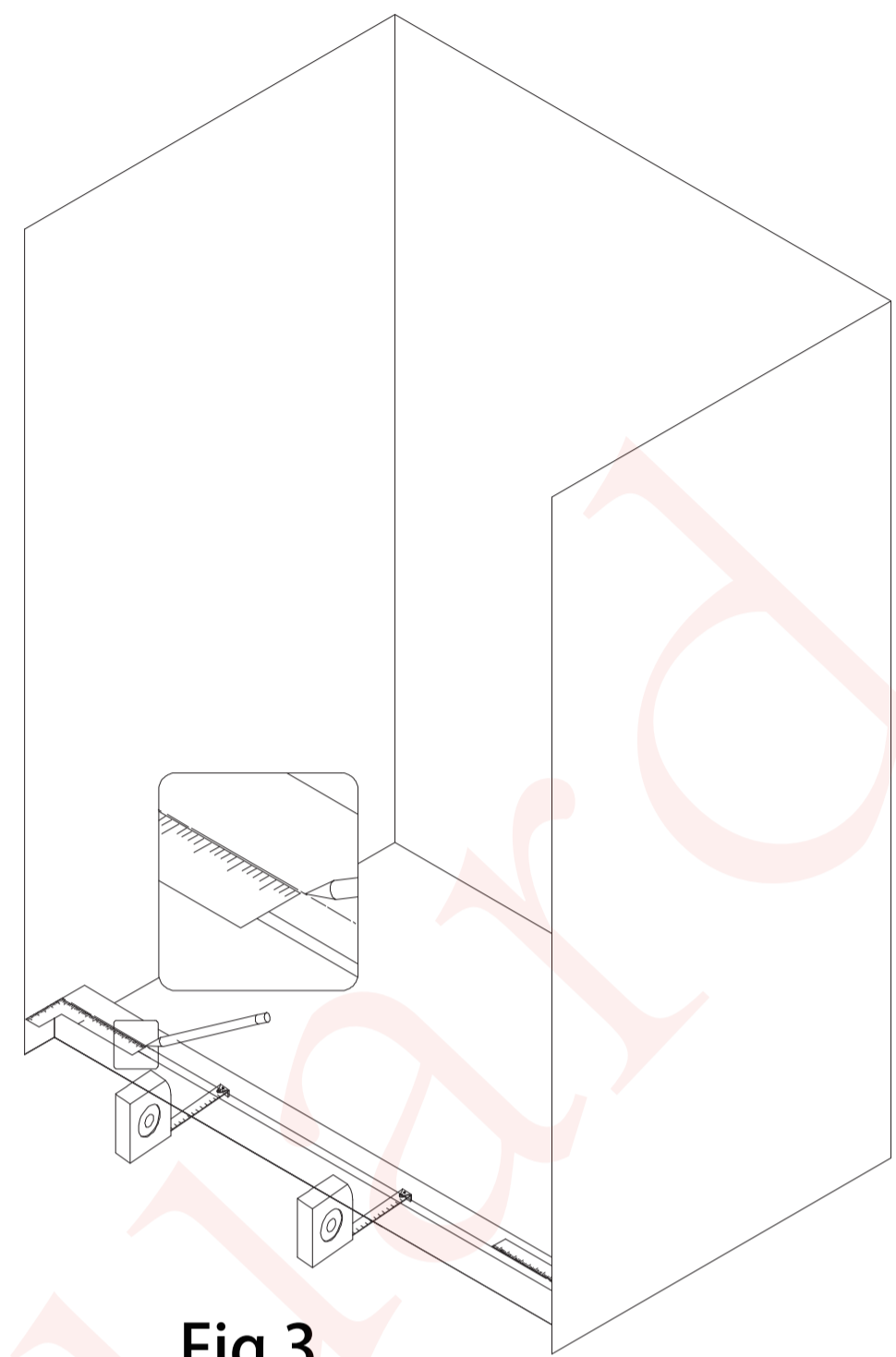
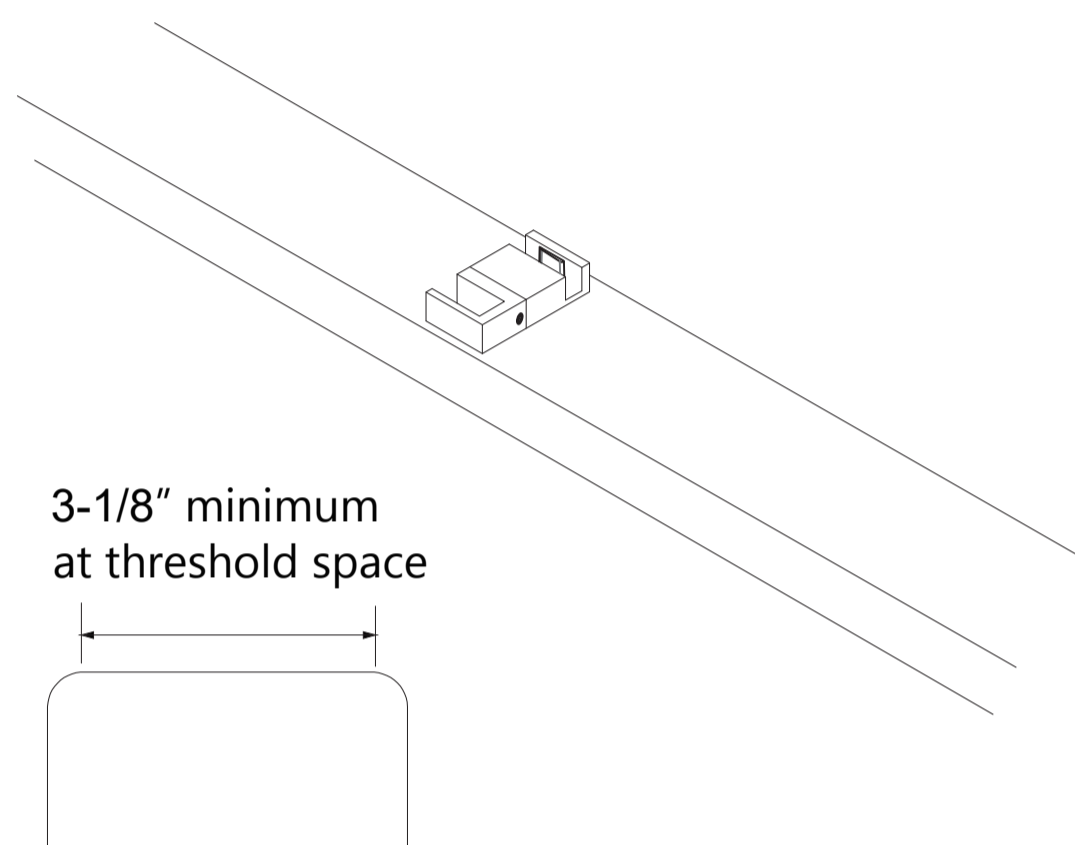


Fig 2

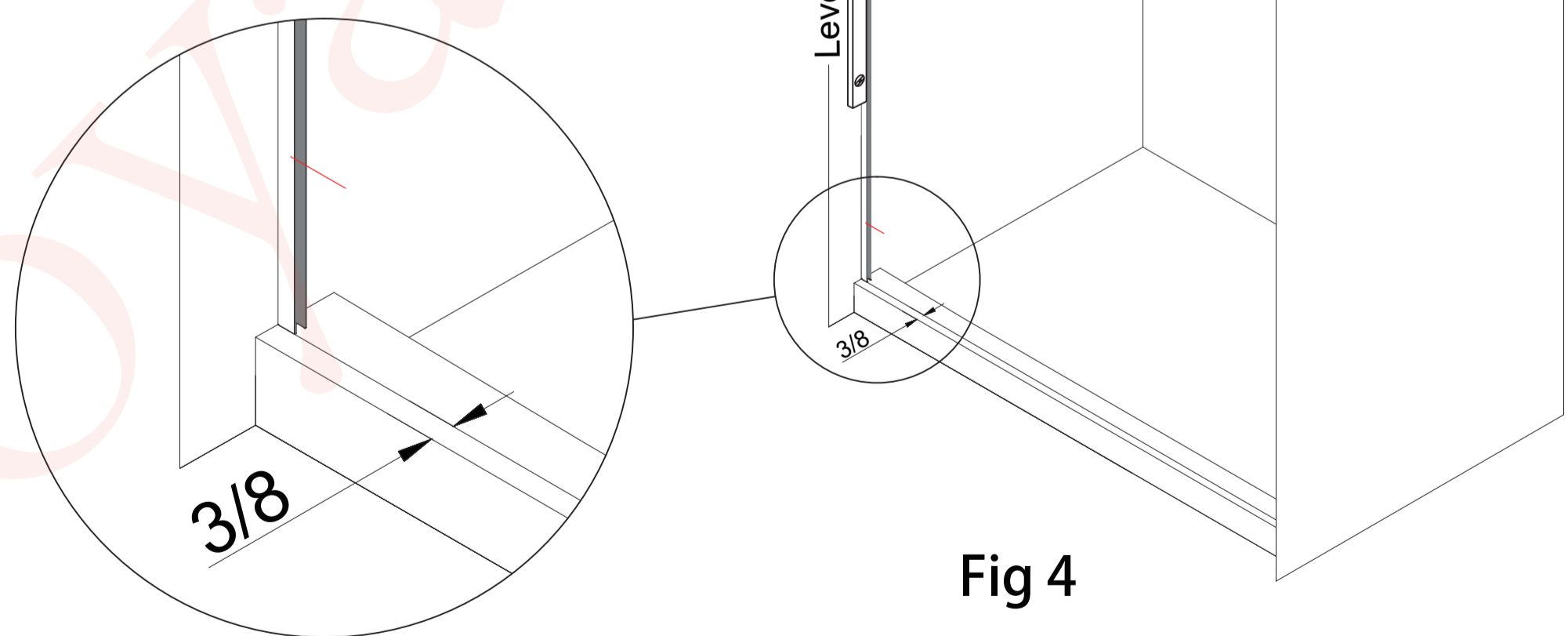
**CAUTION:** When cutting or drilling metal components or when handling glass, to reduce the risk of personal injury, protective eye wear, gloves, and closed-toe shoes are required.

**3** This model requires a minimum 3-1/8" of flat threshold space for installation.

Starting from the wall on the stationary panel side, use a Carpenter's Square as a guide and draw a reference line on the threshold. (Fig 3)



**4** Align the outside edge of the **Wall Jamb (L)** with the inside of the mark on the threshold. Use a level to plumb the **Wall Jamb (L)** and mark its position on the wall. Mark the three holes for drilling through the pre-drilled holes in the **Wall Jamb (L)**. (Fig 4)



**5** Remove the **Wall Jamb (L)** from the wall and drill the anchor holes using a  $\varnothing 1/4"$  drill bit and insert the **Wall Anchors (aa)** . Attach it to the wall using three of the **Screw ST4\*30 Countersunk Screws (bb)** . (Fig 5)

- ! • If a stud is presented behind the wall: drill a  $\varnothing 1/8"$  (3mm) pilot hole into the stud and use the ST4.0 x 30mm Screws (bb) OR
- If no stud is presented behind the wall: drill a  $\varnothing 1/4"$  (6mm) hole and insert the **Wall Anchors (aa)** and use the ST4.0 x 30mm Screws (bb).

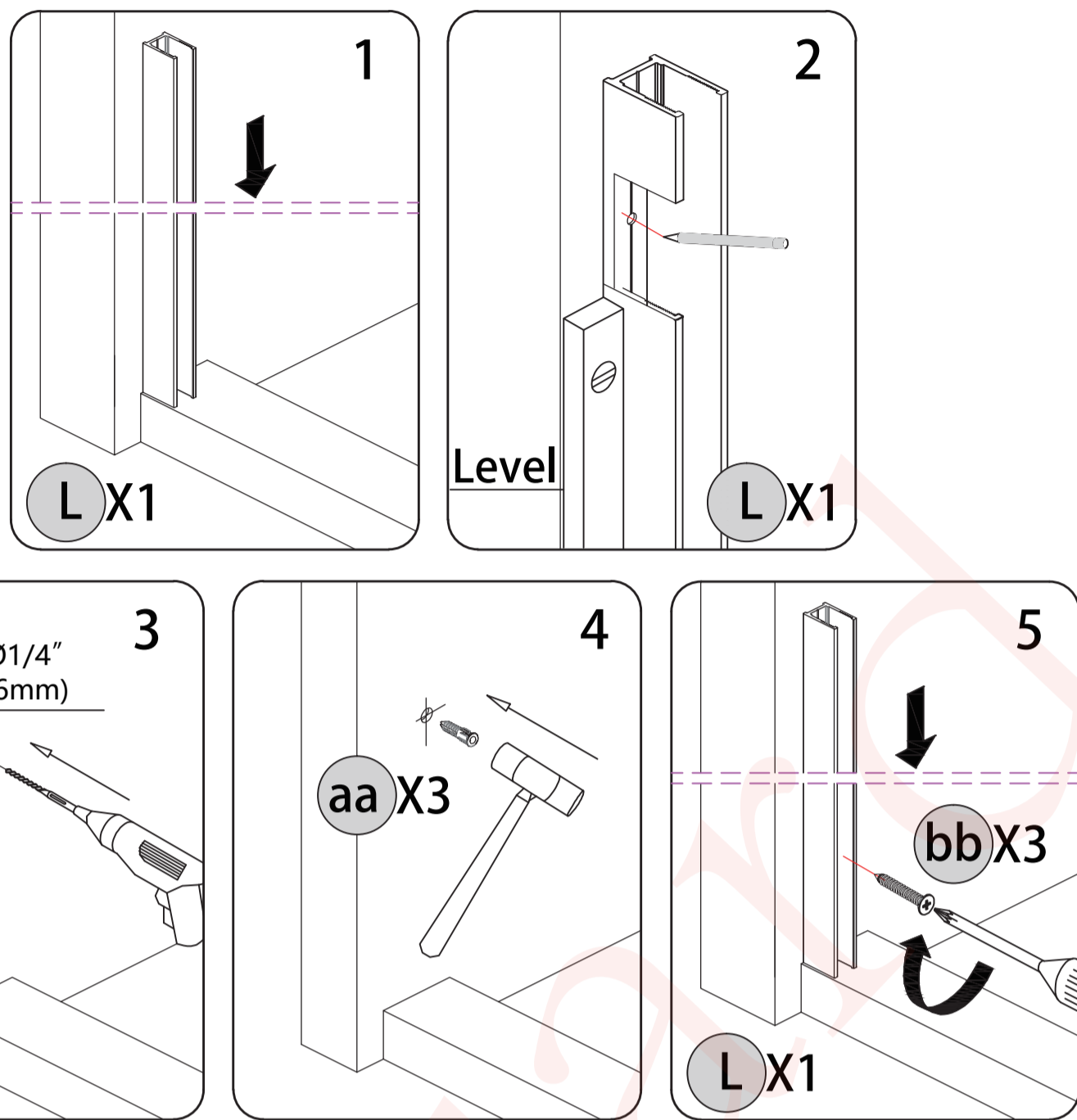


Fig5

**CAUTION:** When cutting or drilling metal components or when handling glass, to reduce the risk of personal injury, protective eye wear, gloves, and closed-toe shoes are required.

**6** Take the top of **Wall Jamb (L)** as the reference, mark the hole position according to the size in the figure.(Fig 6.1)  
 Drill the anchor holes using a  $\varnothing 5/16"$  drill bit (Fig 6.2) and insert the **Wall Anchors (cc)** . (Fig 6.3)  
 Attach the base part of **Guide Rail Bracket (H)** to the wall using the **ST5 X 40 Screw (dd)** .(Fig 6.4)

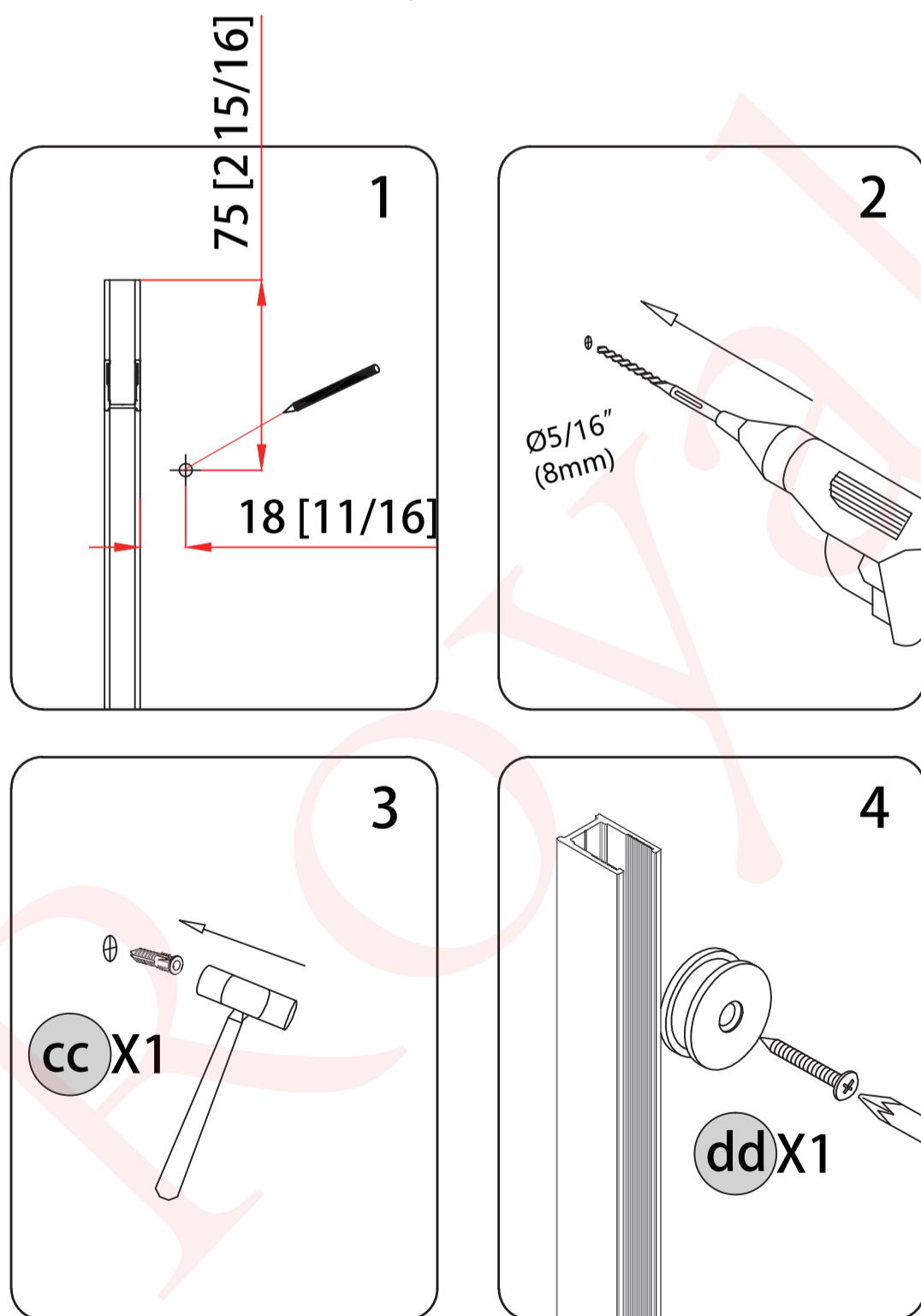
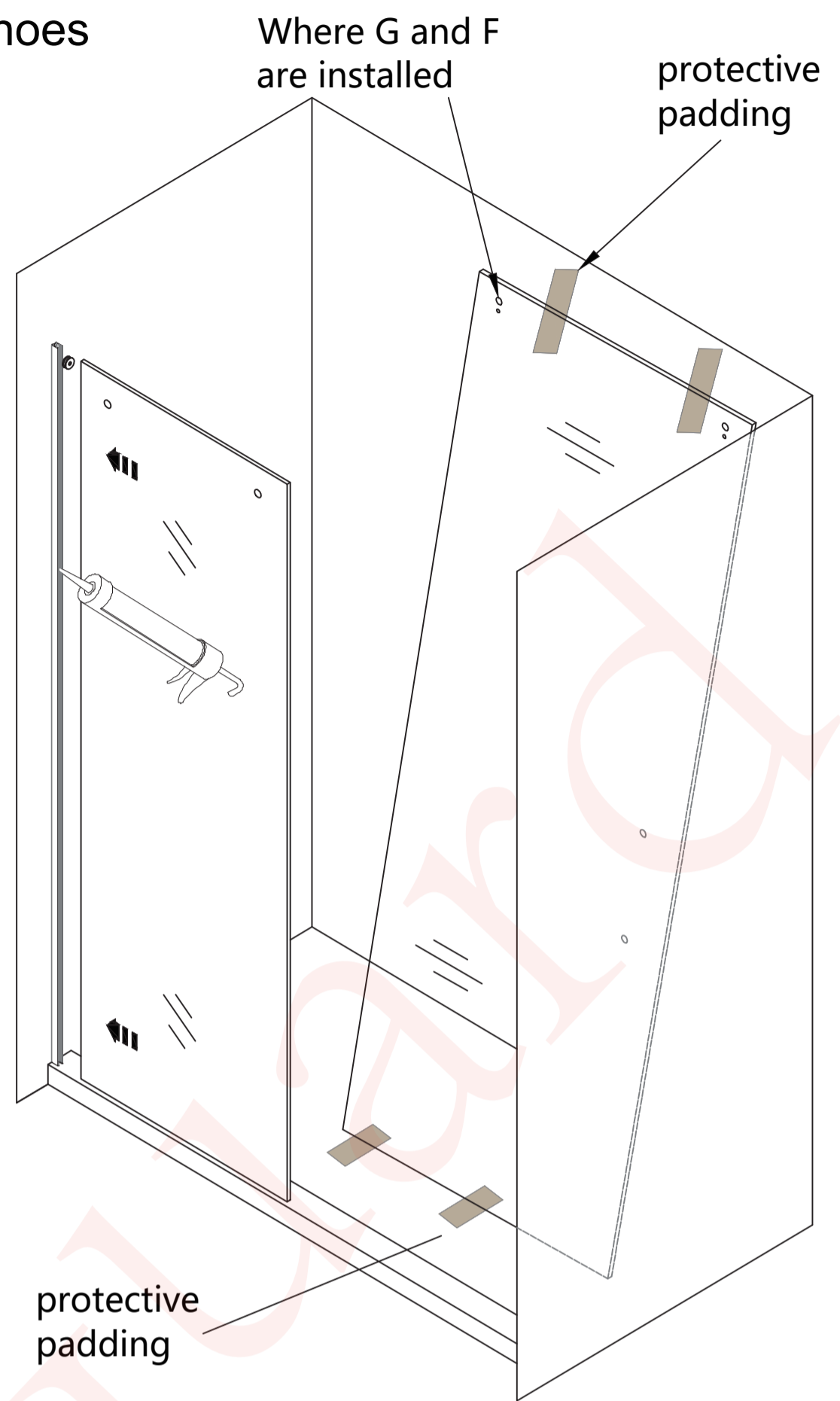
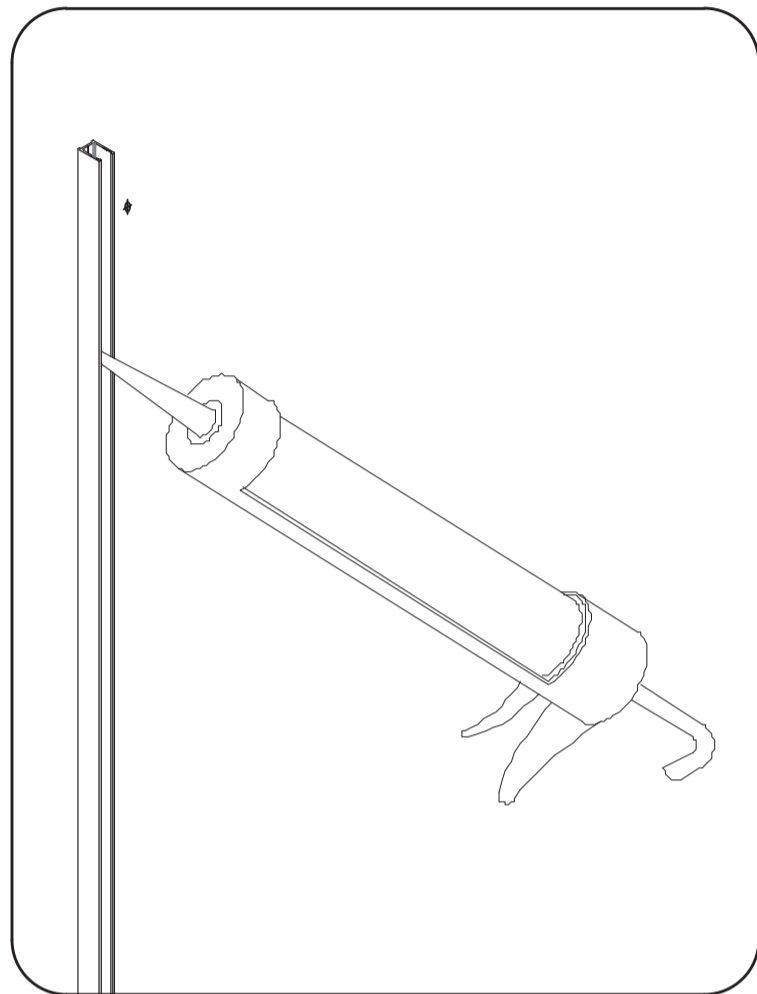


Fig 6

- ! • If a stud is presented behind the wall: drill a  $\varnothing 5/32"$  (4mm) pilot hole into the stud and use the ST5.0 x 40mm Screws (dd) OR
- If no stud is presented behind the wall: drill a  $\varnothing 5/16"$  (8mm) hole and insert the **Wall Anchors (cc)** and use the ST5.0 x 40mm Screws (dd).

**CAUTION:** When cutting or drilling metal components or when handling glass, to reduce the risk of personal injury, protective eye wear, gloves, and closed-toe shoes are required.

- 7** Apply silicone into the **Wall Jamb (L)**. Slide the **Stationary Glass (N)** firmly into the installed **Wall Jamb (L)**. (Fig 7)



**Fig7**

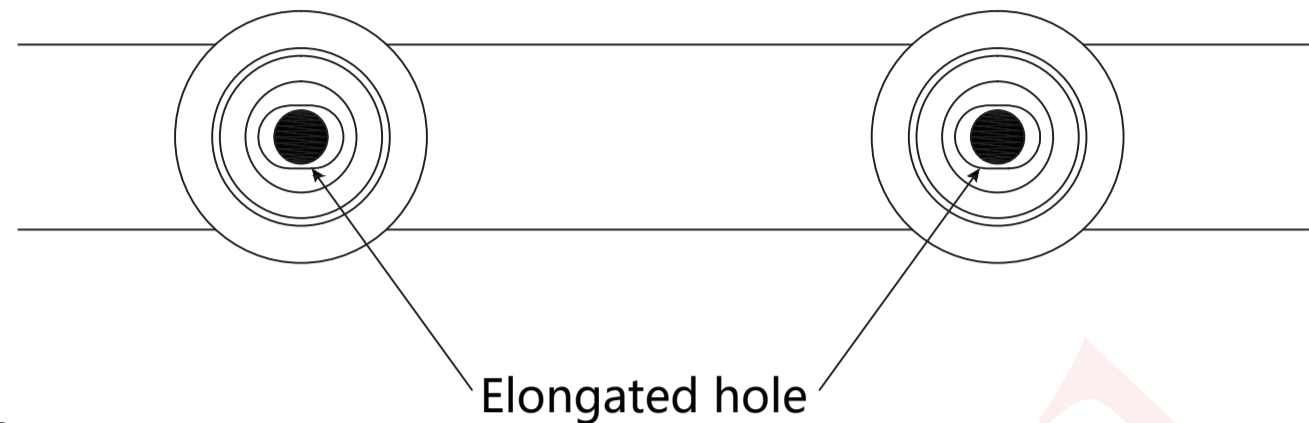
**NOTE:** Before installing the **Stationary Glass (N)**, take the **Door Glass (D)** into the shower area and lean it against the wall with the handle holes on the correct side. (For example, the movable door is installed on the right, and the handle holes are located on the right.) After the **Stationary Glass (N)** is installed, it may not be possible to easily get the door glass into the shower. Always use padding to protect the glass and shower surfaces.

**NOTE:** There are 4 holes at one end of the glass for installing **Rollers (G)** and **Roller Guards (F)**, so this end should be placed upward.

**NOTE: DO NOT** attach the handle to the door glass until instructed. **DO NOT** attempt to lift the door glass with the handle as this may result in damage to the glass and/or serious personal injury. Use a professional grade glass suction cup and an assistant.

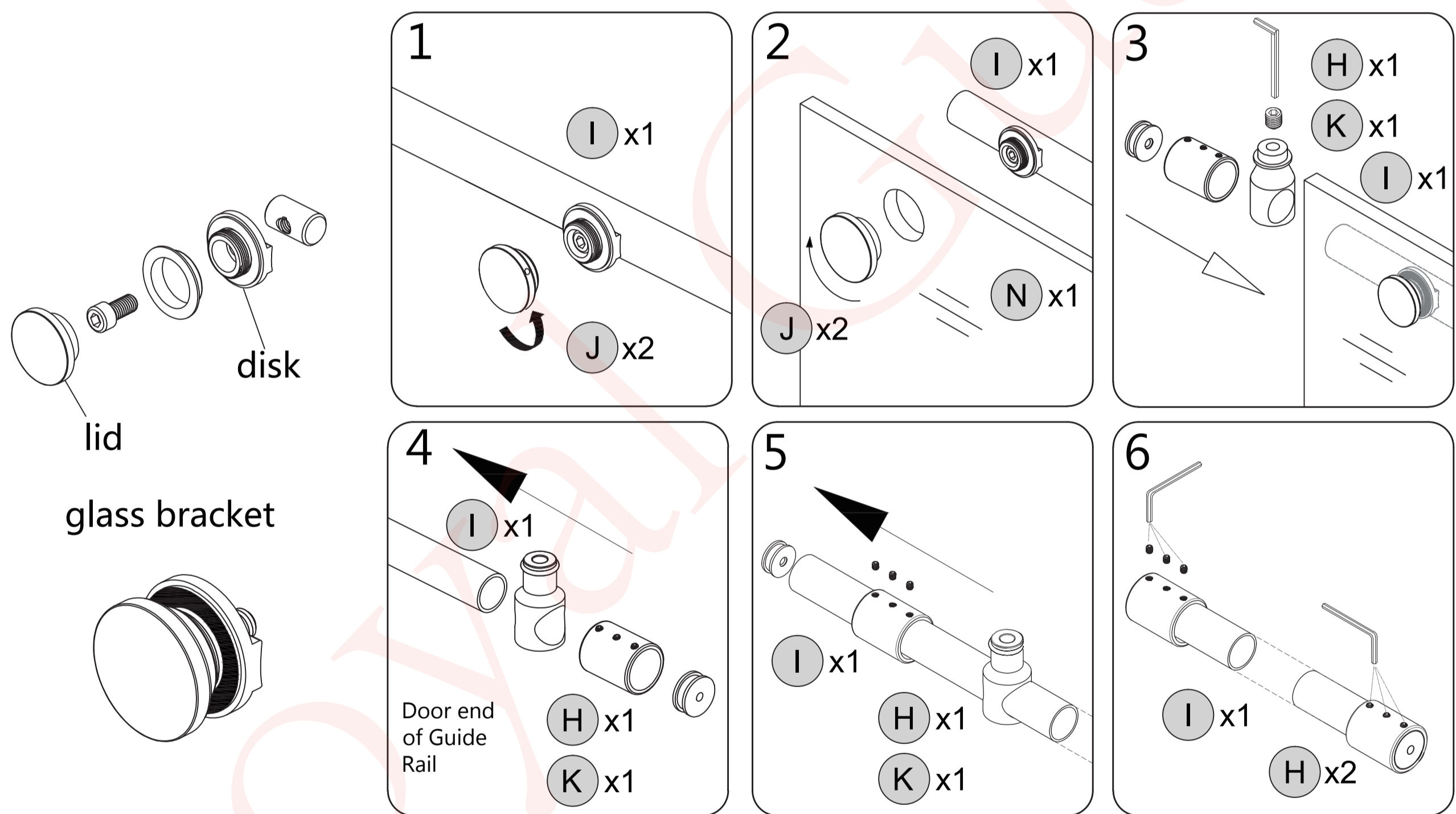
**CAUTION:** When cutting or drilling metal components or when handling glass, to reduce the risk of personal injury, protective eye wear, gloves, and closed-toe shoes are required.

**8-1** Attach the **Upper Guide Rail (I)** to the **Stationary Glass (N)** with the **Glass Brackets (J)** and tighten the bolts into the predrilled holes in the **Upper Guide Rail (I)**. Make sure that the guide rail is attached parallel with the top edge of the **Stationary Glass (N)**.



**NOTE:** The glass bracket disk has an elongated one for adjusting the left and right.

**8-2** First, remove the **Glass Brackets (J)** installed on the **Upper Guide Rail (I)** to get lid. (Fig 8.1) Install the **Upper Guide Rail (I)** onto the **Stationary Glass (N)** and tighten the lid. (Fig 8.2) Slide the **Door Stoppers (K)** onto each end of the **Upper Guide Rail (I)** and secure them using the 4mm hex Wrench.(Fig 8.3 and Fig 8.4)



**Fig 8**

**8-3** Slide the **Guide Rail Brackets (H)** onto each end of the **Upper Guide Rail (I)** and secure them.(Fig 8.5 and Fig 8.6)

**9**

Place the **Stationary Glass (N)** with the **Upper Guide Rail (I)** onto the threshold and position it against the wall.

Make sure the **Stationary Glass (N)** and the **Upper Guide Rail (I)** are level. Once the **Upper Guide Rail (I)** is level, mark the position of the **Guide Rail Bracket (H)** on the wall. (Fig 9)

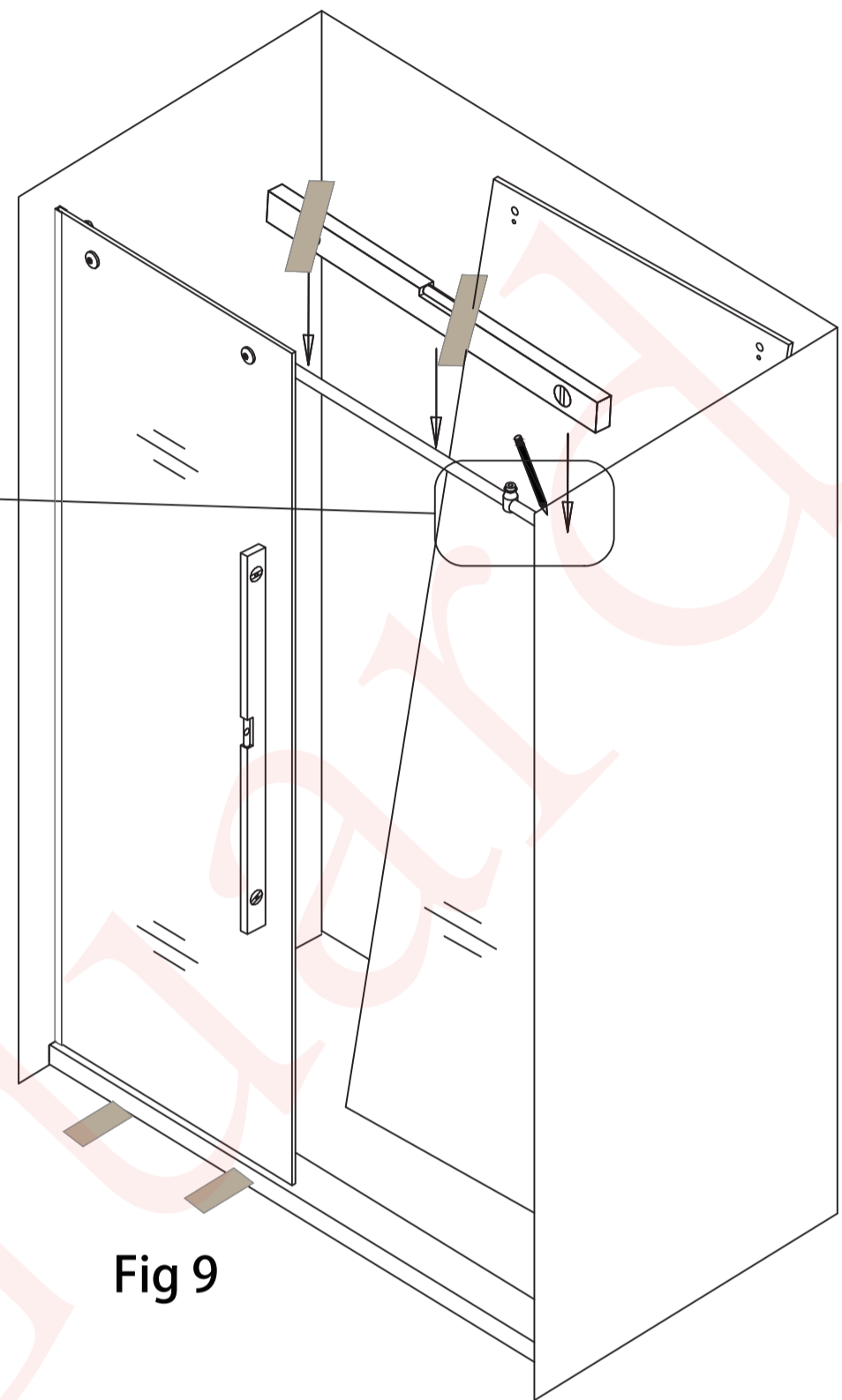
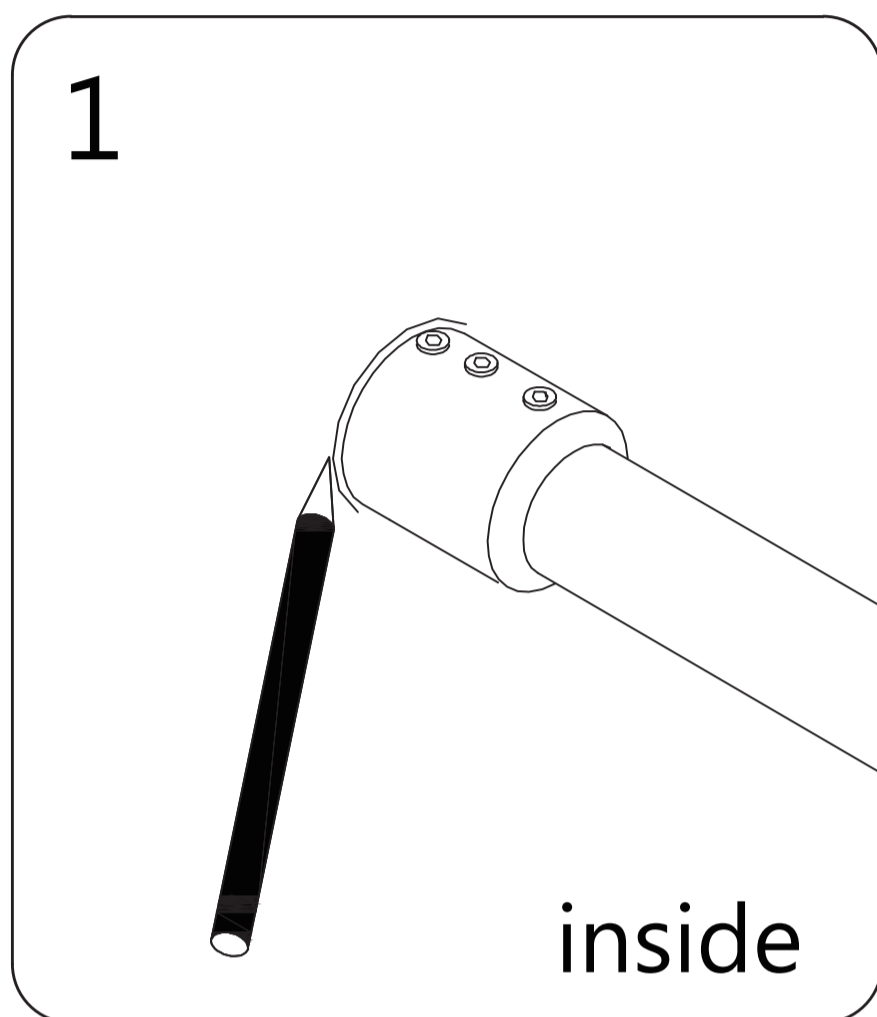


Fig 9

**CAUTION:** When cutting or drilling metal components or when handling glass, to reduce the risk of personal injury, protective eye wear, gloves, and closed-toe shoes are required.

**10**

After marking the position of the hardware, remove the **Guide Rail (I)** from the **Stationary Panel Glass (N)**. Remove the **Guide Rail Bracket (H)** from the **Guide Rail (I)** and hold it back in position on the wall and mark the anchor. Drill either a  $\text{Ø}5/16''$  hole and insert a **Wall Anchor (cc)**. Attach the base part of **Guide Rail Bracket (H)** to the wall using the **ST5 × 40 Screw (dd)**. (Fig 10.4)

- If a Stud is present behind the wall:  
drill a  $\text{Ø}5/32''$  (4mm) hole up to the stud, use the ST5 x 40 Screws (dd)

OR

- If No Stud is present behind the wall:  
drill a  $\text{Ø}5/16''$  (8mm) hole and insert the wall anchors (ee) and use the ST5 x 40 Screws (dd) attach the wall bracket assemblies.

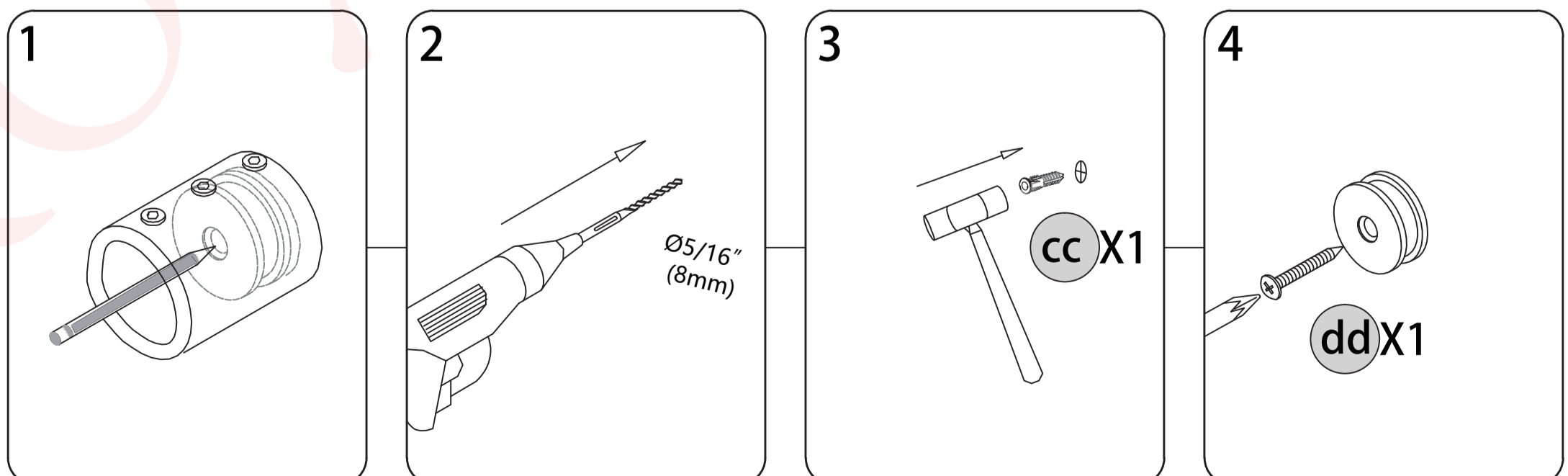
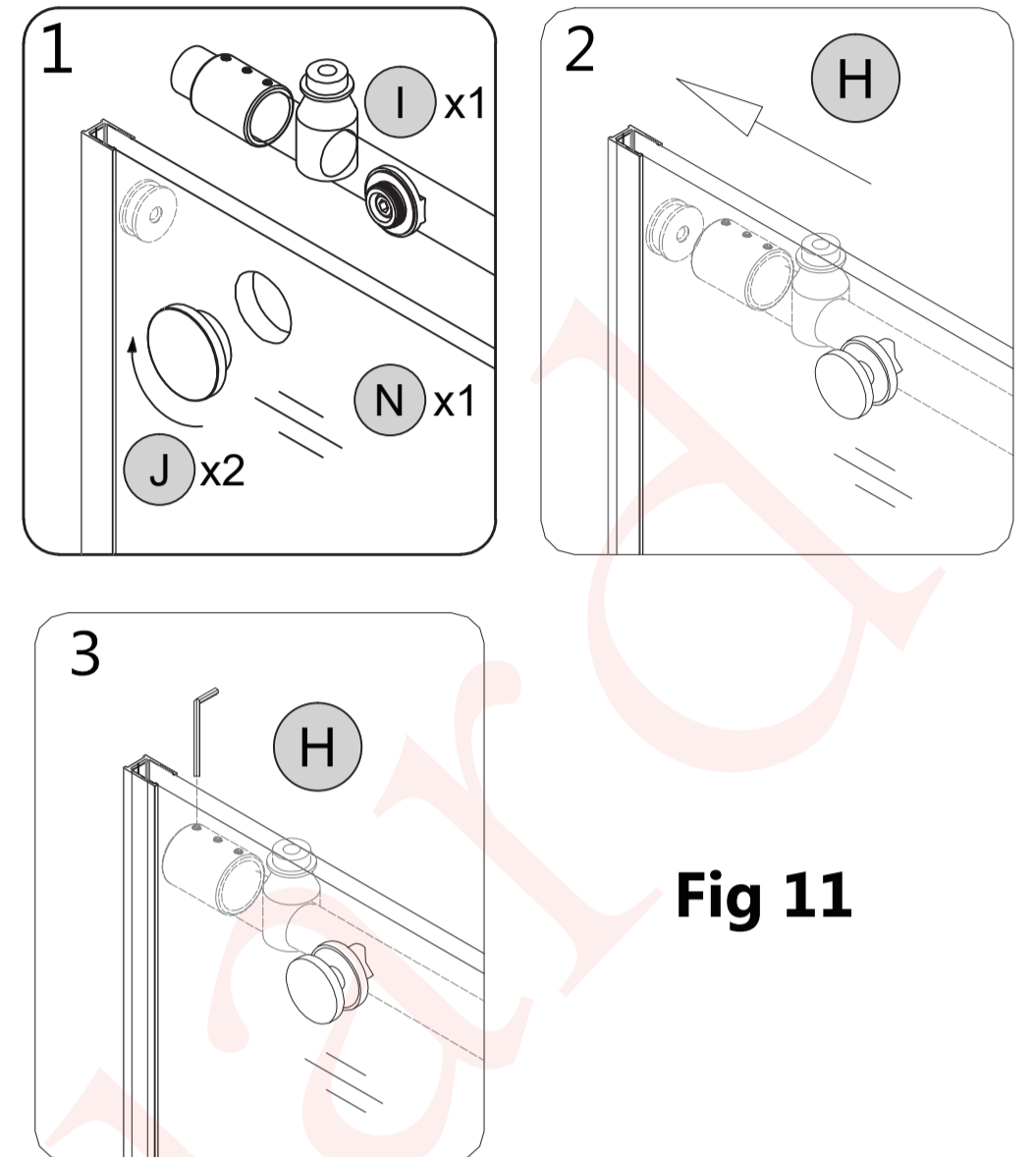


Fig 10

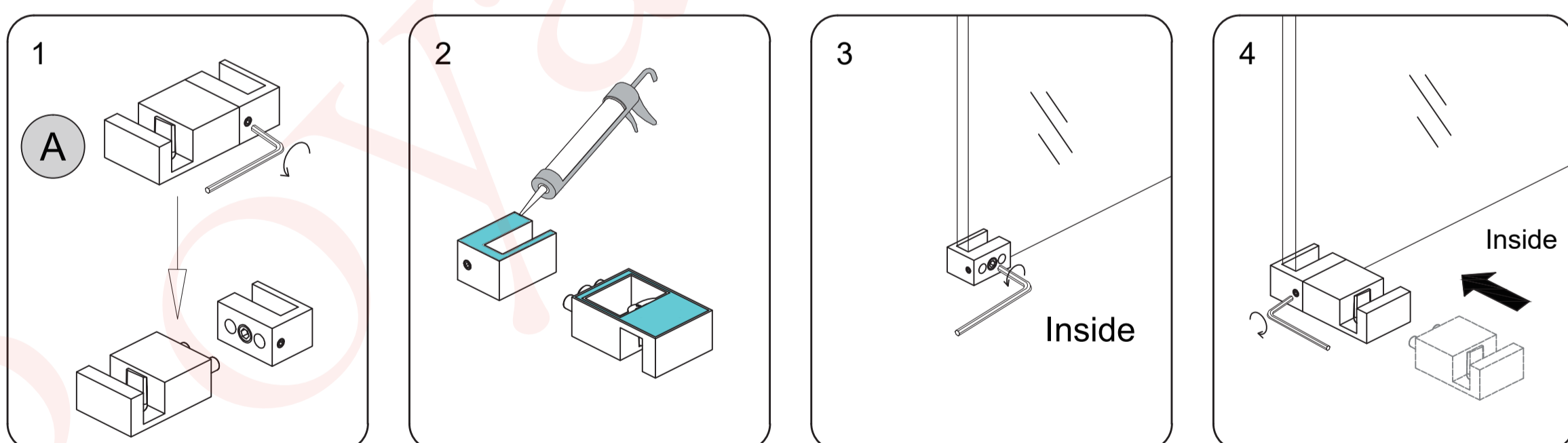
**CAUTION:** When cutting or drilling metal components or when handling glass, to reduce the risk of personal injury, protective eye wear, gloves, and closed-toe shoes are required.

- 11** Re-attach the **Guide Rail (I)** to the **Stationary Glass (N)** and attach the **Guide Rail Brackets (H)**. (Fig 11)



**Fig 11**

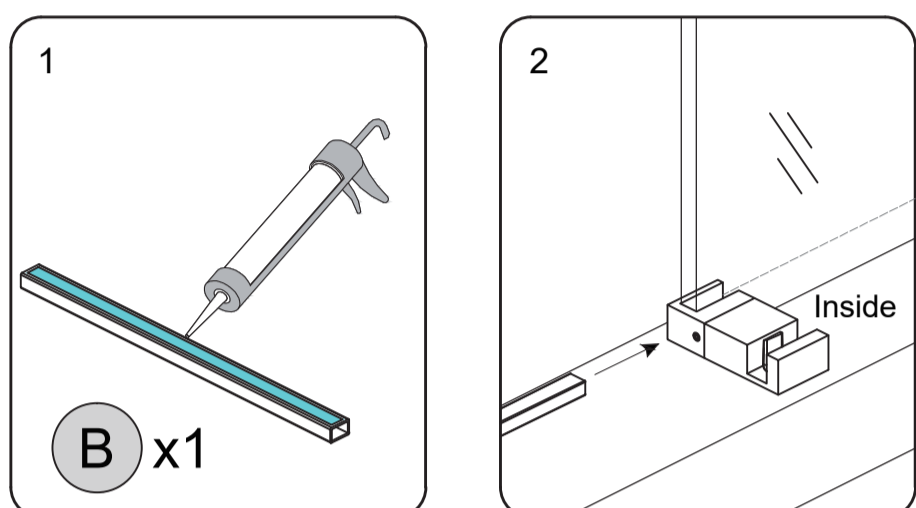
- 12**
1. Loosen the set screw and remove the guide block face plate. (Fig12.1)
  2. Apply silicone to the underside of the **Guide Block (A)**.(Fig 12.2)
  3. Fix the small part removed from **Guide Block (A)** on **Stationary Glass(N)**, and lock it with **Stationary Glass(N)** with a hexagonal key.Note that the side with screw hole faces into the shower room.(Fig 12.3)
  4. Install the remaining parts of **Guide Block (A)** and fix them with a hexagon key.(Fig 12.4)



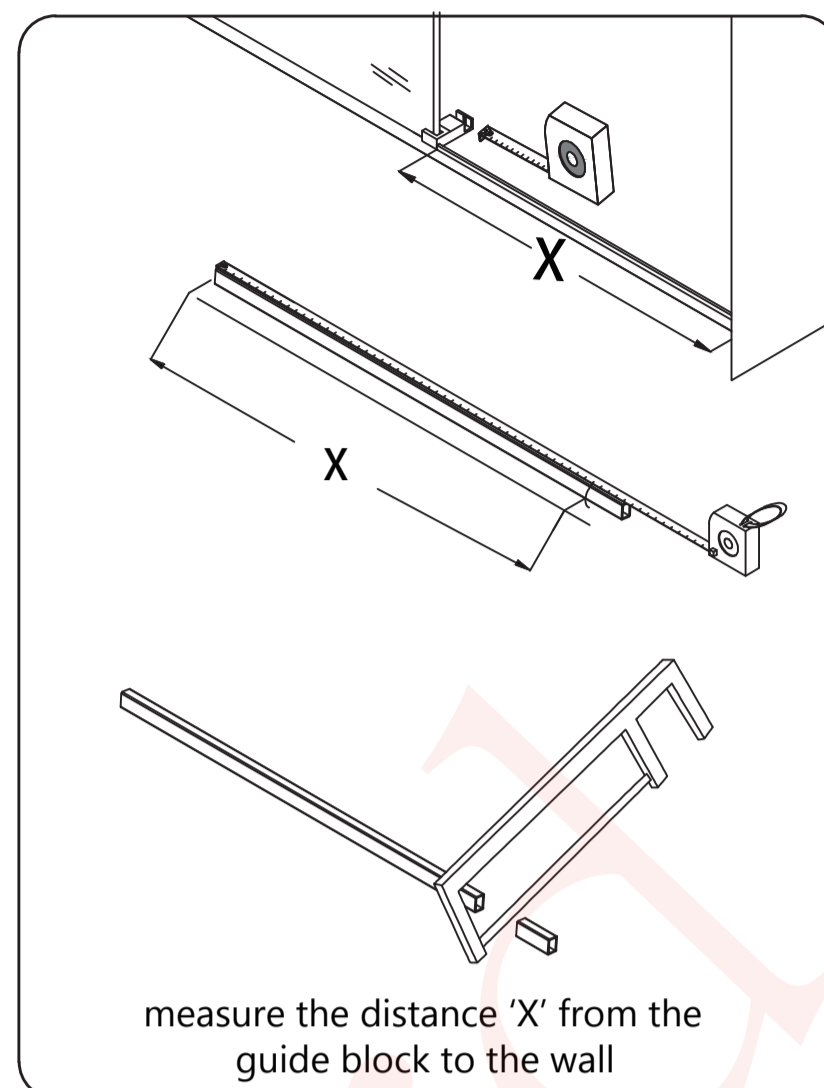
**Fig 12**

**13** Measure the distance from the edge of the **Guide Block (A)** to the wall. This distance will be "X". Cut the **Anti-Splash Guard (B)** to the size of: X. (**Fig 13**)

**14** Apply silicone to the bottom of the **Anti-Splash Guard (B)** (**Fig 14.1**). Keep **Anti-Splash Guard (B)** level with the water retaining strip or bottom basin. (**Fig 14.2**)



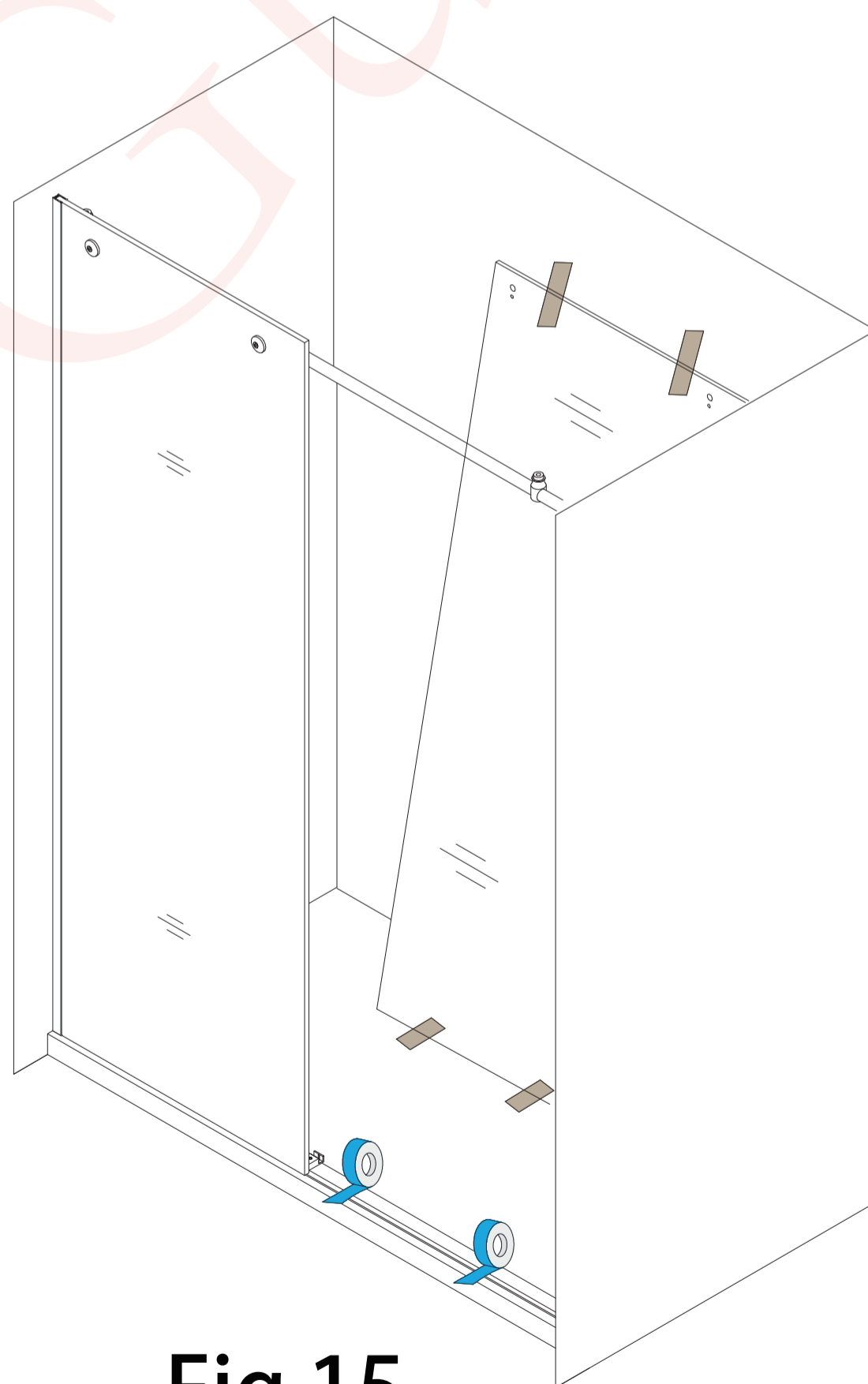
**Fig 14**



**Fig 13**

**15** Secure the **Anti-Splash Guard (B)** to the threshold with several pieces of painter's tape to hold it in position tight to the threshold until the silicone fully cures. (**Fig 15**)

**CAUTION:** When cutting or drilling metal components or when handling glass, to reduce the risk of personal injury, protective eye wear, gloves, and closed-toe shoes are required.



**Fig 15**

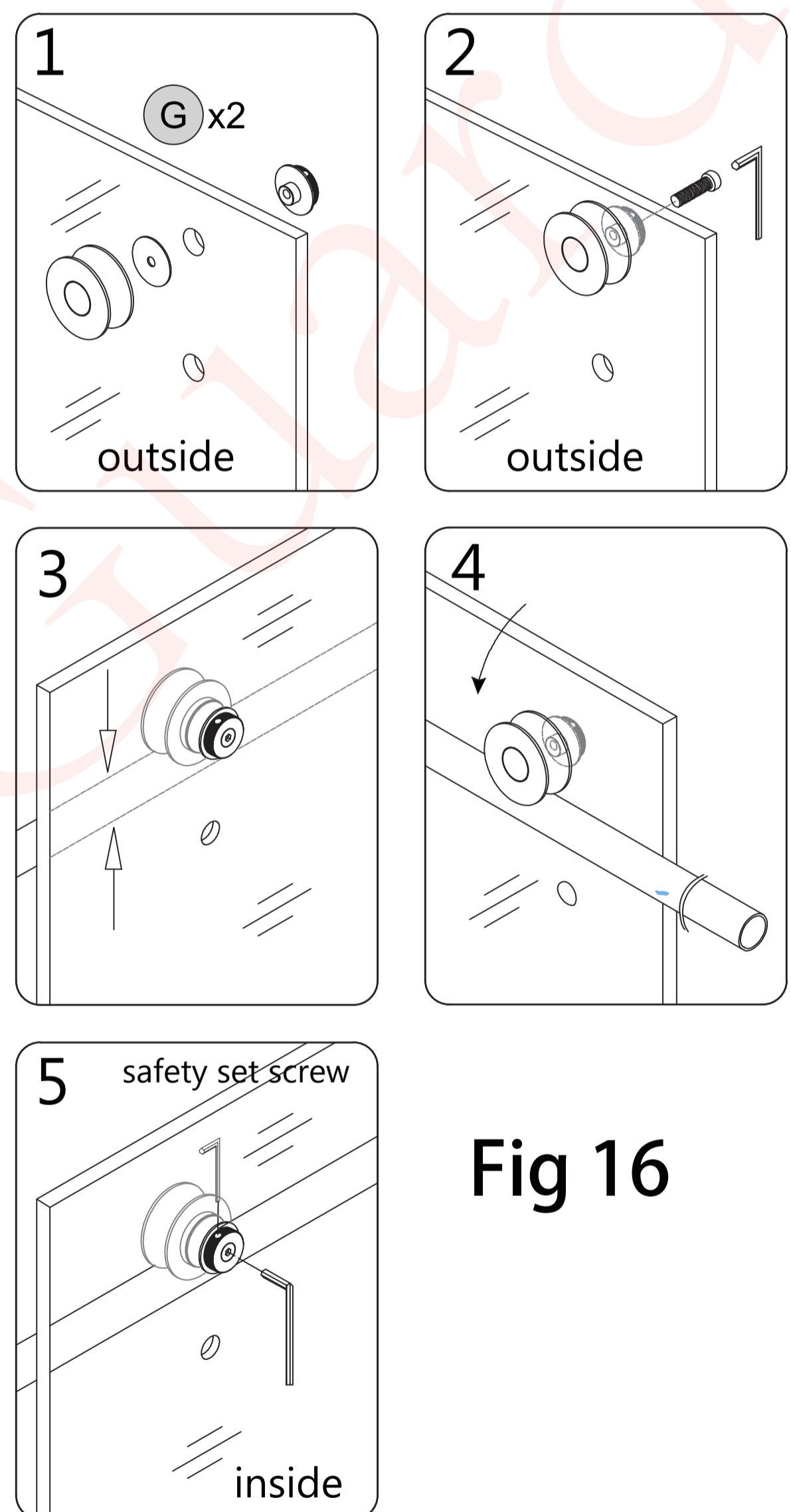
**NOTE: DO NOT** attach the handle to the door glass until instructed.  
**DO NOT** attempt to lift the door glass with the handle as this may result in damage to the glass and/or serious personal injury.

**16**

1. Loosen the lid and set screws, attach the two **Rollers (G)** to the **Door Glass (D)**. Note that the side with screw hole faces into the shower room. (Fig 16.1)
2. Tighten the screws with a hex key. The lid does not need to be installed, and the wheels need to be adjusted in the following steps (Fig 16.2 and Fig 16.3)
3. Lift the door and position the **Rollers (G)** onto the **Upper Guide Rail (I)** while carefully guiding the bottom edge of the **Door Glass (D)** into the groove of the **Guide Block (A)**. (Fig 16.4)
4. If necessary, adjust the disks on both **Rollers (G)** to ensure that the bottom edge of the **Door Glass (D)** does not touch the **Guide Block (A)**. (see details on page 22). (Fig 16.5)

Note: The adjustment disks can be rotated to adjust the door glass to create a seal with the wall. See detailed description on page 22.

**TIP:** Use a shim or padding at about 3/16" thickness beneath the door glass when adjusting the level of the door so that the glass does not make contact with the **Guide Block (A)**.



**Fig 16**

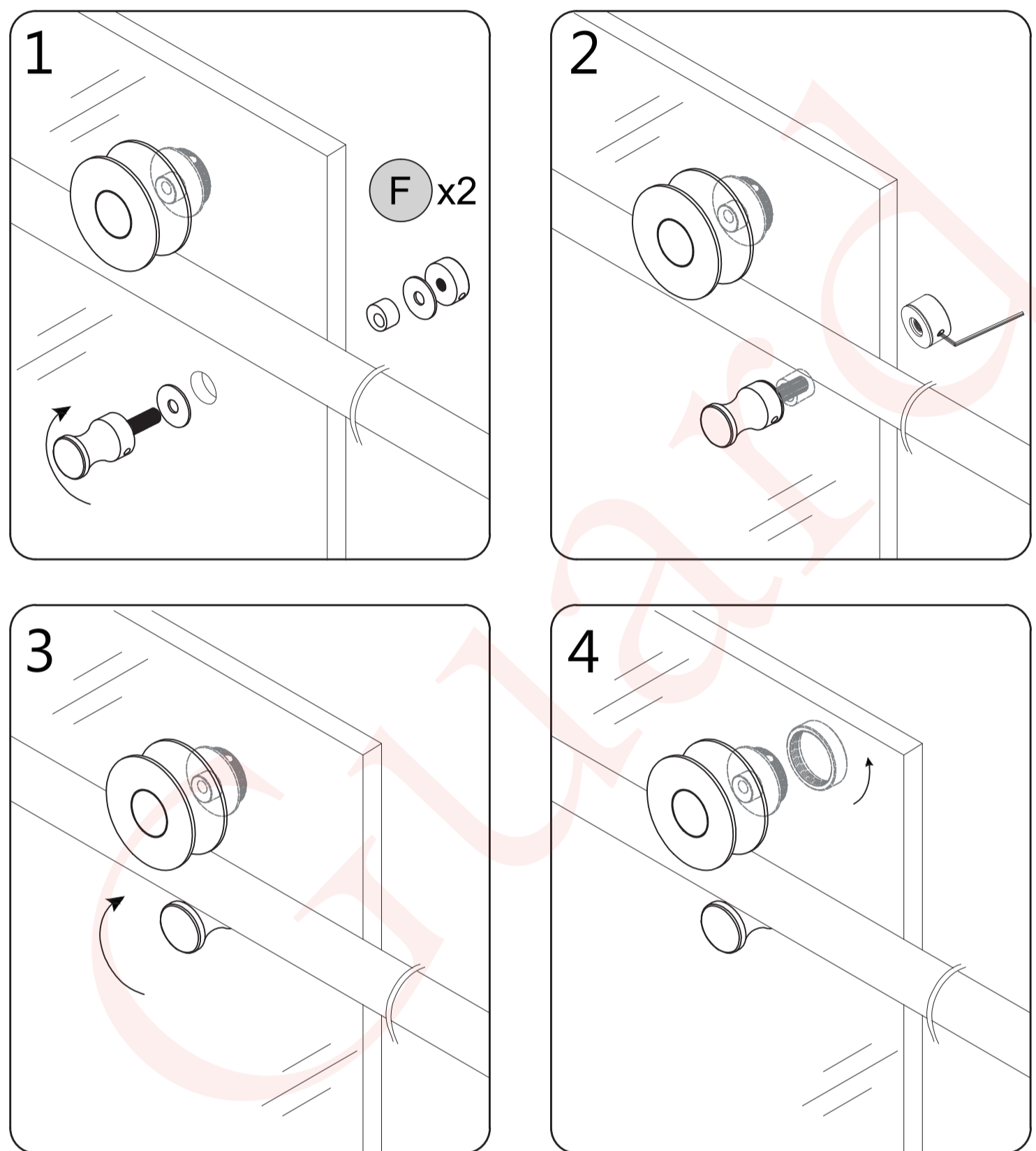
**CAUTION:** When cutting or drilling metal components or when handling glass, to reduce the risk of personal injury, protective eye wear, gloves, and closed-toe shoes are required.

**17**

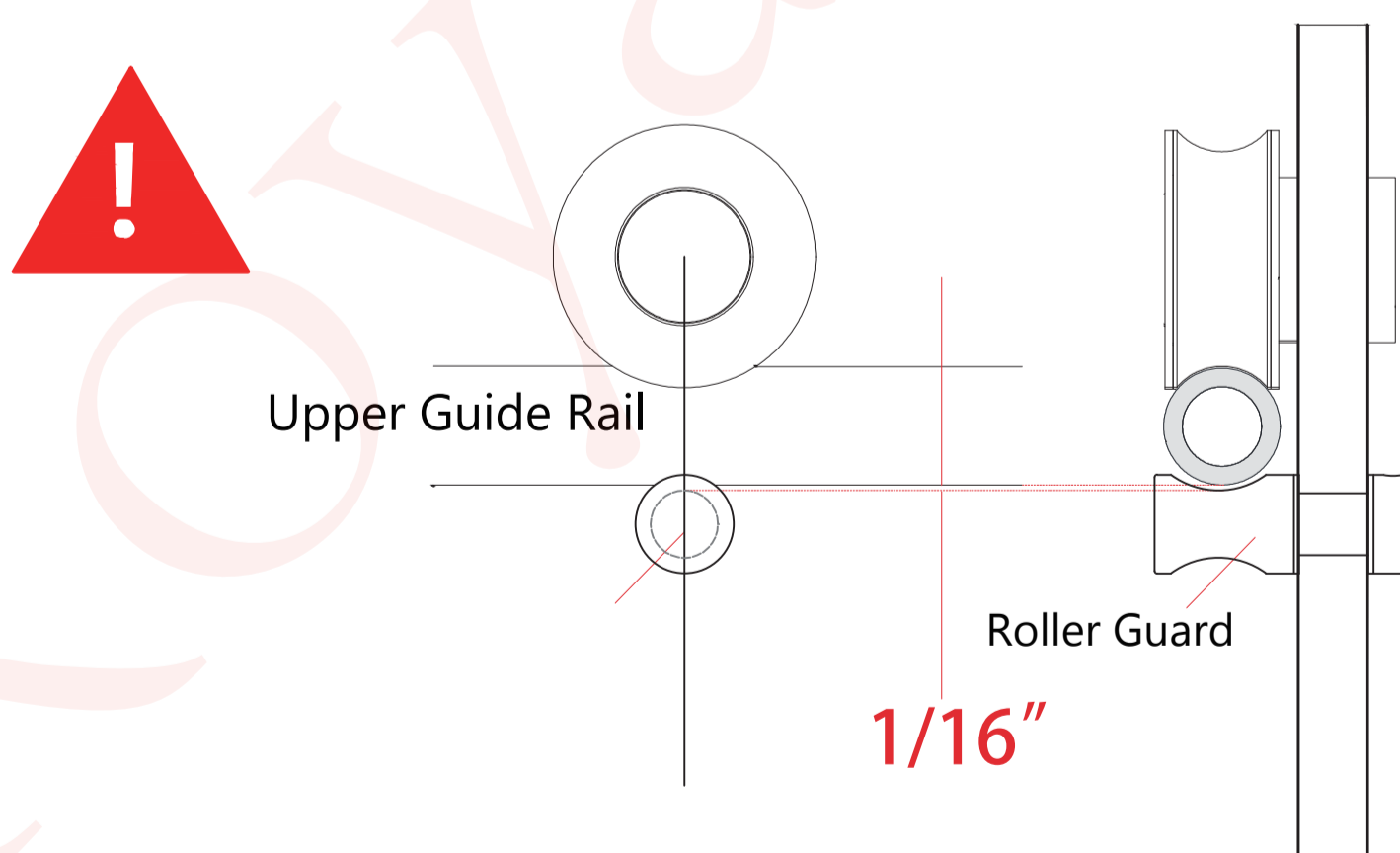
1. Attach the two **Roller Guards (F)** onto the door to secure the door to the **Upper Guide Rail (I)**. Screw **Roller Guards (F)** onto the glass by hand.(Fig 17.1)
2. Leave no more than a  $1/16''$  gap between the **Roller Guards (F)** and the **Upper Guide Rail (I)**. (Fig 17.2)
3. Lock **Roller Guards (F)** with the hexagonal key.(Fig 17.3 )
4. Tighten the bolt and screw on the cap. Close the cover of **Roller (G)**. (Fig 17.4)

**TIP:** Position the **Roller Guard(F)**  $1/16''$  below the rail, hold the **Roller Guard(F)** bolt with the Allen wrench and tighten the interior post using the small Allen wrench. (Fig 17.2)

**CAUTION:** When cutting or drilling metal components or when handling glass, to reduce the risk of personal injury, protective eye wear, gloves, and closed-toe shoes are required.

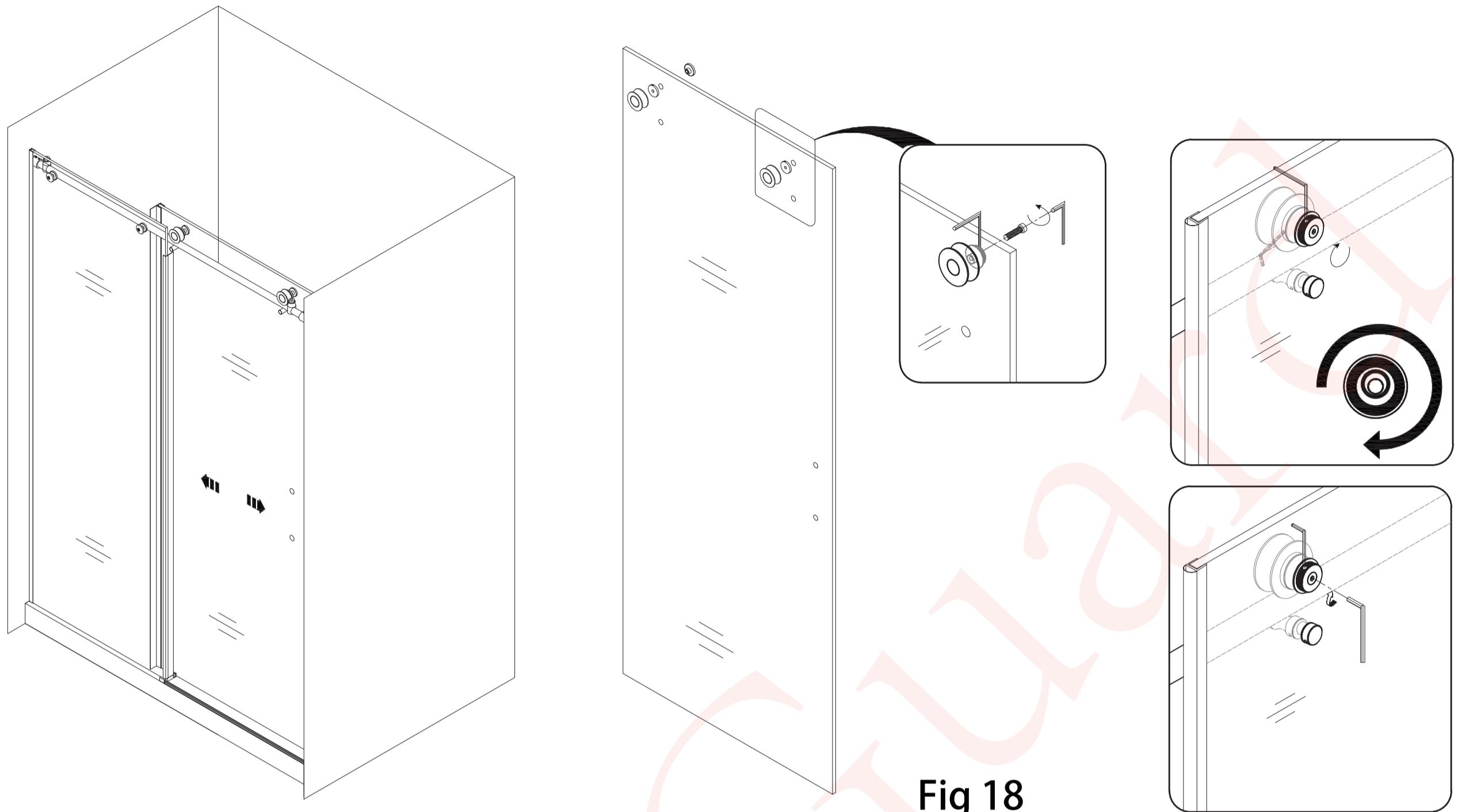


**Fig 17**



**CAUTION:** When cutting or drilling metal components or when handling glass, to reduce the risk of personal injury, protective eye wear, gloves, and closed-toe shoes are required.

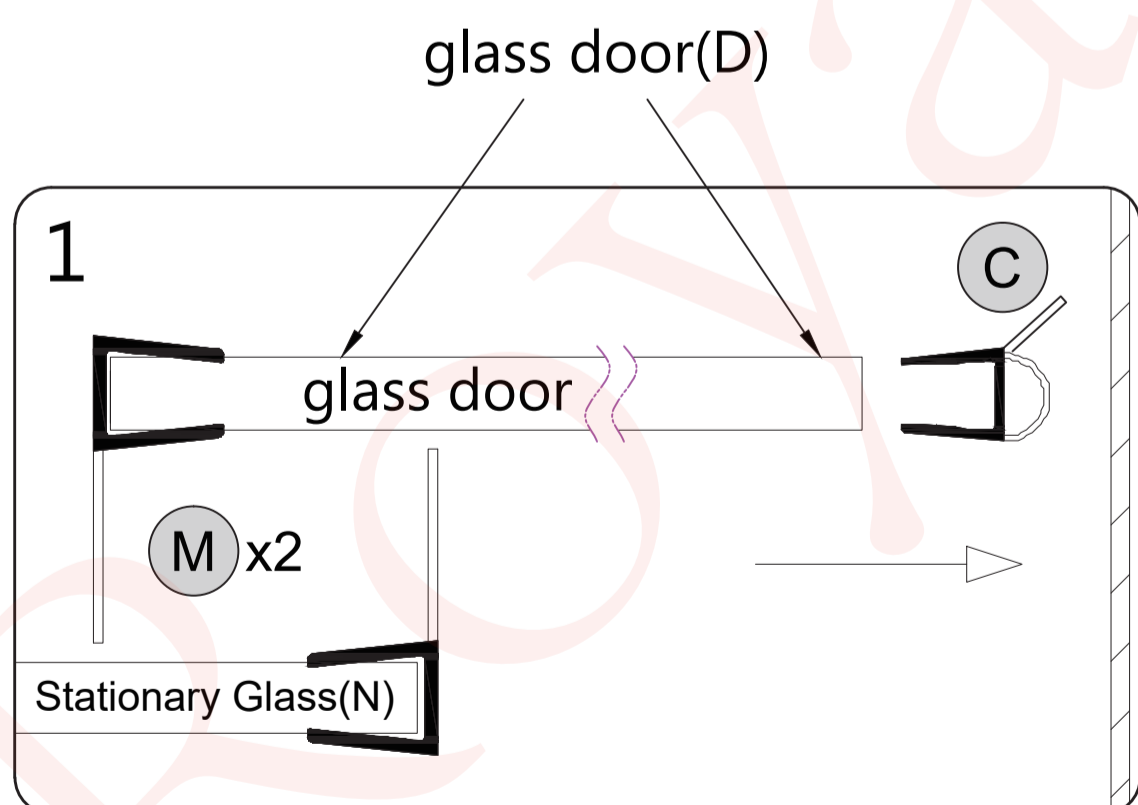
**Note:** The Safety set screw on both wheels **MUST BE RE-TIGHTENED after installation** to prevent the large bolt from coming loose. (Fig 18)



**Fig 18**

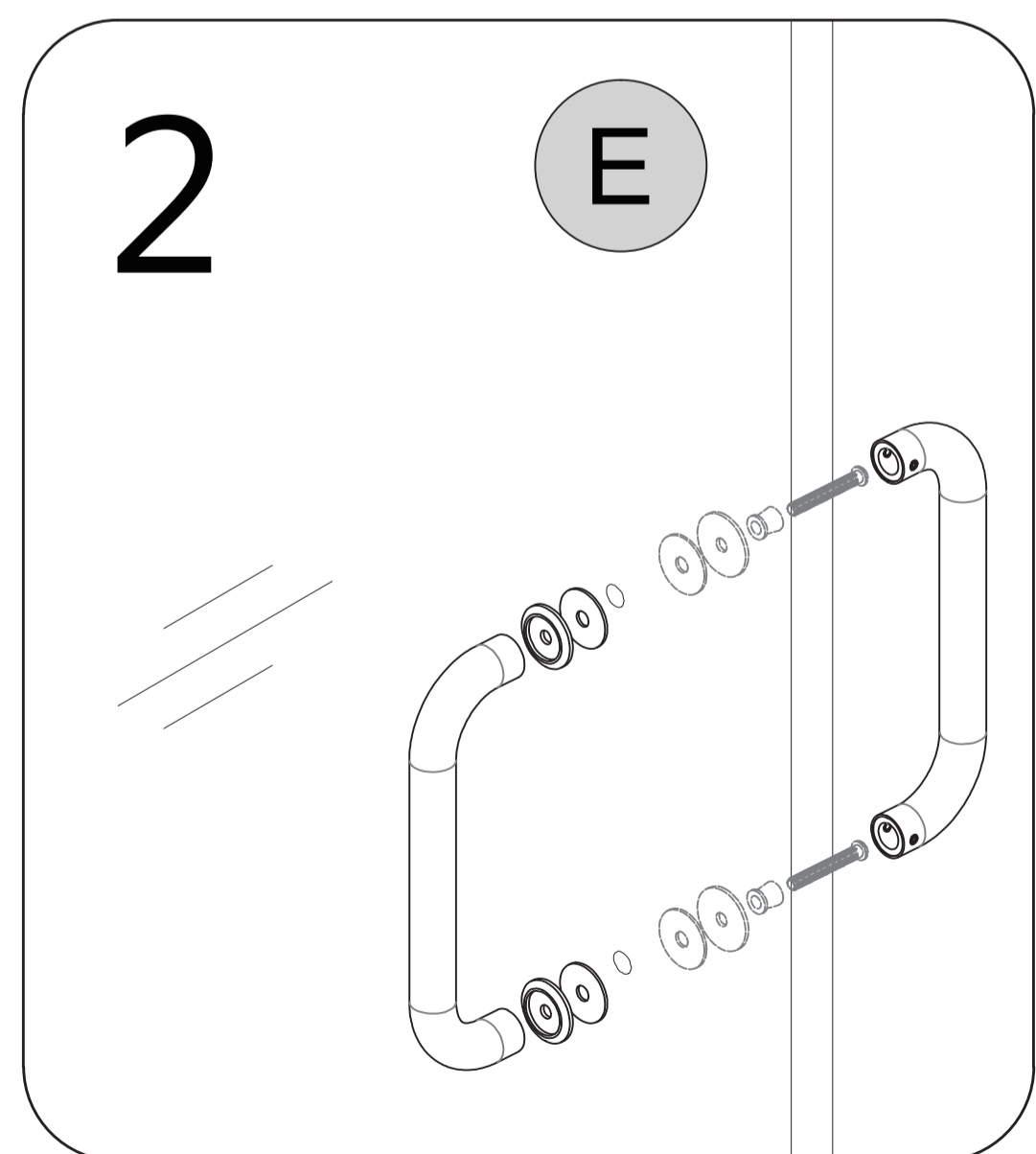
**18** Press the **Anti-Water Strip (M)** onto the vertical edge of the **Stationary Glass (N)** and the **Door Glass (D)**. Press the **Bumper Strip (C)** onto the vertical edge of the **Door Glass (D)**. (Fig 19.1)

Attach the **Handle (E)** to the **Door Glass (D)**. (Fig 19.2)



(Right hand door installation shown as an example)

**Fig 19**



**CAUTION:** When cutting or drilling metal components or when handling glass, to reduce the risk of personal injury, protective eye wear, gloves, and closed-toe shoes are required.

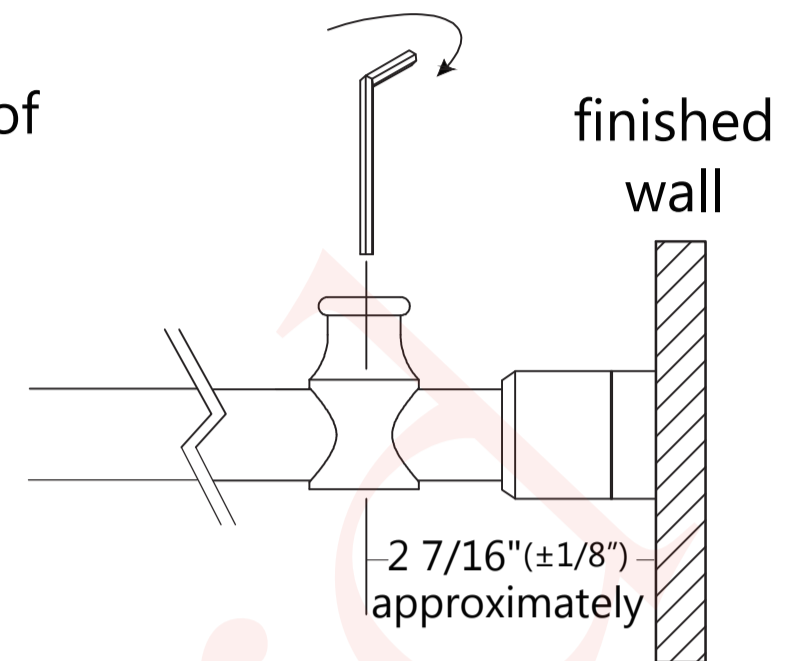


**19** The position can be adjusted by adjusting the tightness of the socket head cap screws on **Door Stoppers (K)** .

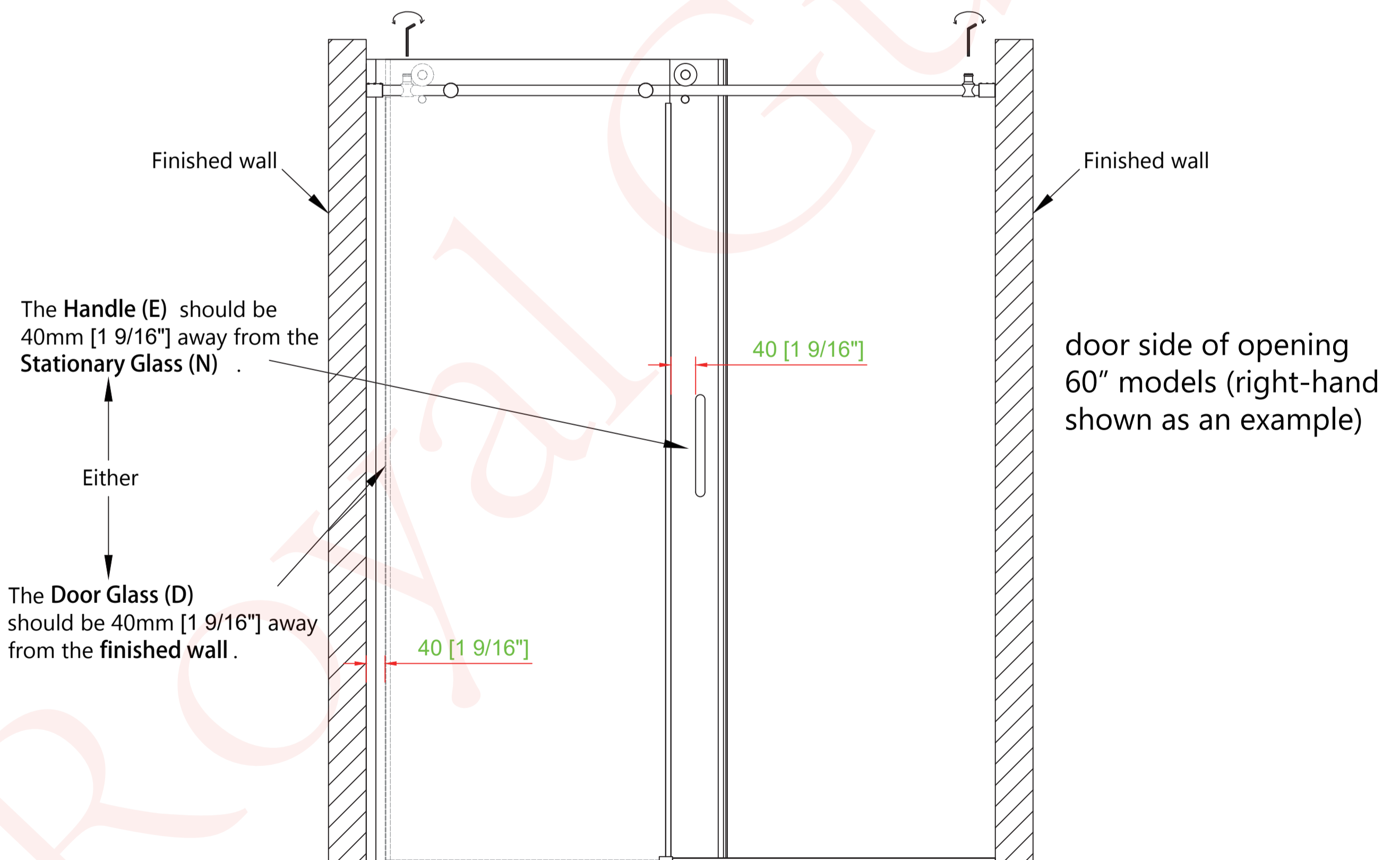
1、 On one side of **Door Glass (D)** , the center of **Door Stoppers (K)** is about  $[2 \frac{7}{16}]$  inches, from the finished wall. (Fig 20a)

2、 Loosen the screw on the left **Door Stoppers (K)** , Gently open the **Door Glass (D)** and adjust the **Handle(E)** to  $[1 \frac{9}{16}]$  inches from the edge of the **Stationary Glass (N)** or adjust the **Door Glass (D)** to  $[1 \frac{9}{16}]$  inches from the finished wall. Move the left **Door Stoppers (K)** to the roller and tighten the screw.(Fig 20b)

3、 After locking, open and close the **Door Glass (D)** gently to ensure that the **Door Glass (D)** can be sealed with the wall when closing the door, the **Door Glass (D)** will not hit the wall when opening the **Door Glass (D)** , and the handle will not touch the **Stationary Glass (N)** .



**Fig 20a**

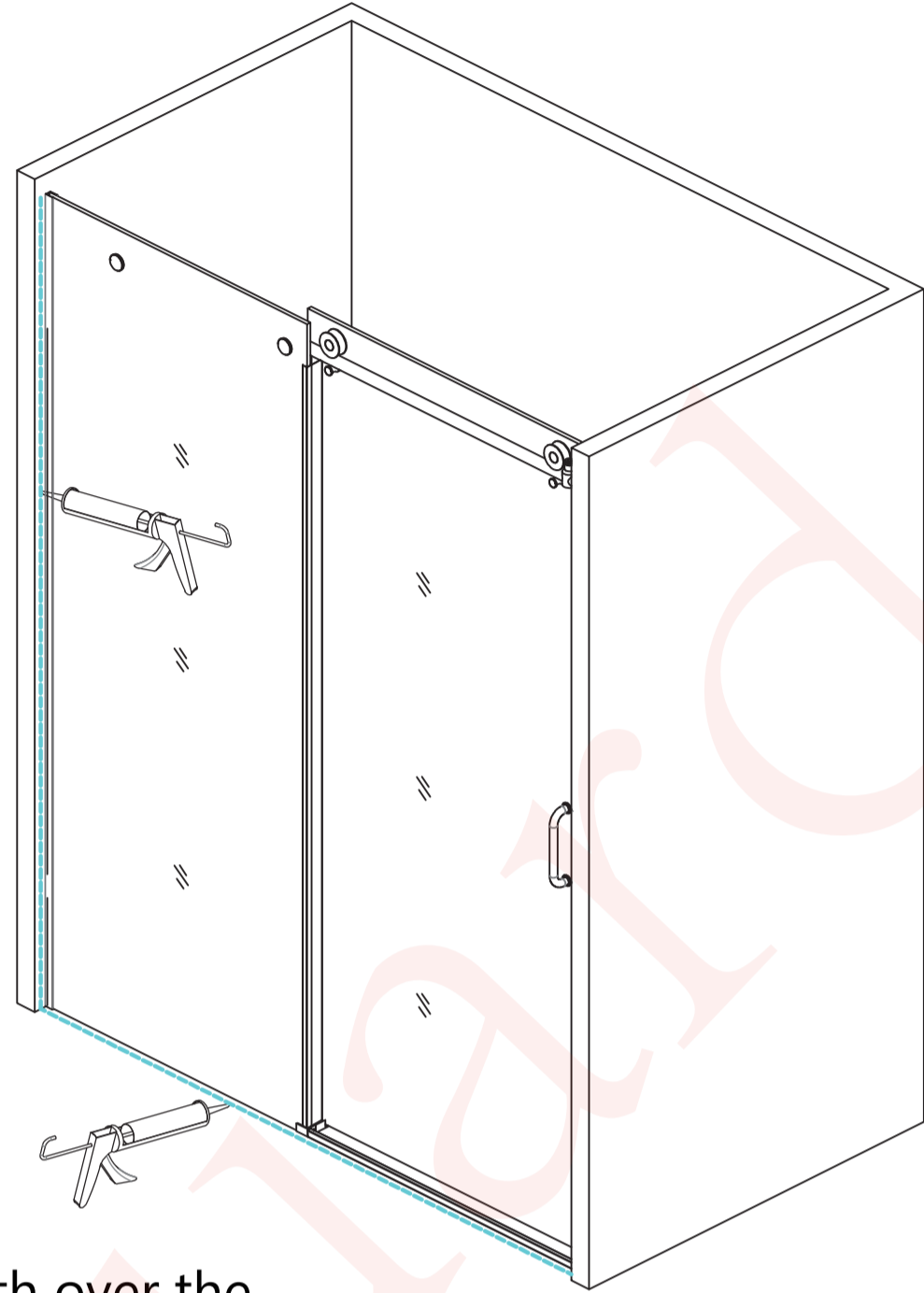


**Fig 20b**

**20** Ensure that the Shower door closes tightly and opens smoothly.  
Apply a good quality silicone sealant along the Fixed panel  
Allow 24 hours for silicone to dry before use.

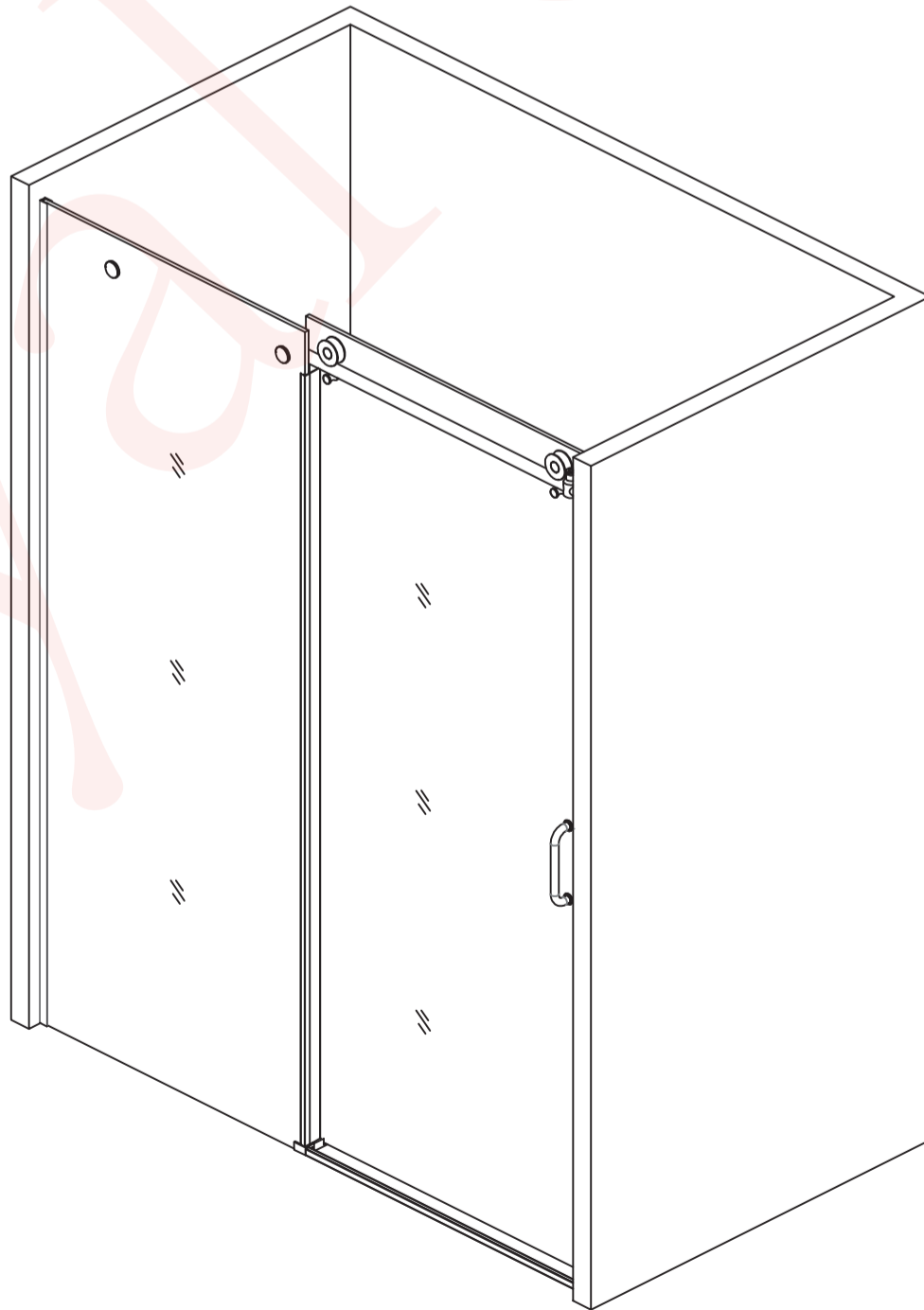


**!** Apply Silicone Sealant, (not supplied).



Do not hang or drape a towel or wash cloth over the guide rail as this may cause the roller wheels to get stuck and possibly cause serious damage or injury.

**21** Complete.



## Roller adjustment procedure

To achieve minimal clearance beneath the door glass without making contact with the bottom guide block and creating a good seal with the wall.

Have at least two 3/16" shims or wedge shims (to maintain space beneath the door glass) and an assistant available to help with this procedure.

You should adjust only one wheel at a time and you may need to perform these steps more than once to get the desired results.

**Caution: The door glass is heavy and may require two people to safely accomplish these steps.**

1. First, loosen and lower either the Roller Guards or to allow you enough room to adjust the upper rollers.
2. Loosen the decorative cover on the roller. (See note 2 below)
3. Loosen the big bolt just enough so that you can rotate the adjustment disk. (See note 3 below)
4. Rotate the adjustment disk to raise or lower the door slightly with help from an assistant. You can use a small tool (like an allen wrench) to aid in turning this disk by inserting it into the small hole on the edge of the adjustment disk. (see note 4 & 5 below)
5. While holding the adjustment disk in place, retighten the big bolt. Use a shim or have an assistant hold the door glass in place while you retighten the big bolt. Test the operation of the door.
6. Reposition the roller guards approximately 1/16" beneath the guide rail and retighten.

