

1

Align the groove of C parts with the welding groove of A parts, insert it, and then screw it on

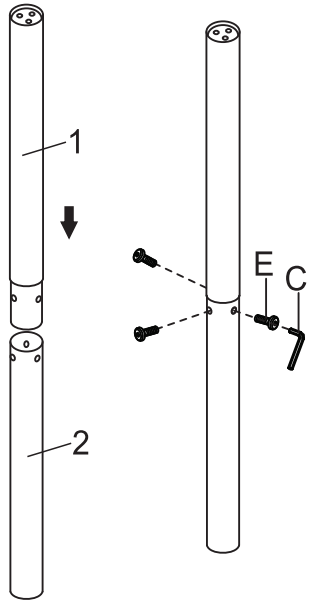

2

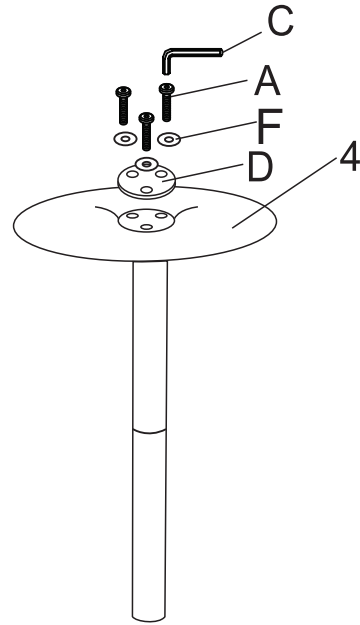

3

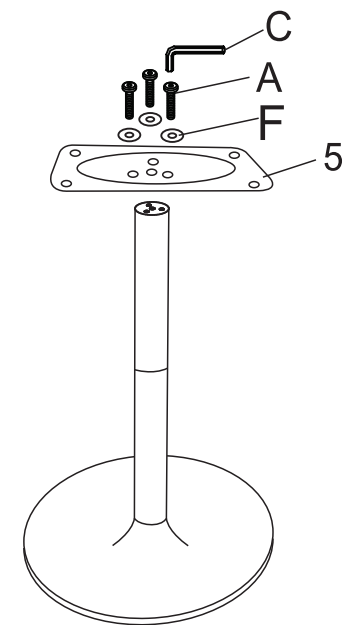



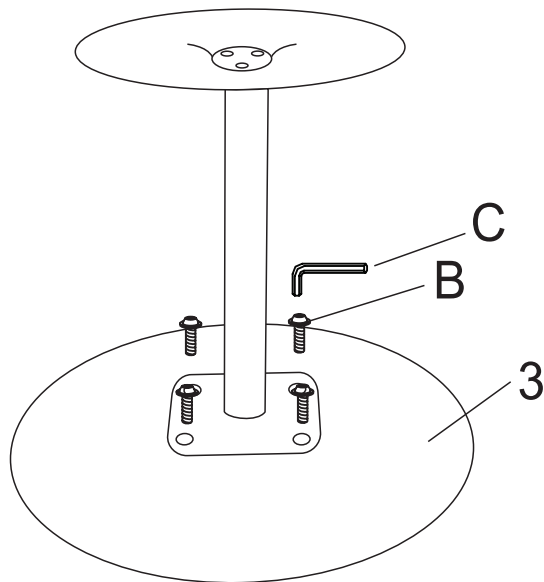



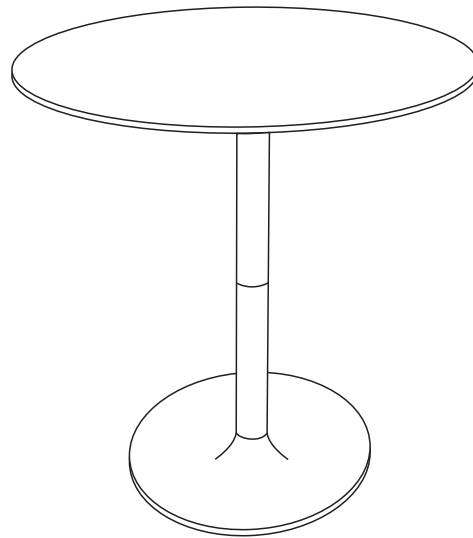

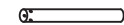

4



5

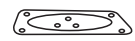

①		1	B	 M6x14mm	4
②		1	C		1
③		1	D		1
④		1	E	 M6x13mm	3
⑤		1	F	 M8	6
A	 M8x40mm	6			